

No. 657,636.

Patented Sept. 11, 1900.

G. W. BINGHAM.
CAN.

(Application filed Dec. 8, 1899.)

(No Model.)

2 Sheets—Sheet 1.

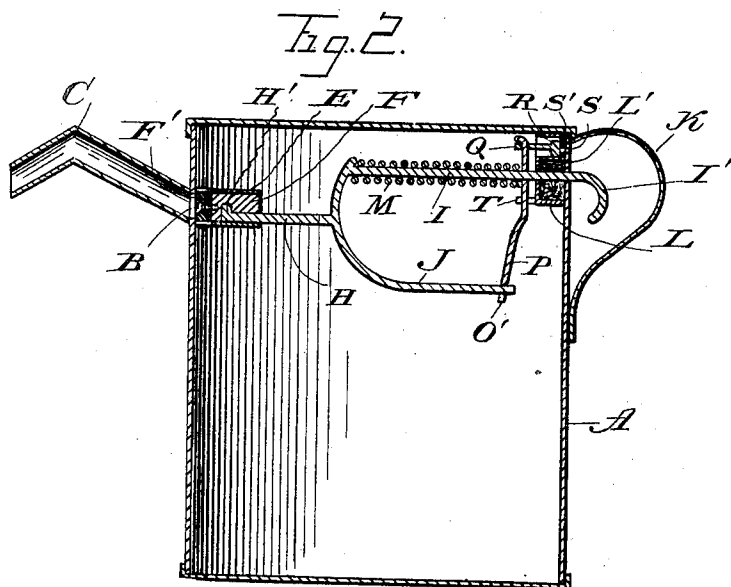
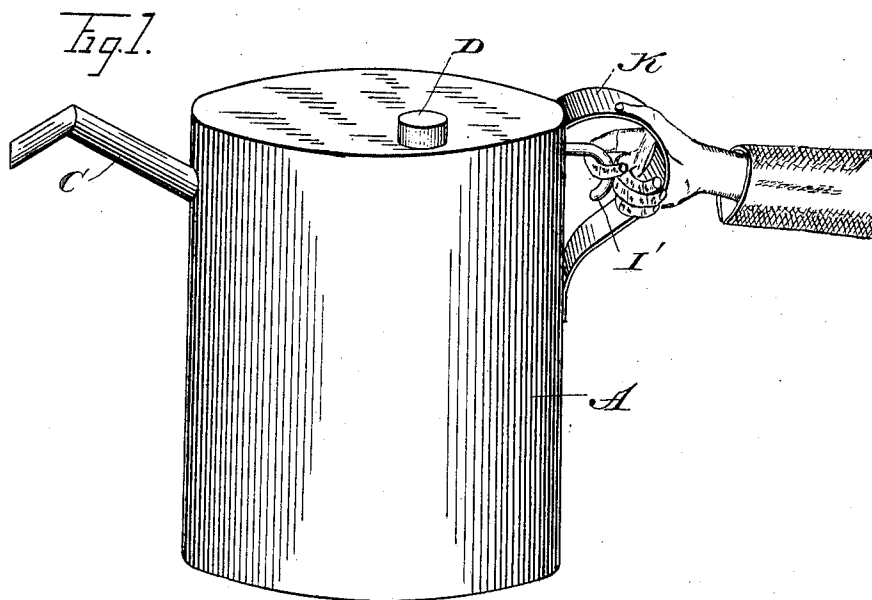

WITNESSES:

E. A. Ryan.

James W. Deane

INVENTOR

Gourdy W. Bingham

BY

Frank M. Church

ATTORNEY.

G. W. BINGHAM.
CAN.

(Application filed Dec. 6, 1899.)

(No Model.)

2 Sheets—Sheet 2.

Fig. 3.

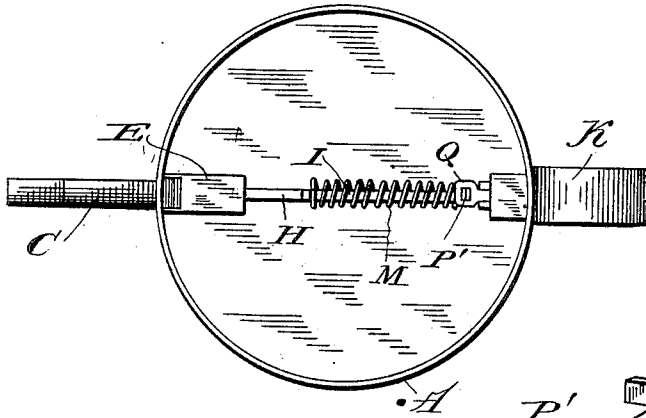

Fig. 4.

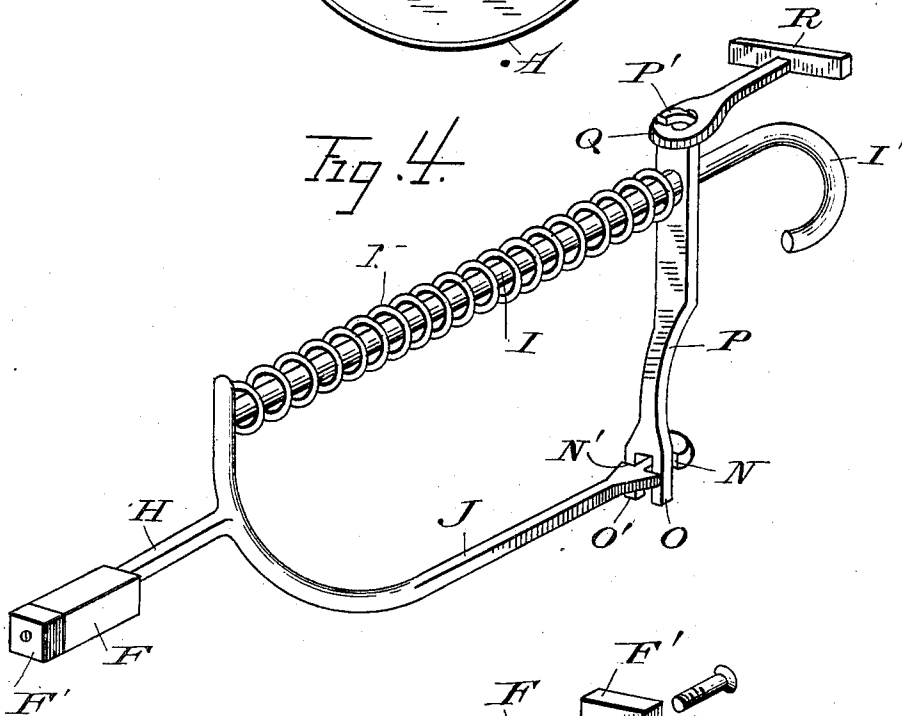
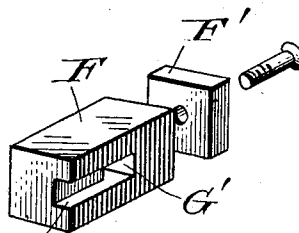

Fig. 5.



WITNESSES.
E. A. Ryan
James W. Berans

INVENTOR.
G. Goundry St. Bingham
 BY.
Frank M. Church
 ATTORNEY.

UNITED STATES PATENT OFFICE.

GOUNDRY W. BINGHAM, OF WASHINGTON, DISTRICT OF COLUMBIA.

CAN.

SPECIFICATION forming part of Letters Patent No. 657,636, dated September 11, 1900.

Application filed December 6, 1899. Serial No. 739,390. (No model.)

To all whom it may concern:

Be it known that I, GOUNDRY W. BINGHAM, a citizen of the United States, residing at Washington, in the District of Columbia, have
5 invented certain new and useful Improvements in Cans; and I do hereby declare the following to be a full, clear, and exact description of the invention, such as will enable others skilled in the art to which it apper-
10 tains to make and use the same.

This invention relates to improvements in cans for storing, transporting, and dispensing fluids; and the object is to provide a can from
15 which the fluid cannot spill or leak and which may be conveniently and readily operated to open the outlet and vent when it is desired to remove the contents.

The invention consists in the novel features of construction which are set forth in the
20 following specification, particularly pointed out in the claims, and fully illustrated by the accompanying drawings, in which—

Figure 1 is a perspective view of my improved can. Fig. 2 is a vertical sectional view
25 of the same. Fig. 3 is a top plan view. Fig. 4 is an enlarged perspective view of the mechanism for operating the valves for controlling the outlet and vent. Fig. 5 is a similar view
30 of the valve for controlling the outlet.

Referring now more particularly to the accompanying drawings, A designates the body of the can, provided with the outlet B, having
35 the spout C, and a filling-opening covered by the removable cap D. Secured upon the interior of the can in line with the outlet is the valve-casing E, receiving the endwise-mov-
40 able valve F. This valve has a flexible or elastic strip F' secured to its engaging end, so as to fit snugly against the valve-seat and
45 prevent the fluid leaking through the outlet when the valve is seated. Said valve is formed in its bottom wall with a longitudinally-extending groove G, receiving the valve-stem
H, said groove being formed at its inner end
50 with an offset G', in which a lug H' on the end of the valve-stem fits, so that the valve is removably secured to the stem. The valve-stem is formed with the rearwardly-extending parallel arms I and J, arm I extending
through the wall of the can and formed with a hooked end I', located contiguous to the

handle K of the can, to be engaged by the hand of the operator to unseat the valve. Said operating-arm I passes through a stuffing-box L, secured upon the interior of the
55 can and containing suitable packing L', so as to prevent leaking of the fluid from the can at that point. A spring M, coiled about the arm I, holds the valve to its seat and returns the same thereto when the arm is released.
60 The free end of arm J is slotted in its side edges, as at N N', to receive the bifurcations O O' of the lower end of a vertically-extending lever P, which lever is formed with an opening adjacent to its upper end through
65 which the operating-arm I loosely passes. It will be seen that through the medium of the connection between said lever and arm J the former may be readily connected with or disconnected from the latter. It will be seen
70 also that the spring coiled about arm I bears against the front face of said lever and acts to force the same rearwardly. The upper end of said lever is hooked, as at P', which hook engages an opening formed in the stem Q of
75 the vent-valve R. This valve R moves in a casing formed above the stuffing-box for arm I and controls the vent S. A flexible packing-strip S' is secured in said valve casing about said vent-opening, so that the valve
80 seats snugly thereagainst and leaking of fluid through the vent is prevented. The spring before mentioned bearing against the lever holds said vent-valve to its seat. Said lever is held from lateral movement by the guides
85 T, projecting from the lower end of the stuffing-box and engaging the lever intermediate its ends.

When it is desired to remove the contents of the can or any portion thereof, the arm I
90 is drawn upon, which unseats both valves. As soon as arm I is released both valves are returned to their seats by the action of the spring.

It will be understood that many slight
95 changes and modifications might be made in the construction shown and described without departing from the spirit and scope of my invention.

Having thus fully described my invention,
100 what I claim, and desire to secure by Letters Patent of the United States, is—

1. The combination with a can provided with outlet and vent openings, of a valve controlling the outlet-opening, and having a longitudinally-extending stem, a valve controlling the vent-opening, and a vertically-disposed lever connected at its respective ends with the stem of the outlet-valve and the vent-valve, substantially as described.

2. The combination with a can provided with an outlet and a vent opening formed in opposite walls of the body thereof, of inwardly-movable valves controlling said openings, and a vertically-disposed lever connected at its respective ends with the stems of said valves, substantially as described.

3. The combination with a can formed with an outlet and a vent opening, valves controlling said openings and movable transversely of the can-body, and a vertically-disposed lever connected at its respective ends to said valves, substantially as described.

4. The combination with a can provided with outlet and vent openings, of a valve controlling said outlet-opening, longitudinally-extending arms carried by said valve, one of said arms projecting to the exterior of the can-body, a valve controlling the vent, and an operative connection between the other of

said arms and the vent-valve, substantially as described. 30

5. The combination with a can provided with outlet and vent openings, of a valve controlling said outlet and having a bifurcated valve-stem; one of said bifurcations extending to the exterior of the can-body, a valve controlling the vent, and a lever connected at its respective ends with the vent-valve and other bifurcation of the outlet-valve stem, substantially as described. 35

6. The combination with a can provided with outlet and vent openings, of valves controlling said openings, a bifurcated valve-stem for said outlet-valve, one of said bifurcations extending to the exterior of the can-body, a lever loosely engaging said bifurcation and connected at its respective ends with the vent-valve and other of said bifurcations, and a spring holding said valves to their seats, substantially as described. 40 45

In testimony whereof I affix my signature 50 in presence of two witnesses.

GOUNDRY W. BINGHAM.

Witnesses:

JAMES W. BEVANS,
HOWARD C. RILEY.