

No. 667,455.

Patented Feb. 5, 1901.

E. PRESCOTT.
CENTRIFUGAL RAILWAY.

(Application filed Oct. 23, 1900.)

(No Model.)

3 Sheets—Sheet 1.

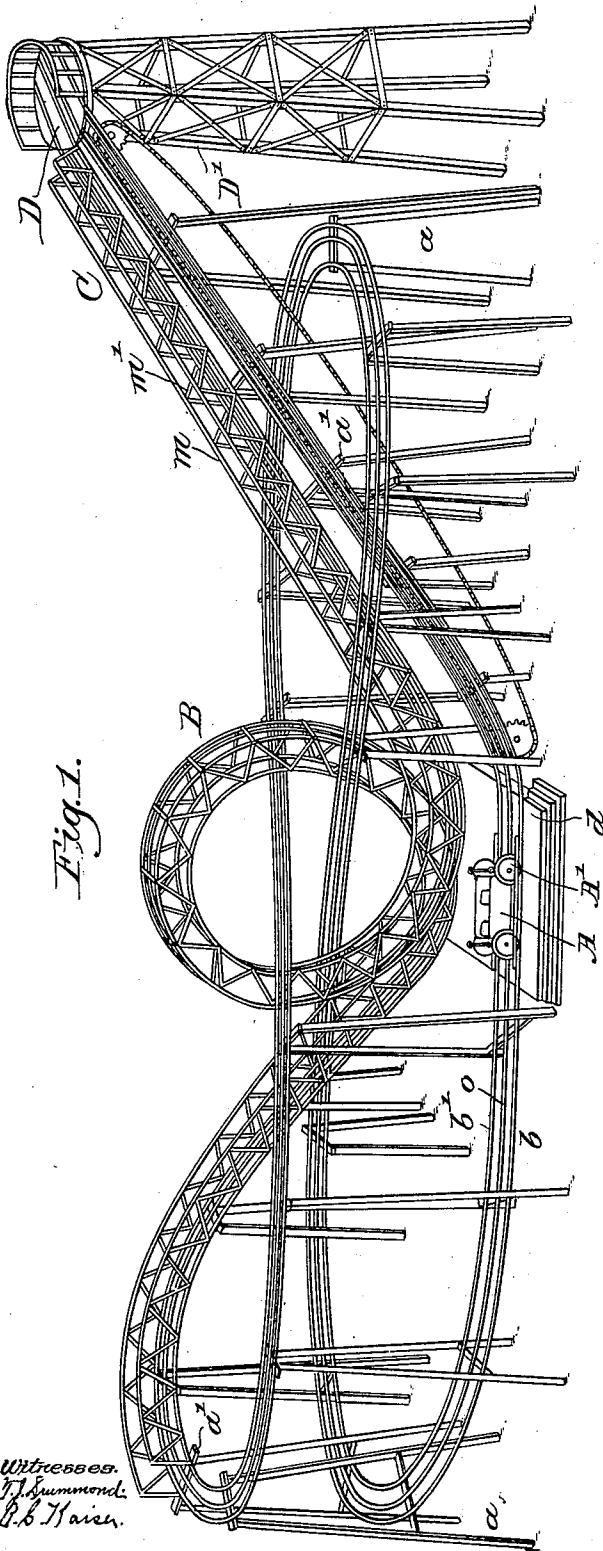

Fig. 1.

Witnesses.
T. J. Hammond.
R. B. H. H. H.

Fig. 3.

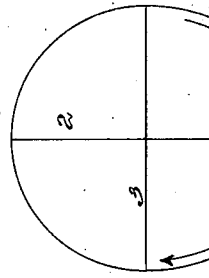
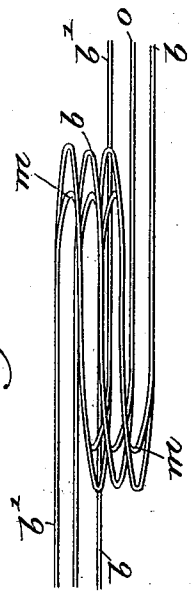

Fig. 2.



Inventor.
Edwin Prescott,
by Crosby & Mason,
Attys.

No. 667,455.

Patented Feb. 5, 1901.

E. PRESCOTT.
CENTRIFUGAL RAILWAY.

(Application filed Oct. 23, 1900.)

(No Model.)

3 Sheets—Sheet 2.

Fig. 4.

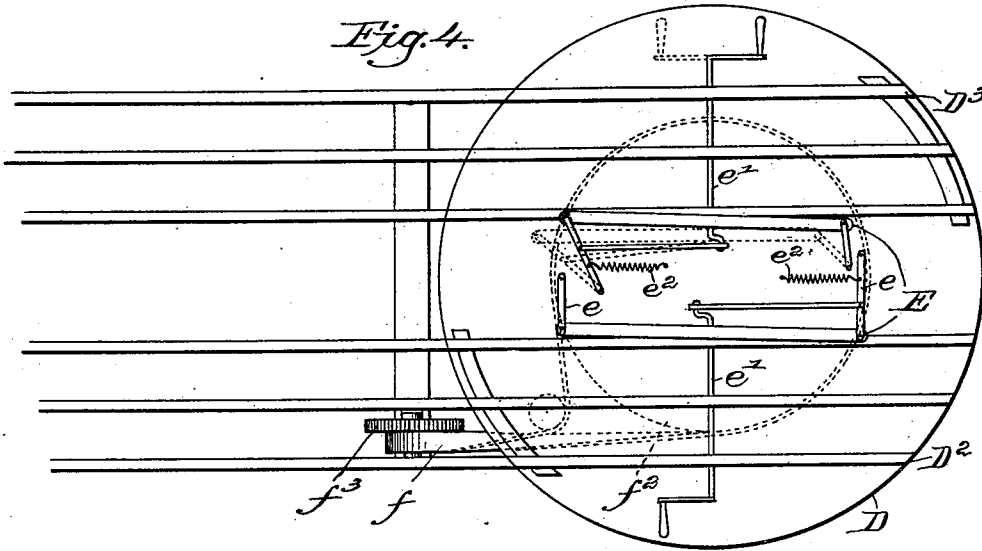
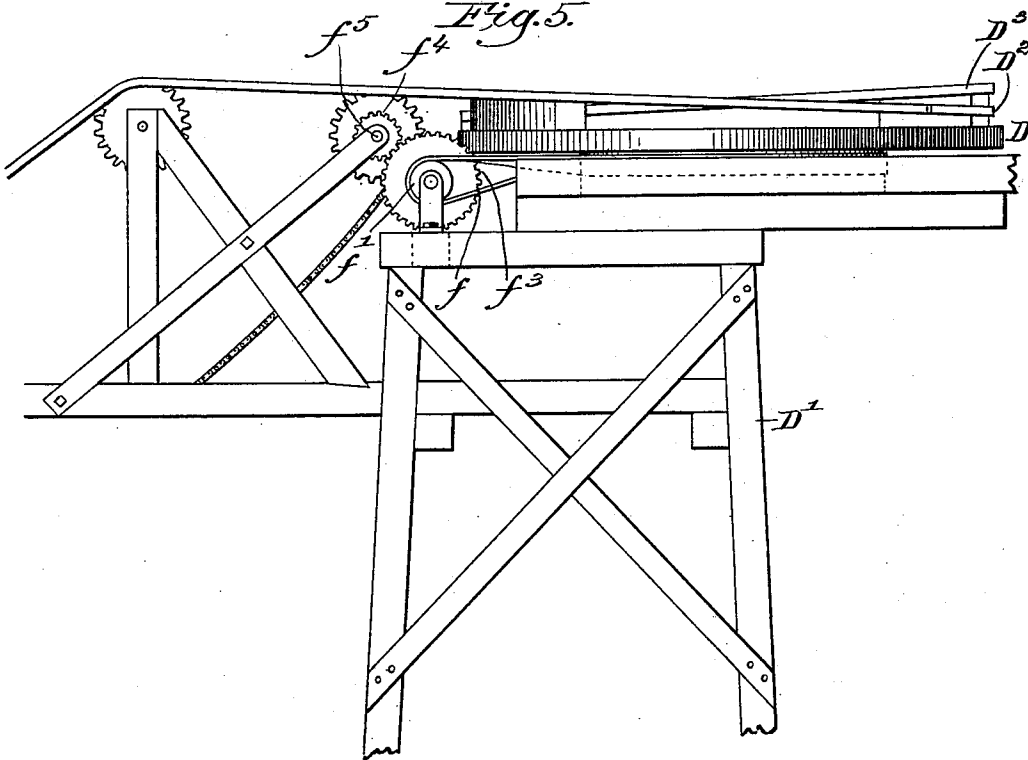

Fig. 5.



Witnesses.

Thomas J. Drummond.
Adolf C. Haizer.

Inventor.
Edwin Prescott,
by Massey Ferguson,
attys.

No. 667,455.

Patented Feb. 5, 1901.

E. PRESCOTT.
CENTRIFUGAL RAILWAY.

(Application filed Oct. 23, 1900.)

(No Model.)

3 Sheets—Sheet 3.

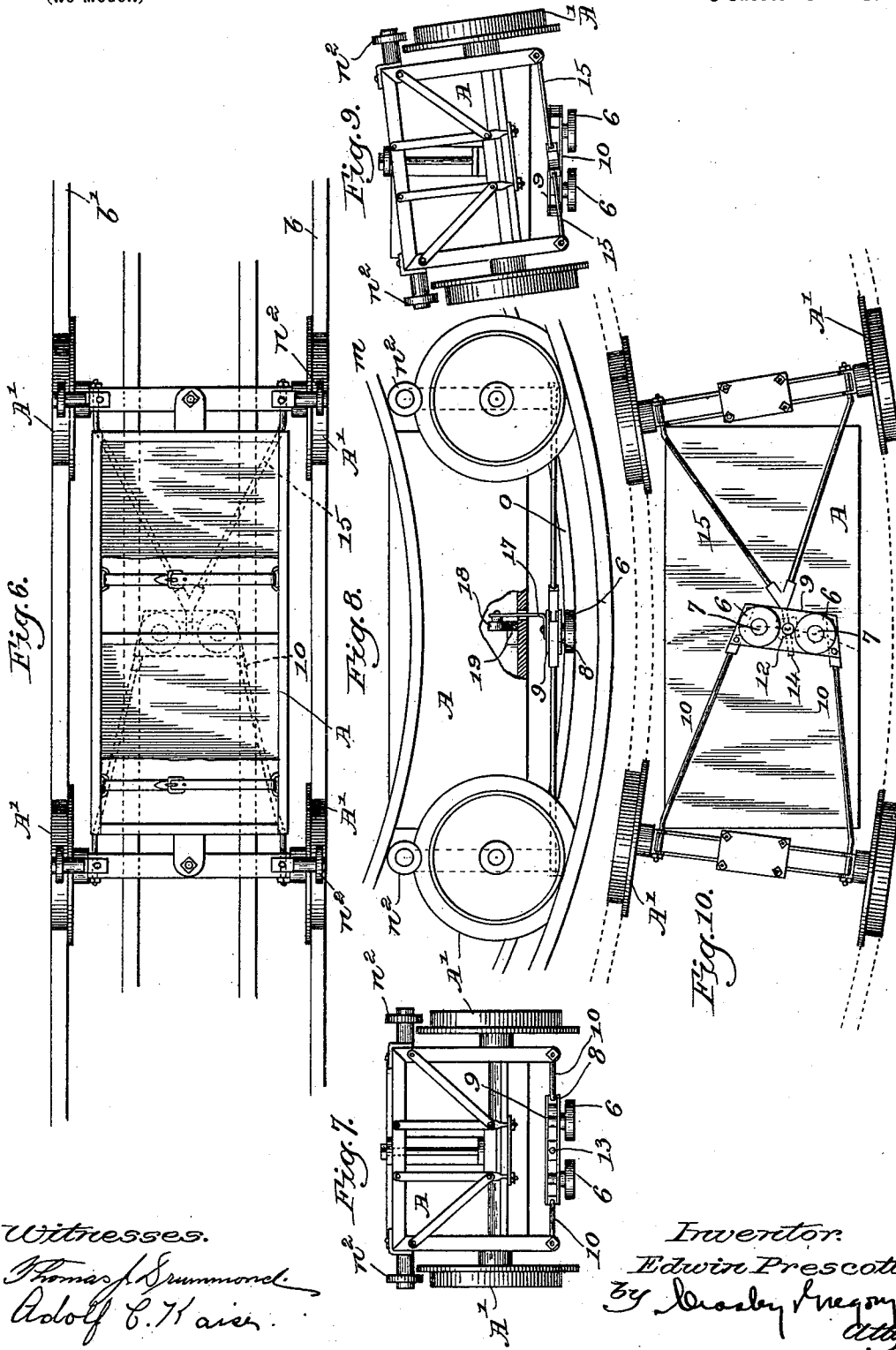

UNITED STATES PATENT OFFICE.

EDWIN PRESCOTT, OF ARLINGTON, MASSACHUSETTS.

CENTRIFUGAL RAILWAY.

SPECIFICATION forming part of Letters Patent No. 667,455, dated February 5, 1901.

Application filed October 23, 1900. Serial No. 34,068. (No model.)

To all whom it may concern:

Be it known that I, EDWIN PRESCOTT, a citizen of the United States, and a resident of Arlington, in the county of Middlesex and State of Massachusetts, have invented an Improvement in Centrifugal Railways, of which the following description, in connection with the accompanying drawings, is a specification, like characters on the drawings representing like parts.

This invention is intended as an improvement upon the railway represented in United States Patent No. 609,164, dated August 16, 1898, the improvements aiming to construct the loop as to tend to the comfort of the passenger as the car enters the loop. In the patent referred to the upper and lower parts of the track in the loop are each circular, and the movement of the car in entering the loop gives to the passengers a sort of shock which to some passengers is objectionable. Herein the curve of the loop is definite, and the car rides on a lower part of the track, both before and preferably after leaving the loop, and the curve in the lower part of the loop starts from its lowest point and approaches the horizontal diameter of the loop in a curve of decreasing radius, so that the turn given to the car when at its fastest speed and lowest point is on the largest part of the curve and the shock is less severe. As the car passes about the interior of the upper part of the loop and starts to descend it meets substantially at the horizontal diameter of the loop a portion of the track having a curve which constantly increases from substantially the horizontal diameter of the track, and the lowest point in this curved portion of the track is beyond the passing-point of the track in the formation of the loop. It will be understood that a track laid in the form of a loop, as herein provided for, must pass at some point, thus giving a sort of screw tendency to the track, said track as the car travels over it behaving with relation to the car like a square-threaded screw, and it will therefore be understood that any car to safely ride the loop throughout must have such a construction that the wheels at one end of the car may follow the track irrespective of the position of the car-body or of the wheels at the opposite end of the car. In the patent referred to provision

was made to joint the car-truck between its ends, and for this purpose a lever extended backwardly from the frame carrying the front wheels was slotted to embrace a pin of the lever connected with the frame carrying the rear wheels; but in practice this pin-and-slot connection was found to present more looseness than was desirable when the car was running on a straight portion of the track. To obviate this loose joint and insure a more steady running of the car, I have provided a novel joint which will enable the frame carrying the front wheels, as well as the frame carrying the rear wheels, to move with relation to the car when following the curved track. The new joint or connection is composed of devices having a sliding and rolling fit, one in the other, and one of the parts is capable of oscillating back and forth about a vertical plane intersecting the body of the truck-frame. Herein I have provided novel means for sustaining the arms carrying the wheels cooperating with the track to control the swinging of the truck-frame as its wheels follow the curve of the track. The track of the centrifugal railroad starts from a turn-table upon which a car, having passed the loop and been stopped at the disembarking-point, is brought by a suitable elevating mechanism, which may be an endless chain, and to check or arrest the car at the proper position upon the turn-table I have provided the latter with a friction device, which engages the car when it arrives at the desired position on the turn-table. A car having been deposited upon the turn-table the turn-table is rotated, swinging the car until the rails upon which it rests are alined with the starting end of the centrifugal-railway track, and thereafter the brake is released, preparatory to starting the car down the incline.

The particular features in which my present invention resides will be hereinafter more fully described, and pointed out in the claims at the end of this specification.

Figure 1 is a perspective view of a centrifugal railway embodying my present invention, part of the guard-rails of the track being omitted to avoid confusion in the drawings; Fig. 2, a plan view of the loop part of the track, showing how the track is bent to constitute a passing-point. Fig. 3 is a diagram

showing the spiral shape of the track, the loop, and the lowest point of the track at the incoming and outgoing parts of the loop. Fig. 4 is an enlarged plan view showing the upper end of the incline with its turn-table and connected car-brake. Fig. 5 is a side elevation of Fig. 4. Fig. 6 is a plan view of the car located at the disembarking-point of the track, the dotted lines showing the means for controlling the relative change of position of the front and rear wheel with relation to the body of the car. Fig. 7 is an end view of the car looking at it from the rear end. Fig. 8 is a diagram showing the car in side elevation with the front and rear wheels on the main track, together with part of the safety-track. Fig. 9 is an end view of the car looking at it at its front end; Fig. 10, an under side view of the car represented in Fig. 8 while in the loop, the wheels running on a curved part of the track.

The uprights a , sleepers or rail-supports a' , the passenger-station d , the car-tracks b b' , and the safety-rails m , suitably sustained by braces m' , are and may be as fully described in my said patent or of any suitable construction, so long as said tracks sustain the wheels A' of the car-body A , to be described, in its regular motion inside the loop B , to be described, made in the track, and prevent the car from leaving said tracks in case of any accident to negative the action of centrifugal motion in keeping the car running about the loop made in the track.

I find that in the practical use of the railway shown in said patent, the loop of track inside which the car travels being substantially circular, and that inasmuch as the car starts upwardly within the loop at the passing-point of the track used to form the loop, a sensation as of a shock is felt as the car starts in its circular movement. In my studies to improve the railway shown in said patent I have discovered that the sensation of shock may be materially lessened by so shaping the track that its lowest point will be in the arc of a circle of larger radius than other parts of the loop, or, in other words, that the lowest point of the track over which the car passes in its approach to turn through the loop is located outside the passing-point of the track forming the loop, said passing-point being at the lower side of the spiral loop, the point where the car enters and leaves the loop. This feature of my invention, which is a matter of the greatest possible advantage in the practical use of a railway of the class described, is illustrated in Fig. 1 and in the diagram Fig. 3, which shows the shape of the loop in one of the best forms now known to me. Viewing Fig. 3, b represents the track, and B the shape of the loop in the track. The arrows show the direction of movement of the car in making a circuit of the railway, and it will be seen that the loop is of greater diameter in a vertical line 2, cutting the line 3, which designates the horizontal diameter of

the loop, and with a loop of such shape it will be noticed that the track outside the loop and leading the car into the loop is of a radius greater than other parts of the track inside the loop, and that the lowest part of the track is located near the loop outside the passing-point of the track forming the loop, so that the turning of the car from the inclined to the curved part of the track takes place while the car is moving at its greatest speed, and the turn of the car is begun outside the loop, where the track is lower than any part of the track in the loop between the passing-point.

This invention is not limited to the particular radius of the track in the under half of the loop and in the track approaching and leaving the loop so long as the radius is such as to leave outside the incoming side of the loop a portion of the track lower than any part of the track bounded by the loop, and preferably for the best results this same condition will obtain in the part of the track leaving the loop. I find that I gain excellent results by varying the curve of the track leading from its lowest point outside the loop substantially to the horizontal diameter of the loop, so that the radius differs, the radius decreasing as the track approaches the horizontal diameter of the loop. This shape of track affords a more gradual and easier turn, and as the car descends in the loop in which the track is laid increases until the car has gone beyond the passing-point preparatory to ascending, as herein shown, the incline located beyond the loop.

I have shown the railway as provided with a guide rail or device o , effective in changing the position of the carrier for the wheels of the car running on the tracks b and b' , and this rail may be the same as provided for in said patent and be located between the tracks; but the invention is not limited to making the guide-rail exactly as shown, but the guide-rail should follow the general trend of the track.

I have located at the upper end of the first incline C of the railway a turn-table D , sustained revolubly in any usual way on a framework D' , said table being provided at its surface with two lines of tracks D^2 and D^3 , said tracks in pairs being inclined, respectively, in opposite directions, (see Fig. 5,) so that whenever a car A is put onto the turn-table said car will by gravity tend to move to the outer end of said track, and to check this movement I have added to the turn-table a suitable brake E , adapted in the form in which I have chosen to illustrate it to act on the sides of the wheel of the car; but, if desired, the brake might act on any other part of the car.

I have shown the turn-table as provided with two brakes, one for each track, and each may be operated independently of the other to check a car or enable it to be released that it may start or be started down the incline C . The end of the track of the turn-table having on it the car A about to descend said incline is

lowest next the upper end of the incline, so that the car may be aided by gravity in getting onto the track of said incline. I have herein shown said brakes as supported on radius-bars e , which at their ends carry the brake, and the links are moved to actuate the brake by a suitable shaft and connections. The brake at one side the track (marked D^2) is so located and held that it acts to stop the car automatically, and the brake having acted to stop the car the turn-table is partially rotated until the rails D^2 occupy the position of the rails D^3 . To release the car that it may run onto the tracks of the incline C, the attendant will turn the shaft e' , putting the handle thereof temporarily in the dotted-line position shown in Fig. 4, thus moving the brake into the dotted-line position to release the car, and the car having passed onto the incline C the operator releases the shaft e' , letting a suitable device, as e^2 , which may be a spring or weight acting normally, restore the brake into its operative position, as shown next the track D^2 .

The turn-table may be rotated at the desired times by a belt f , driven by a pulley f' , said belt entering a hub f^2 , connected with the turn-table. The pulley f' is actuated from or by a toothed gear f^3 , which may be driven by a pinion f^4 , attached, preferably, to a shaft f^5 , carrying part of the means for elevating the car from the passenger-platform to the turn-table.

The elevator may be of any usual or suitable kind adapted to engage a car at the station d , carrying it up, and delivering the car on the track of the turn-table. I have shown the elevator as having a chain moved by a sprocket-wheel.

The car-truck and its frame, the wheels A' to run on the track, and the wheels n^2 , forming part of the safety device which I have herein chosen to illustrate, the front and rear axles for said wheels A' , the pivoted frames for said axles, one of said frames also being free to oscillate in a vertical circle at right angles to the direction of movement of the car, are and may be substantially as represented in said patent.

The frames described in said patent had extended from them toward the center of the car arms or levers, which were united by a pin in one arm entering loosely a slot in the other arm, and one of said arms sustained rollers 6, also herein shown, which contacted with the guide-rail. In practice it has been found that the pin-and-slot connection permitted excessive looseness, which caused the car to run unsteadily, and to prevent this unsteady movement in the running of the car I have devised a novel connection for said arm whereby looseness of movement of one of said arms on or with relation to the other is done away with and the arms are connected by devices having a working fit. The wheels 6 run on studs 7, extended through two like plates 8 and 9, suitably secured to the arm 10, ex-

tended from the frame carrying the rear wheels. Centrally between these two plates I have pivotally mounted a guide-block 12, having a horizontal hole 13, (see Fig. 7,) which receives as a working fit the round part 14 of the end of the arm 15, extended from the frame carrying the axle for the front wheels. Connecting the arms as described by devices having a sliding fit and capable of substantially universal movement without lost motion is of great value in steadying the motion of a track-frame traveling on a spiral track. Herein I have provided novel means for steadying the movement of the plates 8 and 9 and arms carrying the rollers 6, said means consisting of an arm 17, extended upwardly from one of said plates and provided with a roller 18, adapted to run on a curved track 19, sustained in any suitable manner at the bottom of the car.

Having described my invention, what I claim as new, and desire to secure by Letters Patent, is—

1. In a centrifugal railway, a spirally-arranged track presenting a substantially vertical loop, the lowest point of the track leading to the loop being located at one side of a vertical plane through the center of the loop substantially at right angles to the track.

2. In a centrifugal railway, a spirally-arranged track presenting a substantially vertical loop, said track beyond and outside the loop on which the car travels being lower than any part of the track in the loop.

3. In a centrifugal railway, a spirally-arranged track presenting a substantially vertical loop, parts of the track approaching and leaving the point where the track passes in the formation of the loop being located at a lower level than any part of the track forming the inner walls of the loop.

4. In a centrifugal railway, an inclined track laid in spiral form from its lowest point to form a loop of decreasing radia from said lowest point substantially to the horizontal diameter of the loop.

5. In a centrifugal railway, an inclined track laid in spiral form from its lowest point to form a loop of decreasing radia from said lowest point substantially to the horizontal diameter of the loop, said track being laid from said horizontal diameter to the lowest point of the track leading the car out of the loop in a spiral curve of increasing radia.

6. In a centrifugal railway, a spiral track having a portion thereof laid as a loop about and within which a car may run, said loop presenting a smaller radia above its horizontal diameter, the tracks in that part of the loop below its horizontal diameter being laid in arcs of larger circles, said arcs being carried beyond the point where the tracks pass in the formation of the loop to thereby leave the lowest points of the track in front of and behind a vertical plane intersecting the loop at right angles to the track.

7. In a centrifugal railway, a track laid as

a spiral loop, the track leading to the point where the tracks pass in the formation of the loop and the track leading outwardly from said loop at its passing-point presenting 5 curves occupying a lower level than portions of the track at said passing-point.

8. In a centrifugal railway, a track bent and laid in a spiral curve to form a loop, the track passing below the horizontal diameter 10 of the loop, the spiral trend of the track being extended beyond the side crossing-point to constitute a portion of track approaching the loop which is lower than any point of the loop between said passing-point.

9. In a centrifugal railway, a spirally-arranged track presenting a loop, the lowest 15 point of the track being located at one side of a vertical plane through the center of the loop substantially at right angles to the track, a car adapted to travel said spirally-arranged 20 track and run about within the interior of said loop, and safety appliances to prevent the car leaving the track in case the car should be arrested in its movement in the loop.

10. In a centrifugal railway, a spirally-arranged track presenting a loop, inclined portions 25 behind and in front of said loop in the direction of movement of the car, said track approaching the loop being lower than any portion of the track constituting the walls of 30 the loop, a passenger-station, a turn-table, and means to elevate the car and place it upon a track of the turn-table.

11. In a centrifugal railway, a spirally-arranged track presenting a loop, inclined portions 35 behind and in front of said loop in the

direction of movement of the car, said track approaching the loop being lower than any portion of the track constituting the walls of the loop, a passenger-station, a turn-table, 40 means to elevate the car and place it upon a track of the turn-table, and a brake acting to determine the position of the car on the track of the turn-table.

12. In a centrifugal railway, a car, frames 45 pivotally mounted at the ends of said cars to receive the axles carrying the wheels sustaining said car, arms connected with said frames, and extended one toward the other, and a universal connection between said arms hav- 50 ing a working fit to thereby obviate any lost motion yet permit the arms to change their position that the wheels may follow the curves of the track and run steadily thereon.

13. In a centrifugal railway, having a spi- 55 rally-arranged track, a car having frames pivotally mounted thereon for the axles carrying the wheels to run on said track, arms extended toward each other from said frames, a guide-rail, rollers sustained by said arms 60 and coacting with said rail, a track, and a roller connected with one of said arms and running on said track to sustain the weight of the arms and their rollers.

In testimony whereof I have signed my 65 name to this specification in the presence of two subscribing witnesses.

EDWIN PRESCOTT.

Witnesses:

GEO. W. GREGORY,
EDITH M. STODDARD.