



US00D953989S

(12) **United States Design Patent**
Egawa

(10) **Patent No.:** **US D953,989 S**
(45) **Date of Patent:** **** Jun. 7, 2022**

(54) **CONNECTOR**

(71) Applicant: **Molex, LLC**, Lisle, IL (US)

(72) Inventor: **Toyokazu Egawa**, Yamato (JP)

(73) Assignee: **Molex, LLC**, Lisle, IL (US)

(**) Term: **15 Years**

(21) Appl. No.: **29/706,758**

(22) Filed: **Sep. 24, 2019**

(30) **Foreign Application Priority Data**

Mar. 26, 2019 (JP) 2019-006403

(51) **LOC (13) Cl.** **28-03**

(52) **U.S. Cl.**

USPC **D13/133**; D13/151

(58) **Field of Classification Search**

USPC D13/133, 146, 147, 123, 184, 199, 118,
D13/120, 154, 155, 173, 156, 121, 161,
D13/175, 103, 158, 162, 162.1, 149, 150,
D13/151, 153

CPC ... H01R 3/00; H01R 4/00; H01R 9/00; H01R
9/03; H01R 9/05; H01R 9/0503; H01R
9/0506; H01R 9/0521; H01R 9/16; H01R
9/18; H01R 9/22; H01R 9/2408; H01R
9/2416; H01R 9/2425; H01R 11/00;
H01R 11/282; H01R 11/283; H01R
12/00; H01R 12/58; H01R 12/592; H01R
13/00; H01R 13/005; H01R 13/207;
H01R 13/46; H01R 13/52; H01R 13/506;
H01R 13/514; H01R 13/629; H01R
13/62933; H01R 13/64; H01R 24/00;
H01R 24/20; H01R 24/38; H01R 25/00;
H01R 2201/00; H01R 2201/18

See application file for complete search history.

(56) **References Cited**

U.S. PATENT DOCUMENTS

1,568,156 A 1/1926 Herskovitz
4,707,043 A 11/1987 Reed

4,820,179 A 4/1989 Saijo
4,917,625 A 4/1990 Haile
5,124,876 A 6/1992 Misencik et al.
5,190,475 A 3/1993 Dickens

(Continued)

FOREIGN PATENT DOCUMENTS

CN 1759507 A 4/2006
CN 1783611 A 6/2006

(Continued)

OTHER PUBLICATIONS

Amphenol Switching Stereo Jack. Date: Feb. 6, 2014. [online]. [Site visited Jul. 2, 2021], Available from Internet URL: <https://www.amazon.co.uk/dp/B0070Z827G/> (Year: 2014).*

(Continued)

Primary Examiner — Susan Bennett Hattan

Assistant Examiner — Landon Thomas Cassell

(57) **CLAIM**

The ornamental design for a connector, as shown and described.

DESCRIPTION

FIG. 1 is a perspective view of connector showing our new design;
FIG. 2 is a front view thereof;
FIG. 3 is a rear view thereof;
FIG. 4 is a top view thereof;
FIG. 5 is a bottom view thereof;
FIG. 6 is a right side view thereof;
FIG. 7 is a left side view thereof; and,
FIG. 8 is a perspective view thereof in use.
The broken lines in the drawings depict portions of the connector that do not form a part of the claimed design.

1 Claim, 4 Drawing Sheets

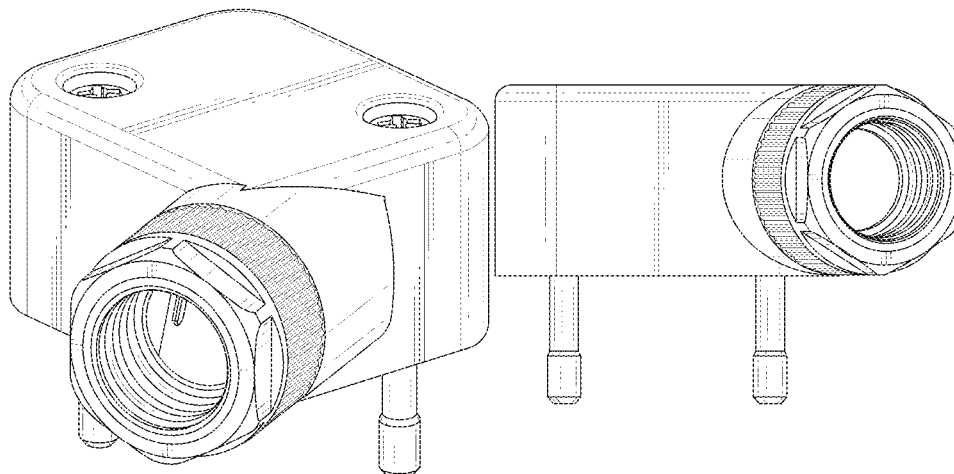

(56)

References Cited

U.S. PATENT DOCUMENTS

5,352,850 A 10/1994 Norris
 5,354,850 A 10/1994 Von et al.
 5,697,806 A 12/1997 Whiteman, Jr. et al.
 D411,828 S 7/1999 Min
 6,179,653 B1* 1/2001 Cheng H01R 9/2408
 439/541.5
 6,475,036 B2 11/2002 Morikawa
 6,692,310 B2 2/2004 Zaderej et al.
 7,438,604 B2 10/2008 Andresen
 D594,415 S* 6/2009 Shitakata D13/133
 7,544,074 B2 6/2009 Buck et al.
 7,753,740 B2 7/2010 Carolis et al.
 8,007,312 B2 8/2011 Bower et al.
 8,043,114 B2 10/2011 Kaneko et al.
 8,206,159 B2 6/2012 Naito et al.
 D720,698 S* 1/2015 Zerebilov D13/147
 9,048,569 B2 6/2015 Chen
 D740,759 S* 10/2015 Fukushima D13/151
 9,343,860 B2 5/2016 Zomchek et al.
 D759,594 S* 6/2016 Kato D13/133
 9,450,319 B2 9/2016 Nishimura
 D784,929 S* 4/2017 Makimura D13/147
 10,143,102 B2 11/2018 Bury et al.
 D845,893 S 4/2019 Kim et al.
 D850,381 S 6/2019 Tabata et al.
 D892,728 S 8/2020 Pan
 2002/0197893 A1 12/2002 Hiroyuki et al.
 2004/0157498 A1* 8/2004 Hall H01R 13/6456
 439/680
 2007/0049121 A1* 3/2007 Steele H05K 3/284
 439/630
 2007/0072488 A1* 3/2007 Xue H01R 13/652
 439/544
 2009/0137133 A1* 5/2009 Gou H01R 43/205
 439/63
 2013/0217262 A1 8/2013 Ikeda et al.
 2015/0303615 A1* 10/2015 Daugherty, Jr. G02B 6/3887
 385/55
 2015/0340788 A1 11/2015 Sakaue et al.
 2015/0357735 A1 12/2015 Uratani
 2016/0006162 A1* 1/2016 Andresen H01R 13/5208
 439/587
 2016/0164232 A1* 6/2016 Lane H01R 24/50
 439/578
 2016/0285190 A1* 9/2016 Guo H01R 4/2433
 2018/0037177 A1 2/2018 Dietrich et al.

2019/0109408 A1* 4/2019 Maddens H01R 12/716
 2020/0099168 A1 3/2020 Inoue et al.
 2020/0153153 A1* 5/2020 Chang H01R 12/722
 2020/0176900 A1 6/2020 Egawa
 2020/0194949 A1 6/2020 Egawa
 2020/0212608 A1 7/2020 Egawa
 2020/0251855 A1 8/2020 Chen

FOREIGN PATENT DOCUMENTS

CN 201112707 Y 9/2008
 CN 202068039 U 12/2011
 CN 102403683 A 4/2012
 CN 203850506 U 9/2014
 CN 206412796 U 8/2017
 JP S54-41590 U 3/1979
 JP H06-52907 A 2/1994
 JP H08-115759 A 5/1996
 JP 3135006 B2 2/2001
 JP 2010-252543 A 11/2010
 TW D156015 S1 9/2013
 TW D187173 S1 12/2017
 TW D188008 S 1/2018
 TW D189476 S 4/2018
 TW D189478 S 4/2018

OTHER PUBLICATIONS

COOLWEST Waterproof Outdoor Connector. Date: Mar. 11, 2016. [online]. [Site visited Jul. 2, 2021], Available from Internet URL: <https://www.amazon.co.uk/dp/B01CTN7KBW/> (Year: 2016).*

Sourcing map—PCB Mount. Date: Mar. 8, 2019. [online], [Site visited: Jul. 12, 2021], Available from Internet URL: <https://www.amazon.co.uk/dp/B07PDYH8KW/> (Year: 2019).*

Connectors. (Design—© Questel) orbit.com. [Online PDF compilation of references] 26 pgs. Print Dates Range May 9, 2005-Apr. 12, 2017 [Retrieved Jul. 8, 2021] <https://www.orbit.com/export/UCZAH96B/pdf4/acacd21d-0358-4216-befa-f190f59a73d2-211427.pdf> (Year: 2021).*

Non-Final office action received for U.S. Appl. No. 16/693,379 dated Sep. 1, 2020, 7 pages.

Non-Final office action received for U.S. Appl. No. 16/693,388 dated Sep. 16, 2020, 6 pages.

Non-Final office action received for U.S. Appl. No. 16/693,391 dated Sep. 30, 2020, 13 pages.

Non-Final office action received for U.S. Appl. No. 29/706,412 dated Oct. 6, 2020, 9 pages.

* cited by examiner

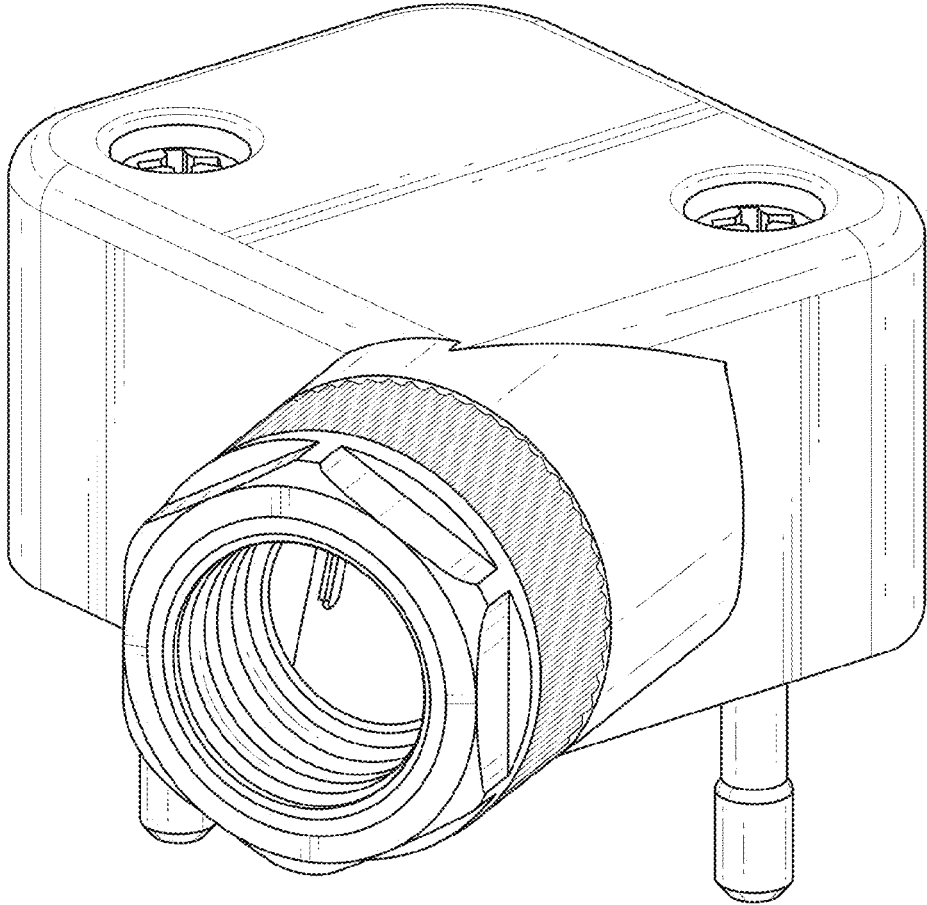

FIG. 1

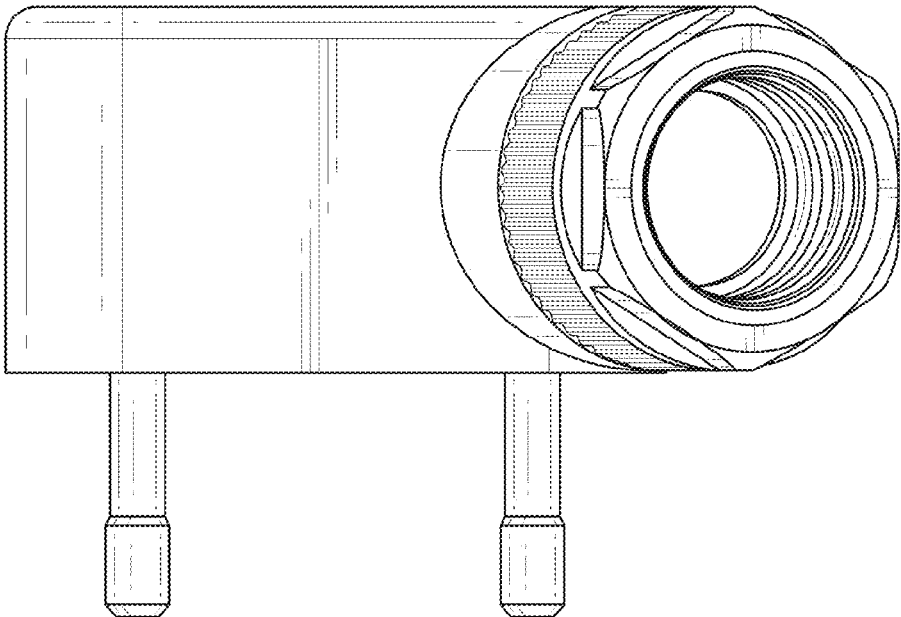

FIG. 2

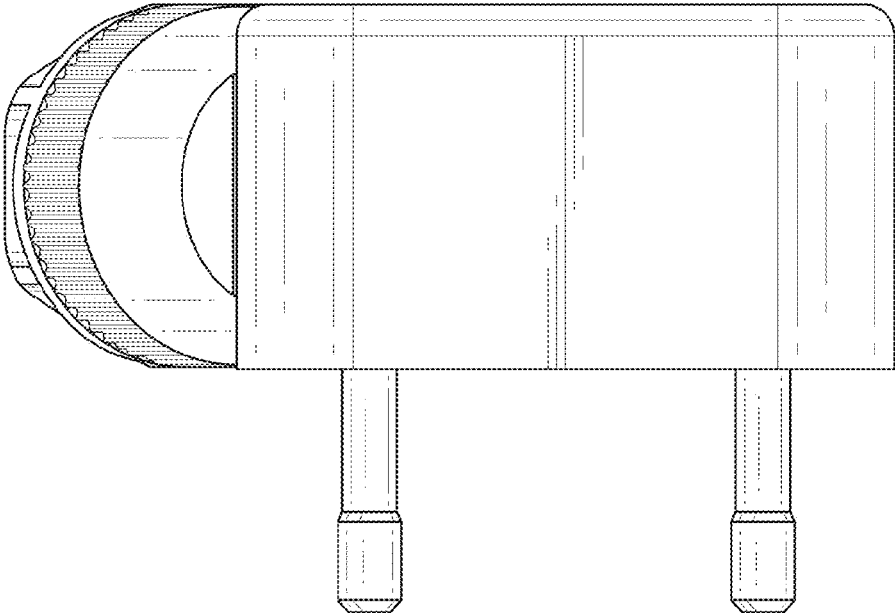

FIG. 3

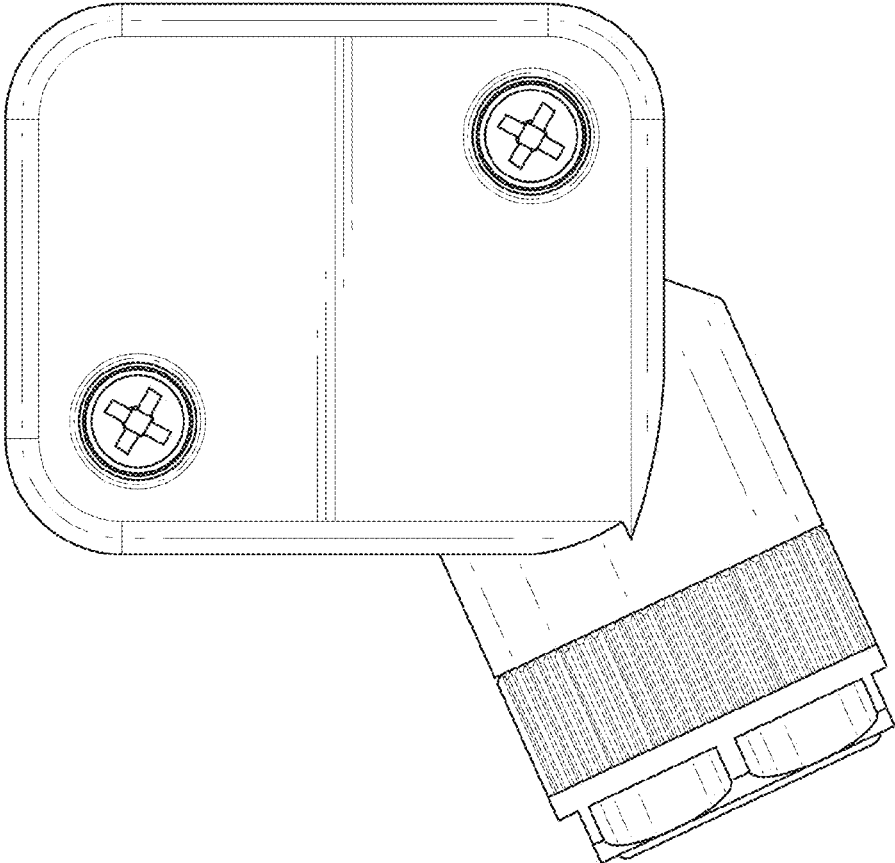

FIG. 4

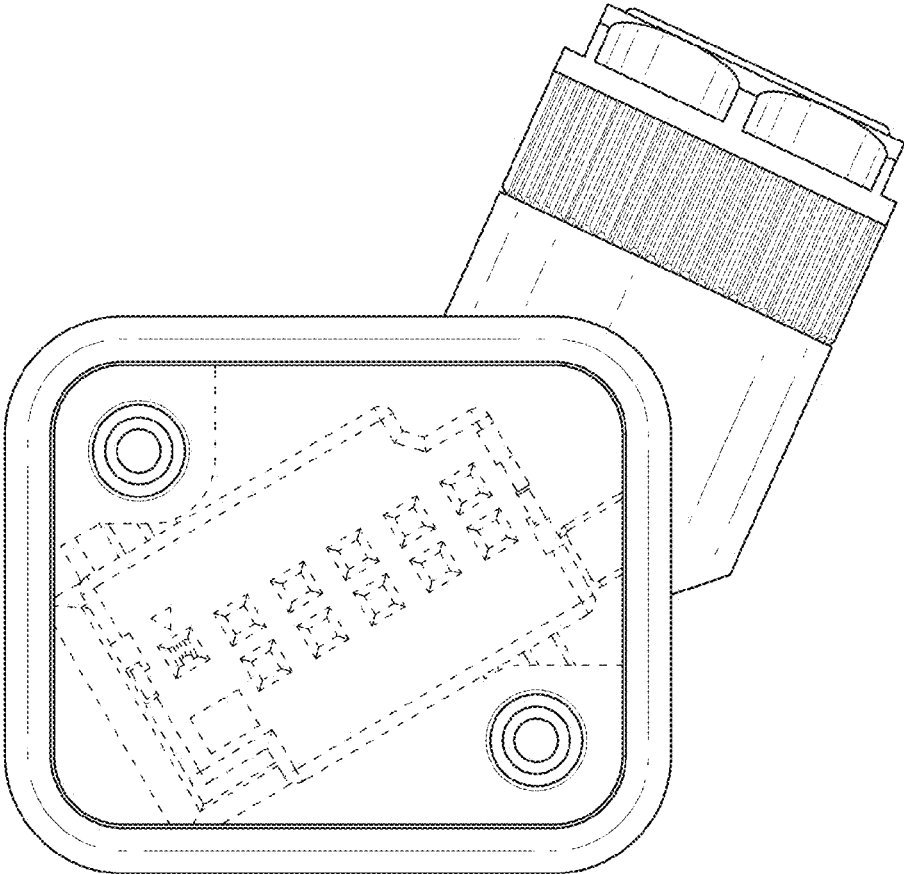

FIG. 5

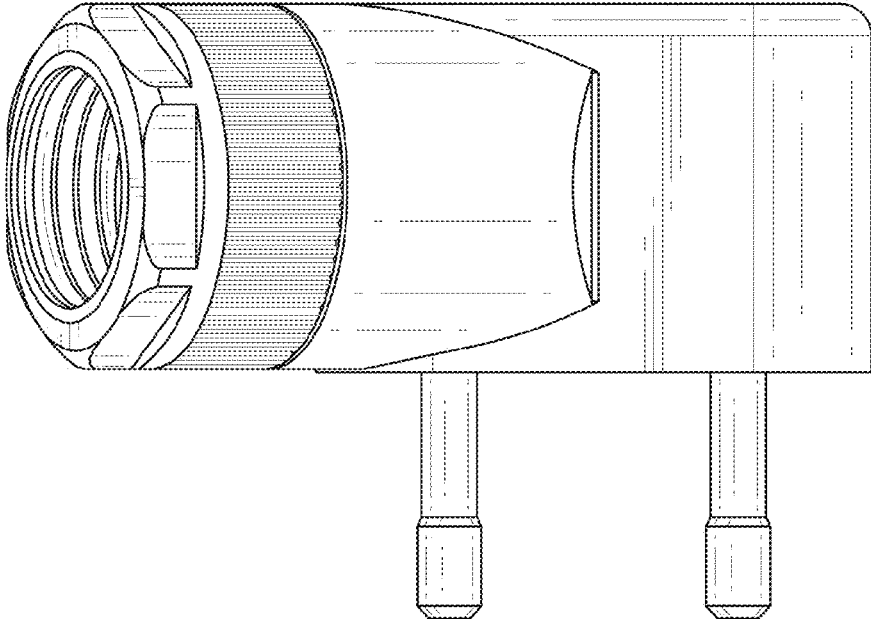

FIG. 6

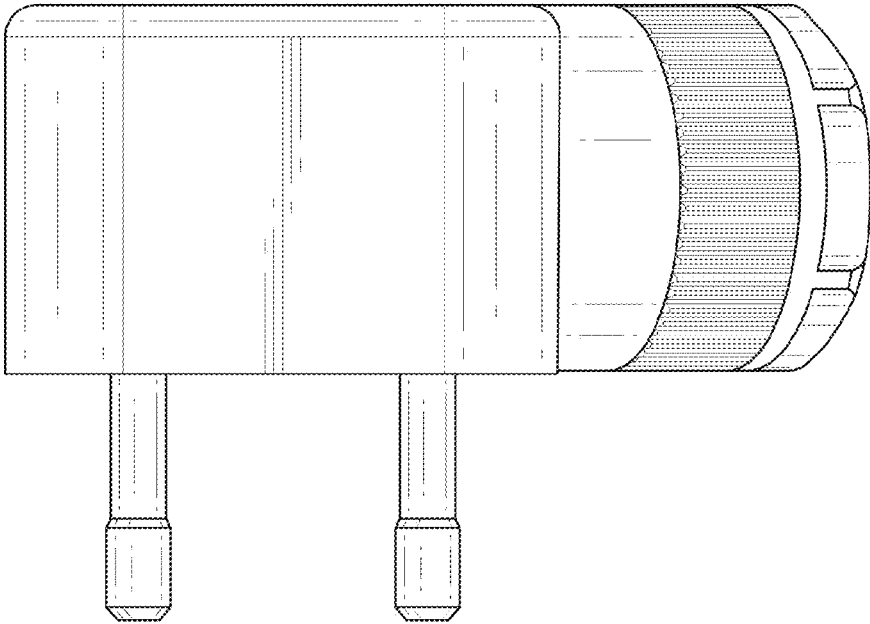

FIG. 7

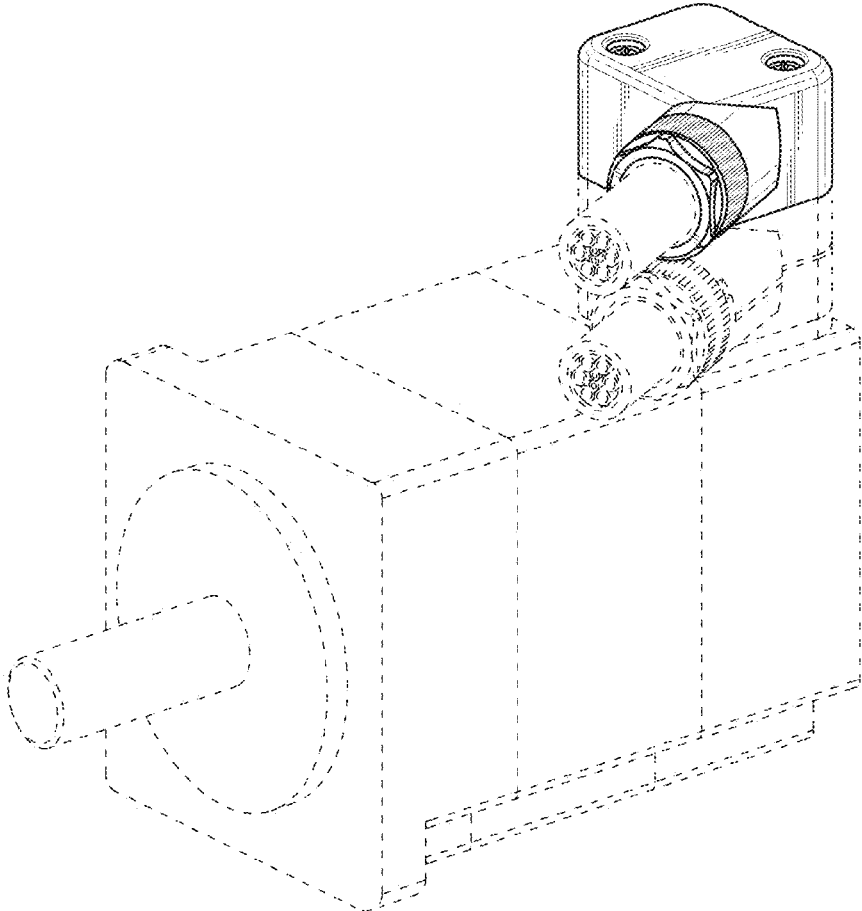

FIG. 8