



US 20180214263A1

(19) **United States**

(12) **Patent Application Publication**  
**ROLANDO et al.**

(10) **Pub. No.: US 2018/0214263 A1**

(43) **Pub. Date: Aug. 2, 2018**

(54) **VALVULAR SLEEVE FOR VALVULAR PROSTHESES AND CORRESPONDING DEVICE**

**Publication Classification**

(51) **Int. Cl.**  
*A61F 2/24* (2006.01)  
(52) **U.S. Cl.**  
CPC .... *A61F 2/2418* (2013.01); *A61F 2220/0033* (2013.01); *A61F 2230/001* (2013.01); *A61F 2220/0075* (2013.01); *A61F 2210/0014* (2013.01); *A61F 2220/005* (2013.01); *A61F 2220/0058* (2013.01); *A61F 2/2475* (2013.01)

(71) Applicant: **Sorin Group Italia S.r.l.**, Milano (IT)

(72) Inventors: **Giovanni ROLANDO**, Chivasso (TO) (IT); **Paolo GASCHINO**, Castagneto Po (Torino) (IT)

(21) Appl. No.: **15/746,747**

(22) PCT Filed: **Jul. 19, 2016**

(86) PCT No.: **PCT/IB2016/054281**

§ 371 (c)(1),

(2) Date: **Jan. 22, 2018**

(30) **Foreign Application Priority Data**

Jul. 22, 2015 (IT) ..... 102015000037126

(57) **ABSTRACT**

A valvular sleeve for valvular prostheses including a tubular body extending between an inflow end and an outflow end, the tubular body including a sheet member folded at the outflow end, whereby the tubular body includes an inner tubular portion and an outer tubular portion surrounding the inner tubular portion.

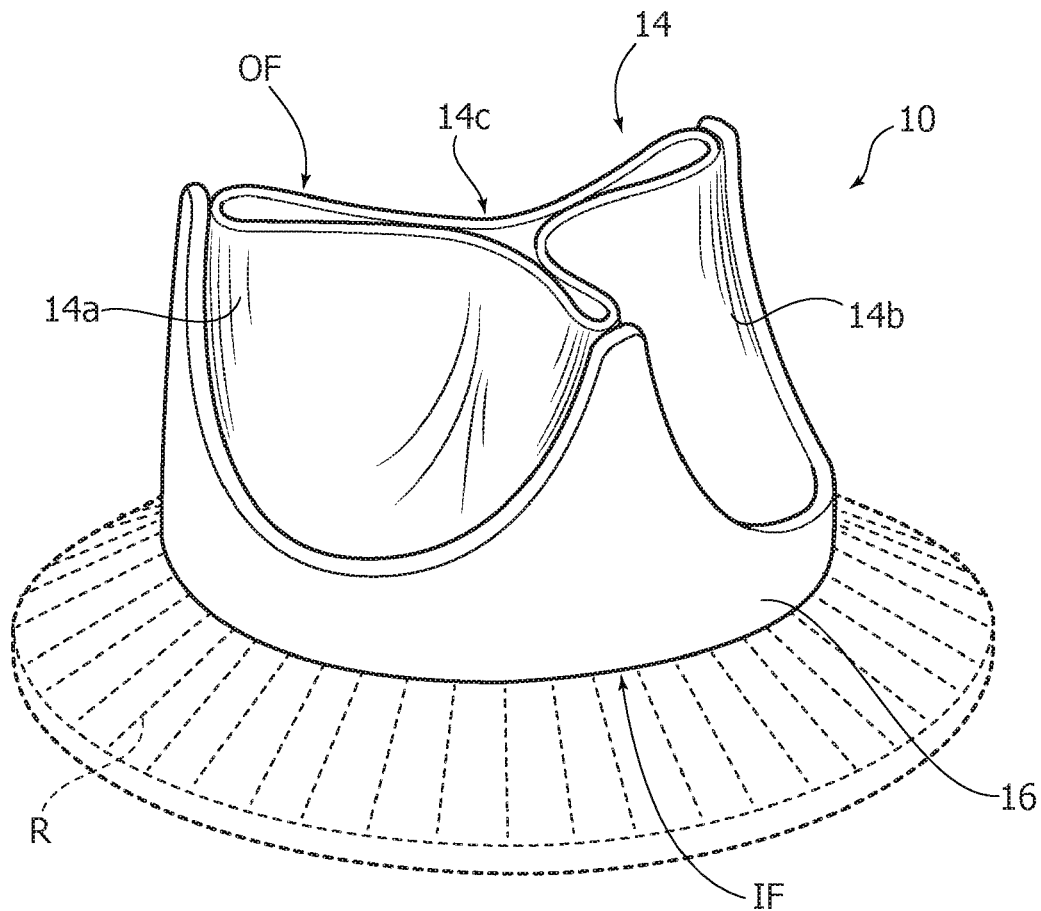

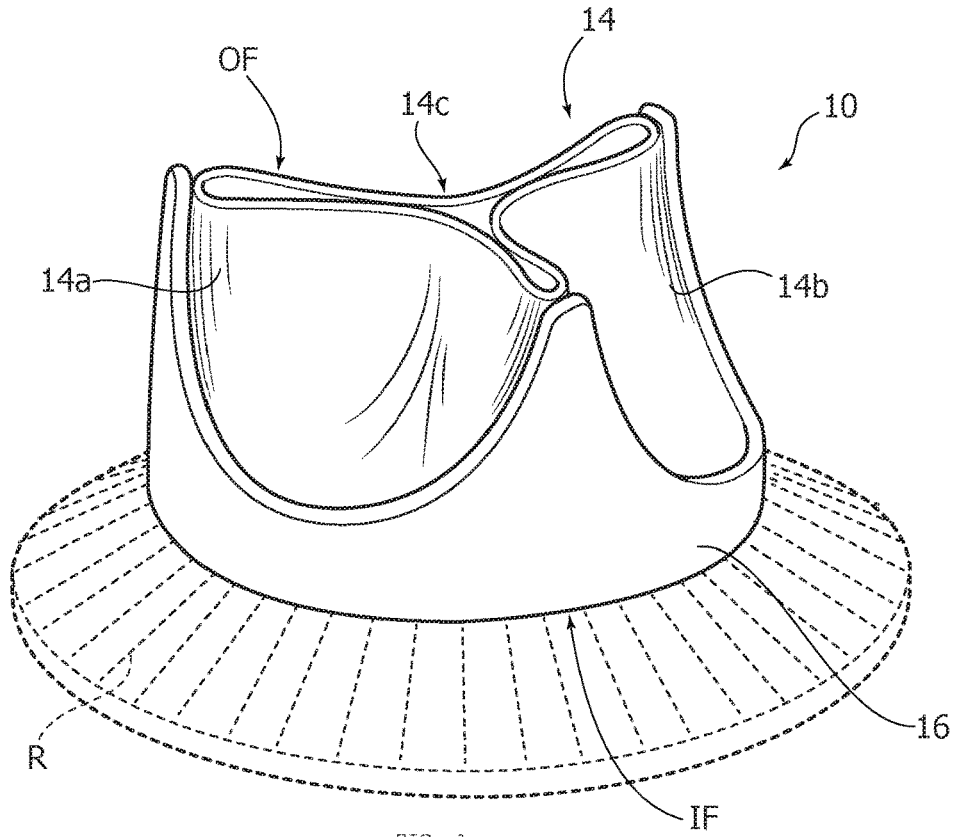

FIG. 1

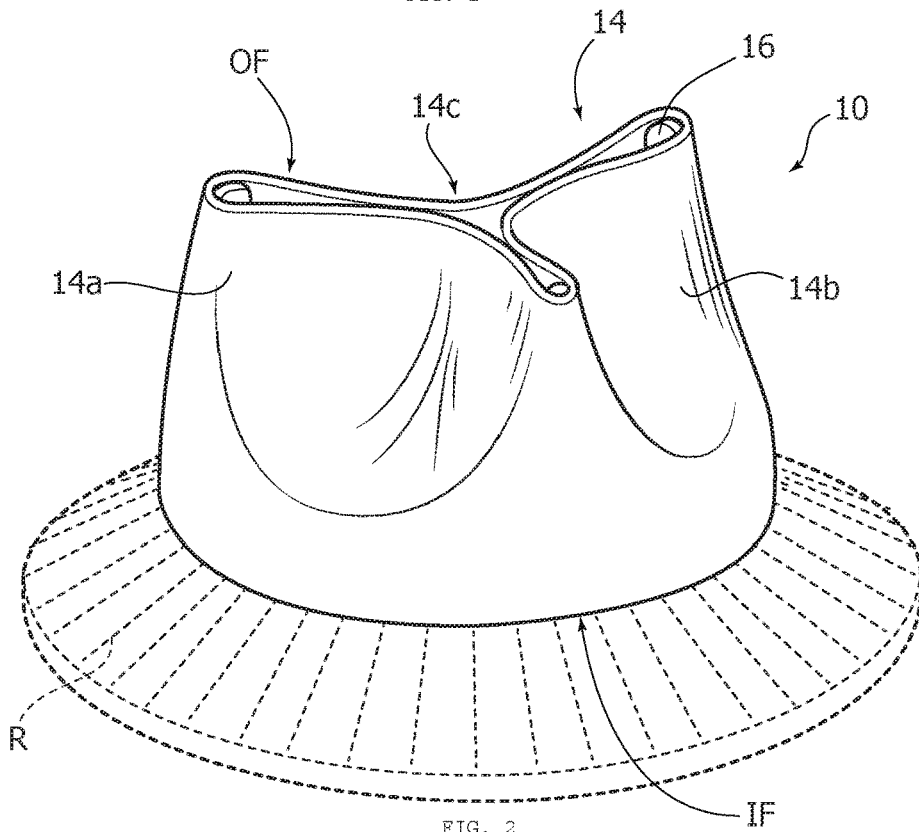

FIG. 2

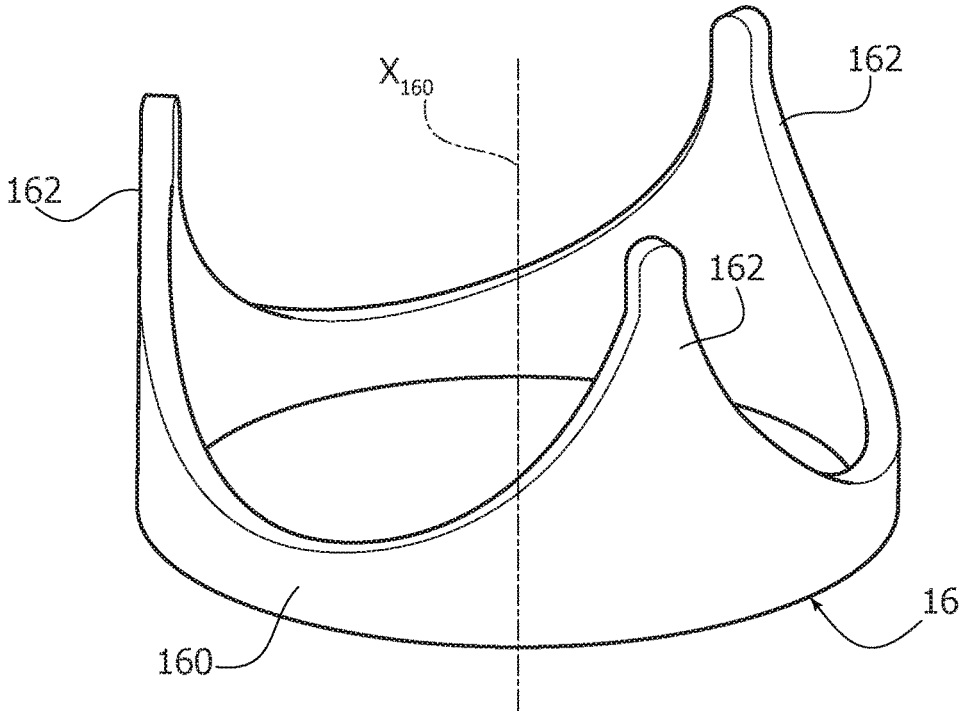

FIG. 3

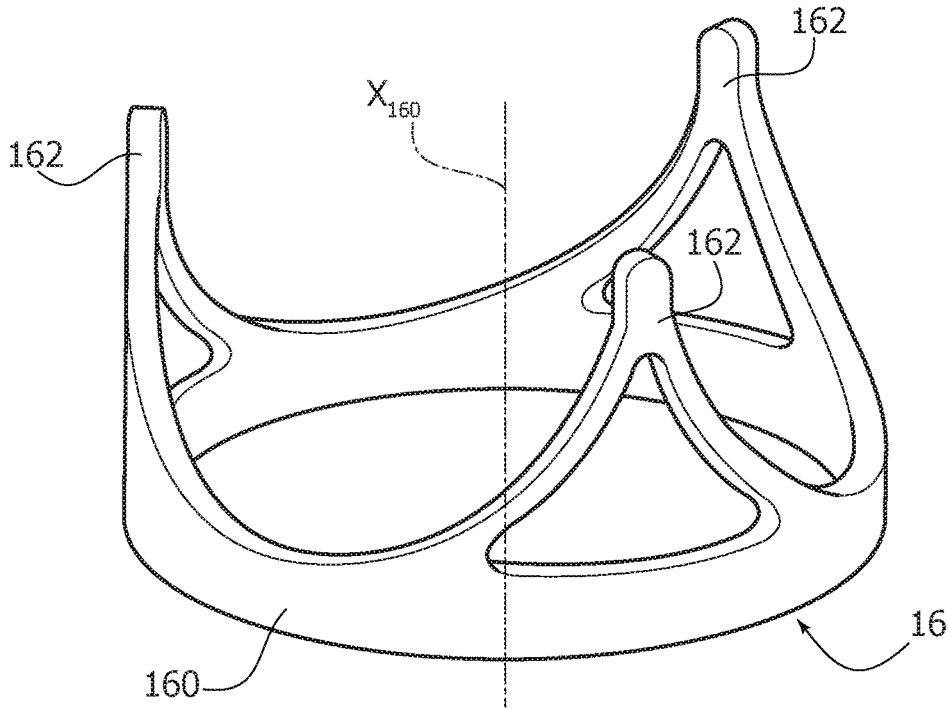

FIG. 4

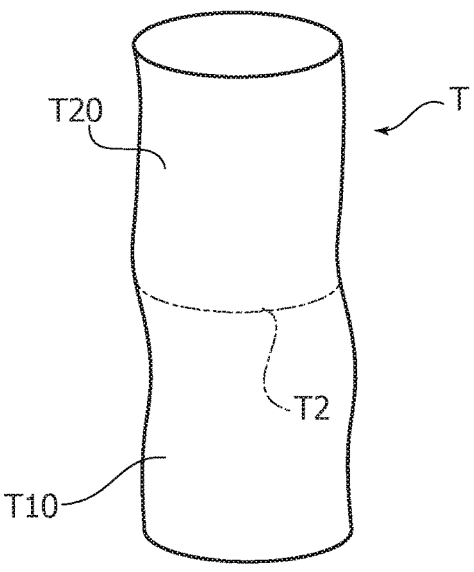

FIG. 5A

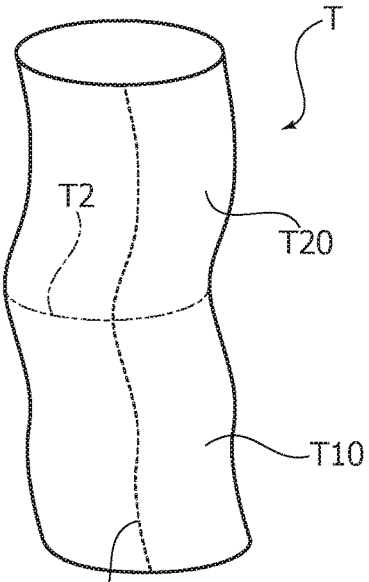

FIG. 5B

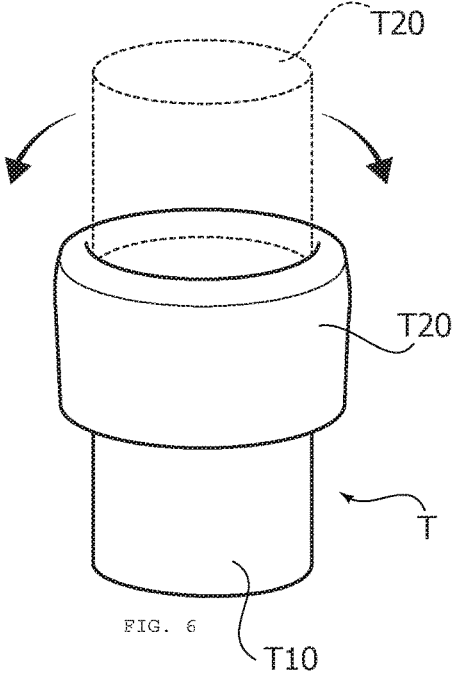

FIG. 6

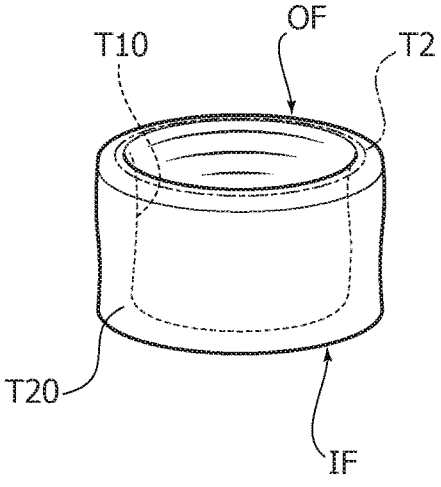
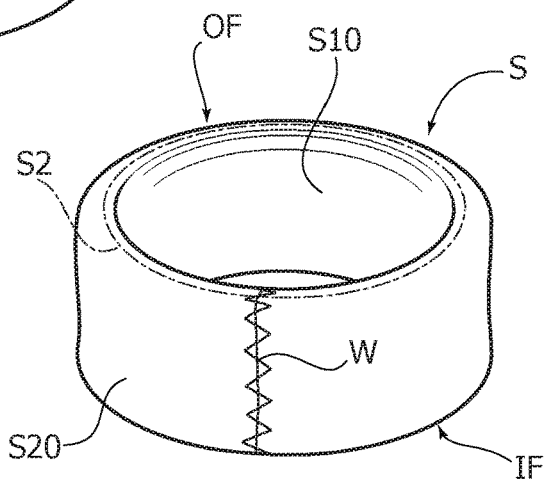
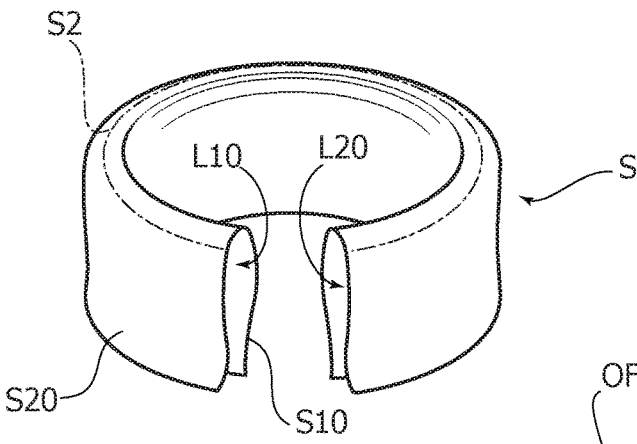
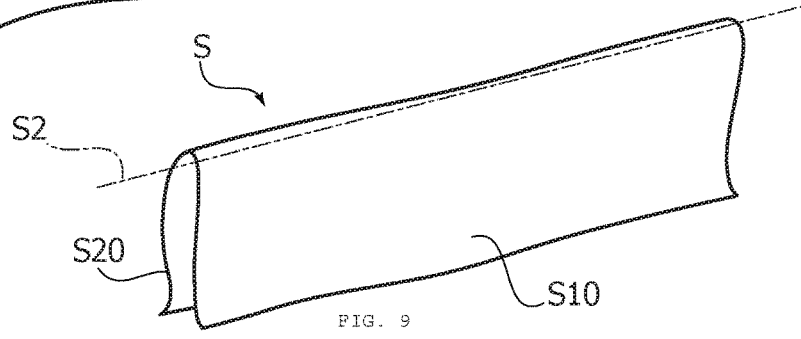
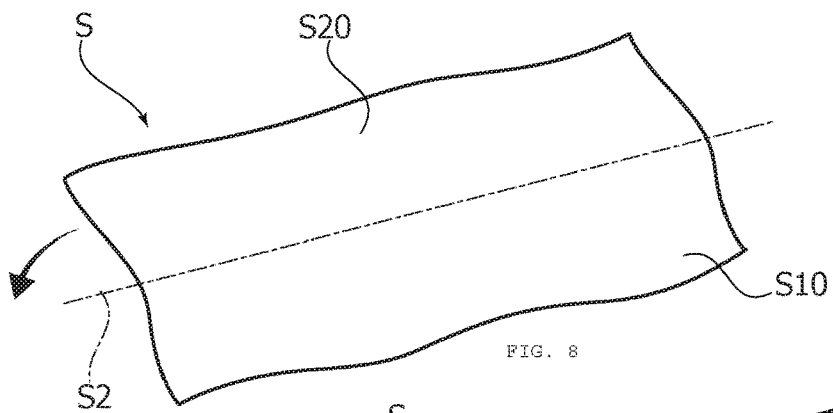

FIG. 7



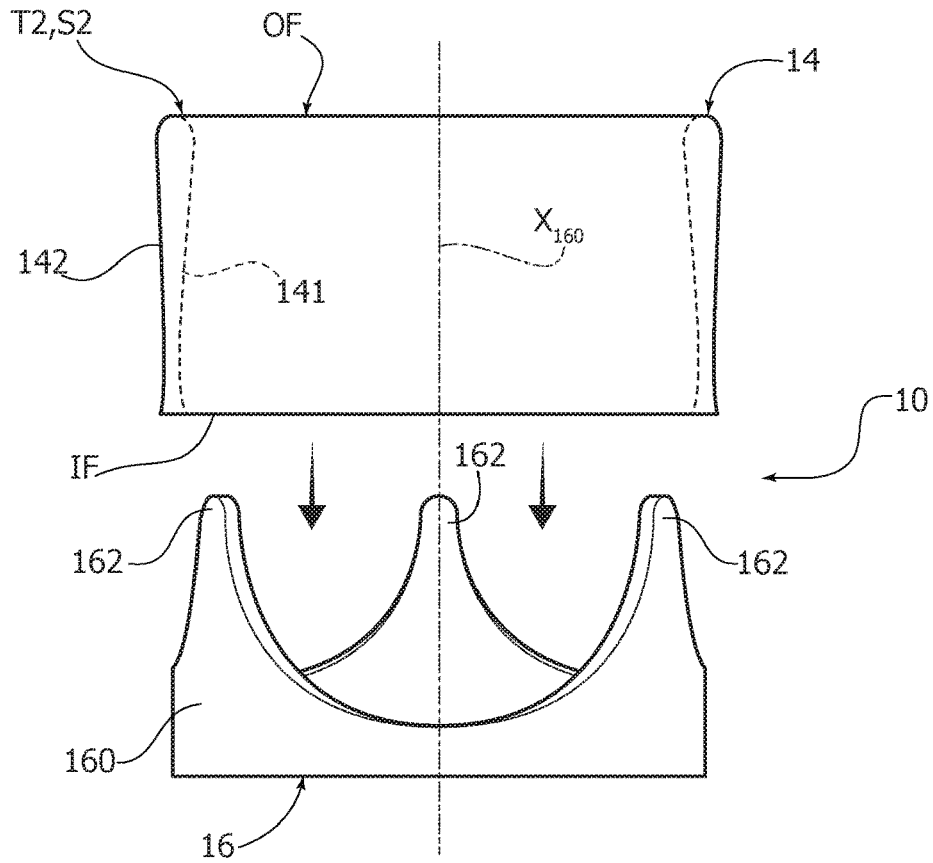

FIG. 12

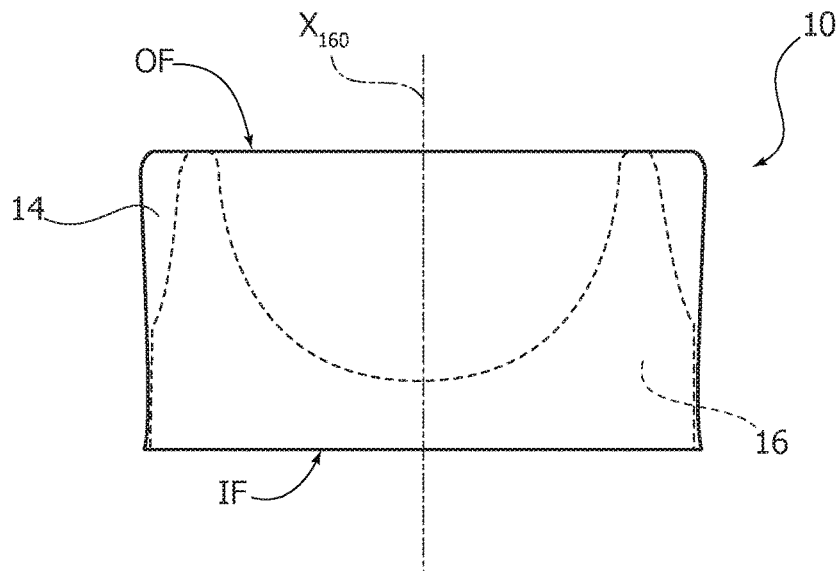

FIG. 13

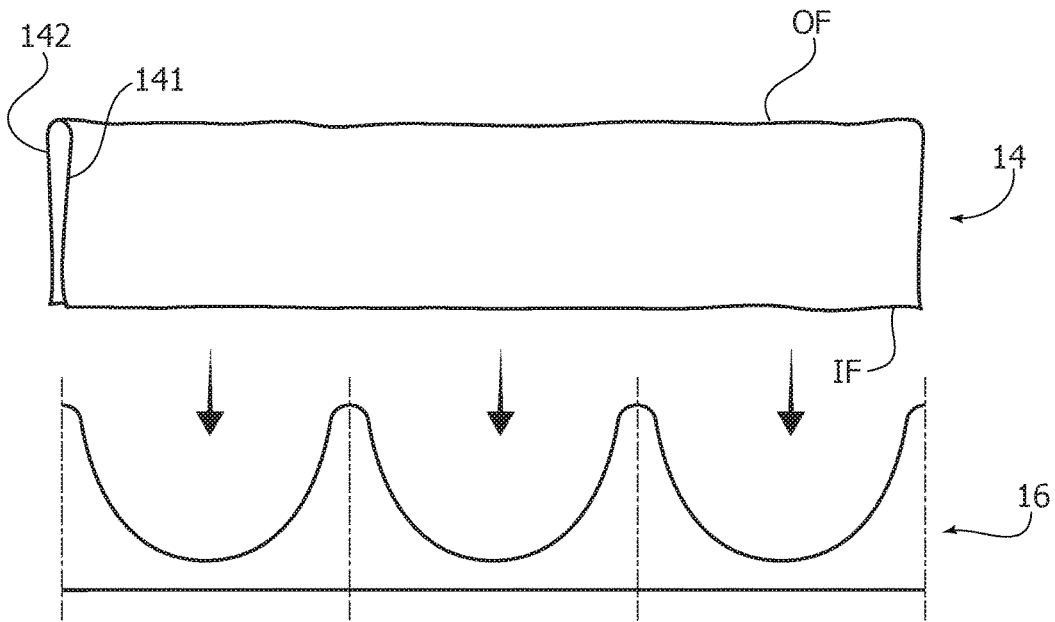

FIG. 14

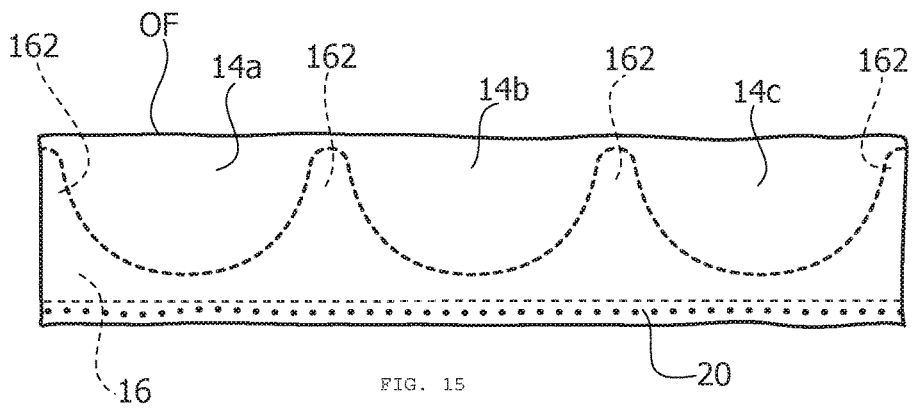

FIG. 15

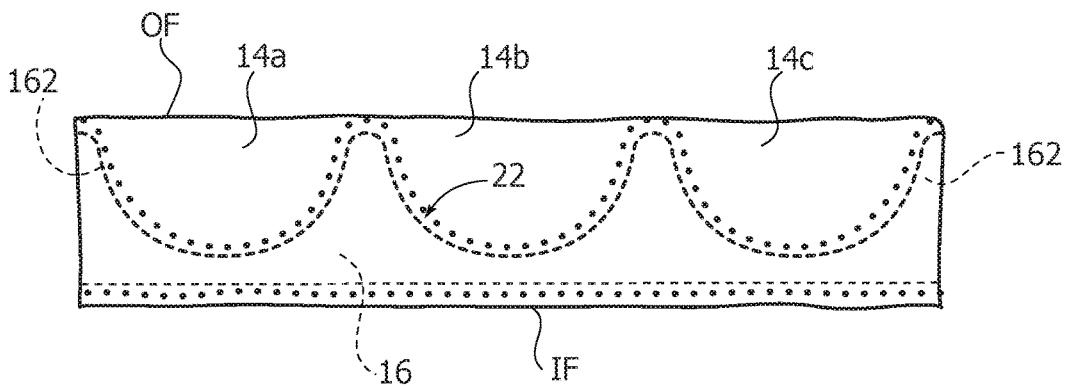
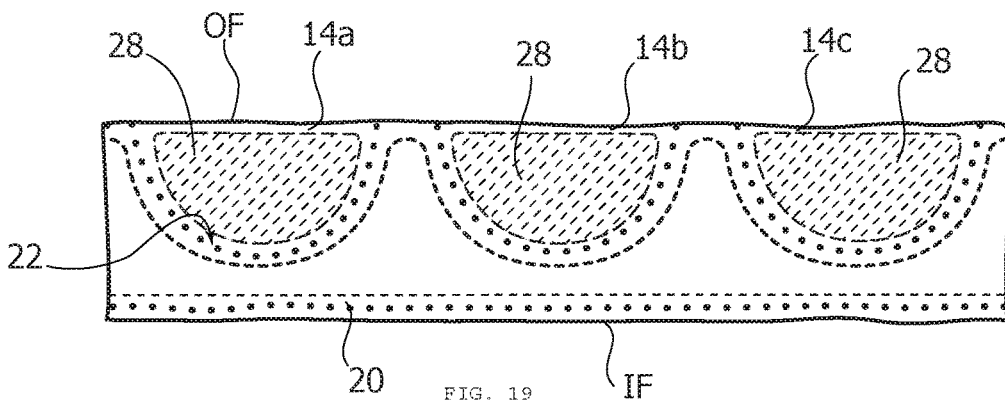
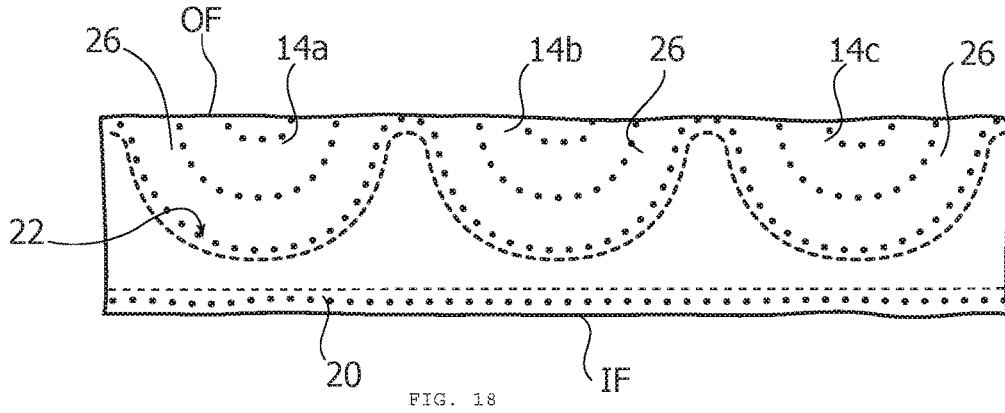
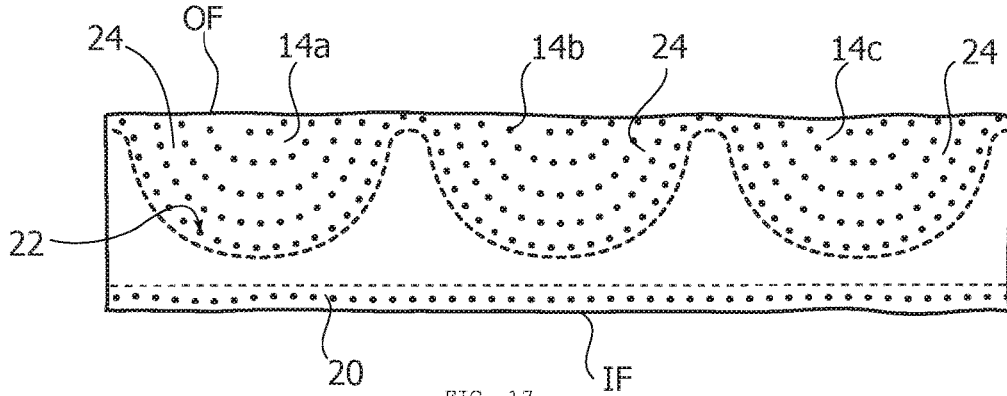

FIG. 16





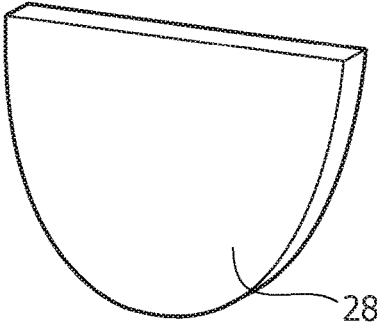

FIG. 20a

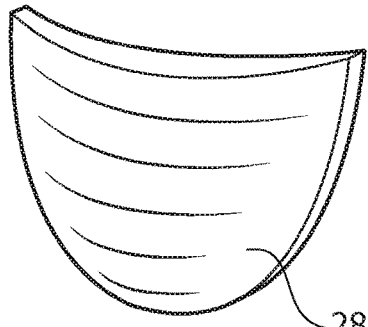

FIG. 20b

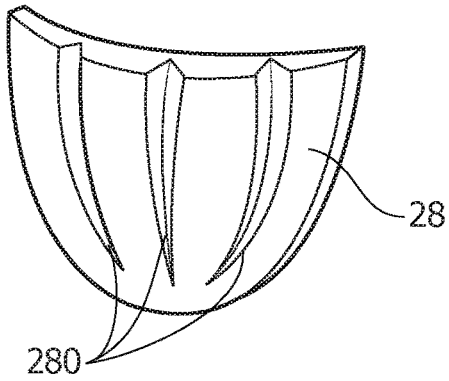

FIG. 20c

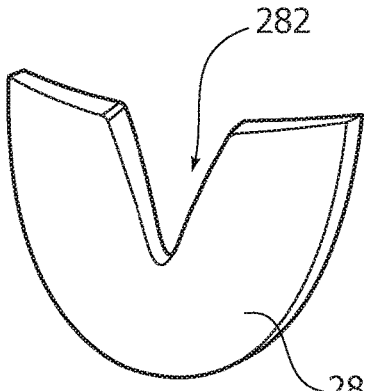

FIG. 20d

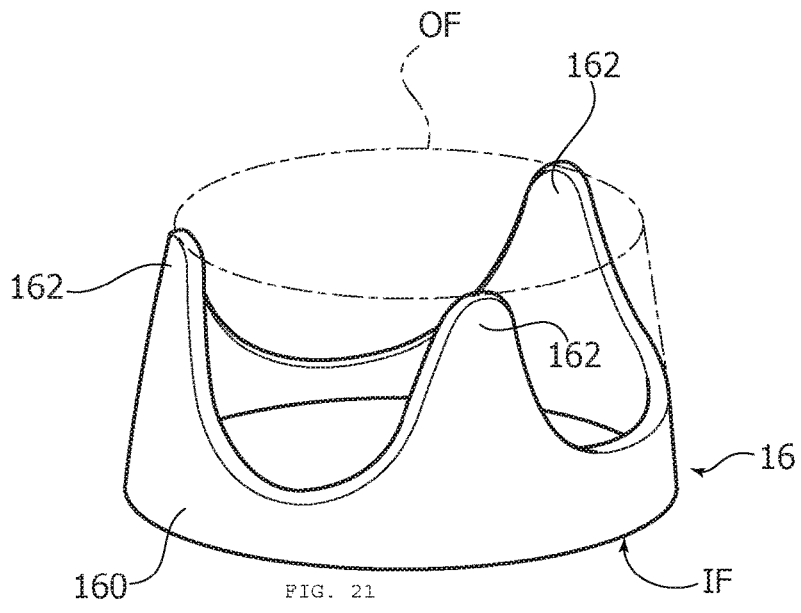

FIG. 21

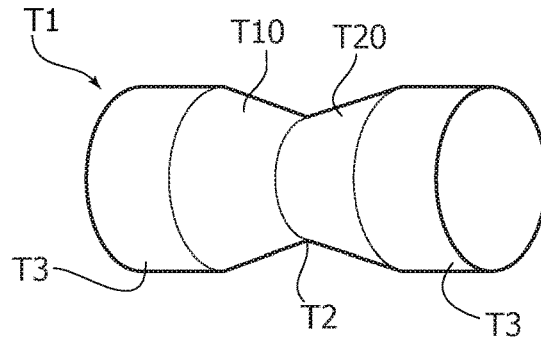

FIG. 22

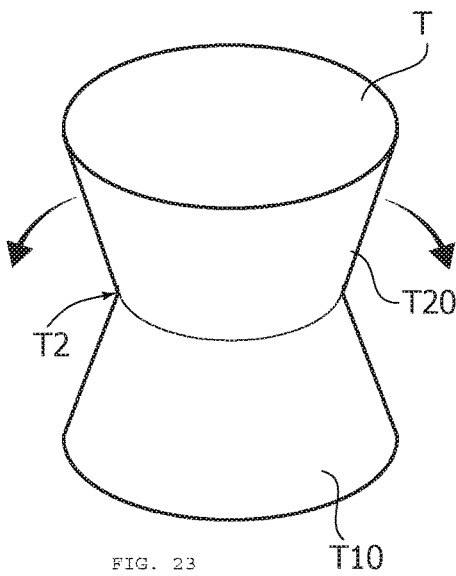

FIG. 23

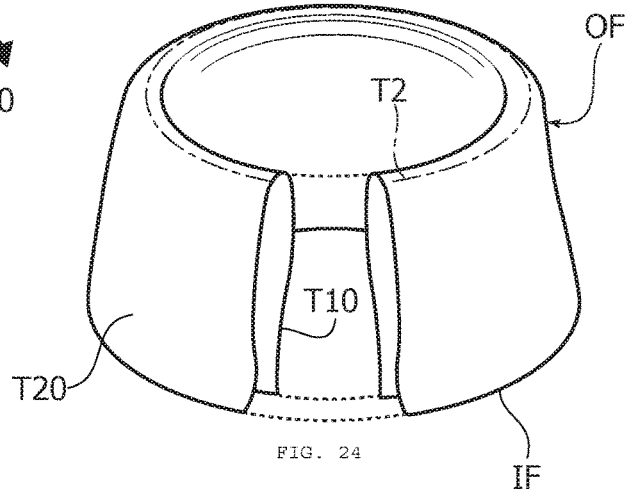

FIG. 24

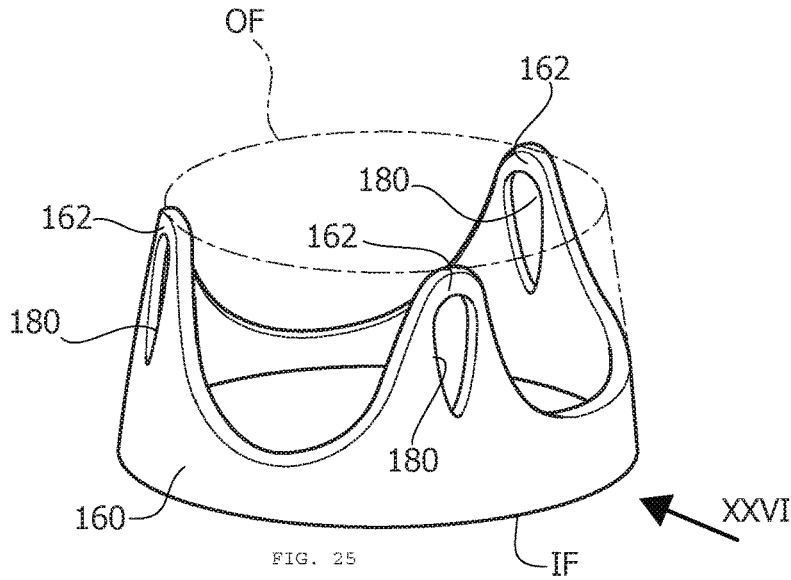

FIG. 25

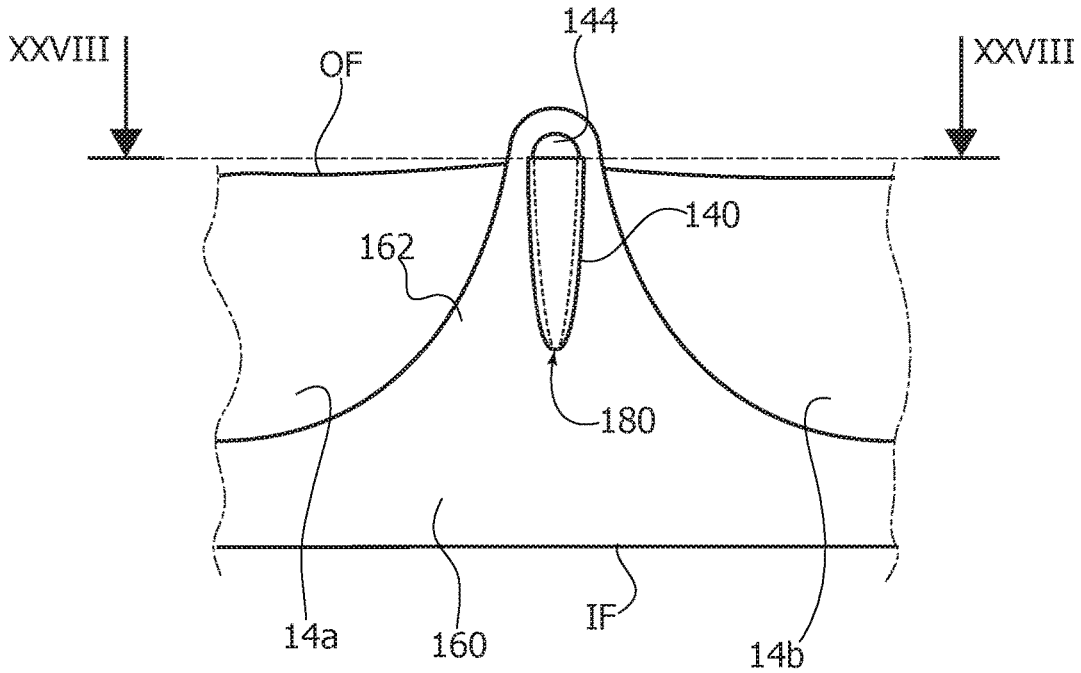

FIG. 26

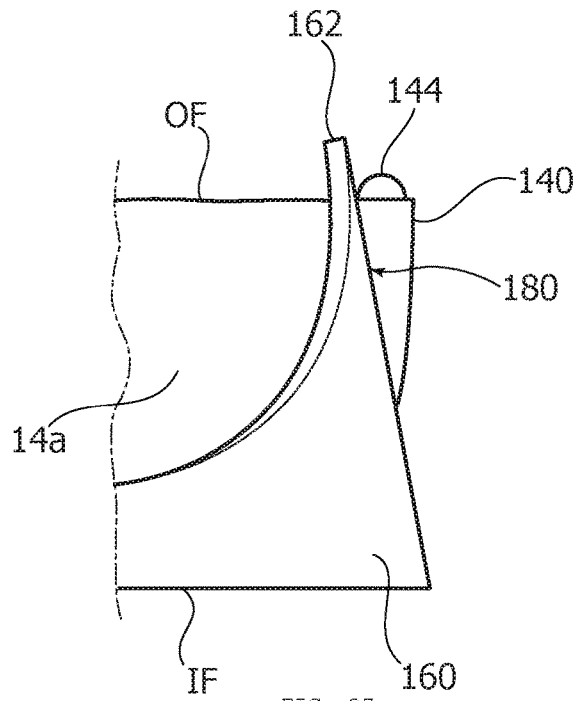

FIG. 27

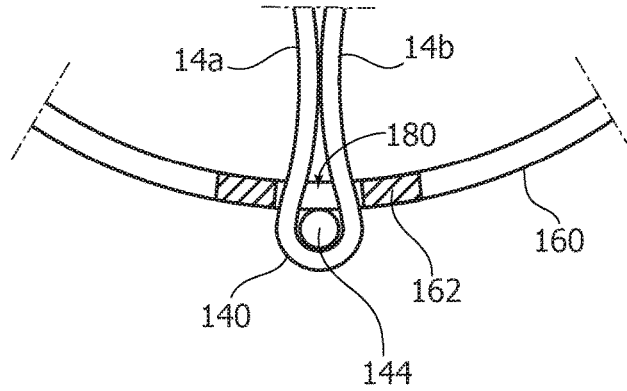

FIG. 28

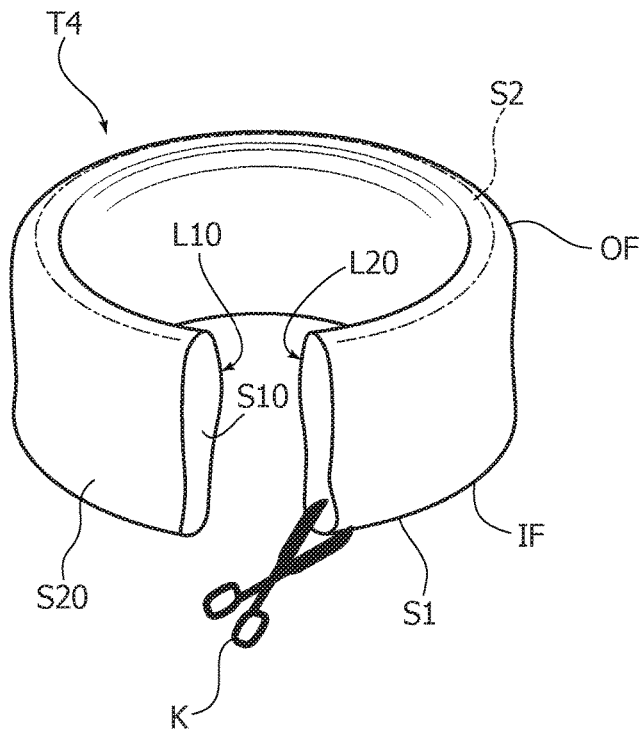

FIG. 29

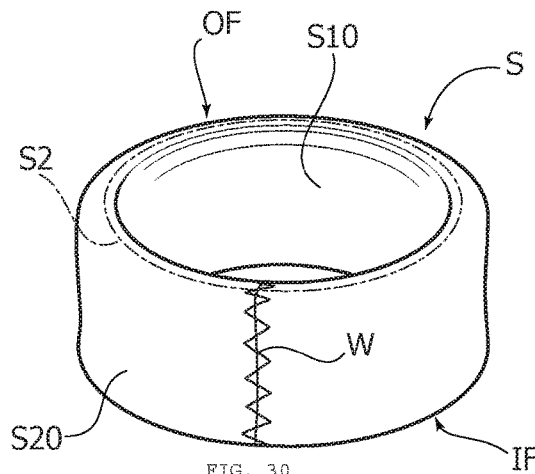

FIG. 30

## VALVULAR SLEEVE FOR VALVULAR PROSTHESES AND CORRESPONDING DEVICE

### CROSS-REFERENCE TO RELATED APPLICATION

[0001] This application is a national stage application of PCT/IB2016/054281, filed Jul. 19, 2016, which claims priority to Italian application 102015000037126, filed Jul. 22, 2015, both of which are herein incorporated by reference in their entirety.

### TECHNICAL FIELD

[0002] The description relates to valvular prostheses.  
[0003] One or more embodiments may apply to valvular prostheses, such as valvular heart prostheses.

### BACKGROUND

[0004] Valvular prostheses are an effective means of treating various pathologies, such as e.g. cardiac valve pathologies, and providing a higher life expectancy and less morbidity in those patients receiving an implanted prosthesis.  
[0005] An increasing demand thus exists for valvular prostheses which may be produced with a cost-effective manufacturing process.

### SUMMARY

[0006] An object of one or more embodiments is to meet such a demand.  
[0007] One or more embodiments may relate to a corresponding prosthetic valvular device, including e.g. a valvular sleeve coupled with a stent.  
[0008] The claims are an integral part of the disclosure of embodiments as provided herein.

### BRIEF DESCRIPTION OF THE DRAWINGS

[0009] One or more embodiments will now be described, by way of example only, with reference to the annexed figures, in which:  
[0010] FIGS. 1 and 2 are exemplary representations of prosthetic valvular devices;  
[0011] FIGS. 3 and 4 are exemplary representations of stents for prosthetic valvular devices;  
[0012] FIGS. 5A, 5B, 6 and 7 are exemplary of the production of valvular sleeves for valvular prostheses according to one or more embodiments;  
[0013] FIGS. 8 to 11 are exemplary of the production of valvular sleeves for valvular prostheses according to one or more embodiments;  
[0014] FIGS. 12 and 13 are exemplary of coupling a valvular sleeve of one or more embodiments with a stent;  
[0015] FIGS. 14 to 18 are further exemplary of coupling a valvular sleeve of one or more embodiments with a stent;  
[0016] FIGS. 19 and 20a to 20d are exemplary of the possible use of pad members in the leaflets of a valvular sleeve of one or more embodiments;  
[0017] FIGS. 21 to 24 are exemplary of the production of tapered valvular sleeves;  
[0018] FIGS. 25 to 28 are exemplary of ways of mounting a valvular sleeve on a stent, with FIG. 26 an enlarged view

of the portion of FIG. 25 indicated by the arrow XXVI and FIG. 28 a cross-sectional view along line XXVIII-XXVIII of FIG. 26; and

[0019] FIGS. 29 and 30 are exemplary of the production of valvular sleeves for valvular prostheses according to one or more embodiments.

[0020] It will be appreciated that, for the sake of clarity, one or more of the figures may not be drawn to a same scale.

### DETAILED DESCRIPTION

[0021] In the ensuing description, one or more specific details are illustrated, aimed at providing an in-depth understanding of examples of embodiments. The embodiments may be obtained without one or more of the specific details, or with other methods, components, materials, etc. In other cases, known structures, materials, or operations are not illustrated or described in detail so that certain aspects of embodiments will not be obscured.

[0022] Reference to “an embodiment” or “one embodiment” in the framework of the present description is intended to indicate that a particular configuration, structure, or characteristic described in relation to the embodiment is comprised in at least one embodiment. Hence, phrases such as “in an embodiment” or “in one embodiment” that may be present in one or more points of the present description do not necessarily refer to one and the same embodiment. Moreover, particular conformations, structures, or characteristics may be combined in any adequate way in one or more embodiments.

[0023] The references used herein are provided merely for convenience and hence do not define the scope of protection or the scope of the embodiments.

[0024] In the figures, reference numeral 10 indicates a valvular prosthesis.

[0025] In one or more embodiments, the prosthesis may be adapted for implantation at a valvular site of a patient. A heart annulus, such as e.g. an aortic annulus, may be exemplary of such an implantation site. A pulmonary valvular annulus may be exemplary of another site for implantation of a valvular heart prosthesis. A mitral valvular annulus may be exemplary of a further site for implantation of such an implantation site.

[0026] The embodiments are not limited to possible use as a heart valvular prosthesis. Other exemplary implantation sites may include, e.g. various sites in the blood circulatory system, both arterial and venous.

[0027] In one or more embodiments, the prosthesis 10 may include a valvular sleeve 14.

[0028] In one or more embodiments, the valvular sleeve 14 may include a tubular body intended to define a flow conduit (e.g. a conduit for the flow of blood) between an inflow end IF and an outflow end OF.

[0029] In one or more embodiments, the valvular sleeve 14 may include one or more (e.g., a plurality) a plurality of valve leaflets. For example, an embodiment having three leaflets, indicated as 14a, 14b and 14c, are shown by way of example in the drawings. The one or more valve leaflets 14a, 14b, 14c may extend from the inflow end IF towards the outflow end OF (that is distally of the inflow end IF) and is displaceable under fluid pressure, e.g. blood pressure:

[0030] radially outwardly to permit fluid flow from the inflow end IF to the outflow end OF of the valvular sleeve 14 (upward direction, in the figures), and

- [0031] radially inwardly to impede or obstruct fluid flow in the opposite direction, namely from the outflow end OF to the inflow end IF of the valvular sleeve **14** (downward direction, in the figures).
- [0032] In one or more embodiments, the valvular sleeve **14** may reproduce operation of a natural valve, e.g. with the leaflets **14a**, **14b**, **14c** adapted to deform:
- [0033] to an inward coapting condition to impede fluid (e.g. blood) flow from the outflow end OF to the inflow end IF, and
- [0034] to an outward expanded condition to permit fluid (e.g. blood) flow from the inflow end IF towards the outflow end OF.
- [0035] It will be appreciated that the designations “inflow end” and “outflow end” refer to the direction of unimpeded fluid flow through the valve prosthesis **10**.
- [0036] In one or more embodiments, the valvular sleeve **14** may be coupled with a supporting armature **16**, currently referred to as “stent”, which is intended to support the (generally flexible) valvular sleeve **14**.
- [0037] FIGS. **3** and **4** are exemplary of stents **16** adapted for use with valvular sleeves **14** including three leaflets **14a**, **14b**, **14c**.
- [0038] Stents **16** as exemplified in FIGS. **3** and **4** may be (substantially) rigid or flexible. Stent materials may include metals (e.g. titanium, cobalt-chrome alloys, Nitinol) or polymers (e.g. Polyoxymethylene (POM) such as Delrin® or polycarbonate).
- [0039] Stent configurations may vary depending on the material of the stent. It will be appreciated that a wide variety of biocompatible materials may be incorporated into stents **16**.
- [0040] For instance, FIG. **3** is exemplary of a solid (e.g. non-apertured) structure which may be adapted for use for e.g. a polymer stent.
- [0041] The open (e.g. apertured) configuration of FIG. **4** may be adapted for use e.g. for a metal stent **16**.
- [0042] One or more embodiments may include network-like stent structures, e.g. for valvular prostheses intended to be (e.g. radially) collapsed in view of implantation: EP-A-1 690 515 A1 is exemplary of a valvular prosthesis including such a collapsible stent.
- [0043] In one or more embodiments, coupling a valvular sleeve **14** with a stent **16** may be either with the stent **16** surrounding (e.g., radially outside of) the valvular sleeve **14** as schematically represented in FIG. **1** (and FIGS. **26** to **28**) or with the valvular sleeve **14** surrounding the stent **16** as schematically represented in FIG. **2**. In one or more embodiments, the stent **16** may be at least partly “sandwiched” between two portions of the valvular sleeve **14**, e.g. as better detailed in the following. In a further embodiment, the valvular sleeve **14** may be “sandwiched” between two portions of the stent **16**.
- [0044] In one or more embodiments, the stent **16** may include a ring-like body **160** intended to be located at the inflow end IF of the valvular sleeve **14** and a plurality of posts or prongs **162** extending from the base body **160** in a distal direction from the inflow end IF towards the outflow end OF of the valvular sleeve **14**.
- [0045] In the exemplary configurations of FIGS. **1** to **4**, the stent **16** may include three posts or prongs **162** equally spaced 120° around the circumferential extension of the base body **160**, that is equally angularly spaced around the main axis  $X_{160}$  of the annular body **160** (and the stent **16** as a whole).
- [0046] FIGS. **3** and **4** are exemplary of embodiments wherein the stent **16** includes a proximal (e.g. inflow) edge or rim extending along a circular line centered around a main axis  $X_{160}$  and a distal (e.g. outflow) edge or rim extending along a scalloped line, that is an arched line connecting the distal ends of the prongs **162**.
- [0047] In one or more embodiments, the leaflets **14a**, **14b**, **14c** of the valvular sleeve **14** may have a semi-lunar (half-moon), scoop-like shape so that each leaflet **14a**, **14b**, **14c** in turn includes a proximal, crescent-shaped margin essentially co-extensive with one of the scallops of the stent **16** as well as a distal margin adapted to coapt with the distal margins of the other leaflets when the valvular sleeve is in the “closed” condition, which impedes fluid flow from the outflow end OF towards the inflow end IF.
- [0048] In one or more embodiments (e.g. in so-called “stentless” valvular prostheses) a stent **16** may not be present, thus providing a valvular prosthesis of high flexibility.
- [0049] In one or more embodiments, a valvular prosthesis may include various other elements in addition to the valvular sleeve **14** or the prosthetic valvular device (valvular sleeve **14** plus stent **16**) as considered herein.
- [0050] These other elements may include e.g. a sewing ring R (as exemplified in phantom lines in FIGS. **1** and **2**), one or more sealing skirts, and other structures intended to facilitate delivery and/or implantation of the prosthesis at the implantation site.
- [0051] The concepts and principles outlined in the foregoing are generally known in the art, thus making it unnecessary to provide a more detailed description herein.
- [0052] One or more embodiments may take advantage of the possibility of producing the valvular sleeve **14** of a flexible material which may be in the form of e.g. a planar sheet member or a tubular member as better detailed in the following.
- [0053] Materials adapted to provide a desired degree of flexibility of the valvular sleeve **14** may include e.g.
- [0054] fabrics produced e.g. by knitting, weaving or felting fibers, including “non-woven” materials,
  - [0055] sheet or laminar materials produced e.g. by lamination, molding or dipping.
- [0056] One or more embodiments may employ sheet or laminar material reinforced by fibers, such as e.g. carbon fibers or Kevlar® fibers.
- [0057] Materials adapted for use in one or more embodiments may include e.g.:
- [0058] biocompatible polymers, such e.g. as silicone, polyethylene, polypropylene, polytetrafluoroethylene (PTFE), polyethylene terephthalate (PET) such as Dacron®;
  - [0059] biological materials such as e.g. bovine, porcine or equine pericardium.
- [0060] Materials produced by “tissue-engineering” technologies may represent an option for one or more embodiments.
- [0061] In one or more embodiments, the valvular sleeve **14** may be coated with a biocompatible coating e.g. a carbonaceous biocompatible coating. Such a coating may extend over the whole sleeve or only over part of it e.g. the part exposed to blood flow.

**[0062]** In one or more embodiments, as exemplified in FIGS. 5A, 5B, 6 and 7, such flexible material (e.g. a fabric material) may be formed to a tubular sheet member T.

**[0063]** FIGS. 5A and 5B are schematically representative of such a tubular sheet member T which may be either produced as such (e.g. as a knitted fabric) as schematically shown in FIG. 5A or produced by folding into a tube a sheet member which is then closed along a longitudinal joining line L1 (e.g. by stitching or welding) as schematically shown in FIG. 5B

**[0064]** Tubular sheet members T as schematically represented in FIGS. 5A and 5B may be similar to vascular grafts as currently used e.g. in replacing portions of blood vessels or other types of body lumen.

**[0065]** FIG. 6 is schematically representative of the possibility of “overturning” or everting such a tubular sheet element to obtain a double-walled annular (tubular) member adapted to produce a valvular sleeve 14.

**[0066]** As exemplified in FIGS. 5A and 5B, a tubular sheet member T may be regarded as including two longitudinally adjacent (subsequent) sections T10, T20 with e.g. the second section T20 adapted to be overturned outwardly with respect to the first section T10 as schematically represented in FIG. 6 to produce the tubular body of FIG. 7. There, the section T20 surrounds the section T10, so that the portions T10, T20 form the inner portion and the outer portion, respectively, of a double-walled tubular body as shown in FIG. 7.

**[0067]** An essentially identical result may be obtained with the second section T20 overturned inwardly of the first section T10, so that the section T10 will surround the section T20, with the portions T10, T20 forming then the outer portion and the inner portion, respectively, of the double-walled tubular body of FIG. 7.

**[0068]** In one or more embodiments, the overturning process of FIG. 6 (however performed, inwardly or outwardly) may lead to the two sections T10, T20 lying one inside the other with the line T2 at which overturning has taken place located at one of the ends of the tubular body shown in FIG. 7.

**[0069]** In one or more embodiments, the two sections T10, T20, i.e. the inner and outer portions of the tubular body of FIG. 7, may be of a same length or different lengths. In one or more embodiments these inner and outer sheets may be trimmed to a same length (height) by cutting the portion of the longer sheet protruding with respect to the shorter sheet.

**[0070]** FIGS. 8 to 11 are exemplary of another approach for producing a tubular body essentially as depicted in FIG. 7.

**[0071]** In one or more embodiments as exemplified in FIGS. 8 to 11 such a tubular body may be produced by using (instead of a tubular sheet member T as shown in FIGS. 5A and 5B) a planar sheet member S (e.g. of a rectangular or square shape) which may be U-folded at a folding line S2 as schematically shown in FIG. 9 to produce a U-folded sheet member including two sections S10, S20 facing each other in the U-shape.

**[0072]** Such a U-shaped sheet member as shown in FIG. 9 may then be handled as a sort of band or ribbon and brought to a ring or collar shape as schematically shown in FIG. 10. This shaping into a ring or collar will result in the opposed end edges L10, L20 of the U-shaped sheet member of FIG. 9 being arranged facing each other.

**[0073]** The end edges L10, L20 may then be joined to each other (e.g. via stitching, adhesive, welding, including ultra-

sound welding) along a joining line W to again produce a double-walled tubular body as shown in FIG. 11 including an outer portion and an inner portion corresponding to the portions S10, S20 originally arranged side-to-side of the sheet member S of FIG. 8.

**[0074]** Whether the portion S10 or the portion S20 will constitute the inner or the outer portion of the tubular body of FIG. 11 will depend, e.g. on the direction of shaping into a ring or collar the U-shaped sheet member of FIG. 9 as schematically shown in FIG. 10.

**[0075]** In one or more embodiments, joining the opposed end edges L10, L20 of the U-folded sheet member of FIG. 9 shaped into a ring or collar as shown in FIG. 10 may involve both the inner and outer portions S10, S20. In one or more embodiments such joining may involve only one of these portions (e.g. S10 or S20).

**[0076]** In one or more embodiments, the process as described (however performed, i.e. irrespective of the direction of shaping into a ring or collar of FIG. 10) may lead to the two portions S10, S20 lying one inside the other with the line S2 at which the sheet member of FIG. 8 has been folded located at one of the ends of the tubular body shown in FIG. 11.

**[0077]** Again, in one or more embodiments the two portions S10, S20, i.e. the inner and outer portions of the tubular body of FIG. 11 may be of equal or different widths (orthogonal to the folding line S2). In one or more embodiments, these inner and outer portions may again be trimmed to a same length (height) by cutting the portion of the longer sheet protruding with respect to the shorter sheet.

**[0078]** FIG. 12 is schematically exemplary of fitting a tubular body as exemplified in FIG. 7 or FIG. 11 onto a stent 16 (e.g. a stent as exemplified in FIG. 3) so that the tubular body of FIG. 7 or FIG. 11 may be included as a valvular sleeve 14 in a prosthetic valvular device 10.

**[0079]** In one or more embodiments, such a valvular sleeve 14 for valvular prostheses may include a tubular body (e.g. as shown in FIGS. 7 and 11) extending between an inflow end IF and an outflow end OF of the valvular sleeve 14, with such a tubular body including an inner portion 141 and an outer portion 142. As used herein, “inner” and “outer” refer to the radial direction of the sleeve 14, e.g. with the outer portion 142 surrounding (e.g. radially outside of) the inner portion 141.

**[0080]** In one or more embodiments:

**[0081]** the inner portion 141 may include e.g. the first section T10 (resp. the second section T20) of the tubular sheet member T or the first portion S10 (resp. the second portion S20) of the sheet member S,

**[0082]** the outer portion 142 may include e.g. the second section T20 (resp. the first section T10) of the tubular sheet member T or the second portion S20 (resp. the first portion S10) of the sheet member S.

**[0083]** Whatever the specific arrangement, a tubular body as per FIG. 7 or FIG. 11 may be fitted onto a stent 16 in such a way that the overturning line T2 or the folding line S2 may be located at the outflow end OF of the valvular sleeve 14.

**[0084]** In that way (see e.g. FIGS. 12 and 13) the overturning line T2 or the folding line S2 may be located at the distal margins of the leaflets 14a, 14b, 14c, that is—as indicated previously—at the margins adapted to coapt when the valvular sleeve is in the closed position which impedes fluid flow from the outflow end OF towards the inflow end IF.

[0085] Due to the inner and outer portions **141**, **142** being formed by overturning/folding a sheet-like member (possibly formed into a tube) the inner portion **141** and outer portion **142** will be formed out of a single sheet member having a loop or fold extending around the outflow end OF between the inner and outer portions **141**, **142**. The inner and outer portions **141**, **142** are parts of a same laminar (sheet-like) body e.g. of a fabric material or the like, with a loop or fold at the overturning line T2/folding line S2 located at (e.g. extending around) the outflow end OF of the sleeve **14**.

[0086] In one or more embodiments, by using a single sheet of material overturned or folded upon itself, the inner and outer portions **141**, **142** will not require to be joined at the outflow end OF of the sleeve **14** by resorting to e.g. stitching, gluing, welding and so on, as required if two separate sheets were joined at the outflow end OF of the sleeve **14**.

[0087] In one or more embodiments, the two portions **141**, **142** being already connected at the overturning line T1 or the folding line S2 “originally”, e.g. due to being formed as one piece of fabric or other laminar material, will avoid any sort of cutting (followed by stitching, gluing, welding and so on) as possibly needed to connect two separate portions **141** and **142**. In one or more embodiments, the drawbacks possibly related e.g. to fibres of a fabric cut becoming loose, sharp edges or protrusions formed by cutting, stitching, gluing, welding may thus be avoided.

[0088] FIG. **12** is exemplary of a way of coupling the valvular sleeve **14** to a stent **16** by taking advantage of the valvular sleeve **14** being a double-walled structure including an inner portion **141** and an outer portion **142** with a loop or fold therebetween.

[0089] In one or more embodiments the valvular sleeve **14** may be vested onto the stent **16** as schematically shown in FIG. **13**, e.g. by simply letting the stent **16** extend in the (inverted) U-shape or channel shape of the structure of the valvular sleeve **14**.

[0090] In that way, the valvular sleeve **14** may be retained onto the stent **16** against any force urging the valvular sleeve **14** in the proximal direction (outflow to inflow, e.g. downward in FIG. **13**) without any other form of coupling (e.g. stitching, and so on) being required for that purpose. Such a sort of a form coupling may facilitate the action of the prosthetic valvular device **10** in impeding undesired proximal flow (e.g. of blood) from the outflow end OF towards the inflow end IF.

[0091] As noted previously e.g. in connection with FIGS. **12** and **13**, in one or more embodiments the overturning line T2 or the folding line S2 may be located at the distal margins of the (double-walled) leaflets **14a**, **14b**, **14c**.

[0092] Various types of coupling of the valvular sleeve **14** to the stent **16** may be otherwise envisaged e.g. as exemplified in the following.

[0093] Also, while possible coupling of the valvular sleeve **14** to a stent **16** to form a prosthetic valvular device has been exemplified here, the valvular sleeve **14** may be included in a “stentless” valvular prosthesis without being coupled to a stent.

[0094] Also, coupling with a stent **16** has been exemplified in FIGS. **12** and **13** with the stent **16** extending between the inner sheet **141** and the outer sheet **142** of the valvular sleeve **14**. Other embodiments as exemplified in FIGS. **1** and **2** may provide for a stent **16** being configured either for surround-

ing the valvular sleeve **14** (e.g. as better detailed in the following) or for being surrounded by the valvular sleeve **14**.

[0095] Whatever the embodiments (e.g. a “stentless” arrangement or a “stented” arrangement involving coupling with a stent **16**, with the stent **16** arranged inside, outside or inserted between the inner and outer portions **141**, **142** of the valvular sleeve **14**), the (double-walled) leaflet portions **14a**, **14b**, **14c** may be shaped to a desired semi-lunar (e.g. eyelid-shaped) scoop-like form as exemplified e.g. in FIGS. **1** and **2** with such shape retained in the absence of any fluid force applied thereto. This may be the condition in which the valvular sleeve **14** may be stored e.g. mounted in a holder in a container or in an implantation kit to be made available at the implantation theatre.

[0096] Such shaping of the leaflets may be by known means including e.g. mechanical shaping, liquid pressure, application of heat or combinations of these. The nature of the sheet material (e.g. fabric or tissue) of the valvular sleeve **14** may dictate or limit available options for the technique(s) adopted for shaping the leaflets.

[0097] FIG. **14** reproduces for the sake of simplicity the same situation as depicted in FIG. **12** (namely the possible coupling of the valvular sleeve **14** with a stent **16**). In FIG. **14** the valvular sleeve **14** and the stent **16** are shown in a notional expanded circumferential view, that is in a notional deployed plane view, as would result by cutting the substantially cylindrical shape of the prosthetic device **10** along one of its generating lines and letting the device **10** lie flat on a plane.

[0098] FIGS. **15** to **18** are exemplary of various embodiments where the inner and outer portions **141**, **142** of the valvular sleeve **10** may be joined at various points, e.g. via stitching, adhesive, welding, including ultrasound welding. While most of the examples illustrated in FIGS. **15** to **18** (and FIGS. **20** to **28**) refer to a prosthetic valvular device including a valvular sleeve **14** coupled with a stent **16**, the relative disclosure will identically apply to a “stentless” valvular sleeve **14**, that is a valvular sleeve **14** intended to be used in a valvular prosthesis without coupling with a stent **16**.

[0099] FIG. **15** exemplifies the possibility of joining (e.g. by stitching, adhesive, welding including ultrasound welding; hereinafter all these exemplary possibilities will be referred simply as “joining”) the inner and outer portions **141**, **142** with a continuous or discontinuous, e.g. point-wise, joining line **20** extending along the inflow end IF of the valvular sleeve **14**.

[0100] In that way, the inner and outer portions **141**, **142** formed of a single piece of sheet material with a loop therebetween at the outflow end OF (that is, at the distal margins of the leaflets **14a**, **14b**, **14c**) will also be joined—by a positive seam as represented the joining line **20**—at the inflow end IF so that the double-walled structure of the valvular sleeve **14** may be closed (also) at the inflow end IF.

[0101] A joining line **20** as exemplified in FIG. **15** may join the inner portion **141** and the outer portion **142** by extending longitudinally or axially outwardly of the stent **16** (if present), such that the stent is not located between the inner portion **141** and outer portion **142** of the sleeve **14**. Alternatively, the joining line **20** may extend to the stent **16**, e.g. in the form of stitches extending through apertures (e.g. holes) in the stent **16**. In this embodiment, all or portions of the stent may be located or “sandwiched” between the inner and outer portions **141**, **142**.



[0102] FIG. 16 is exemplary of the possibility of providing a joining line 22 (again adapted to be produced with any of the exemplary joining techniques considered in the foregoing) extending along a scalloped trajectory more or less closely following the crescent-shaped proximal margins of the leaflet portions of the inner and outer sheets 141, 142: these leaflet portions of the portions 141 and 142 of the tubular body of the sleeve are indicated with the same references 14a, 14b, 14c used for the valve leaflets as shown e.g. in FIGS. 1 and 2.

[0103] FIG. 16 shows that the joining line 22 may extend arcuately between the prongs 162 of the stent thus forming the so-called “commissures” of the valvular sleeve 14. In some embodiments, both joining line 20 (FIG. 15) and joining line 22 (FIG. 16) are used to capture the stent 16 between a portion of the inner and outer portions 141, 142 of valvular sleeve 14.

[0104] FIGS. 17 and 18 are exemplary of the possibility of forming joining lines 24 and 26 to join the inner and outer portions 141, 142 within their leaflet portions 14a, 14b, 14c. In each Figure, a series of concentric arcuate joining lines, comprising progressively smaller arcuate lengths, is provided from the proximal leaflet margins adjacent to the stent 16 to an outermost arcuate length near distal leaflet margins (i.e., the margins that coapt to impede fluid flow from the outflow end OF to the inflow end IF). It will be appreciated that other joining lines (e.g., parallel, perpendicular, or otherwise angled with respect to the axis  $X_{160}$  of the valve, may be used in alternative embodiments.

[0105] By resorting to such an arrangement, the leaflets (which are double-walled due to the presence of the inner portion 141 and the outer portion 142) will behave in fact as a single (layered) laminar body e.g. avoiding the formation of pockets between the inner and outer portions 141, 142.

[0106] Also, the joining lines 24, 26 may be beneficial in facilitating bestowing onto the leaflet portions 14a, 14b, 14c their concave scoop-like configuration as exemplified in FIGS. 1 and 2 and/or in facilitating retention of such a configuration as possibly imparted with other means as discussed previously.

[0107] The pattern of the joining lines 24, 26 (which may be either continuous or discontinuous, e.g. point-wise as exemplified in FIGS. 17 and 18) may facilitate achieving/retaining a certain shape and may include e.g. radial lines with respect to the half-moon shape of the leaflets 14a, 14b, 14c as shown in FIG. 17 or extend along scalloped trajectories somewhat reproducing the scalloped trajectory of the joining line 22 at the proximal margins of the leaflets 14a, 14b, 14c.

[0108] FIG. 19 is exemplary of the possibility of including pad members 28 in the space between the inner wall portion 141 and the outer wall portion 142 at the leaflet portions 14a, 14b, 14c.

[0109] In one or more embodiments, such pad members 28 may be generally crescent-shaped, semi-circular, semi-elliptical or eyelid-shaped (e.g. in the form of a shield), and may be scored or have notches cut in portions thereof, as schematically represented in parts a), b), c) and d) of FIG. 20. The pad members 28 may be planar or nearly planar, or may comprise a curved surface comprising a portion of a three-dimensional spherical body or a shape derived therefrom, as illustrated in parts b), c) and d) of FIG. 20. In one or more embodiments, the pad members 28 may include a flexible material.

[0110] In one or more embodiments, the pad members 28 may include a spongy material.

[0111] In one or more embodiments, the pad members 28 may have a surface sculpturing as exemplified at 280 in part c) of FIG. 20. This may facilitate following the rhythmic deformation that the leaflets 14a, 14b, 14c undergo (e.g. under pulsating blood pressure) in operation.

[0112] In one or more embodiments, the pad members 28 may include e.g. at their distal rim, at least one notch 282 which may bestow on the pad member an overall V or U shape. The notch or notches 282 may facilitate the closing and opening movement of the corresponding leaflet, that is the movement of the leaflet portions under fluid pressure between an inward condition to impede fluid flow from the outflow end OF to the inflow end IF and an outward condition to permit fluid flow from the inflow end IF to the outflow end OF.

[0113] In one or more embodiments, the pad members 28 may be retained at their location and prevented from being dislodged distally of the valvular sleeve 14 by the loop or fold between the inner portion 141 and the outer portion 142 at the outflow end OF of the valvular sleeve 14.

[0114] In one or more embodiments, the joining lines 24, 26 and/or the pad members 28 (possibly provided with the sculpturing 280 and/or the notch(es) 282) may be functional in bestowing onto the leaflets 14a, 14b, 14c a “bi-stable” behaviour thus making the leaflets 14a, 14b, 14c capable of alternatively “snapping open” under inflow-to-outflow fluid (e.g. blood) pressure and “snapping closed” under reversed outflow-to-inflow fluid pressure.

[0115] The valvular sleeve 14 as exemplified herein may include a plurality of (e.g., three) double-walled valve leaflets 14a, 14b, 14c (with the stent 16, if present, including a matching plurality (e.g., three) prongs 162) equally extending angularly 120° around the main axis  $X_{160}$ .

[0116] One or more embodiments may include a different number of leaflets and/or leaflets of different sizes. For instance, embodiments for use e.g. in venous valves may include two leaflets or even just one leaflet. Valvular sleeves for implantation at, e.g., a mitral site may include a higher number of leaflets e.g. four leaflets, possibly of different sizes.

[0117] One or more embodiments are largely independent of the number and sizes of the leaflets in the valvular sleeve 14.

[0118] FIGS. 21 to 28 are exemplary of possible embodiments wherein a valvular sleeve 14 may have a tapered shape from a (larger) inflow end IF towards a (narrower) outflow end OF. Such a tapered configuration may be regarded as more closely reproducing the anatomy of certain natural valves intended to be replaced with a valve prosthesis.

[0119] As shown in FIG. 21, a stent (if contemplated) for such a valvular prosthesis may include prongs (posts) 162 which extend from a base body 160 in a distal direction from the inflow end IF to the outflow end OF with a general taper causing the distal ends of the prongs 162 to lie on an outflow circumference (as schematically indicated in chain line OF of FIG. 21) which has a smaller radius than the inflow end IF.

[0120] FIGS. 22 to 24 are exemplary of one or more embodiments which may permit to produce a double-walled tubular body essentially similar to the tubular body as shown in FIG. 7. While still including sections T10, T20 adapted to

form the inner portion **141** and the outer portion **142** (or vice versa) of the valvular sleeve **14** as discussed in the foregoing, the tubular body of FIG. **24** will exhibit an overall tapered (e.g. frusto-conical) shape.

[0121] The embodiment of FIGS. **22** to **24** is essentially similar (also as regards the possibility for the sections **T10**, **T20** to exchange their roles in forming the inner and the outer portions **141**, **142**) to the embodiment of FIGS. **5A**, **5B**, **6** and **7**. The related detailed description will not be repeated here for the sake of brevity, while noting that, in the case of FIGS. **22** to **24**, the tubular sheet member **T** may be an hourglass-shaped tube with an overturning (folding) line **T2** arranged at the waist line of the hourglass shape.

[0122] Such an hourglass-shaped tubular member **T** as shown in FIG. **23** may be produced e.g. by means of fabric knitting techniques adapted for use also for medical devices (e.g. vascular grafts). FIGS. **22** and **23** refer to a (non-mandatory) embodiment where the hourglass-shaped tubular sheet member **T** is produced starting from a longer tubular sheet member **T1** (produced e.g. by a knitting process of a known type) including an intermediate hourglass-shaped portion which is isolated by cutting opposed cylindrical ends **T3**.

[0123] The tapered tubular body of FIG. **24** may then be used either in a tapered valvular prosthesis of the stentless type or in a tapered valvular prosthetic device **10** for a stented valvular prosthesis by being coupled with a stent **16** as exemplified in FIG. **21**.

[0124] The related disclosure provided in connection with FIGS. **12** to **20** will thus apply (also) to such a tapered valvular sleeve **14**/valvular prosthetic device **10**.

[0125] FIGS. **25** to **28** exemplify one embodiment of a way of coupling a valvular sleeve **14** with a stent **16** by arranging the stent **16** surrounding the valvular sleeve **14** as schematically represented in FIG. **1**.

[0126] FIGS. **25** to **28** exemplify such embodiments in connection with a tapered valvular sleeve **14**/stent **16**. The same concepts may apply also to a non-tapered valvular sleeve **14**/stent **16** as discussed previously in this description.

[0127] In one or more embodiments as exemplified in FIGS. **25** to **28** the prongs **162** extending distally of the main body **162** from the inflow end **IF** to the outflow end **OF** may include a longitudinal slit or aperture **180** into which a folded portion **140**, formed e.g. at one of the commissures of the valvular sleeve **14**, may be inserted as shown e.g. in FIGS. **26** to **28**.

[0128] In that way, the valvular sleeve **14** will essentially extend within a portion of the stent **16**, that is with the stent **16** largely surrounding the valvular sleeve **14**. However, the folded portions **140**, will at least marginally extend at the outer surface of the stent **16** so that a peg member **144** may be inserted into each folded portion **140** to provide anchoring of the commissures of valvular sleeve **14** to the prongs **162**.

[0129] That mounting arrangement may be applied also in the case on non-tapered (e.g. cylindrical) valvular sleeves **14**/stents **16**.

[0130] In one or more embodiments (related to a tapered valvular prosthesis **10** as exemplified in FIGS. **25** to **28**) the slits or apertures **180** may be provided with an increasing width (e.g. with a sort of “raindrop” shape) in the distal direction of the stent **16**, namely with a width increasing away from the body portion **160**.

[0131] The peg members **144** may be inserted wedge-like into the folded portions **140** in such a way that the folded portions **140** will be widening towards the outflow end **OF** of the valvular sleeve. The circumferential extension, and thus the radial size of the valvular sleeve **14** within the stent **16** will thus be smaller at the outflow end **OF** in comparison with the inflow end **IF**: this is because the folded portions **140** will “draw” more material of the valvular sleeve **14** out of the stent **16** at the outflow end **OF** than at the inflow end **IF**. The “effective” valvular sleeve **14** surrounded by the stent **16** will then have a tapered shape as in the case of the tapered tubular body of FIG. **24**.

[0132] FIGS. **29** and **30** are exemplary of still another way of producing a tubular body as exemplified e.g. in FIG. **11** for use in any of the embodiments exemplified herein.

[0133] In FIGS. **29** and **30** a tubular sheet member **T4** may again be used. Instead of being overturned at an overturn line **T2** as exemplified in FIG. **6**, the tubular member **T4**, possibly flattened to a general ribbon-like shape, may be formed into a ring or collar as schematically shown in FIG. **29**, thus undergoing the same type of shaping as discussed in connection with FIG. **10**. Once formed into a ring or collar, the tubular member **T4** will have opposed ends, again designated **L10**, **L20**, which may be joined to each other at a joining line **W** to form a tubular body adapted for use as a valvular sleeve **14** as disclosed in the foregoing.

[0134] Once formed into a ring or collar, the tubular member **T4** will in fact have two opposed loop portions designated **S2** and **S1** in FIG. **29**. One of these loop portions at the sides of the flattened tubular member **T4** shaped into a ring or collar may in fact correspond to a folding line **S2** forming a loop between the two wall portions of the ribbon-like tubular member. Such a folding line **S2** may again be located at the outflow end **OF** of the tubular sleeve **14** as exemplified previously in connection with FIGS. **10** to **13**.

[0135] As exemplified by a scissor **K** in FIG. **29**, the loop portion **S1** may be cut in order to open the tubular body at the end opposed the folding line **S2** as in the case of the tubular body of FIG. **11**. This will permit insertion of a stent **16** into the valvular sleeve as schematically shown in FIGS. **12** and **14**.

[0136] In one or more embodiments, the opposed walls **S10** and **S20** of the tubular member **T4** may be left connected at both lines **S2** and **S1**. This may apply e.g. to “stentless” valvular prostheses for which coupling to a support stent **16** may not be envisaged or to those embodiments where coupling with a stent **16** may occur either by causing the stent **16** to surround the valvular sleeve **14** (see e.g. FIG. **1**) or by causing the valvular sleeve **14** to surround the stent **16**, so that the space between the inner portion **141** and the outer portion **142** may not need to be made open for permitting insertion of a stent **16** therein.

[0137] For instance, an arrangement wherein the inner and outer portions **141**, **142** of the valvular sleeve **14** have a loop or fold therebetween at both the inflow end **IF** and the outflow end **OF** (that is at the distal margins of the leaflets **14a**, **14b**, **14c**) may be adapted for coupling to a stent using the slit/aperture and peg arrangement as exemplified in FIGS. **25** to **28**.

[0138] In one or more embodiments a double-walled tubular body as exemplified in FIG. **30** may be produced by knitting methods (e.g. by means of circular knitting machines) as a single body, thus dispensing with the need of providing a joining line **W**.

[0139] One or more embodiments may thus include a plurality of (e.g. three) valve leaflet portions extending distally of said inflow end towards distal margins at said outflow end.

[0140] In one or more embodiments, the valve leaflets may be displaceable under fluid pressure to an inward, "closed" condition wherein the distal margins of the leaflets coapt to impede fluid flow from said outflow end to said inflow end.

[0141] In one or more embodiments, the inner and outer portions 141, 142 of the (double-walled) leaflets 14a, 14b, 14c may be formed of a single piece of sheet material with a fold or loop (e.g. the folding line S2) therebetween at the outflow end OF (that is, at the distal margins of the leaflets 14a, 14b, 14c).

[0142] In the following, examples are described to facilitate the understanding of embodiments.

[0143] In some embodiments: A valvular sleeve for valvular prostheses including a tubular body extending between an inflow end and an outflow end, the tubular body including a sheet member folded at said outflow end, whereby the tubular body includes an inner tubular portion and an outer tubular portion surrounding the inner tubular portion.

[0144] In some embodiments: The valvular sleeve of Embodiment 1, wherein said inner and outer portions comprise either of:

[0145] respective subsequent sections of a tubular member overturned at an overturn line at said outflow end;

[0146] respective portions of a sheet member U-folded at a folding line at said outflow end, said U-folded sheet member having opposed end edges joined to each other to form said tubular body.

[0147] In some embodiments: The valvular sleeve of Embodiment 1 or Embodiment 2, wherein said inner and outer portions are joined to each other, optionally by suture, at said inflow end.

[0148] In some embodiments: The valvular sleeve of Embodiment 1, wherein said inner and outer portions comprise respective wall portions of a tubular ribbon-like member, optionally having opposed ends joined to each other to form said tubular body.

[0149] In some embodiments: The valvular sleeve of any of the previous Embodiments, wherein said inner and outer portions include valve leaflet portions extending distally of said inflow end towards said outflow end, said valve leaflet portions displaceable under fluid pressure to an inward condition to impede fluid flow from said outflow end to said inflow end and an outward condition to permit fluid flow from said inflow end to said outflow end.

[0150] In some embodiments: The valvular sleeve of Embodiment 5, wherein said inner and outer portions are joined to each other, preferably by suture, at said valve leaflet portions.

[0151] In some embodiments: The valvular sleeve of Embodiment 6, wherein said inner and outer portions are joined to each other at said valve leaflet portions by at least one of:

[0152] a scalloped joining line extending at a proximal edge of said leaflet portions,

[0153] a pattern of joining lines extending distally of a proximal edge of said leaflet portions.

[0154] In some embodiments: The valvular sleeve of any of Embodiments 5 to 7, including a pad member set between said inner and outer sheets at said valve leaflet portions.

[0155] In some embodiments: The valvular sleeve of any of the previous Embodiments, wherein said inner and outer portions comprise respective subsequent sections of an hourglass-shaped tubular sheet member overturned at an overturn line at the waistline of the hourglass shape, said overturn line being at said outflow end of the valvular sleeve, whereby said valvular sleeve has a tapered shape from said inflow end towards said outflow end.

[0156] In some embodiments: A prosthetic valvular device including:

[0157] a valvular sleeve according to any of Embodiments 1 to 9,

[0158] a stent supporting said valvular sleeve.

[0159] In some embodiments: The prosthetic valvular device of Embodiment 10, including anchoring formations, optionally suture formations, anchoring said valvular sleeve to said stent.

[0160] In some embodiments: The prosthetic valvular device of Embodiment 10 or Embodiment 11, wherein said stent extends between said inner and outer portions of the valvular sleeve.

[0161] In some embodiments: The prosthetic valvular device of Embodiment 10 or Embodiment 11, wherein:

[0162] said stent is arranged surrounding said valvular sleeve and includes a ring-like body at said inflow end of the valvular sleeve with a plurality of prongs extending from said ring-like body in a distal direction from said inflow end towards said outflow end of the valvular sleeve,

[0163] said prongs have a longitudinal slit,

[0164] said valvular sleeve includes folded portions which extend through the longitudinal slits of said prongs externally of said stent, and

[0165] peg members are inserted into said folded portions of the valvular sleeve externally of said stent to provide anchoring of said valvular sleeve to the stent.

[0166] In some embodiments: The prosthetic valvular device of Embodiment 13, wherein:

[0167] said prongs extend distally of said ring-like body from said inflow end towards said outflow end of the valvular sleeve with a tapered shape of said stent,

[0168] said prongs have a longitudinal slit having an increasing width in said distal direction, and

[0169] said peg members are inserted wedge-like into said folded portions of the valvular sleeve to provide anchoring of said valvular sleeve to the stent, wherein the valvular sleeve is radially larger at said inflow end than at said outflow end.

[0170] In some embodiments: The prosthetic valvular device of any of embodiments 10 to 14, wherein said stent is collapsible.

[0171] Without prejudice to the underlying principles, the details and embodiments may vary, even significantly, with respect to what has been described by way of the example only, without departing from the extent of protection.

[0172] The extent of protection is defined by the annexed claims.

1-15. (canceled)

16. A valvular sleeve for valvular prostheses including a tubular body extending between an inflow end and an outflow end, the tubular body including a sheet member

folded at said outflow end, whereby the tubular body includes an inner tubular portion and an outer tubular portion surrounding the inner tubular portion.

**17.** The valvular sleeve of claim **16**, wherein said inner and outer portions comprise at least one of:

respective subsequent sections of a tubular member overturned at an overturn line at said outflow end; and  
respective portions of a sheet member U-folded at a folding line at said outflow end, said U-folded sheet member having opposed end edges joined to each other to form said tubular body.

**18.** The valvular sleeve of claim **16**, wherein said inner and outer portions are joined to each other at said inflow end.

**19.** The valvular sleeve of claim **16**, wherein said inner and outer portions comprise respective wall portions of a tubular ribbon-like member.

**20.** The valvular sleeve of claim **16**, wherein said inner and outer portions include valve leaflet portions extending distally of said inflow end towards said outflow end, said valve leaflet portions displaceable under fluid pressure to an inward condition to impede fluid flow from said outflow end to said inflow end and an outward condition to permit fluid flow from said inflow end to said outflow end.

**21.** The valvular sleeve of claim **20**, wherein said inner and outer portions are joined to each other at said valve leaflet portions.

**22.** The valvular sleeve of claim **21**, wherein said inner and outer portions are joined to each other at said valve leaflet portions by at least one of:

a scalloped joining line extending at a proximal edge of said leaflet portions, and  
a pattern of joining lines extending distally of a proximal edge of said leaflet portions.

**23.** The valvular sleeve of claim **20**, including a pad member set between said inner and outer sheets at said valve leaflet portions.

**24.** The valvular sleeve of claim **16**, wherein said inner and outer portions comprise respective subsequent sections of an hourglass-shaped tubular sheet member overturned at an overturn line at the waistline of the hourglass shape, said

overturn line being at said outflow end of the valvular sleeve, whereby said valvular sleeve has a tapered shape from said inflow end towards said outflow end.

**25.** A prosthetic valvular device including a valvular sleeve according to claim **16** and a stent supporting said valvular sleeve.

**26.** The prosthetic valvular device of claim **25**, including anchoring formations, anchoring said valvular sleeve to said stent.

**27.** The prosthetic valvular device of claim **25**, wherein said stent extends between said inner and outer portions of the valvular sleeve.

**28.** The prosthetic valvular device of claim **25**, wherein: said stent is arranged surrounding said valvular sleeve and includes a ring-like body at said inflow end of the valvular sleeve with a plurality of prongs extending from said ring-like body in a distal direction from said inflow end towards said outflow end of the valvular sleeve,

said prongs have a longitudinal slit,

said valvular sleeve includes folded portions which extend through the longitudinal slits of said prongs externally of said stent, and

peg members are inserted into said folded portions of the valvular sleeve externally to said stent to provide anchoring of said valvular sleeve to the stent.

**29.** The prosthetic valvular device of claim **28**, wherein: said prongs extend distally of said ring-like body from said inflow end towards said outflow end of the valvular sleeve with a tapered shape of said stent, said prongs have a longitudinal slit having an increasing width in said distal direction, and

said peg members are inserted wedge-like into said folded portions of the valvular sleeve to provide anchoring of said valvular sleeve to the stent, wherein the valvular sleeve is radially larger at said inflow end than at said outflow end.

**30.** The prosthetic valvular device of claim **25**, wherein said stent is collapsible.

\* \* \* \* \*