

(21) Application No 9120462.8

(22) Date of filing 26.09.1991

(71) Applicant  
IST Laboratories Ltd  
(Incorporated in the United Kingdom)

3 Marshall Road, Hillmead, Swindon, SN5 9FZ,  
United Kingdom

(72) Inventor  
Peter James Little

(74) Agent and/or Address for Service  
Boult Wade & Tennant  
27 Furnival Street, London, EC4A 1PQ,  
United Kingdom

(51) INT CL<sup>5</sup>  
G01S 1/68 3/18, G08B 21/00, H01Q 3/24, H04B  
1/034

(52) UK CL (Edition L)  
H4D DAB DFBC D34X D467 D468 D503 D504 D509  
D560  
H1Q QFD  
U1S S1146 S1178 S1834 S2195 S2317

(56) Documents cited  
GB 2212642 A WO 90/08060 A DE 003600802 A  
FR 002447318 A US 4673936 A US 4186396 A  
US 3996592 A US 2962715 A

(58) Field of search  
UK CL (Edition K) H1Q QFD QFE QFH QFJ, H4D  
DAB DBR DFAB DFBC DFX  
INT CL<sup>5</sup> G01S, G08B, H01Q, H04B  
W.P.I. INSPEC.

(54) A location system

(57) A location system 1 for locating a person 2 lost overboard from a vessel 3 comprises a transmitter 4 carried by the person, the transmitter being operable to transmit a radio distress signal. A receiver (19, Fig 4) is located on the vessel and is operable to receive a distress signal. The receiver comprises a composite antenna comprising an array of fixed dipoles 10, 11, 12, 13 connected to a switching unit 14 enabling the effective direction of the antenna to be cyclically swept to provide an indication of the direction from which the signal is received; this is done by connecting one dipole to the receiver electronics in turn, the other dipoles acting as reflectors to render the antenna directional.

FIG. 1.

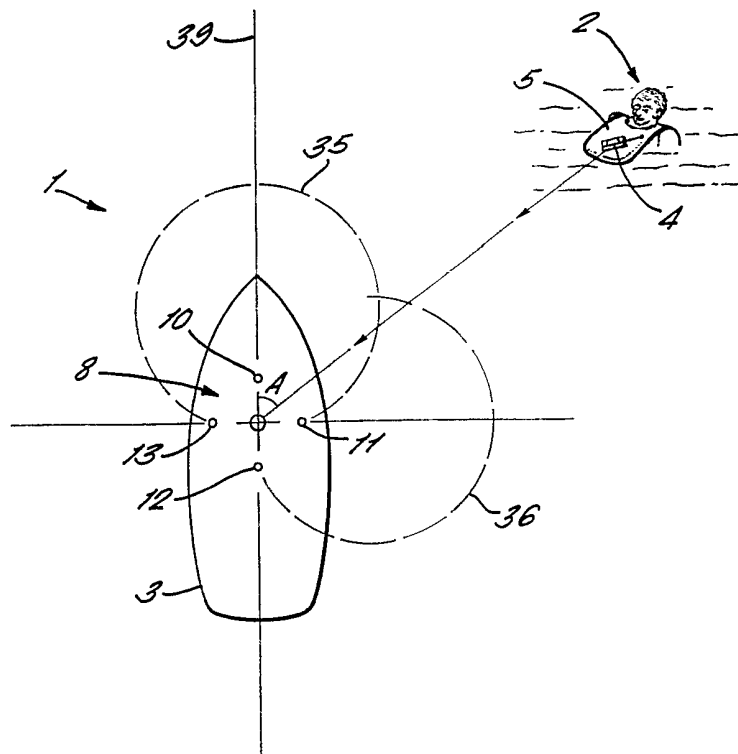

FIG. 1.

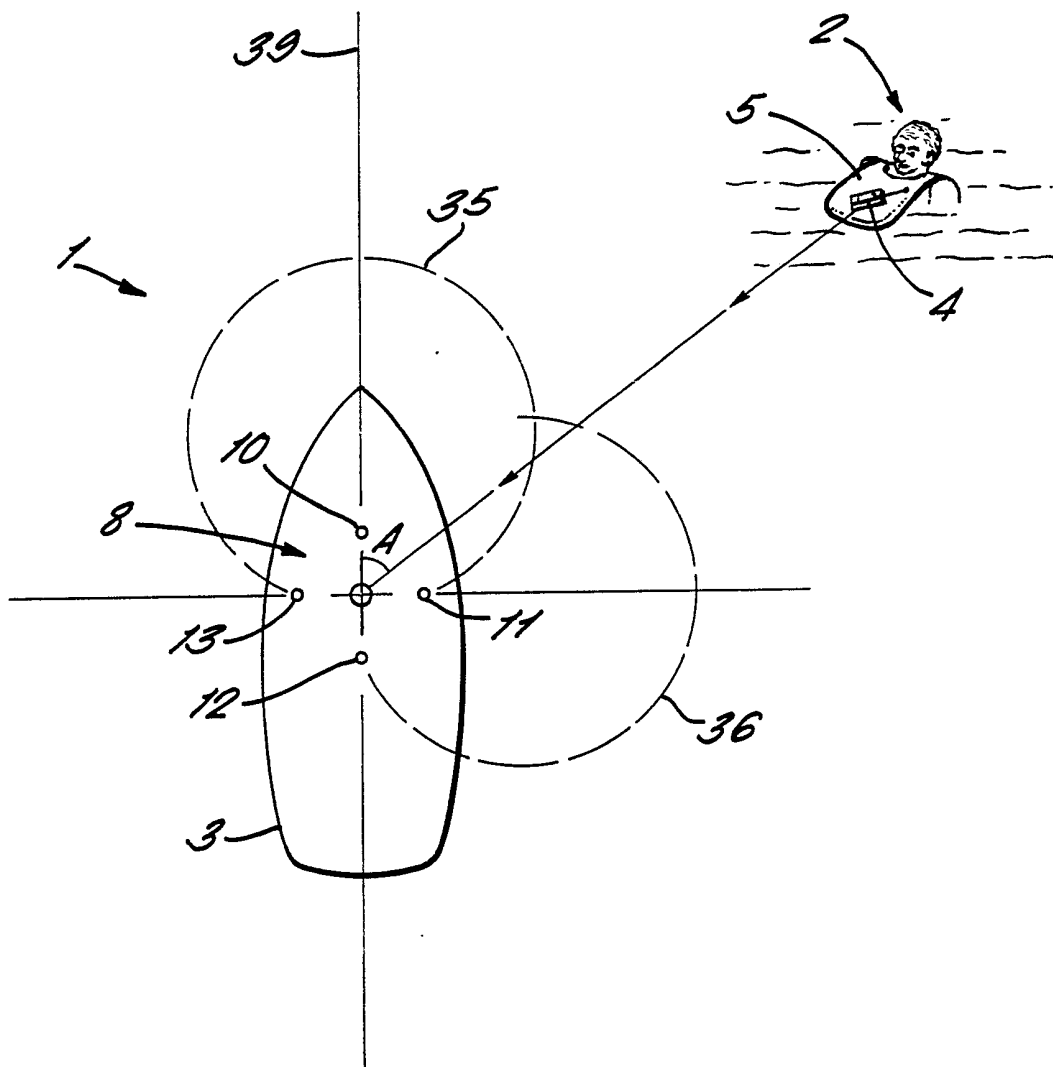

FIG. 2.

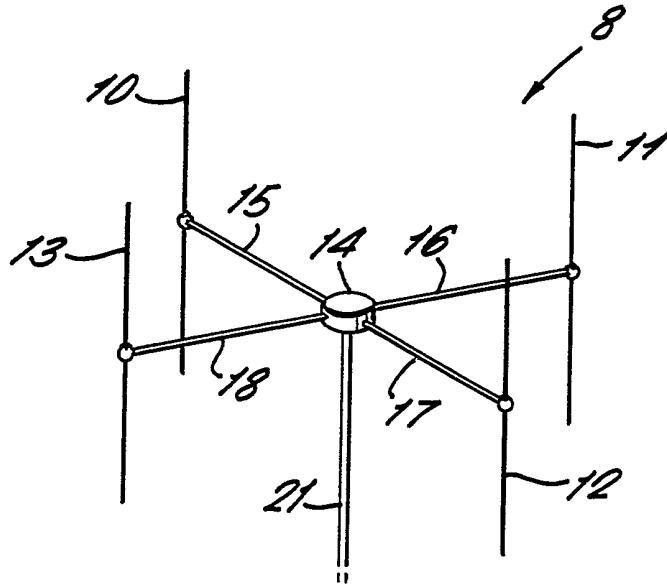

FIG. 3.

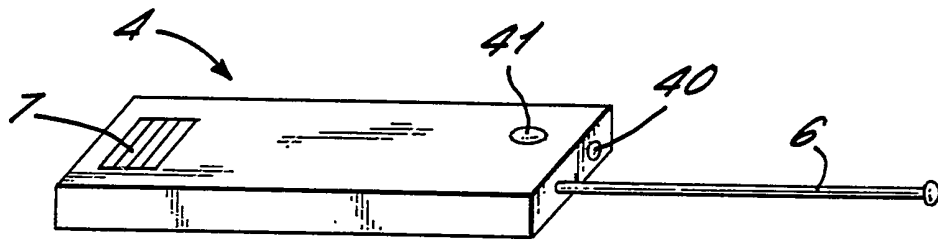
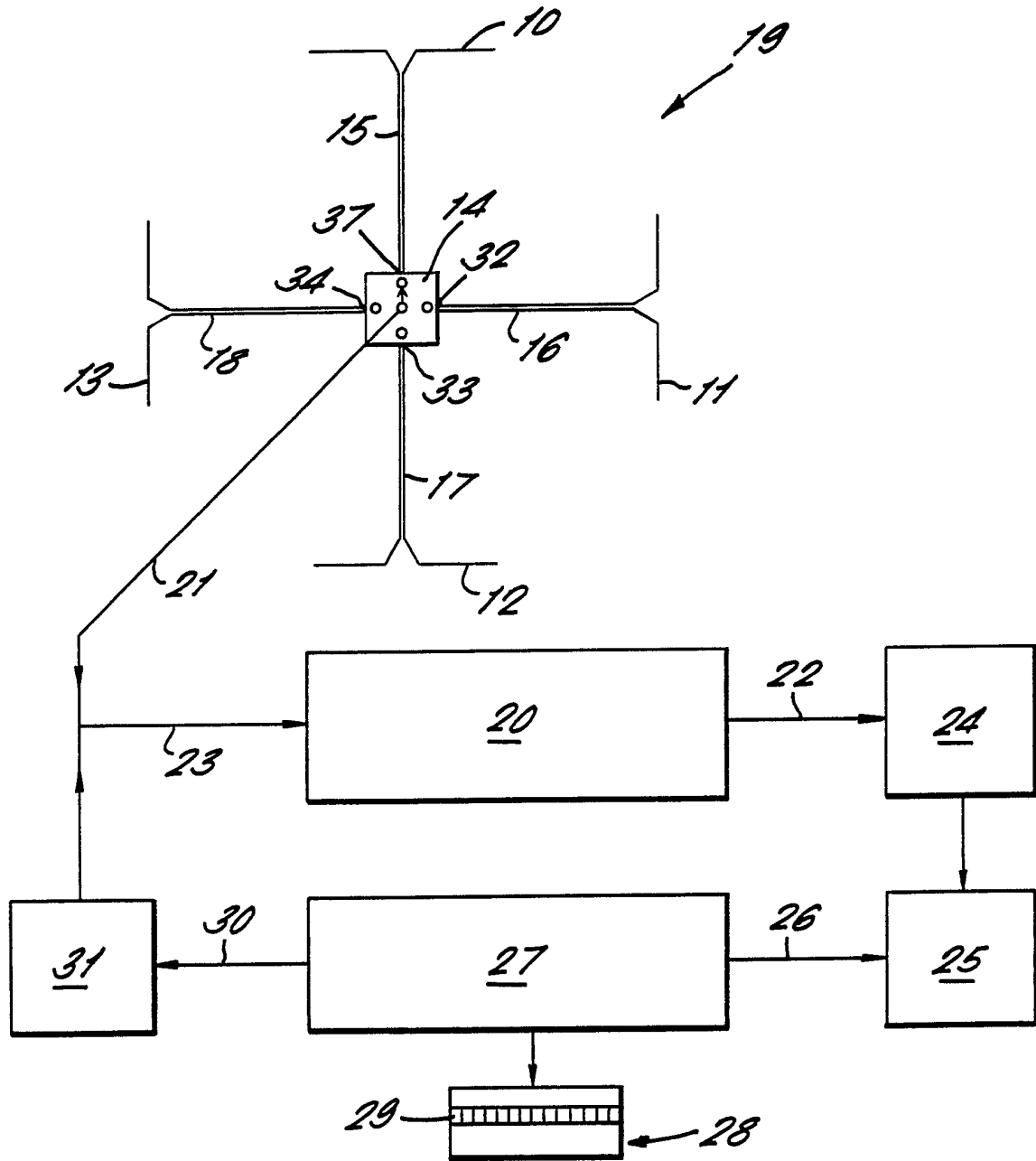

FIG. 4.



"A LOCATION SYSTEM"

This invention relates to a location system for locating a person lost overboard from a vessel.

5           According to the present invention there is disclosed a location system for locating a person lost overboard from a vessel comprising a transmitter carried by the person, the transmitter being operable to transmit a radio distress signal, a receiver  
10 located on the vessel and operable to receive the distress signal, and the receiver having direction finding means operable to provide an indication of the direction from which the signal is received.

          An advantage of this arrangement is that the  
15 vessel can immediately detect the event of a person having gone overboard and can then steer towards the person using the heading provided by the direction finding means.

          Preferably the direction finding means is  
20 operable to sense the angle between the received signal direction and a reference datum defined by the vessel.

          The direction finding means may comprise a composite antenna comprising an array of three or  
25 more fixed dipoles connected to a switching means operable to connect the output of a selected dipole to the receiver leaving the remaining dipoles to act as reflectors shaping in a directional manner the receiving characteristics of the selected dipole.

30           An advantage of this arrangement is that it avoids the need for a mechanically scanning antenna thereby simplifying the construction of the location system.

          Preferably the dipoles are connected to the  
35 switching means by a transmission line of substantially one quarter wavelength in length with

respect to the wavelength of the distress signal, the switching means being operable to connect the transmission line of the selected dipole to the receiver and make the remaining transmission lines  
5 open-circuit.

This makes use of the property of a quarter wavelength transmission line acting as a reflector by virtue of the standing wave effect. Connecting the dipole output to a quarter wavelength transmission  
10 line which is open circuit has the effect of short-circuiting the dipole so that it acts as a reflector.

Instead of one quarter wavelength, an odd multiple of quarter wavelengths will provide an equivalent effect so that for example a three quarter  
15 wavelength length of transmission line can be used.

In this way the switching of the dipoles can be carried out at a central location in a single switching unit thereby avoiding the need to provide separate switching devices at each dipole.

20 Preferably the composite array comprises four dipoles.

Preferably the direction of maximum sensitivity of the antenna is cyclically swept around the vessel such that the amplitude of the signal received from  
25 the transmitter is modulated at the sweep frequency, the receiver being operable to detect the modulation and determine the phase of the modulation relative to a control signal synchronising the start of each sweep with a direction defined by a reference datum  
30 of the vessel.

Such an amplitude modulation technique is simpler and more sensitive than known techniques of frequency modulation detection making use of Doppler shift effects.

35 Preferably the direction finding means is operable to sense the angle between the received

signal direction and a reference datum defined by the vessel.

A preferred embodiment of the present invention will now be described by way of example only and with reference to the accompanying drawings of which:-

Figure 1 is a schematic plan view of a vessel and a transmitter;

Figure 2 is a perspective view of the antenna of the vessel of Figure 1;

Figure 3 is a perspective view of the transmitter of Figure 1; and

Figure 4 is a schematic diagram of the receiver of the vessel of Figure 1.

Figure 1 shows schematically a location system 1 for locating a person 2 lost overboard from a vessel 3. The person 2 carries a transmitter 4 attached to a survival jacket 5. The transmitter 4 as shown in Figure 3 includes a transmitter aerial 6 and is actuated by a water sensitive switch 7 so that the transmitter begins to operate automatically when the person enters the water to transmit a distress signal at 121 MHz.

The transmitter 4 includes an arming switch 40 arranged such that the transmitter will not function when the arming switch is turned off. The transmitter 4 also includes a manual operating switch 41 which turns on the transmitter independently of the water sensitive switch 7.

The vessel 3 carries a composite antenna 8 also illustrated in perspective in Figure 2. The antenna 8 comprises an array of four vertically extending dipoles 10, 11, 12 and 13 each of which is connected to a switching unit 14 by respective coaxial cables 15, 16, 17 and 18. Each of the cables 15 to 18 is slightly longer than one quarter wavelength in length with respect to the distress signal.

The antenna 8 is mounted on the vessel 3 such that dipoles 10, 11, 12 and 13 are equispaced in a square array in positions in which they are respectively forward, starboard, rearward and port  
5 with respect to the vessel.

The antenna 8 forms part of a receiver 19 shown schematically in Figure 4. The switching unit 14 provides electronic switching of the dipoles 10, 11, 12 and 13 such that at any given time three selected  
10 dipoles are made to operate purely as reflectors by making their respective coaxial cables open-circuit at the switching unit. The switching unit 14 is connected to an AM (amplitude modulation) detection circuit 20 by a coaxial cable 21 to which a selected  
15 dipole output is connected so as to act as a receiving aerial. The detection circuit 20 produces an audio output signal 22 in response to amplitude modulation of the radio frequency input signal 23 which is input to the detection circuit. The audio  
20 output signal 22 is passed through a low pass filter 24 to an amplifier and comparator circuit 25 producing a square wave output signal 26 which is input to a control circuit 27.

A display unit 28 is connected to the control  
25 circuit 27 and is provided with 16 LED (light emitting diode) 29 arranged to provide an angular direction output indicator to the user.

A switching control signal 30 is transmitted from the control circuit 27 to the switching unit 14  
30 via the coaxial cable 21, there being provided a low pass filter 31 to exclude RF from the control circuit 27. The switching control signal 30 consists of a sequence of pulses each of which triggers the selection of the next dipole for connection to the  
35 detection circuit 20, the sequence including a reference pulse which synchronises the selection of



dipole 10 with the initiation of each cycle of the switching sequence.

The switching unit 14 functions to sequentially connect the output of dipoles 10 to 13 to the  
5 detection circuit 20 via the coaxial cable 21, at any given time only one selected dipole being connected to cable 21. In the position illustrated in Figure 4, dipole 10 is connected to the detection circuit 20. Coaxial cables 16, 17 and 18 are made  
10 open-circuit at their free ends 32, 33 and 34 respectively so as to reflect the respective received signals and the effect is that dipoles 11, 12 and 13 are effectively short-circuited to serve as reflectors forming the receiving polar diagram of  
15 dipole 10 into a forward looking shape as illustrated by broken line 35 in Figure 1. The antenna 8 at this time has a direction of maximum sensitivity which coincides with a reference axis 39 of the vessel which is exactly forward of the vessel and  
20 passing through the dipole 10.

The next step in the switching sequence is to connect dipole 11 with the detection circuit 20 and to open-circuit the cables 15, 17 and 18 of the remaining dipoles 10, 12 and 13 at their free ends  
25 37, 33 and 34 to produce the polar diagram 36 which is starboard facing as seen in Figure 1.

Continuing the switching sequence at a suitable audio frequency will therefore produce an amplitude modulation in the received signal corresponding to  
30 the effective rotation of the polar diagram in its four available positions.

This amplitude modulation of the received signal is detected by the detection circuit 20 and results in a sinusoidal audio signal 38 at the output  
35 of the low pass filter 34.

The phase of the sine wave audio signal 38 will

depend upon the angle A between reference axis 39 of  
the vessel 3 and the location of the transmitter 4  
and this phase angle is detected by the control  
circuit 27 which compares the phase of the square  
5 wave output 26 with the switching control signal 30  
which synchronises switching of the switching unit 14  
so as to make the location of dipole 10 coincident  
with the reference axis 39.

The control circuit 27 converts the phase  
10 measurement to a port or starboard angular  
measurement which is then visually displayed on  
display unit 28.

The composite antenna 8 may alternatively have  
other than four dipoles provided that the number of  
15 dipoles is at least three. If only two dipoles were  
used then this would provide insufficient data to  
determine the angular position of the transmitter.

Whilst more than four dipoles can be provided,  
the method of determining the transmitter angle by  
20 phase detection as described above gives sufficient  
angular information for the provision of further  
dipoles to be unnecessary.

The transmitter 4 will normally be actuated  
automatically on entry into the water by the water  
25 sensitive switch but may alternatively be actuated by  
manual use of the operating switch 41 which serves as  
a panic button.

30

35

CLAIMS:

1. A locating system for locating a person lost overboard from a vessel comprising a transmitter carried by the person, the transmitter being operable to transmit a radio distress signal, a receiver located on the vessel and operable to receive the distress signal and the receiver having direction finding means operable to provide an indication of the direction from which the signal is received.

2. A location system as claimed in claim 1 wherein the direction finding means is operable to sense the angle between the received signal direction and a reference datum defined by the vessel.

3. A location system as claimed in claim 2 wherein the direction finding means comprises a composite antenna comprising an array of three or more fixed dipoles connected to a switching means operable to connect the output of a selected dipole to the receiver leaving the remaining dipoles to act as reflectors shaping in a directional manner the receiving characteristics of the selected dipole.

4. A locating system as claimed in claim 3 wherein the dipoles are connected to the switching means by a transmission line of substantially one quarter wavelength or an odd multiple thereof in length with respect to the wavelength of the distress signal, the switching means being operable to connect the transmission line of the selected dipole to the receiver and make the remaining transmission lines open-circuit.

5. A locating system as claimed in any of

claims 3 and 4 wherein the composite antenna comprises four dipoles.

5           6.    A locating system as claimed in any of  
claims 3, 4 and 5 wherein the direction of maximum  
sensitivity of the antenna is cyclically swept around  
the vessel such that the amplitude of the signal  
received from the transmitter is modulated at the  
frequency of sweep, the receiver being operable to  
10   detect the modulation and determine the phase of the  
modulation relative to a control signal synchronising  
the start of each sweep with a direction defined by a  
reference datum of the vessel.

15           7.    A locating system substantially as  
hereinbefore described with reference to and as shown  
in any of the accompanying drawings.

20

25

30

35

**Patents Act 1977**  
**Examiner's report to the Comptroller under**  
**Section 17 (The Search Report)**

Application number

GB 9120462.8

**Relevant Technical fields**

(i) UK Cl (Edition K) H4D (DFAB, DFX, DFBC, DAB, DBR)  
H1Q (QFD, QFE, QFH, QFJ)

(ii) Int Cl (Edition 5) G015, G08B, H01Q, H04B

**Search Examiner**

DR E P PLUMMER

**Databases (see over)**

(i) UK Patent Office

(ii) WPI, INSPEC

**Date of Search**

13 JANUARY 1992

Documents considered relevant following a search in respect of claims

ALL

Category (see over)	Identity of document and relevant passages	Relevant to claim(s)
X Y	Whole document relevant in every case GB 2212642 (MARTIN ET AL) eg page 1 lines 7-9, page 6 lines 14-19, page 7 lines 12-15, page 10 lines 5-7 and 16 page 11 line 5	1,2, 3,4,5
X Y	WO 90/08060 (SEARCHRITE)	1,2, 3,4,5
X Y	DE 3600802 (REENTS)	1,2, 3,4,5
X Y	FR 2447318 (JAOUEN)	1,2, 3,4,5
X Y	US 4673936 (MITSUBISHI)	1,2, 3,4,5
X Y	US 4186396 (MITSUBISHI) nb column 1 lines 29-35 and Figures 1,2	1,2, 3,4,5
Y	US 3996592 (ORION)	3,4,5
Y	US 2962715 (MARCONI) eg column 1 lines 57-68, column 2 lines 27-38	3,4,5,6



Category	Identity of document and relevant passages	Relevant to claim(s)

**Categories of documents**

X: Document indicating lack of novelty or of inventive step.

Y: Document indicating lack of inventive step if combined with one or more other documents of the same category.

A: Document indicating technological background and/or state of the art.

P: Document published on or after the declared priority date but before the filing date of the present application.

E: Patent document published on or after, but with priority date earlier than, the filing date of the present application.

&: Member of the same patent family, corresponding document.

**Databases:** The UK Patent Office database comprises classified collections of GB, EP, WO and US patent specifications as outlined periodically in the Official Journal (Patents). The on-line databases considered for search are also listed periodically in the Official Journal (Patents).