

<p>(21) Application No 9604791.5</p> <p>(22) Date of Filing 06.03.1996</p> <p>(30) Priority Data (31) 07045571 (32) 06.03.1995 (33) JP</p>	<p>(51) INT CL⁶ H04B 10/22</p> <p>(52) UK CL (Edition O) H4B BK22</p> <p>(56) Documents Cited GB 1160438 A EP 0631401 A1 EP 0613320 A2 EP 0027833 A1 WO 94/01942 A1 WO 92/12580 A1 US 5307297 A</p> <p>(58) Field of Search UK CL (Edition O) G4H , H4B BKJ BK10 BK2 BK22 BK4 BK6 INT CL⁶ G06F , H04B</p>
<p>(71) Applicant(s) NEC Corporation (Incorporated in Japan) 7-1 Shiba 5-Chome, Minato-Ku, Tokyo 108-01, Japan</p> <p>(72) Inventor(s) Fumiyuki Kobayashi</p> <p>(74) Agent and/or Address for Service Reddie & Grose 16 Theobalds Road, LONDON, WC1X 8PL, United Kingdom</p>	

(54) Portable electronic apparatus having an infrared communication function

(57) A portable electronic apparatus 10 is provided with a housing 101 containing electronic circuits 202-205 necessary for the infrared communication function. On the side surfaces of the housing, a plurality of infrared emitting/receiving elements 104-107 are provided facing in different directions. The portable electronic apparatus is further provided with a selector 201 which selects at least one infrared emitting/receiving element from the infrared emitting/receiving elements in accordance with a selection signal, so as to provide an electrical connection between the selected infrared emitting/receiving element and the circuit contained in the housing. The infrared transmission can be established without changing the orientation of the apparatus. The apparatus can be used as the hub of a LAN to communicate with several other apparatuses (Fig. 5, not shown).

FIG. 2 A

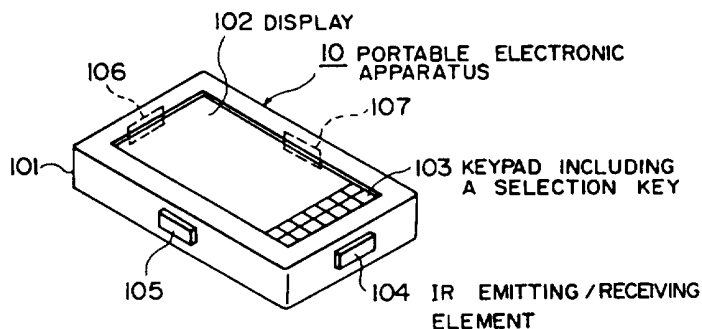

FIG. 2 B

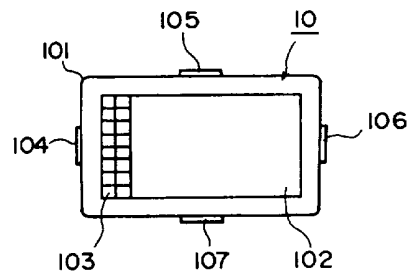

FIG. 1 (PRIOR ART)

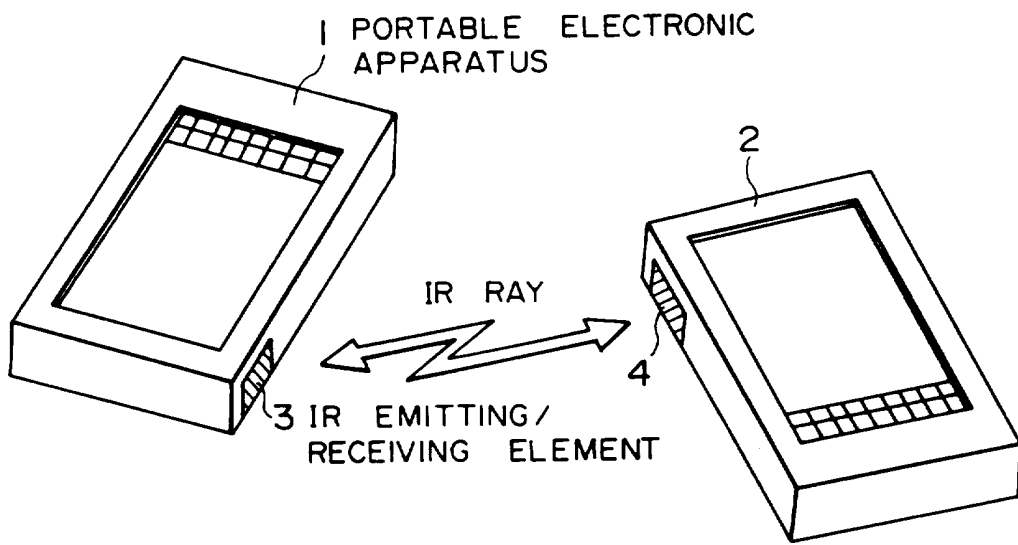

FIG. 2 A

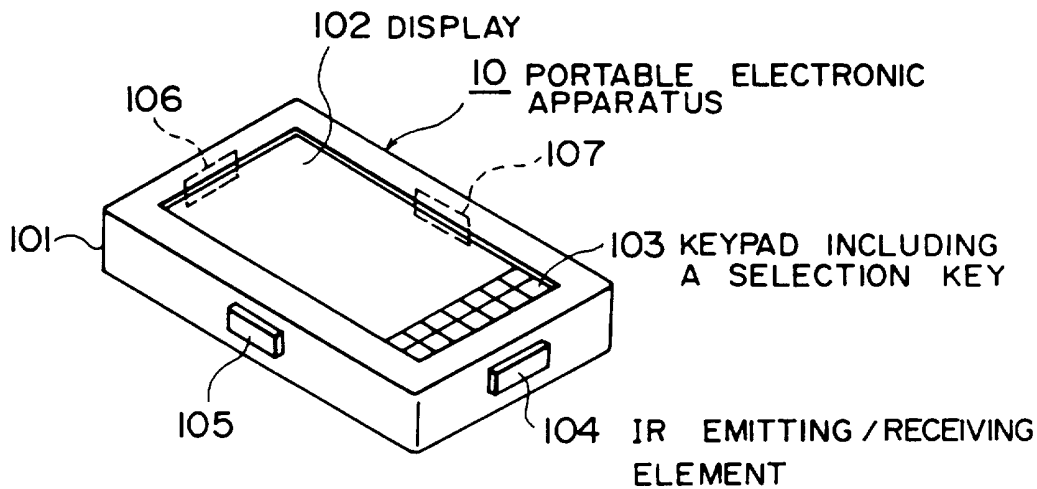

FIG. 2 B

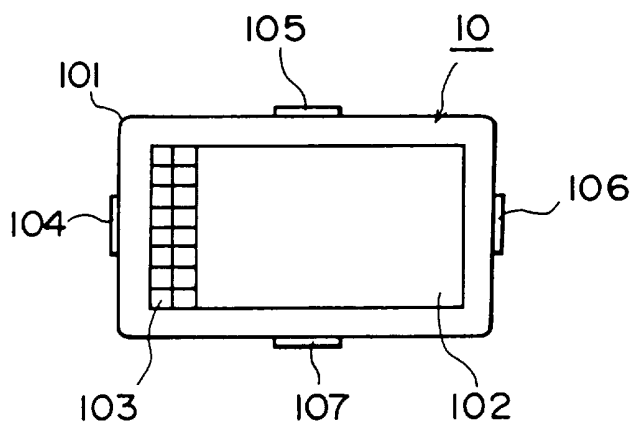

FIG. 3 A

10

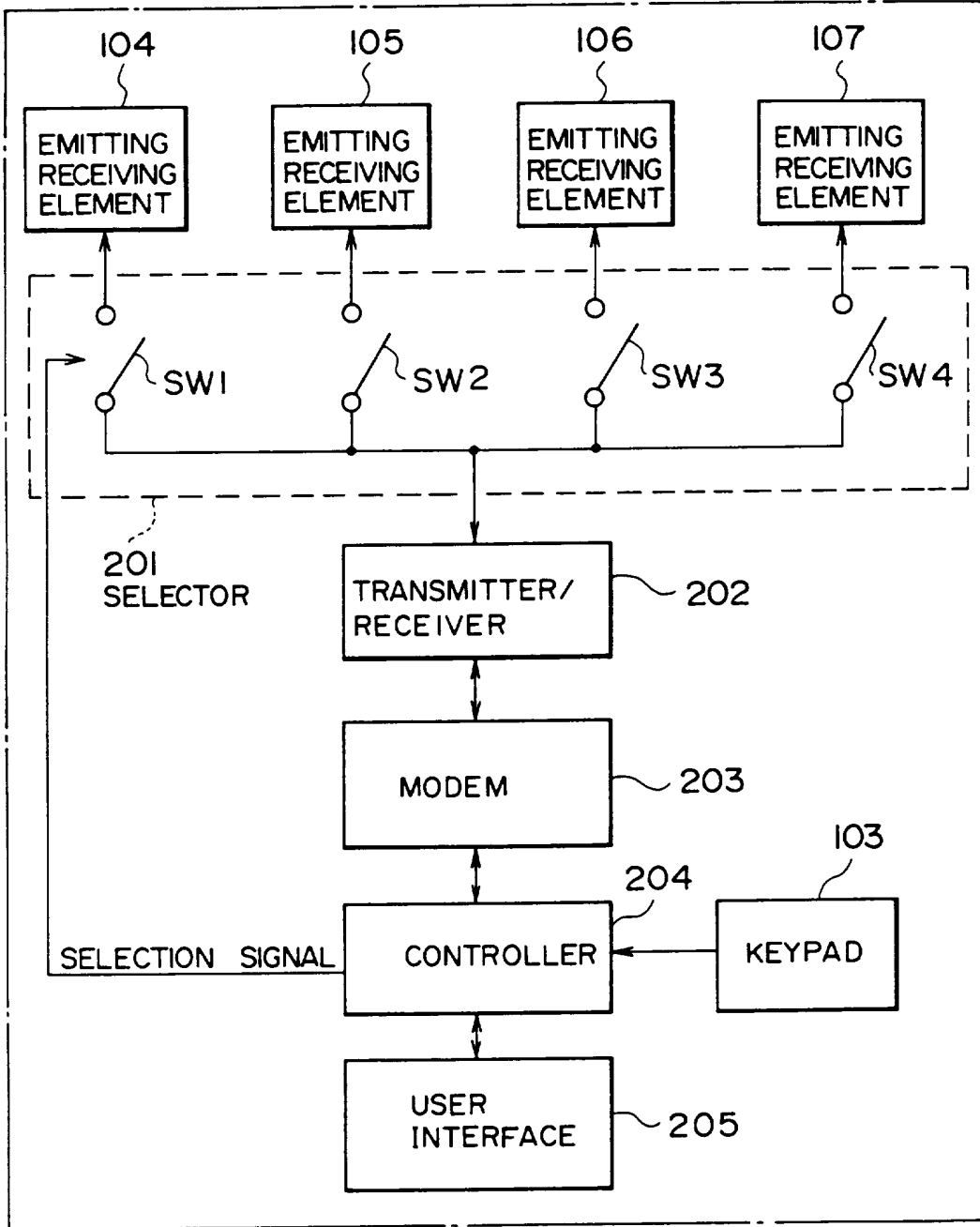

FIG. 3 B

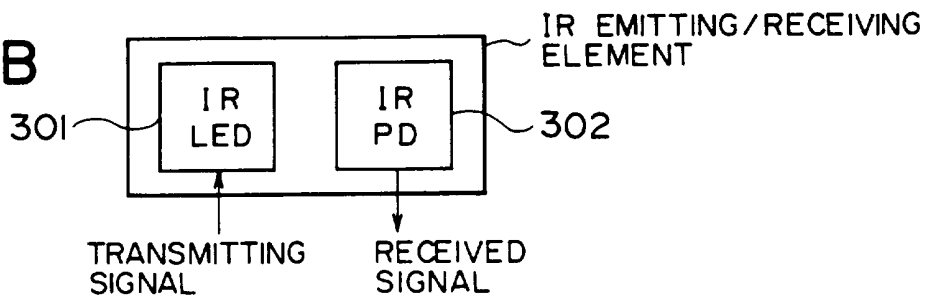

FIG. 4

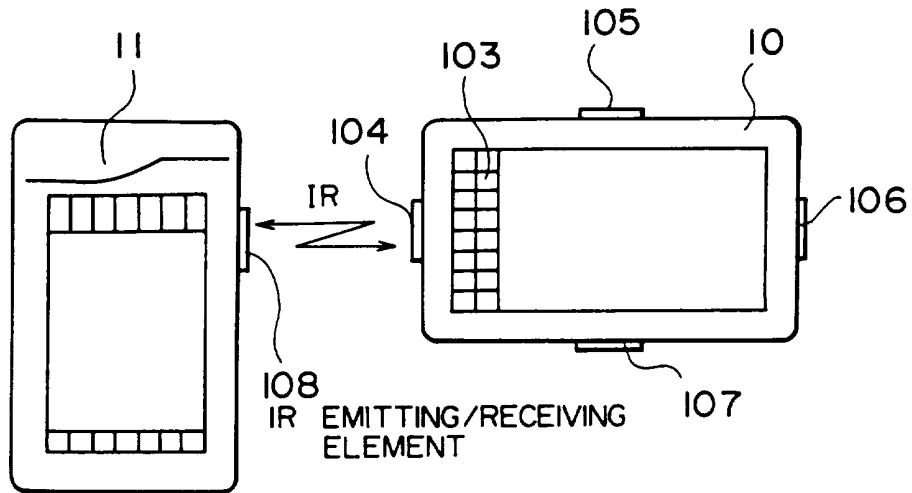
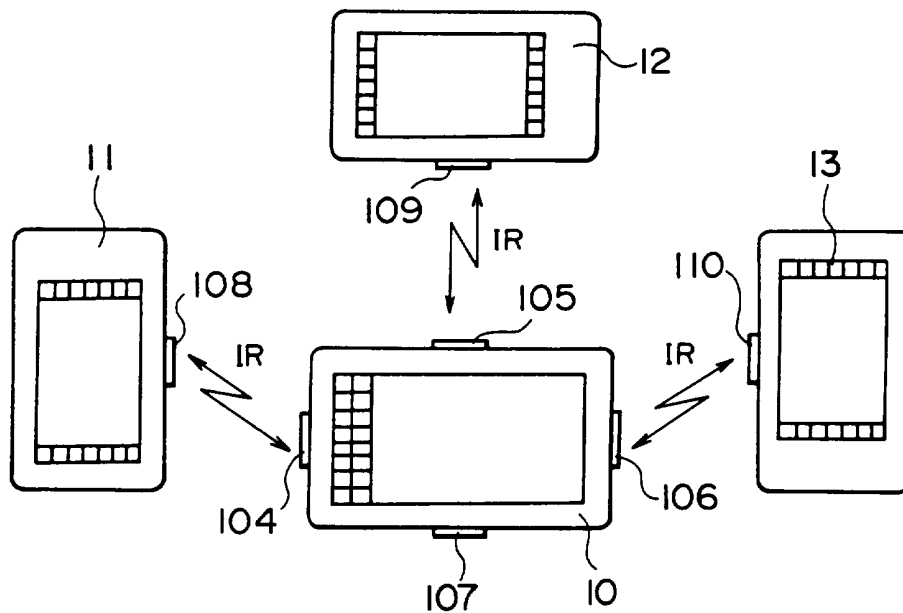

FIG. 5



PORTABLE ELECTRONIC APPARATUS HAVING
AN INFRARED COMMUNICATION FUNCTION

The present invention generally relates to a portable electronic apparatus, which term includes a portable calculator, a mobile information processing terminal, and a notebook-size computer, for example, and in particular to a portable electronic apparatus having an infrared communication function.

An infrared communication function has recently been provided in an increasing number of types of portable electronic apparatus. Using infrared components which are relatively inexpensive, wire-less data communications can easily be implemented between sender and receiver, or between each of these and a common target, over a relatively small area.

As shown in Fig. 1, in a known system respective portable electronic apparatuses 1 and 2 are provided with infrared (IR) emitting/receiving elements 3 and 4 built therein. In cases where data is transmitted from the portable electronic apparatus 1 to the other apparatus 2, and vice versa, the respective IR emitting/receiving elements 3 and 4 of the apparatuses 1 and 2 are directed towards each other so as to provide line of sight connection between them.

However, we have appreciated that such a known electronic apparatus is not easy to use in some situations. For instance, in cases where two users want to make data communication through IR transmission when seated in a conference room, the apparatuses 1 and 2 cannot transmit data to each other without being changed in direction (orientation) so as to direct the respective IR emitting/receiving elements 3 and 4 towards each other.

The present invention is defined in the independent claims below, to which reference should now be made. Advantageous features of the invention are set forth in the appendant claims.

A preferred embodiment of the invention is described in more detail below with reference to the drawings, and takes the form of a portable electronic apparatus the housing of which contains electronic circuits including a circuit necessary for the infrared communication function. On outside surfaces of the housing, a plurality of infrared emitting and/or receiving elements are provided facing in different directions. Preferably the infrared emitting/receiving elements are located on respective side surfaces of the housing. The portable electronic apparatus is further provided with a selector which selects at least one

infrared emitting/receiving element from the infrared
emitting/receiving elements in accordance with a
selection signal, so as to provide an electrical
connection between the selected infrared
5 emitting/receiving element and the circuit contained in
the housing. In other words, from the infrared
emitting/receiving elements pointing in different
directions, a desired infrared emitting/receiving
element is selected which is directed towards the
10 opposite apparatus, such as by a user instruction.

Therefore, the infrared transmission is made
with the reduced inconvenience of not having to change
the orientation of the apparatuses. Further, by
selecting a plurality of infrared emitting/receiving
15 elements, the portable electronic apparatus can make
infrared communications with plural other electronic
apparatuses. Furthermore, the portable electronic
apparatus may be used as a terminal or a central hub of
Ethernet LAN to provide an infrared communications
20 network.

The preferred embodiment of the invention will
now be described in more detail, by way of example, with
reference to the drawings, in which:

Fig. 1 (described above) is a diagram showing infrared transmission between known portable electronic apparatuses;

Fig. 2A is a perspective view showing a portable electronic apparatus according to the preferred embodiment of the present invention;

Fig. 2B is a plain view showing the portable electronic apparatus of Fig. 2A;

Fig. 3A is a block diagram schematically showing the internal circuit of the portable electronic apparatus according to the embodiment;

Fig. 3B is a schematic block diagram showing an IR emitting/receiving element in Fig. 3A;

Fig. 4 is a diagram showing an example of the infrared transmission between the portable electronic apparatus according to the embodiment and another electronic apparatus; and

Fig. 5 is a diagram showing another example of the infrared transmission between the portable electronic apparatus according to the embodiment and other electronic apparatuses.

Referring to Figs. 2A and 2B, a portable electronic apparatus 10 according to an embodiment of the present invention is composed of a housing 101 containing integrated circuits necessary

for implementing desired functions including the infrared communication function. The housing 101 has a display 102 such as a liquid crystal display (LCD) on the top surface thereof, and a keypad 103 is displayed on screen. The keypad 103
5 may be provided on a predetermined area of the top or side surface of the housing 101. The housing 101 is further provided with IR emitting/receiving elements 104-107 on the respective sides thereof. Since the shape of the housing 101 is a box as shown in the figures, the respective IR emitting/receiving elements
10 104-107 face in four directions each of which is normal to an adjacent direction. As described later, one desired IR emitting/receiving element is selected from the IR emitting/receiving elements 104-107 by a user operating a selection key included in the keypad 103. Each of the IR
15 emitting/receiving elements 104-107 has an IR light-emitting diode (LED) and a photodiode (not shown in these figures) therein.

Referring to Fig. 3A, in addition to the IR emitting/receiving elements 104-107 and a keypad 103, the apparatus 10 includes the following circuits necessary for IR
20 communication: a selector 201, a transmitter/receiver 202, a modulator/demodulator (modem) 203, a controller 204, and a user interface 205. The IR emitting/receiving elements 104-107 are connected to the selector 201 which selects one or more from the IR emitting/receiving elements 104-107 according to a selection
25 signal. The selector 201 is composed of switches SW1-SW4 which are formed with, for instance, an ON/OFF transistor. When a single

switch is selected by the selection signal, the selected switch is forced into conduction to provide an electrical connection between the transmitter/receiver 202 and the corresponding IR emitting/receiving element. Therefore, in accordance with the
5 selection signal, transmission signals and received signals may be transferred between the transmitter/receiver 202 and one or more IR emitting/receiving elements.

For simplicity, consider the case where the IR emitting/receiving element 104 is selected and a transmission
10 signal is transferred from the transmitter/receiver 202 to the IR emitting/receiving element 104. First, the controller 204 controls the user interface 205 such that the user can input a selection instruction through the keypad 103. According to the selection instruction, the controller 204 outputs the selection
15 signal to the selector 201, which selects the switch SW1 according to the selection signal. After that, transmission data is processed by the controller 204 and then the processed transmission data is modulated by the modem 203. Receiving the modulated transmission signal from the modem 203, the
20 transmitter/receiver 202 outputs the transmission signal to the IR emitting/receiving element 104 through the switch SW1 of the selector 201. The IR emitting/receiving element 104 converts the transmission signal into an IR ray signal to transmit it to the opposite party apparatus.

25 When receiving an IR ray signal from the opposite party apparatus, the IR emitting/receiving element 104 converts the IR

ray signal into an electric signal and outputs it to the transmitter/receiver 202 through the selected switch SW1 of the selector 201. The transmitter/receiver 202 sends the received signal to the modem 203 where the received signal is demodulated.

5 The demodulated signal is processed under control of the controller 204 and then transferred to a user interface 205 including a graphical user interface displayed on the display 102.

In this manner, the IR transmission is made through the selected IR emitting/receiving element 104. It is the same with

10 the IR emitting/receiving elements 105-107. According to the user's selection instruction, a desired IR transmission direction is selected by the selector 201.

As illustrated in Fig. 3B, each of the IR emitting/receiving elements 104-107 is composed of the IR light-emitting diode (LED) 301 and the photodiode (PD) 302. Therefore, when receiving the

15 transmission signal, the LED 301 emits an IR ray signal according to the transmission signal. On the other hand, when receiving an IR ray signal from the opposite party apparatus, the photodiode 302 converts the IR ray signal into an electric signal and then

20 transfers it to the transmitter/receiver 202 through the selected switch of the selector 201.

According to this embodiment, the infrared transmission can be made in four different directions by forcing one or more switches of the selector 201 into conduction without changing the

25 orientation of the apparatus 10. Needless to say, in cases where the housing 101 is polygonal, the housing 101 may be provided

with three or more IR emitting/receiving elements on the respective sides thereof.

As illustrated in Fig. 4, it is assumed that the IR emitting/receiving element 104 of the portable electronic apparatus 10 is directed toward the IR emitting/receiving element 108 of another portable electronic apparatus 11. In this case, the user of the apparatus 10 selects the IR emitting/receiving element 104 by operating the keypad 103, and then starts the IR communication with the portable electronic apparatus 11.

As illustrated in Fig. 5, the portable electronic apparatus 10 embodying the present invention may be used to make IR communications with a plurality of other electronic apparatuses 11-13. From another view point, the portable electronic apparatus 10 may be used as a terminal or a hub of Ethernet LAN (local area network) as known well to make IR communications with a plurality of other electronic apparatuses. Consider the case where the IR emitting/receiving elements 104-106 of the portable electronic apparatus 10 are directed toward the IR emitting/receiving elements 108-110 of other portable electronic apparatuses 11-13, respectively. In this case as shown in Fig. 5, the user of the apparatus 10 selects the IR emitting/receiving elements 104-106 by operating the keypad 103. By this user's operation, the respective switches SW1-SW3 are forced into conduction to provide electric connections between the transmitter/receiver 202 and these IR emitting/receiving elements 104-106. Therefore, the apparatus 10 enables the provision of

plural IR communications by selecting a plurality of IR emitting/receiving elements.

As described above, the portable electronic apparatus 10 can easily provide wide-angle IR communications with other apparatuses without the inconvenience of changing the orientation of the apparatus 10. Further, it is preferable that each side of the apparatus housing is provided with an IR emitting/receiving element.

CLAIMS

1. A portable electronic apparatus having an infrared communication function, the apparatus comprising:

5 a housing containing electronic circuits including a circuit necessary for the infrared communication function;

10 a plurality of infrared elements for emitting and/or receiving infrared rays, the infrared elements being provided on outside surfaces of the housing facing in different directions; and

15 a selector for selecting at least one infrared element from the infrared elements in accordance with a selection signal so as to provide an electrical connection between at least one selected infrared element and the said circuit contained in the housing.

2. Apparatus according to claim 1, wherein the infrared elements are provided in respective side surfaces of the housing.

20 3. Apparatus according to claim 1 or 2, wherein the housing has a box-like shape.

25 4. Apparatus according to claim 1, wherein the selector comprises a plurality of switches which connect the infrared elements to the circuit, at least one of the switches being forced into conduction in accordance with the selection signal.

5. Apparatus according to any of claims 1 to 4, wherein each of the infrared elements comprises:

an infrared light-emitting device for emitting an infrared ray according to a transmission signal received from the circuit; and

an infrared detector for detecting an infrared ray to convert the infrared ray into a received signal.

6. Apparatus according to claim 5, wherein the said circuit necessary for the infrared communication function comprises:

a transmitter-receiver for sending the transmission signal to the selector and receiving the received signal from the selector;

a user interface for presenting information to a user and input of instructions including a selection instruction from the user; and

a controller for controlling the selector, the transmitter-receiver, and the user interface such that the selection signal is sent to the selector in accordance with the selection instruction, and the infrared communication function is performed through the selector which selects at least one of the switches in accordance with the selection signal.

7. A method of infrared communication between a portable electronic apparatus and another electronic apparatus which are both provided with an infrared communication capability, the method comprising the steps of:

providing a plurality of infrared elements facing in different directions on outside surfaces of the portable electronic apparatus;

5 selecting an infrared element from the infrared elements to provide an electrical connection between the selected infrared element with the infrared communication circuit of the portable electronic apparatus, the selected infrared element being substantially directed towards the other electronic apparatus; and

10 performing infrared communication with the other electronic apparatus through the selected infrared element.

8. A method of infrared communication between a portable electronic apparatus and a plurality of the electronic apparatuses which are all provided with an infrared communication circuit therein, the method comprising the steps of:

15 providing a plurality of infrared elements facing in different directions on outside surfaces of the portable electronic apparatus;

20 selecting a plurality of selected infrared elements from the infrared elements to provide electrical connections between the selected infrared elements with the infrared communication circuit of the portable electronic apparatus, the selected infrared elements being substantially directed towards the respective other electronic apparatuses; and

25 performing infrared communication with the electronic apparatus through the selected infrared elements.

30

9. An infrared communication network comprising:
a central electronic apparatus including a
housing containing electronic circuits including a
circuit necessary for the infrared communication
5 function; a plurality of infrared elements for emitting
and/or receiving infrared rays, the infrared elements
being provided on outside surfaces of the housing facing
in different directions; and a selector for selecting a
plurality of selected infrared elements from the
10 infrared elements in accordance with a selection signal
so as to provide electrical connections between the
selected infrared elements and the said circuit
contained in the housing; and

a plurality of other electronic apparatuses each
15 having an infrared element for emitting and/or receiving
an infrared ray signal, the infrared elements of the
other electronic apparatuses being directed towards the
respective selected infrared elements.

10. A portable electronic apparatus having an
20 infrared communication function, substantially as herein
described with reference to Figs. 2A - 5 of the
drawings.

11. A method of infrared communication, substantially
as herein described with reference to Figs. 2A - 5 of
25 the drawings.



Application No: GB 9604791.5
Claims searched: 1 to 8

Examiner: Dr E P Plummer
Date of search: 14 May 1996

Patents Act 1977
Search Report under Section 17

Databases searched:

UK Patent Office collections, including GB, EP, WO & US patent specifications, in:
UK Cl (Ed.O): H4B(BKJ,BK2,BK4,BK6,BK10,BK22), G4H
Int Cl (Ed.6): H04B, G06F
Other:

Documents considered to be relevant:

Category	Identity of document and relevant passage	Relevant to claims
A	GB1160438 Burton	
X	EP0631401A1 Canon KK	1,2,4-8
A	EP0613320A2 Sony Corp	
A	EP0027833A1 Siemens	
X	WO94/01942A1 Motorola eg figure 2, page 5 lines 6 to 20	1-8
A	WO92/12580A1 Light Ideas Inc	
X	US5307297 Sharp KK - column 2 lines 5 and 6, figures 15 and 16 and column 5 lines 55 to 64	1-8

X	Document indicating lack of novelty or inventive step	A	Document indicating technological background and/or state of the art.
Y	Document indicating lack of inventive step if combined with one or more other documents of same category.	P	Document published on or after the declared priority date but before the filing date of this invention.
&	Member of the same patent family	E	Patent document published on or after, but with priority date earlier than, the filing date of this application.