



(11) (21) (C) **2,071,240**  
(22) 1992/06/15  
(43) 1992/12/18  
(45) 2000/10/24

(72) Bisch, Michael Evremonde, US

(72) Khuhro, Shafiq Ahmed, US

(72) Dicarlo, Paul, US

(73) OTOLOGICS, L.L.C., US

(51) Int.Cl.<sup>5</sup> H04R 25/00

(30) 1991/06/17 (07/716,584) US

(54) **TRANSDUCTEUR IMPLANTABLE HERMETIQUEMENT  
SCELLE**

(54) **HERMETICALLY SEALED IMPLANTABLE TRANSDUCER**

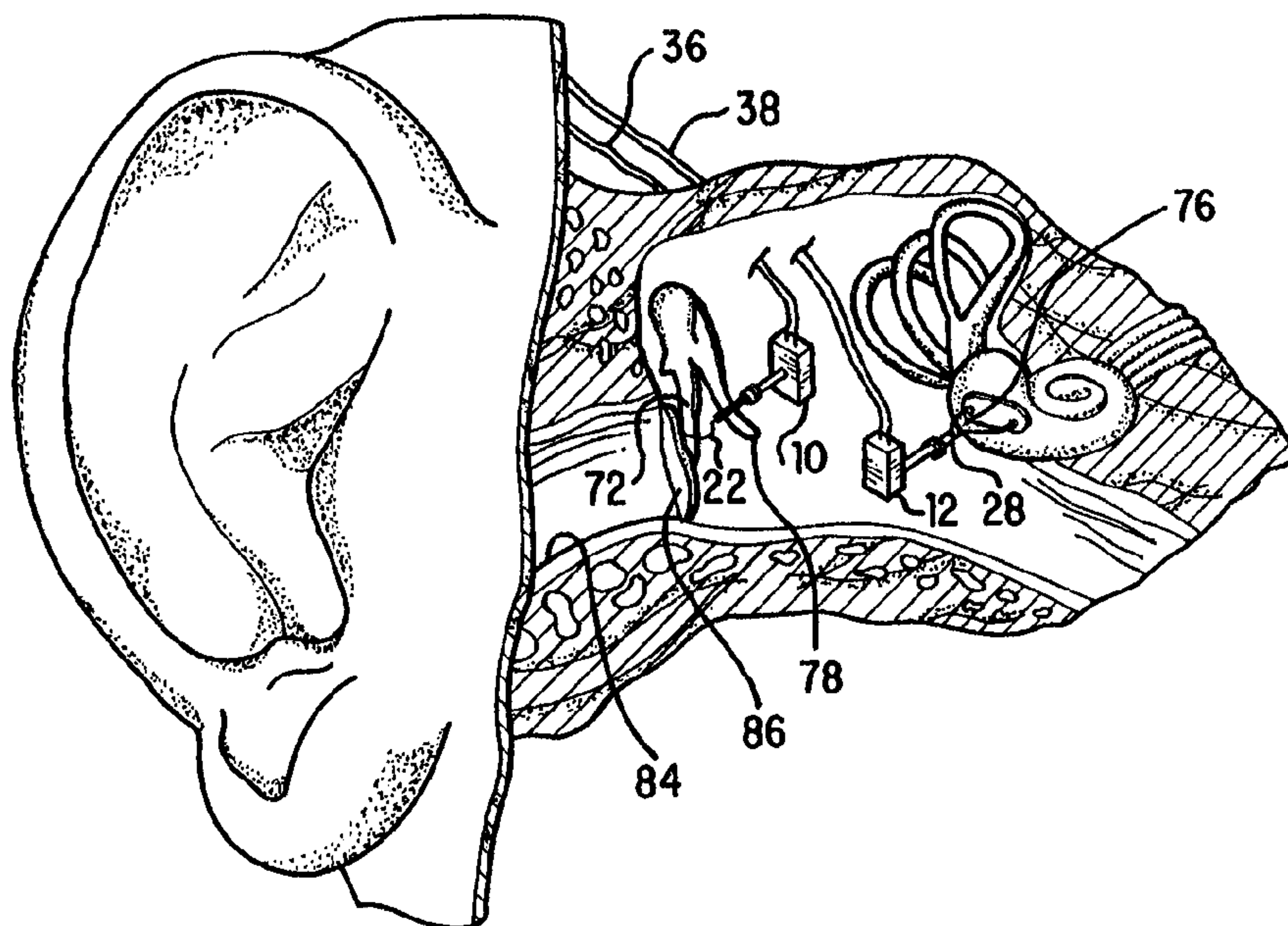

(57) A hermetically sealed transducer mechanism for an implantable hearing aid system having a signal processing unit having at least one electromechanical transducer coupled to the auditory system of a human. The transducer having an outer casing and at least one moving member extending outside the casing. The invention comprising a hermetically sealed bellows member having two ends and a generally cylindrical side wall. One end of the bellows member being hermetically affixed to the transducer casing and the other end of the bellows member being hermetically affixed to the moving member at a point outside the transducer casing. The side wall having a plurality of corrugations formed therein to allow the moving member to vibrate independently from the transducer casing while providing a hermetic seal protecting the interior of the transducer.



2071240

Case No. 31,168

HERMETICALLY SEALED IMPLANTABLE TRANSDUCER

ABSTRACT OF THE DISCLOSURE

A hermetically sealed transducer mechanism for an implantable hearing aid system having a signal processing unit having at least one electromechanical transducer coupled to the auditory system of a human. The transducer having an outer casing and at least one moving member extending outside the casing. The invention comprising a hermetically sealed bellows member having two ends and a generally cylindrical side wall. One end of the bellows member being hermetically affixed to the transducer casing and the other end of the bellows member being hermetically affixed to the moving member at a point outside the transducer casing. The side wall having a plurality of corrugations formed therein to allow the moving member to vibrate independently from the transducer casing while providing a hermetic seal protecting the interior of the transducer.

Case No. 31,168

HERMETICALLY SEALED IMPLANTABLE TRANSDUCER

BACKGROUND OF THE INVENTION

5 The present invention relates generally to  
implantable hearing aids and, more particularly, to an  
implantable hearing aid having one or more hermetically  
sealed transducers for direct coupling to the middle  
ear. The electroacoustic transducers of the present  
10 invention may be either a microphone or a hearing aid  
receiver within the implantable hearing aid of the  
present invention.

15 The implantable hearing aid is intended to  
help a specific class of patients for which convention-  
al hearing aids are inadequate. These patients have  
severe hearing impairments and require excessive  
amplification. Conventional means are limited by  
20 acoustic feedback and sound distortion. Patients have  
reported an increased clarity of sound and were able to  
identify speech equal to or better than that reported  
with conventional aids by using amplified sound direct-  
25 ly coupled to the middle ear bones.

30 An important requirement of an implantable  
hearing aid is for its components to be hermetically  
sealed so that the environment existing inside the  
middle ear cavity does not corrode and/or destroy the  
internal parts of the hearing aid device. In the  
embodiment of the prior art, a transducer is acousti-  
cally connected to an acoustical coupler. The

acoustical coupler has a compliant synthetic rubber diaphragm or membrane is stretched across one end of the coupler which, when the coupler is used as a microphone, may be physically attached to the handle of the malleus by a wire hook, or it may be positioned to acoustically couple with the tympanic membrane. When the coupler is to be used as a transmitter or vibrator, the diaphragm can be physically attached to the stapes or other middle ear bone via an intermediate porous ceramic wafer which is glued to the diaphragm.

However, while the synthetic rubber membranes are easily vibrated for the transmission of sound waves, it may be difficult to actually obtain the necessary hermetic seal between the diaphragm and body of the acoustic coupler. The diaphragms of the prior art devices are typically manufactured from a porous synthetic rubber material which does not provide a proper hermetic seal to adequately protect the interior of the acoustical couplers. It would be desirable to have the diaphragm manufactured from a metal or non-porous material; however, it is important that the diaphragm not lose any of its compliancy so as to be able to properly transmit the acoustical pulsations or vibrations through the acoustic coupler.

In a second embodiment of the prior art acoustical couplers, a tube having a movable piston is disclosed which is mechanically coupled either between the malleus or tympanic membrane and the transducer or between the transducer and one of the middle ear bones. However, no structure is disclosed in the prior art for providing such a hermetically sealed acoustic coupler.

Accordingly, one of the objects of the present invention is to provide a transducer for use inside the middle ear cavity having a totally hermetically sealed container without compromising the function of the transducer and acoustic coupler of the prior art devices.

5 It is another object to provide a hermetically sealed means for use with existing transducers to provide an implanted middle ear assistance device capable of use without significant modification of the existing transducers.

SUMMARY OF THE INVENTION

10 The present invention provides a transducer having a hermetically sealed bellows member for direct insertion into the middle ear cavity. The transducer is sized to fit within the middle ear cavity without significant surgical alteration of the cavity. It can be used as a microphone for coupling with the malleus, the tympanic membrane or the external ear canal. The  
15 transducer may also be used as a receiver to act as a vibrator for causing mechanical vibration of one of the middle ear bones.

The transducer, in one embodiment, comprises an outer tubing member having a bellows member soldered  
20 or otherwise attached to the end of the outer tubing member. The bellows member is likewise soldered or otherwise permanently affixed to an inner rod or pin extending axially within the outer tubing member and extending from the transducer body outwardly through  
25 the center of the bellows member. The ends of the bellows member may be manufactured with flanges thereon or provided with other features to provide soldering surfaces for connection to the outer tubing means and inner rod or tube, respectively.

30 The side wall of the cylindrical portion of the bellows member having a plurality of generally "U" shaped corrugations provided therein to allow the inner rod extending outwardly from the transducer to vibrate axially relative to the outer cylindrical tubing in  
35 response to internal or external mechanical or acoustical vibrations depending on the end use of the transducer (i.e. transducer is connected as a microphone or

receiver as discussed above). The material of the bellows member is preferably gold plated nickel or other biocompatible metals which are non-porous and of sufficient strength and flexibility to allow the bellows member to be made small and strong enough for use  
5 in the middle ear cavity and still retain the necessary flexibility to allow the inner rod or tube to transfer the mechanical or acoustical vibrations to or from the transducer as the case may be. The outer end of the inner rod or tube of the transducer may be physically coupled to the handle of the malleus by a wire hook or  
10 it may be positioned to couple with the tympanic membrane or membrane of the external ear cavity when used as a microphone. When the transducer is to be used as a receiver or vibrator, the outer end of the inner rod or tube of the transducer can be physically attached to or abutted against one of the middle ear  
15 bones to transmit the vibrations to the cochlea.

More specifically, the present invention provides a hermetically sealed acoustic mechanism for a partially implanted hearing aid system including an electromechanical transducer, comprising:

20 at least one moving member in said transducer to transmit mechanical vibrations to a middle ear component for producing the perception of sound in the ear;

a bellows member for hermetically sealing the vibrating joint between the transducer and said moving member;

25 means for attaching said bellows member to said transducer in a hermetic fashion; and

means for attaching said bellows member to said moving member in a hermetic fashion.

The present invention also provides an implantable  
30 hearing aid for the middle ear comprising:

signal processing means including signal processing circuitry and power means;

4a

a sound pick-up transducer means electrically connected to said signal processing means, said transducer means having an outer casing and at least one movable member;

a hermetically sealed bellows member having first and second ends, and a generally cylindrical side wall, the first and second ends having flanges thereon, the side wall having a plurality of corrugations provided therein to allow the second end of said bellows member to move independently of the first end of said bellows member;

10 first coupling means for hermetically connecting the flange of said first end of the bellows member to said transducer casing; and

second coupling means for hermetically connecting the flange of said second end of said bellows member to said movable member whereby sound vibrations in said first middle ear member are transmitted from said moveable transducer member to said sound pick-up transducer means for generation of a resultant signal means by said signal processing means.

20 BRIEF DESCRIPTION OF THE DRAWINGS

The invention will become more apparent from the following detailed description, taken in conjunction with the appended drawings, in which:

Fig. 1 is an anterior view of the human ear with one form of the invention implanted therein;

Fig. 2 is a posterior view of the human ear with one form of the invention implanted therein;

Fig. 3 is a detailed perspective view of the present invention;

30 Fig. 4 is an enlarged perspective view of the human ear illustrating the invention shown in Fig. 3 in use;

4b

Fig. 5 is a cross-sectional view of the preferred embodiment of the present invention;

Fig. 6 is an enlarged cross-sectional view of the hermetically sealing bellows member of the



connection means of the present the invention shown in Fig. 5; and

Fig. 7 is an anterior view of the human ear illustrating the invention implanted thereon in an alternate manner of use.

DETAILED DESCRIPTION OF THE PREFERRED EMBODIMENT

The present invention provides a hermetically sealed transducer which may be used for both sound pick-up and sound delivery systems. In order to illustrate both of these uses, Figure 3 illustrates the present invention providing both sound pick-up and sound delivery systems. Referring to Figure 3, a sound pick-up mechanism 10 and a sound delivery mechanism 12 are illustrated.

The sound pick-up mechanism 10 includes an electromechanical transducer 14 (which acts as a microphone), an outer tube member 16, an inner tube or rod member 18 which extends beyond the end of the outer tube member 16 and a connective means 20 for providing a hermetically sealed connection between the inner and outer tube members 18 & 16, respectively (discussed in more detail below). The outer end of tube or rod member 18 may be connected to a wire hook 22 either by welding or other attachment means. The hook 22 is shaped to attach to one of the ossicular bones within the ear and serves to physically couple movement of the ossicular chain to transducer 14. Alternatively, the outer end of inner tube or rod can be made to acoustically couple with the tympanic membrane or membrane of the outer ear cavity as discussed in more detail below.

The sound delivery mechanism 12 is very similar in overall configuration to the sound pick-up mechanism 10. The sound delivery mechanism 12 includes an electromechanical transducer 24 (which acts as a transmitter), an outer tube member 26, an inner tube or rod member 28 which extends beyond the end of the outer

tube member 26, and a connective means 30 for providing a hermetically sealed connection between the inner and outer tube members 28 and 26, respectively, as disclosed in more detail below. The outer end 32 of inner tube member 28 would then be affixed in any suitable manner to one of the existing inner ear bones to transmit the vibrations to the cochlea.

It is to be understood that the above-described means of attachment to the selected ossicular bones are presently preferred. However, there are alternate means for effecting acoustical coupling between the transducers and the ossicular member of interest. Where direct physical coupling to an inner ear bone is not required, sound pick-up mechanism 10 can be fashioned without wire hook 22. In this instance, the end of the inner tube member 18 is positioned within the middle ear either in contact with or behind the tympanic membrane of the ear so that movement of the tympanic membrane imparts a corresponding movement in inner tube or rod 18 by direct contact in the first case or by sound pressure variations in the entrapped air volume of the middle ear in the second case. In such an application, it may be necessary to give attention to placement of the sound pick-up mechanism 10 so that it does not lie on a standing wave null point within the middle ear cavity.

The electromechanical transducer 14 of the sound pick-up mechanism 10 and the electromechanical transducer 24 of the sound delivery mechanism 12 are both connected to a sound reinforcement and processing package 34 via two pairs of wires 36 and 38, respectively. The sound reinforcement and processing package 34 is preferably located outside the middle ear cavity as illustrated in Figures 2, 4 and 7. The package 34 typically would include amplification and signal processing electronic circuitry (not shown) to enable it to receive an electronic signal from the

microphone/transducer 14 and transfer such signal in a readable fashion to the receiver/transducer 24 for transfer to the inner ear. To provide electrical power for operating the electronic circuitry, a battery 40 is secured to and electronically connected to the electronic circuitry within package 34. Preferably the battery 40 is rechargeable and the electronic circuitry includes an inductively coupled circuit means (not shown) for recharging the battery. In this regard, the circuit means would include an electromagnetic coil which would be positioned near the surface of the patient's skin and forms the secondary windings of a transformer. When it is desired to recharge battery 40, an external coil (not shown) is placed on or near the skin adjacent to the electromagnetic coil of the circuit means and forms the primary windings of a transformer. The primary and secondary coils are electromagnetically coupled with one another to form a transformer through which electrical energy is conveyed to charge battery 40.

To more fully describe the design of the sound pick-up mechanism 10 and the sound delivery mechanism 12 of Fig. 3, please refer to Figs. 5 and 6 wherein one such mechanism 48, enlarged greatly and in partial cross-section is shown. The basic designs of sound pick-up mechanism 10 and sound delivery mechanism 12 are the same so for illustrative purposes only one such mechanism will be described here. The differences in the sound pick-up and delivery mechanisms relate to the manner in which the tips are connected into the ossicular chain (i.e. hook 22 or rod 28 as discussed above) and whether the mechanism is acting as a microphone or receiver. The detailed manner in which an electromechanical transducer operates will not be discussed here and for a more detailed understanding of the operation of such a transducer, please refer to

U.S. Patent No. 4,988,333.

5 The transducer referred to herein, whether acting as a sound pickup (microphone) or sound delivery (receiver) mechanism, utilizes the same connective means 54 to provide the proper hermetic seal for such transducers as described in the following paragraphs.

10 Referring to Fig 5, the preferred embodiment of the transducer (used as either a microphone or receiver), is illustrated. An electromechanical transducer 50 is shown having an outwardly extending inner rod member 52 which acts in a piston-like manner to transmit physical movement in response to an electrical signal received by the transducer 50. The  
15 transducer 50 is of the type typically having a coil 56 and an armature 58 which is movable in response to a changing magnetic flux within the coil 56. An outer tube member 60 is attached to the transducer outer case 62 of transducer 50 to provide support and protection  
20 to inner rod member 52. The connective means 54 is provided at the outer junction of inner rod member 52 and outer tube member 60 and provides a hermetic seal therebetween.

25 Referring specifically to Figure 6, the connective means 54 is shown in greater detail. The connective means 54 includes an accordion shaped bellows member 64. The bellows member 64 is affixed to the outer tube member 60 in an appropriate manner such as by providing a continuous weld 66 around the periphery of the bellows member and outer tube member end.  
30 The bellows member 64 is provided with a plurality of "U" shaped grooves 68 to give the side wall of the cylindrical bellows member a corrugated configuration. The material of the bellows member is either gold  
35 plated nickel or other biocompatible metal having sufficient strength and flexibility to provide a hermetic seal while still being flexible enough to

allow axial movement of the inner rod member 52. As shown in Fig. 6, the inner rod 52 can be welded to the outer end of the bellows member 64 as shown at 70. Furthermore, hook 22 as shown in Fig. 3 or any other sound transmitting or receiving member may be added as is desired to provide the necessary coupling between the transducer and the human ear.

Strictly by way of example, the bellows member 64 may have an outside diameter (OD) of approximately 0.7 mm and an inside diameter (ID) of 0.4 mm and have a wall thickness of approximately .012 to .015 mm. It is desirable that the spring rate of the corrugated bellows should be less than the respective spring rates of all other components of the transducer 50 or the ossicles of the middle ear.

In another embodiment, it may be desirable to use a flexible hollow tube member in place of the inner tube member 52. The hollow tube member would have at least one end sealed to maintain a hermetically sealed transducer. The hollow tube member would be attached to the armature 58 and bellows member 64 in the same manner as inner rod member 52.

Figure 1 illustrates one use of the invention wherein sound pick-up mechanism 10 is positioned within the middle ear cavity. The manner of attaching the sound pick-up mechanism 10 and sound delivery mechanism 12 within the ear cavity is not shown, however, it is envisioned that such mechanisms will be supported by fixation rods or otherwise secured in the patients bone and cartilage which surrounds the ear cavity. The sound pick-up mechanism 10 is attached by means of hook 22 to the malleus 72. The sound delivery mechanism 12 is also shown positioned within the cavity. The sound delivery mechanism 12 is attached to the auditory system by means of rigid rod 28 which contacts the head of the stapes 76. As illustrated, the ossicular chain is disarticulated by disconnecting two of the ossicular

5 bones, such as at the incudostapedeal joint. In some cases, it may be necessary to remove the incus 78 to provide space and so as not to interfere with movement of the stapes now under control of sound delivery mechanism 12. The sound pick-up and delivery mechanisms may be installed by performing the appropriate surgical approach such as an atticotomy or mastoidectomy. The opening illustrated in Figure 2 at 80 may then be used to receive the sound reinforcement and processing package 34, with either the secondary coil 10 82 or battery 40 being positioned immediately beneath the skin.

15 In use, the sound pick-up and delivery mechanisms as illustrated in Figs. 1, 3 and 5 works as follows: Sounds enter the ear canal 84 and impinge upon the tympanic membrane 86, causing it to vibrate. The tympanic membrane, being attached to the malleus 20 72, thus imparts vibratory movement to the malleus. In a normal ear this movement of the malleus is transmitted through the incus 78 to the stapes 76. However, since the incus and stapes have been disarticulated, this movement is no longer communicated through the stapes. Instead, movement of the malleus acts through hook 22 to vibrate the inner rod member 18 of transducer 25 14 (see Fig. 3). Vibration of the inner rod member 18 transmits vibratory action to transducer armature 58 (Fig. 5). Coil 56 of transducer 14 converts the mechanical vibratory signal into electrical signals which are transmitted via wires 36 to the sound reinforcement and process package 34. 30

35 In many cases, the electrical signals will be amplified and may be additionally filtered to emphasize or de-emphasize various frequency ranges by the processing package 34 in accordance with the needs of the particular patient. Either analog or digital processing of the electrical signals can be employed. Using digital techniques, the electronic signal processing

can be quite precise and quite frequency-selective, as needed. The objective of this signal processing is to provide a signal which compensates for deficiencies in the patient's hearing, in an effort to provide as much hearing as is possible.

After electronic amplification and signal processing, the electrical signal is fed through wires 38 to the sound delivery mechanism 12 which converts the electrical signals back into a vibratory mechanical signal via the coil 56 and armature 58 of transducer 24. These vibrations are then transmitted via inner rod member 28 to the middle ear bone (i.e. the stapes 72) of choice for transmission of the sound waves to the patient's cochlea.

Figs. 2 and 4 illustrate another use of the invention wherein sound pick-up mechanism 10 is attached by means of hook 22 to the incus 78 instead of the malleus 72. Otherwise the sound pick-up and delivery mechanisms 10 and 12, respectively, operate to transmit sound to the stapes 76 in the same manner as specified above.

Referring now to Fig. 7, another use of the invention is illustrated wherein sound pick-up mechanism 10 is positioned so that the outer end 92 of inner rod member 18 abuts the ear canal as shown at 88. Sound pick-up mechanism is anchored within cartilage 90 to securely affix the mechanism in place. Sound waves entering the ear canal will cause the outer end 92 of rod member 18 of transducer 10 to vibrate thus transmitting such sound waves via inner rod member 18 through the outer intermediate tube member 16 to transducer 14 in the same manner as described above.

Yet, another use of the invention allows the ossicular chain to remain intact by attaching the tip 32 of inner rod 28 of sound delivery mechanism 12 to either the malleus 72 or the incus 78 without removing any of the middle ear bones. This permits the hearing

aid system of the present invention to act as a supplementary means in addition to the patient's residual hearing which is maintained by keeping the ossicular chain intact.

5                   From the foregoing it will be seen that the present invention provides a solution to the problem of hermetically sealing an acoustic coupler or transducer for transmitting sound waves within the middle ear cavity. And, while the invention has been illustrated  
10 in an application utilizing both sound pick-up and sound delivery transducers, the invention may be adapted for other uses as well. For example, the sound delivery transducer may be adapted to transmit its signal directly into the cochlea. Alternatively,  
15 instead of utilizing an electromechanical transducer, the invention will use some other type of transducer or vibratory device capable of creating mechanical vibrations from auditory sound waves. Accordingly, it should be understood that the present invention is  
20 capable of certain modifications without departing from the spirit of the invention as set forth in the appended claims.

25

30

35



Case No. 31,168

WHAT IS CLAIMED IS:

1. A hermetically sealed acoustic mechanism for a partially implanted hearing aid system including an electromechanical transducer, comprising:

at least one moving member in said transducer to transmit mechanical vibrations to a middle ear component for producing the perception of sound in the ear;

a bellows member for hermetically sealing the vibrating joint between the transducer and said moving member;

means for attaching said bellows member to said transducer in a hermetic fashion; and

means for attaching said bellows member to said moving member in a hermetic fashion.

2. The acoustic mechanism of Claim 1 wherein said electromechanical transducer includes a microphone.

3. The acoustic mechanism of Claim 1 where said electromechanical transducer includes a receiver.

4. The acoustical mechanism of Claim 1 wherein said moving member is a solid rod.

5. The acoustic mechanism of Claim 1 wherein said moving member is a hollow tube with at least one sealed end.

6. The acoustic mechanism of Claim 1 wherein the bellows member is manufactured out of gold plated nickel.

7. The acoustic mechanism of Claim 1 wherein the bellows member is manufactured out of a biocompatible gold alloy.

8. The acoustic mechanism of Claim 1 wherein the bellows member is manufactured out of a

biocompatible material that will provide a hermetic seal.

9. The acoustic mechanism of Claim 1 wherein the bellows member further includes flanges provided at each end to provide means for attachment of said bellows member to the moving member and transducer case.

10. An implantable hearing aid for the middle ear comprising:

signal processing means including signal processing circuitry and power means;

a sound pick-up transducer means electrically connected to said signal processing means, said transducer means having an outer casing and at least one movable member;

a hermetically sealed bellows member having first and second ends, and a generally cylindrical side wall, the first and second ends having flanges thereon, the side wall having a plurality of corrugations provided therein to allow the second end of said bellows member to move independently of the first end of said bellows member;

first coupling means for hermetically connecting the flange of said first end of the bellows member to said transducer casing; and

second coupling means for hermetically connecting the flange of said second end of said bellows member to said movable member whereby sound vibrations in said first middle ear member are transmitted from said moveable transducer member to said sound pick-up transducer means for generation of a resultant signal means by said signal processing means.

Smart & Biggar  
Ottawa, Canada  
Patent Agents

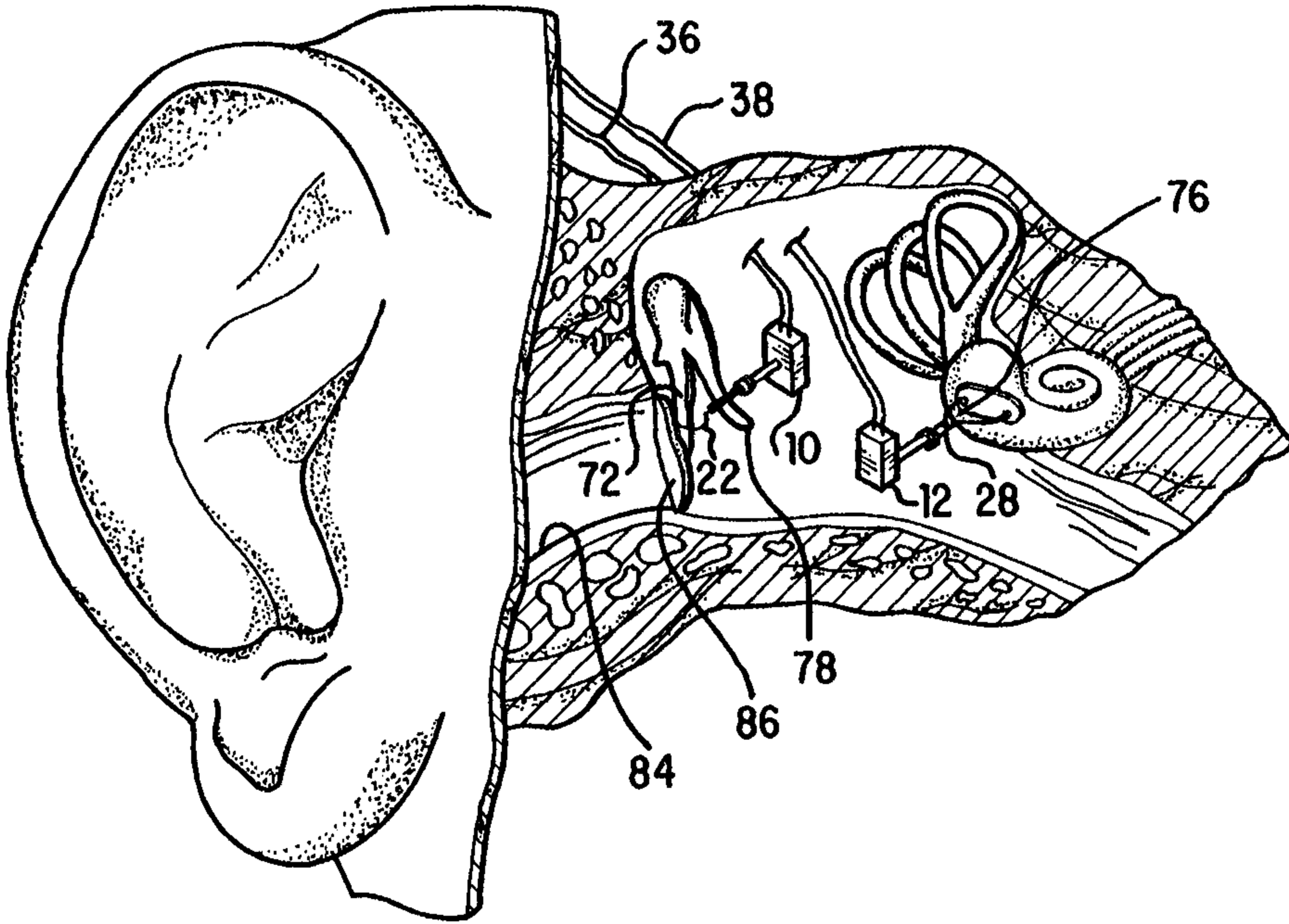

FIG. 1

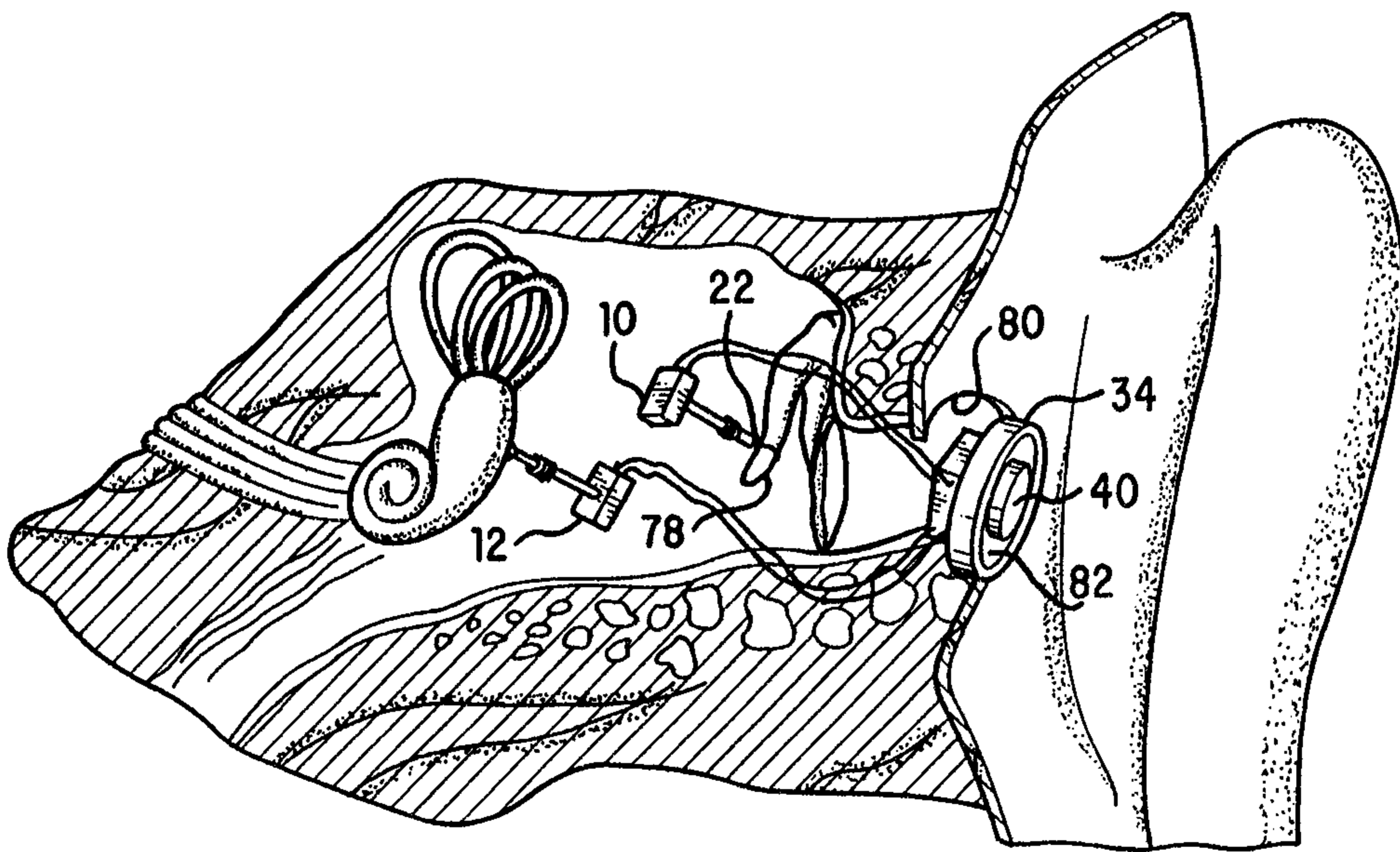

FIG. 2

*Patent Agents  
Smart & Higgins*

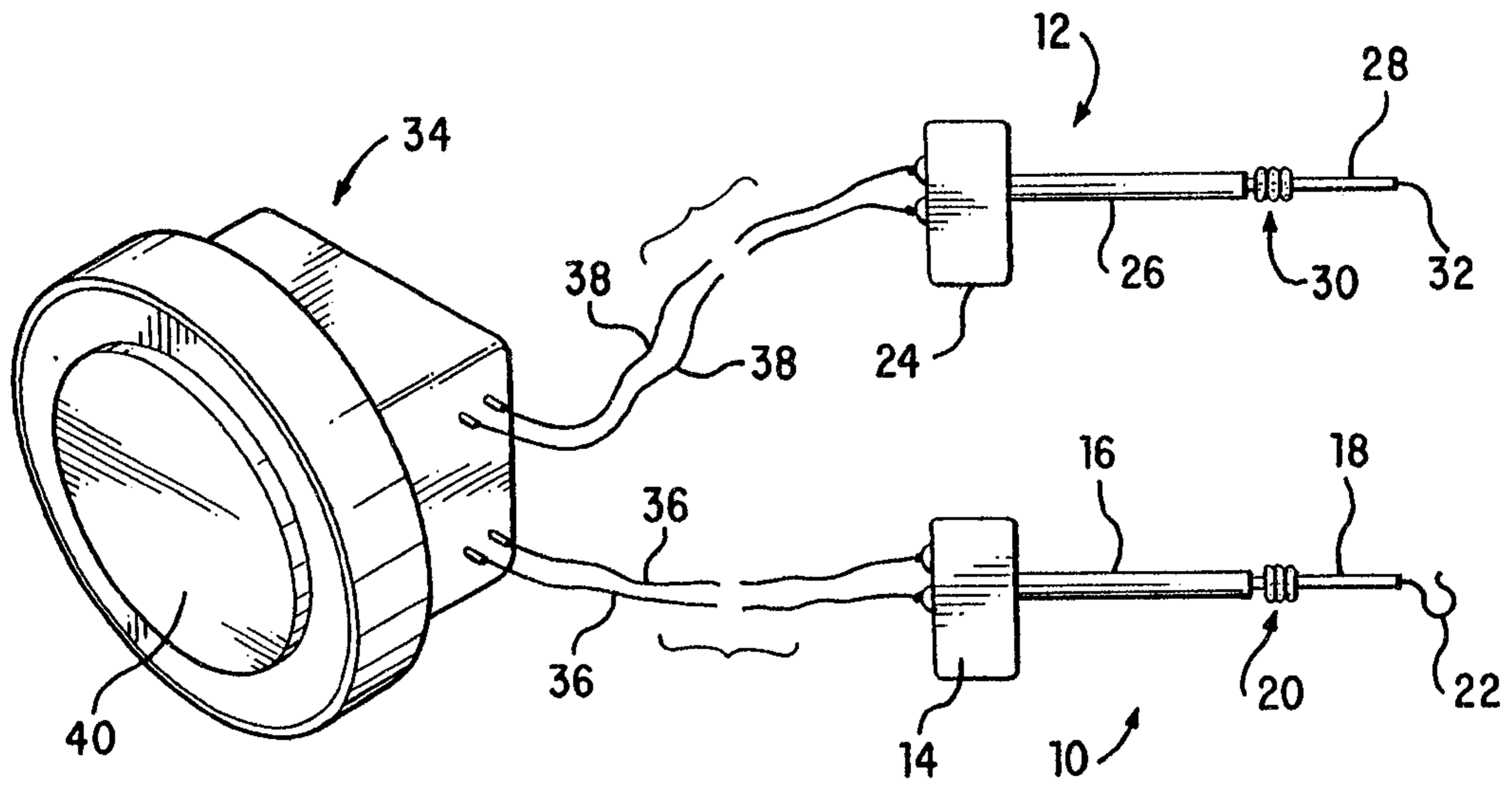

FIG. 3

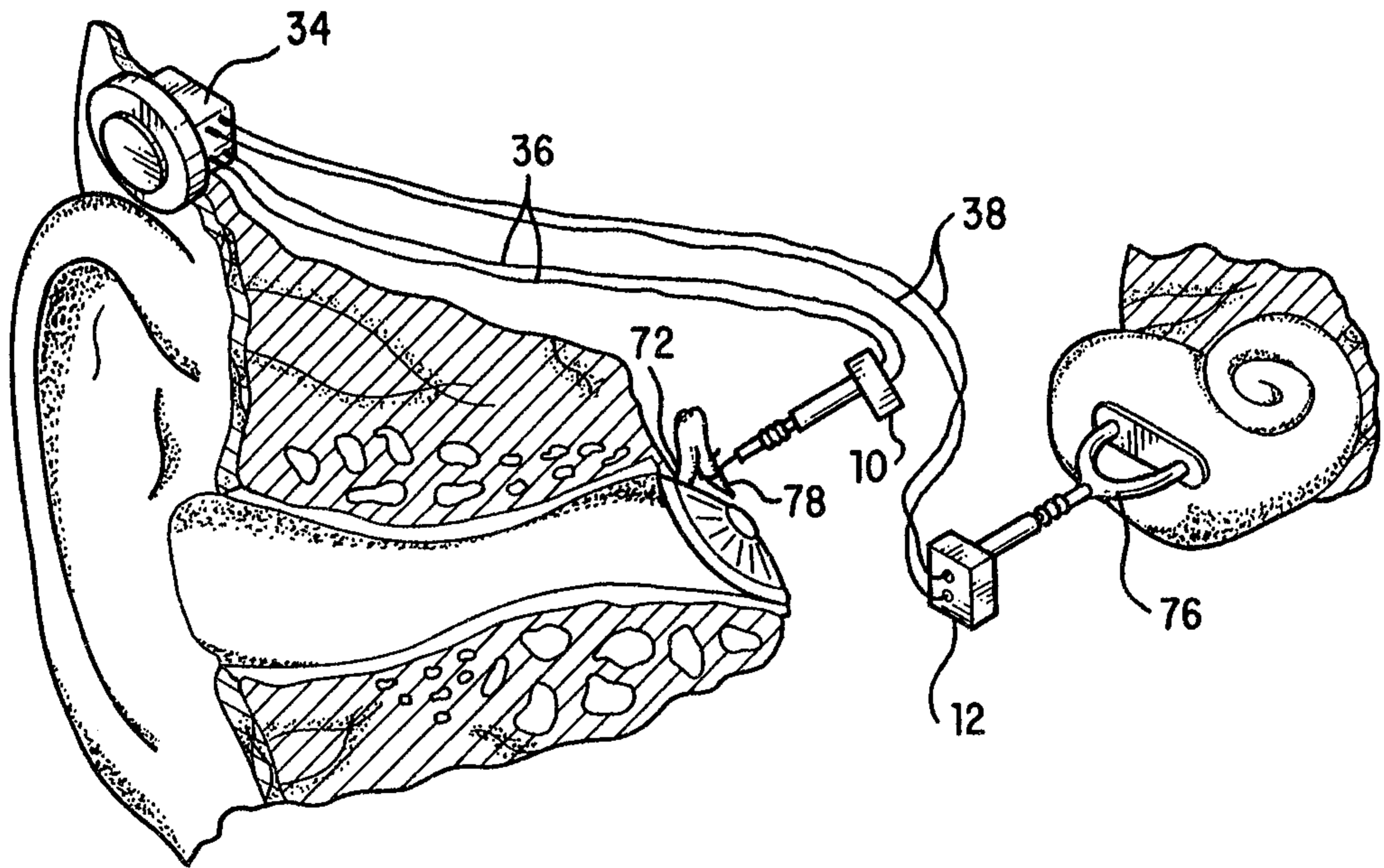

FIG. 4

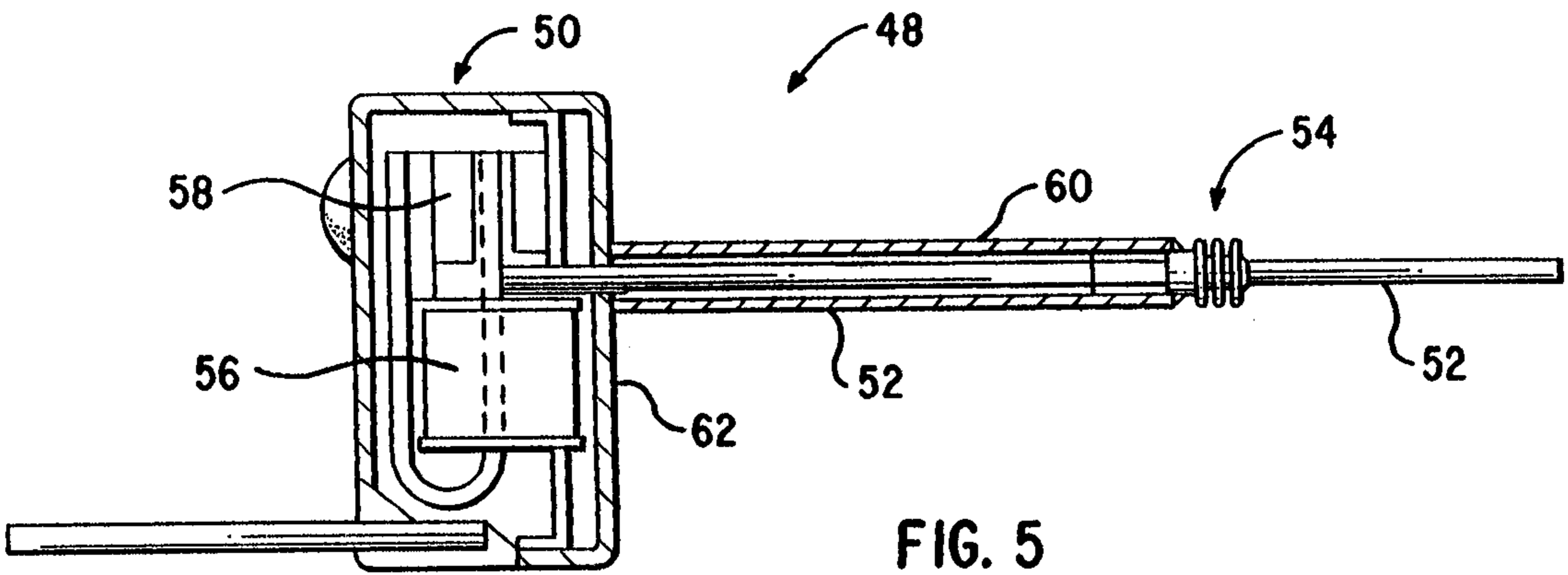

FIG. 5

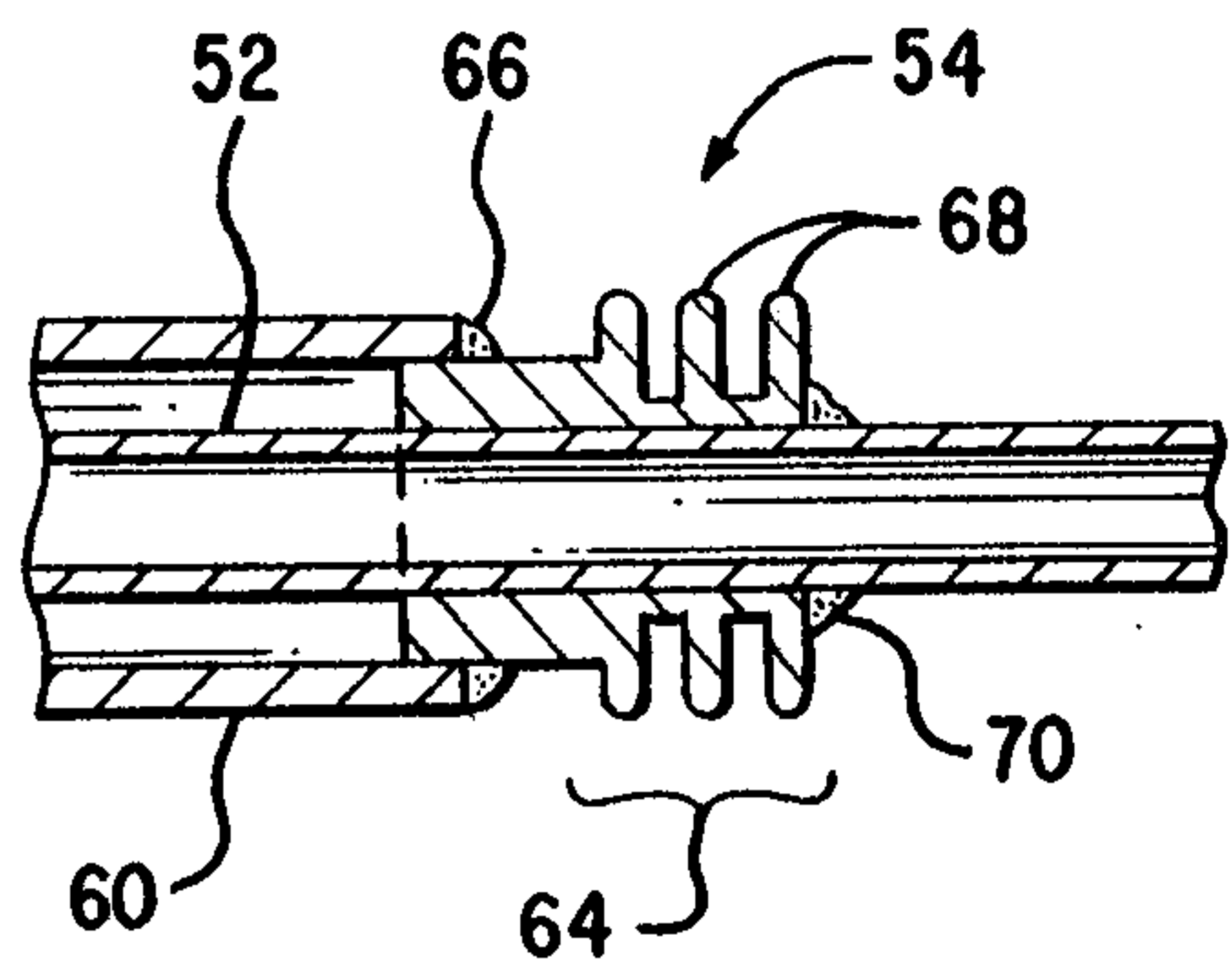

FIG. 6

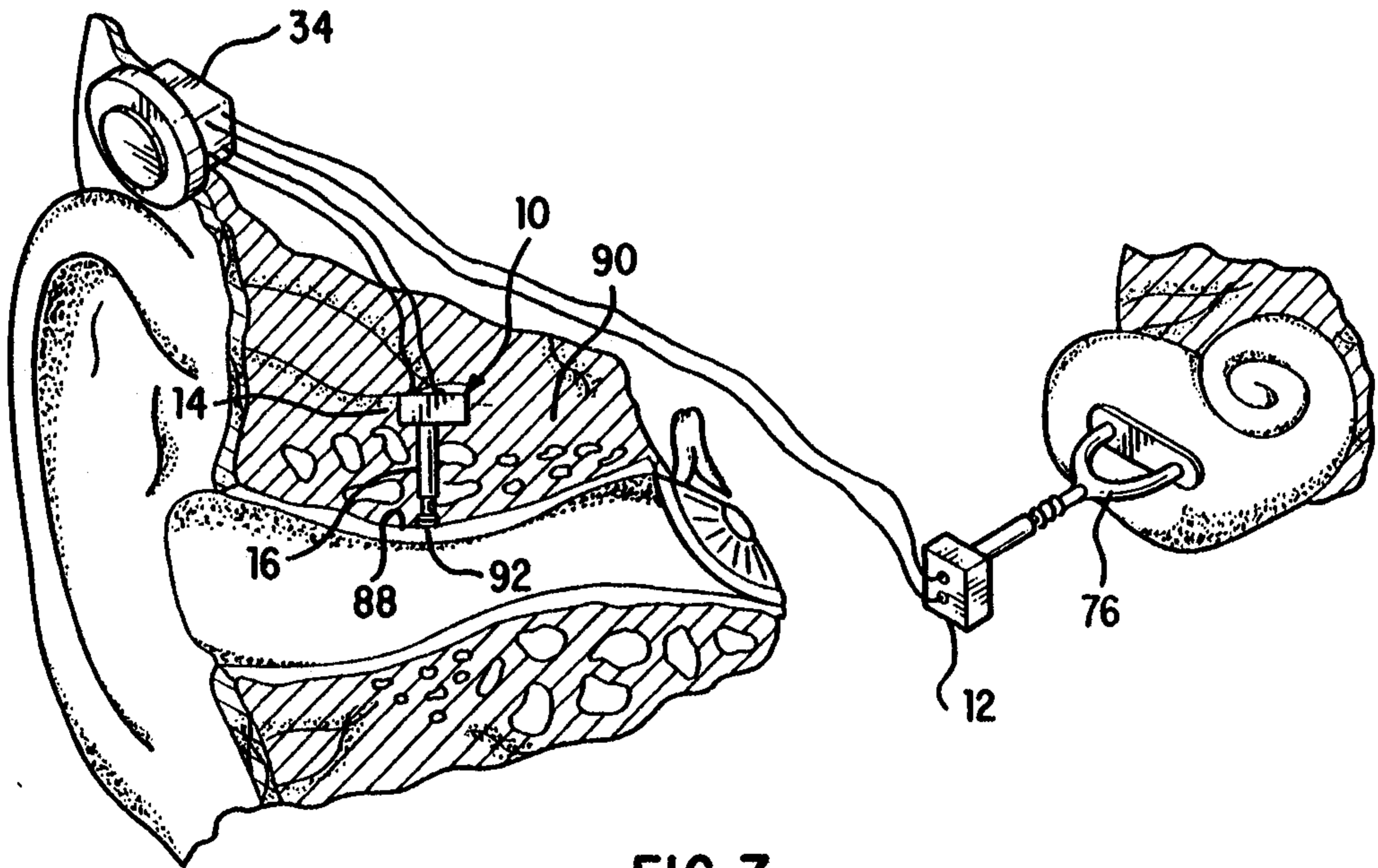

FIG. 7

*Patented*  
*Sept. 19, 1942*

