

(43) Date of A Publication 09.08.1995

(21) Application No 9502300.8

(22) Date of Filing 01.04.1992

Date Lodged 04.02.1995

(62) Derived from Application No. 9207100.0 under Section 15(4) of the Patents Act 1977

(71) Applicant(s)  
Cego Limited

(Incorporated in the United Kingdom)

Western Road, Silver End, WITHAM, Essex, CM8 3QB,  
United Kingdom

(72) Inventor(s)  
Melvin John Hutton  
John Kelly

(51) INT CL<sup>6</sup>  
E05C 9/18 9/04

(52) UK CL (Edition N )  
E2A AMXJ A160 A162 A420 A421 A508

(56) Documents Cited  
None

(58) Field of Search  
UK CL (Edition N ) E2A AAK AMXJ  
INT CL<sup>6</sup> E05C 9/04 9/18

(74) Agent and/or Address for Service  
Mathisen Macara & Co  
The Coach House, 6-8 Swakeleys Road, Ickenham,  
UXBRIDGE, Middlesex, UB10 8BZ, United Kingdom

(54) ESPAGNOTETTE TYPE MECHANISM

(57) A door or window fastener in which two slidably mounted locking bars (1, 2) are driven by an operating mechanism (3) simultaneously in opposite directions to fasten or unfasten the door or window comprises a pair of locking mechanisms (33, 34) having locking members (42) which are pivotally mounted in fixed housings (35) so that the locking members (42) are engaged by the locking bars (1, 2) and caused to rock to a projecting, fastening position when one of the bars is moved in one direction and the other bar is moved simultaneously in the other direction, and the locking members (42) are engaged by the locking bars and caused to rock back to a retracted, unfastening position when the bars are moved in the opposite directions, the locking bars (1, 2) overlying the locking member housings (35) and being provided with actuator slots (44) through which the locking members are arranged to move, each locking member being engaged by one end (46) of the respective actuator slot (44) to move it to the fastening position, and by the other end (45) of the actuator slot (44) to move it back to the unfastening position.

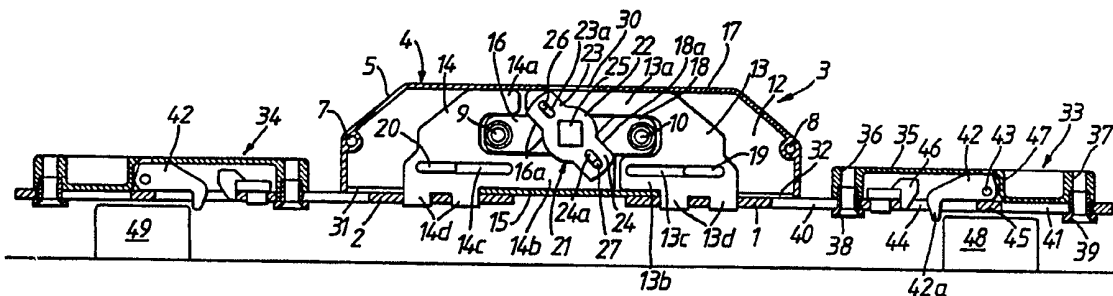

Fig.1.

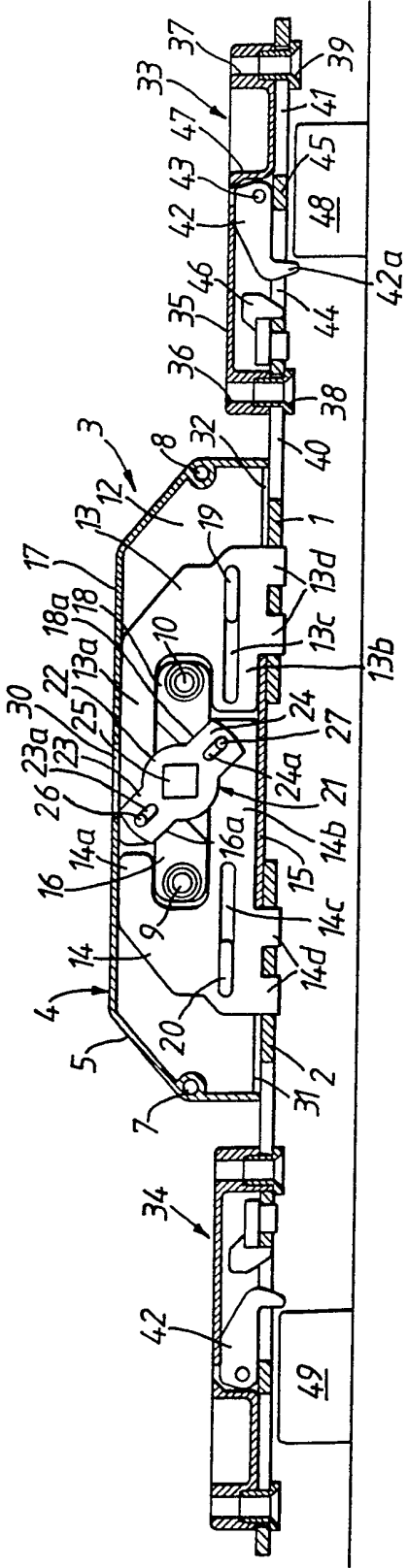

Fig. 1.

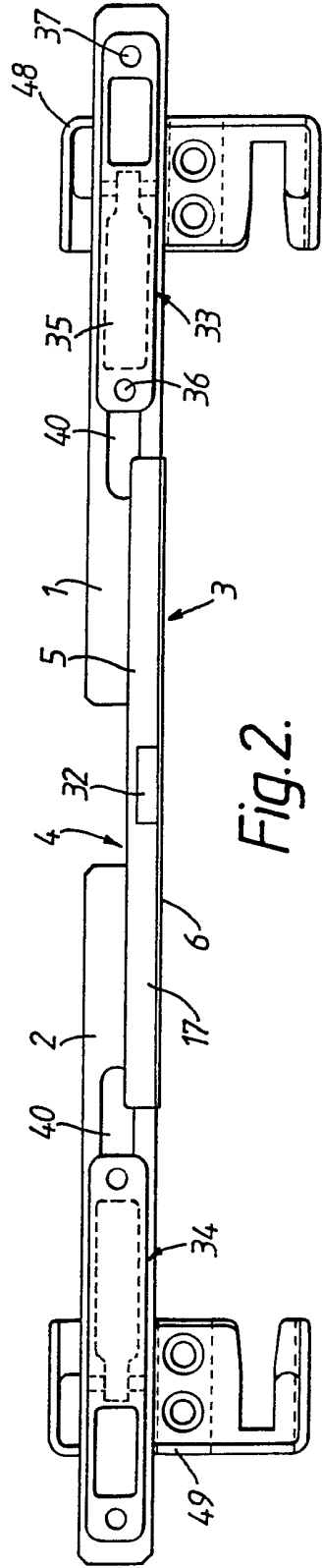

Fig. 2.

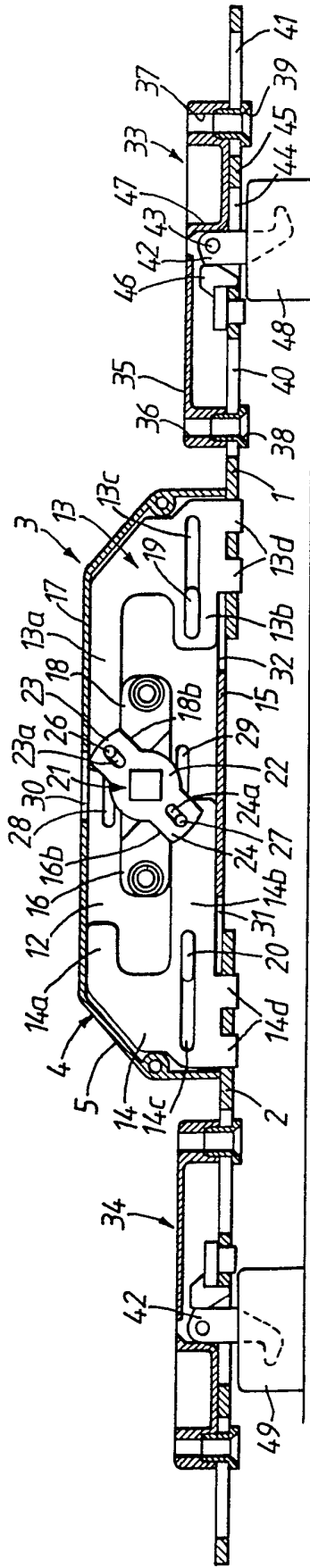

Fig. 3.

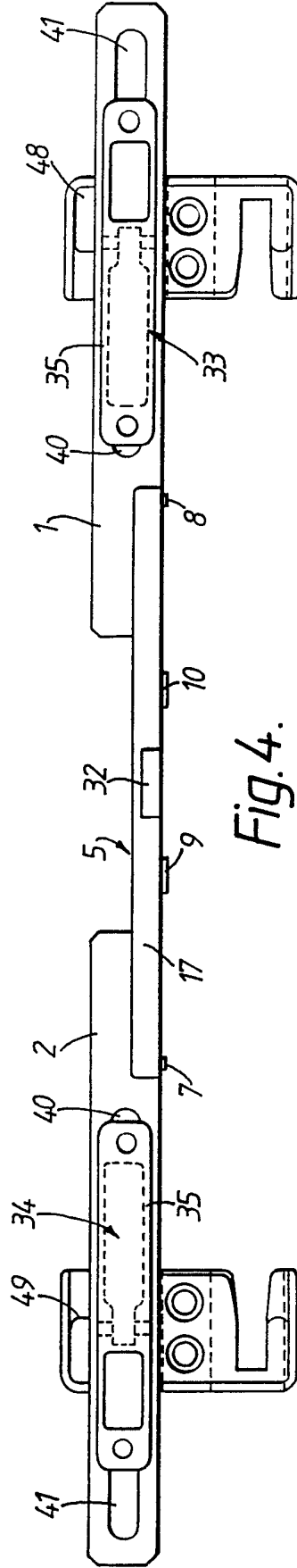

Fig. 4.

DOOR OR WINDOW FASTENER

The invention relates to door or window fasteners of the type in which two slidably mounted locking bars are driven by an operating mechanism simultaneously in opposite directions to fasten or unfasten the door or window.

One example of such a fastener is the well known espagnolette fastener in which the locking bars are mounted on the openable part of the door or window and the ends of the bars are arranged to engage in keepers provided on the fixed frame when the bars are driven to fasten the door or window in the closed position. In one variant of this type of fastener the bars carry perpendicularly projecting headed locking pins which are arranged to engage in keyhole shaped slots provided in the fixed frame. Alternatively, the pins may be provided on the frame and the slots in the locking bars.

In accordance with the invention, the locking bars of the fastener are arranged to operate respective locking members which are pivotally mounted in fixed housings such that the locking members are engaged by the locking bars and caused to rock to a projecting, fastening position when one of the bars is moved in one direction and the other bar is moved simultaneously in the other

direction, and the locking members are engaged by the locking bars and caused to rock back to a retracted, unfastening position when the bars are moved in the opposite directions, the locking bars overlying the locking member housings and being provided with actuator slots through which the locking members are arranged to move, each locking member being engaged by one end of the respective actuator slot to move it to the fastening position, and by the other end of the actuator slot to move it back to the unfastening position.

The locking members are preferably moved to the fastening position when the locking bars are moved away from each other. In the fastening position, the locking members, which may be in the form of hooks, are arranged to engage in corresponding recesses or sockets provided in or on the fixed frame of the door or window facing the locking bars.

In a preferred embodiment, the locking bars are provided with further slots forming guide slots through which project headed guide pins carried by the locking member housings.

One embodiment of a fastener in accordance with the invention will now be described, by way of example, with reference to the accompanying diagrammatic drawings, in

which:-

Figure 1 is a part sectional, side elevation of the fastener and its operating mechanism in the unfastening position;

Figure 2 is a plan view of the fastener as shown in Figure 1;

Figure 3 is a view similar to that of Figure 1, but showing the fastener and operating mechanism in the fastening position; and

Figure 4 is a plan view of the fastener as shown in Figure 3.

The fastener illustrated in the drawings comprises two longitudinally slidable, flat locking bars 1 and 2 which are disposed in line with each other in a common plane and which are connected at their proximal ends to an operating mechanism 3 for moving the locking bars 1 and 2 away from each other to engage the fastener and back towards each other to release the fastener.

The operating mechanism 3 comprises an elongate, shallow casing 4 formed by a casing shell 5 and a cover plate 6 which is secured to the shell 5 by means of bolts, screws

or rivets received in tubular sockets 7,8,9 and 10 carried by the casing shell. The casing 4 overlies the proximal end portions of the locking bars 1 and 2, bridging the gap 11 between the bars, and is disposed with the median plane of the casing (i.e. the plane parallel to the cover 6 and the opposite wall 12 of the casing shell 5) substantially perpendicular to the plane of the locking bars 1 and 2. As can be seen from Figures 2 and 4, the width of the casing 4 in the direction perpendicular to its median plane is much less than the width of the locking bars 1 and 2, and the casing 4 is offset to one side of the longitudinal centre line of the bars so that the side wall defined by the cover 6 of the casing lies substantially in line with one side edge of the bars.

The operating mechanism 3 also comprises two slide plates 13 and 14 which are slidably mounted in a common plane within the casing 4 so that each is movable longitudinally between a position at a respective end of the casing 4 as shown in Figure 3 and a nearly meeting position as shown in Figure 1, the slide plates 13,14 being guided linearly as described below. Each slide plate 13,14 has a pair of spaced, unequal length limbs 13a,13b and 14a,14b extending in a longitudinal direction towards the other plate. The longer limb 14b of the slide plate 14 lies adjacent the longitudinal edge wall

15 of the casing which overlies the proximal end portions of the locking bars 1 and 2, and extends closely between this edge wall 15 and a guide block 16 which is fixed to the casing side wall 12 in the region of the socket 9. The shorter limb 14a of the slide plate 14 lies adjacent the longitudinal edge wall 17 of the casing opposite the edge wall 15 and, in the meeting position of the slide plates shown in Figure 1, extends closely between the edge wall 17 and the guide block 16. Conversely, the longer limb 13a of the slide plate 13 lies adjacent the longitudinal edge wall 17 of the casing and extends between this edge wall 17 and a guide block 18 carried by the casing side wall 12 in the region of the socket 10, whereas the shorter limb 13b lies adjacent the longitudinal edge wall 15 and extends closely between this wall and the guide block 18 when the slide plates are in the meeting position. Each slide plate 13,14 is also provided with a longitudinally extending guide slot 13c,14c for receiving a guide element 19,20 respectively carried by the casing side wall 12.

The operating mechanism 3 further comprises a drive member 21 positioned between the two guide blocks 16 and 18, the drive member 21 having a central hub portion 22 and two diametrically opposite arms 23 and 24 extending radially from the hub portion. The hub portion 22 has a square central aperture 25 for receiving the square



sectioned spindle of an operating handle (not shown), and each of the arms 23 and 24 is provided with a radially directed slot 23a,24a. The slot 23a receives a pin 26 carried by the longer limb 13a of the slide plate 13, and the slot 24a receives a pin 27 carried by the longer limb 14b of the slide plate 14, whereby the slide plates 13 and 14 are connected to the drive member 21. The drive member 21 is rotatable by means of the operating handle between a first limit position defined by stop surfaces 16a and 18a which are provided on the guide blocks 16,18 and are engaged by the arms 23 and 24 of the drive member 21 as shown in Figure 1, and a second limit position in which further stop surfaces 16b and 18b provided on the guide blocks 16 and 18 are engaged by the arms 23 and 24 of the drive member as shown in Figure 3. Rotation of the drive member 21 between the two limit positions causes the slide plates 13 and 14 to slide simultaneously in opposite directions as a result of the pin and slot connections 26,23a and 27,24a, the plates moving to the meeting position shown in Figure 1 when the drive member is moved to its first limit position, and moving to the spaced position as shown in Figure 3 when the drive member 21 is moved to the second limit position.

It will be noted that the pins 26 and 27 carried by the slide plates 13 and 14 also project into a pair of longitudinally extending guide slots 28,29 respectively

provided in the casing side wall 12 as can be seen in Figure 3. It will also be noted that in order to reduce the height of the casing 4 (i.e. in the direction perpendicular to the plane of the locking bars 1 and 2), the edge wall 17 is provided with a slot 30 to allow the free end of the arm 23 of the driving member 21 to pass unhindered as the driving member moves between its two limit positions.

Each slide plate 13,14 has a pair of lugs 13d,14d projecting from it through a respective slot 31,32 in the longitudinal side edge 15 of the casing 4. The lugs 13d of the slide plate 13 are received in a pair of aligned holes in the proximal end portion of the locking bar 1 and are firmly fixed in the holes in any suitable manner so as to secure the locking bar 1 and the slide plate 13 together. Similarly, the lugs 14d of the slide plate 14 are received and fixed in aligned holes in the proximal end portion of the locking bar 2 so as to secure the locking bar 2 and the slide plate 14 together.

Accordingly, the locking bars 1 and 2 are driven simultaneously in opposite directions towards or away from each other when the slide plates 13 and 14 are similarly driven by the drive member 21 by turning the operating handle.

In use, the operating mechanism and the locking bars of the fastener will usually be fitted to the edge face of the openable part of a window or door opposite the hinged edge, the operating mechanism 3 being recessed into the frame of the openable part. In the case of a window in which the frame of the vent is formed from extruded sections made of aluminium or plastics such as UPVC, the locking bars may be fitted into the "euro-groove" of the frame, with the operating mechanism 3 projecting through a slot cut in the base of the groove. If preferred, however, the fastener may be located close to the inside face of the frame, the extremely slim construction of the operating mechanism 3 enabling the mechanism to fit easily into the inner upstand of the frame.

The movement of the locking bars 1 and 2 away from and back towards each other is arranged to operate a pair of locking mechanisms 33 and 34 associated with the locking bars 1 and 2 respectively. The two locking mechanisms 33 and 34 are identical to each other, and for convenience only one of the mechanisms 33 will be described.

As shown, the locking mechanism 33 comprises an elongate housing 35 disposed on the same side of the locking bar 1 as the operating mechanism 3, the housing 35 being aligned with the locking bar and having a pair of fixing holes 36 and 37 at opposite ends by which the housing can

be fixed in the desired position to the openable part of the window or door by screws or other suitable headed fixing elements when the fastener is installed. In addition to securing the housing 35 in position, the fixing elements serve to secure in place a pair of flanged guide sleeves 38 and 39 which are aligned with the bores 36 and 37 respectively and project through respective longitudinally spaced guide slots 40 and 41 in the locking bar 1. The flanged heads of the guide sleeves 38 and 39 overlie the locking bar 1 on opposite sides of the guide slots 40 and 41 and serve to maintain the locking bar in close sliding relation over the housing 35 as the locking bar is moved longitudinally forwards and backwards by the operating mechanism.

The locking mechanism 33 further comprises a hook shaped locking pawl 42 which is pivotally mounted on a transverse pivot pin 43 so that it is pivotable between a retracted, inoperative position within the housing 35 as shown in Figure 1, and an operative position in which it projects substantially perpendicularly from the housing as shown in Figure 3 through a longitudinal actuator slot 44 provided in the locking bar 1 between and in alignment with the guide slots 40 and 41. When the locking bar 1 is withdrawn towards the other locking bar 2 by the operating mechanism 3, the distal end of the actuator slot 44 engages the locking pawl 42 and causes it to rock

back into the housing 35 to its retracted position as shown in Figure 1. In this position, the portion 45 of the locking bar 1 between the slots 44 and 41 overlies the pivoted end of the locking pawl to hold the locking pawl in the retracted position. It will be noted, however, that in the retracted position the hooked end 42a of the locking pawl still projects slightly through the actuator slot 44. Thus, when the locking bar 1 is driven by the operating mechanism 3 in a direction away from the other locking bar 2, a driver cam 46 carried by the locking bar 1 at the proximal end of the actuator slot 44 engages the hooked end 42a of the locking pawl as the portion 45 moves clear of the pivoted end thereof. Interaction between the driver cam 46 and the locking pawl 42 as the locking bar 1 is moved further away from the other bar 2 then causes the locking pawl 42 to rock towards and into the operative position shown in Figure 3. In this position, the locking pawl 42 is held firmly between the driver cam 46 and an abutment wall 47 of the housing 35 lying substantially perpendicularly to the plane of the locking bar.

In its operative position, the locking pawl 42 of each locking mechanism 33,34 engages a respective keeper member 48,49 which is mounted on the fixed surrounding frame of the window or door, thereby fastening the door or window and preventing it from being opened until the

operating handle is turned to move the locking bars back towards each other, thereby disengaging the locking pawls 42 from the keepers 48 and 49 and moving them back to the inoperative, retracted position.

The fastener described above is also described and illustrated in our application Serial No. 2265935, which claims an operating mechanism for a door or window fastener in which two slidably mounted locking bars are driven by the operating mechanism simultaneously in opposite directions to fasten or unfasten the door or window, comprising a drive member which is intended to be driven by the spindle of an operating handle so as to turn with the handle, a first linearly guided reciprocable slide plate which is connected to the drive member by a first pin and slot connection, a second linearly guided reciprocable slide plate which is connected to the drive member by a second pin and slot connection at a position substantially diametrically opposite the first pin and slot connection with respect of the axis of rotation of the drive member so that the two slide plates are caused to move linearly in opposite directions to each other whenever the drive member is rotated by turning the operating handle, and a casing in which the drive member and the slide plates are housed, the casing mounting a pair of stop members which limit the turning of the drive member in each direction, and

hence the travel of the slide plates, and which also act as guide blocks for the slide plates, each slide plate having two parallel spaced limbs capable of receiving a respective one of the two guide blocks closely between them, one of the limbs lying closely adjacent one of the edge walls of the casing, and the other limb lying closely adjacent the opposite edge wall of the casing.

CLAIMS

1. A door or window fastener in which two longitudinally slidably mounted locking bars are driven by an operating mechanism simultaneously in opposite directions to fasten or unfasten the door or window, the locking bars being arranged to operate respective locking members which are pivotally mounted in fixed housings such that the locking members are engaged by the locking bars and caused to rock to a projecting, fastening position when one of the bars is moved in one direction and the other bar is moved simultaneously in the other direction, and the locking members are engaged by the locking bars and caused to rock back to a retracted, unfastening position when the locking bars are moved in the opposite directions, the locking bars overlying the locking member housings and being provided with actuator slots through which the locking members are arranged to move, each locking member being engaged by one end of the respective actuator slot to move it to the fastening position, and by the other end of the actuator slot to move it back to the unfastening position.

2. A fastener according to claim 1, in which the locking members are moved to the fastening position when the locking bars are moved away from each other.



3. A fastener according to claim 1 or claim 2, in which the locking members are in the form of hooks.

4. A fastener according to any one of claims 1 to 3, in which said other end of each actuator slot overlies a portion of the respective locking member when the locking member is in its retracted position to hold the locking member firmly in the retracted position.

5. A fastener according to any one of the preceding claims, in which the locking bars are provided with further slots forming guide slots through which project headed guide pins carried by the locking member housings.

6. A fastener according to claim 1, substantially as described with reference to the accompanying drawings.

(0943U)

**Relevant Technical Fields**

(i) UK Cl (Ed.N) E2A (AAK, AMXJ)

(ii) Int Cl (Ed.6) E05C 9/04, -9/10

**Databases (see below)**

(i) UK Patent Office collections of GB, EP, WO and US patent specifications.

(ii)

Search Examiner  
 A ANGELE

Date of completion of Search  
 2 MAY 1995

Documents considered relevant following a search in respect of Claims :-  
 ALL

**Categories of documents**

- |   |   |
|---|---|
| <b>X:</b> Document indicating lack of novelty or of inventive step.   | <b>P:</b> Document published on or after the declared priority date but before the filing date of the present application.        |
| <b>Y:</b> Document indicating lack of inventive step if combined with one or more other documents of the same category. | <b>E:</b> Patent document published on or after, but with priority date earlier than, the filing date of the present application. |
| <b>A:</b> Document indicating technological background and/or state of the art.   | <b>&amp;:</b> Member of the same patent family; corresponding document.   |

Category	Identity of document and relevant passages	Relevant to claim(s)
	NONE	

**Databases:**The UK Patent Office database comprises classified collections of GB, EP, WO and US patent specifications as outlined periodically in the Official Journal (Patents). The on-line databases considered for search are also listed periodically in the Official Journal (Patents).