



US00D870730S

(12) **United States Design Patent**  
**Wang**

(10) **Patent No.:** **US D870,730 S**

(45) **Date of Patent:** **\*\* Dec. 24, 2019**

(54) **OMNIDIRECTIONAL MOTION SIMULATOR**

FOREIGN PATENT DOCUMENTS

(71) Applicant: **Hangzhou Virtual And Reality Technology Co., LTD.**, Hangzhou (CN)

WO WO-2010089618 A2 \* 8/2010 ..... A63B 69/0035

(72) Inventor: **Bo Wang**, Hangzhou (CN)

OTHER PUBLICATIONS

(73) Assignee: **HANGZHOU VIRTUAL AND REALITY TECHNOLOGY CO., LTD.**, Hangzhou (CN)

VR Treadmills. (Design—© Questel) orbit.com. [online PDF] 17 pgs. Print Dates Range Jul. 1, 2015 through Jul. 2, 2019. [Retrieved on Sep. 10, 2019] <https://sobjprd.questel.fr/export/QPTUJ214/pdf2/b50f869b-0ef6-45e3-9b4c-fe425d4f97cd-223842.pdf>.\*

(\*\*) Term: **15 Years**

(Continued)

(21) Appl. No.: **29/646,143**

(22) Filed: **May 2, 2018**

(30) **Foreign Application Priority Data**

*Primary Examiner* — Marie D. Fast Horse

Mar. 14, 2018 (CN) ..... 2018 3 0093797

(74) *Attorney, Agent, or Firm* — Gokalp Bayramoglu

(51) **LOC (12) Cl.** ..... **14-02**

(52) **U.S. Cl.**  
USPC ..... **D14/388**; D21/324; D21/669; D21/828;  
D14/356

(57) **CLAIM**

(58) **Field of Classification Search**

The ornamental design for an omnidirectional motion simulator, as shown and described.

USPC ..... D14/419, 356, 388, 389, 399, 400, 402, D14/408, 432, 433, 439, 454, 299, 218, D14/496, 511; D21/324, 333, 669, 671, D21/686–691, 694, 811, 828; D13/164; D25/62, 66; D34/28; D10/87, 88, 91, D10/92, 93; D19/59, 60  
CPC .... A63B 2024/0096; A63B 2069/0037; A63B 2225/093; A63B 2225/50; A63B 2210/50; A63B 2220/10; A63B 2220/12; A63B 2220/40; A63B 2220/805; A63B 2071/0638; A63B 2208/12; A63B 21/0023; A63F 2300/8082; G06F 2203/012; G06F

(Continued)

**DESCRIPTION**

The patent or application file contains at least one drawing executed in color. Copies of this patent or patent application publication with color drawing(s) will be provided by the Office upon request and payment of the necessary fee.

FIG. 1 is a perspective view of an omnidirectional motion simulator showing the new design;  
FIG. 2 is another perspective view thereof;  
FIG. 3 is a front view thereof;  
FIG. 4 is a rear view thereof;  
FIG. 5 is a left side view thereof;  
FIG. 6 is a right side view thereof;  
FIG. 7 is a top view thereof; and,  
FIG. 8 is a bottom view thereof.

(56) **References Cited**

**U.S. PATENT DOCUMENTS**

3,604,722 A \* 9/1971 Boley ..... A63G 1/00  
280/87.01

D275,413 S \* 9/1984 Shroads ..... D21/792  
(Continued)

**1 Claim, 8 Drawing Sheets**  
**(8 of 8 Drawing Sheet(s) Filed in Color)**

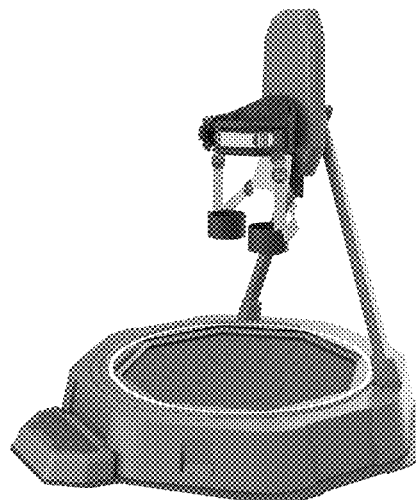

# US D870,730 S

- (58) **Field of Classification Search**  
 CPC ..... 3/011; G06F 3/016; G06F 3/0334; G06F  
 3/0383; A61G 7/1038; A61G 7/1046;  
 A61G 7/1076  
 See application file for complete search history.

D742,972	S *	11/2015	Corrigan	.....	D21/324
9,358,422	B2 *	6/2016	Brontman	.....	A63B 22/0023
D766,239	S *	9/2016	Goetgeluk	.....	D14/356
D787,516	S *	5/2017	Goetgeluk	.....	D14/356
D789,368	S *	6/2017	Goetgeluk	.....	G06F 3/011
					D14/388
D807,445	S *	1/2018	Gettle	.....	D21/686
D840,400	S *	2/2019	Wang	.....	D14/388
2004/0242390	A1 *	12/2004	Williams	.....	A63B 23/0464
					482/146
2005/0156878	A1 *	7/2005	Logue	.....	G06F 3/011
					345/156
2006/0139317	A1 *	6/2006	Leu	.....	G06F 3/011
					345/156
2007/0109259	A1 *	5/2007	Liu	.....	G06F 3/011
					345/156
2008/0280740	A1 *	11/2008	Knecht	.....	A61B 3/113
					482/146
2008/0284725	A1 *	11/2008	Logue	.....	G06F 3/011
					345/156
2009/0111670	A1 *	4/2009	Williams	.....	A63B 23/0464
					482/146
2010/0103093	A1 *	4/2010	Izumi	.....	G06F 3/0334
					345/156
2011/0009241	A1 *	1/2011	Lane	.....	A63B 24/0087
					482/8
2011/0105288	A1 *	5/2011	Susnjara	.....	A63B 21/0004
					482/142
2013/0237378	A1 *	9/2013	Carrell	.....	A63C 17/061
					482/51
2014/0111424	A1 *	4/2014	Goetgeluk	.....	G06F 3/011
					345/156
2015/0092015	A1 *	4/2015	Stafford	.....	G02B 27/017
					348/46
2015/0190713	A1 *	7/2015	Goetgeluk	.....	A63F 13/40
					345/156
2016/0035228	A1 *	2/2016	Cakmak	.....	F41G 3/26
					434/247
2016/0328028	A1 *	11/2016	Khojasteh	.....	G06F 3/0334
2018/0157318	A1 *	6/2018	Wang	.....	A63B 71/0054

- (56) **References Cited**  
 U.S. PATENT DOCUMENTS

5,149,043	A *	9/1992	Grundmann	.....	A47B 11/00
					108/139
D345,473	S *	3/1994	Grundmann	.....	D15/140
D351,026	S *	9/1994	Madera	.....	D24/183
D355,660	S *	2/1995	Holmes	.....	D14/299
D358,436	S *	5/1995	Piaget	.....	D21/669
D362,479	S *	9/1995	Destasio, Jr.	.....	D21/688
D363,067	S *	10/1995	Holmes	.....	D14/356
D363,325	S *	10/1995	Wilkinson	.....	D21/797
5,562,572	A *	10/1996	Carmein	.....	A61H 3/00
					482/4
D380,508	S *	7/1997	Chang	.....	D21/688
5,846,134	A *	12/1998	Latypov	.....	A63B 19/04
					463/46
5,879,276	A *	3/1999	Miller	.....	A63B 22/14
					482/131
D422,325	S *	4/2000	Broudy	.....	D21/689
6,152,854	A *	11/2000	Carmein	.....	A63B 22/025
					482/4
6,176,817	B1 *	1/2001	Carey	.....	A63B 22/18
					482/146
D437,619	S *	2/2001	Nishimura	.....	D21/333
D444,573	S *	7/2001	Owens	.....	D25/62
D479,860	S *	9/2003	Lim	.....	D14/217
6,692,419	B2 *	2/2004	Chen	.....	A63B 22/18
					482/146
D517,437	S *	3/2006	Barnes	.....	D10/91
D519,569	S *	4/2006	Kiyono	.....	D21/333
D538,358	S *	3/2007	Glier	.....	D21/662
D563,813	S *	3/2008	Tomita	.....	D10/92
D591,804	S *	5/2009	Tsuchida	.....	D21/662
D595,171	S *	6/2009	Robinson	.....	D10/91
D614,056	S *	4/2010	Ulrich	.....	D10/92
D615,436	S *	5/2010	Einfalt	.....	D10/92
D640,335	S *	6/2011	Aboody	.....	D21/662
8,016,732	B2 *	9/2011	Susnjara	.....	A63B 21/0004
					482/142
D651,258	S *	12/2011	Rivard	.....	D21/333
D660,928	S *	5/2012	Guarrasi	.....	D21/686
D662,949	S *	7/2012	Otero	.....	D14/203.1
8,512,142	B2 *	8/2013	Meldeau	.....	A63B 23/0458
					463/36
D694,349	S *	11/2013	Chen	.....	D21/686
D699,137	S *	2/2014	Wurts	.....	D10/91
D713,466	S *	9/2014	Otero	.....	D21/324
D738,444	S *	9/2015	Hilson	.....	D21/662

### OTHER PUBLICATIONS

virtuix-omni-treadmill-controller.jpg. gajitz.com. [online] 1 page  
 Uploaded Mar. 4, 2013 [retrieved on Feb. 11, 2016]. <http://gajitz.com/virtual-reality-gets-realer-motion-based-treadmill-control/>.\*  
 Omni treadmill concept. mtbs3d.com [online] 4 pages Posted May 29, 2013 [retrieved on Feb. 11, 2016] <http://www.mtbs3d.com/phpbb/viewtopic.php?f=138&t=17696>.\*  
 Kat Walk Mini-Kat VR. [online] 1 pg. uploaded Mar. 11, 2018 [Retrieved on Sep. 10, 2019] <https://katvr.com/wp-content/uploads/2018/03/11.jpg>.\*

\* cited by examiner



FIG. 1



FIG. 2

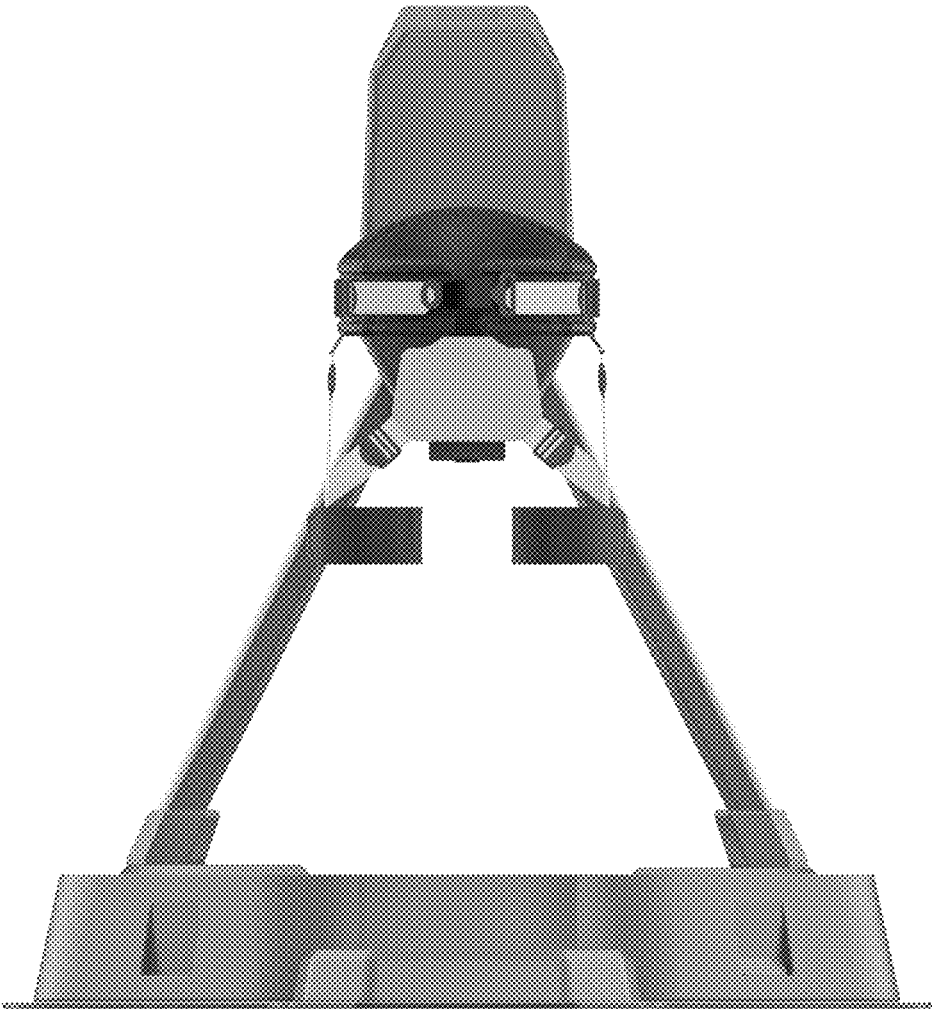

FIG. 3

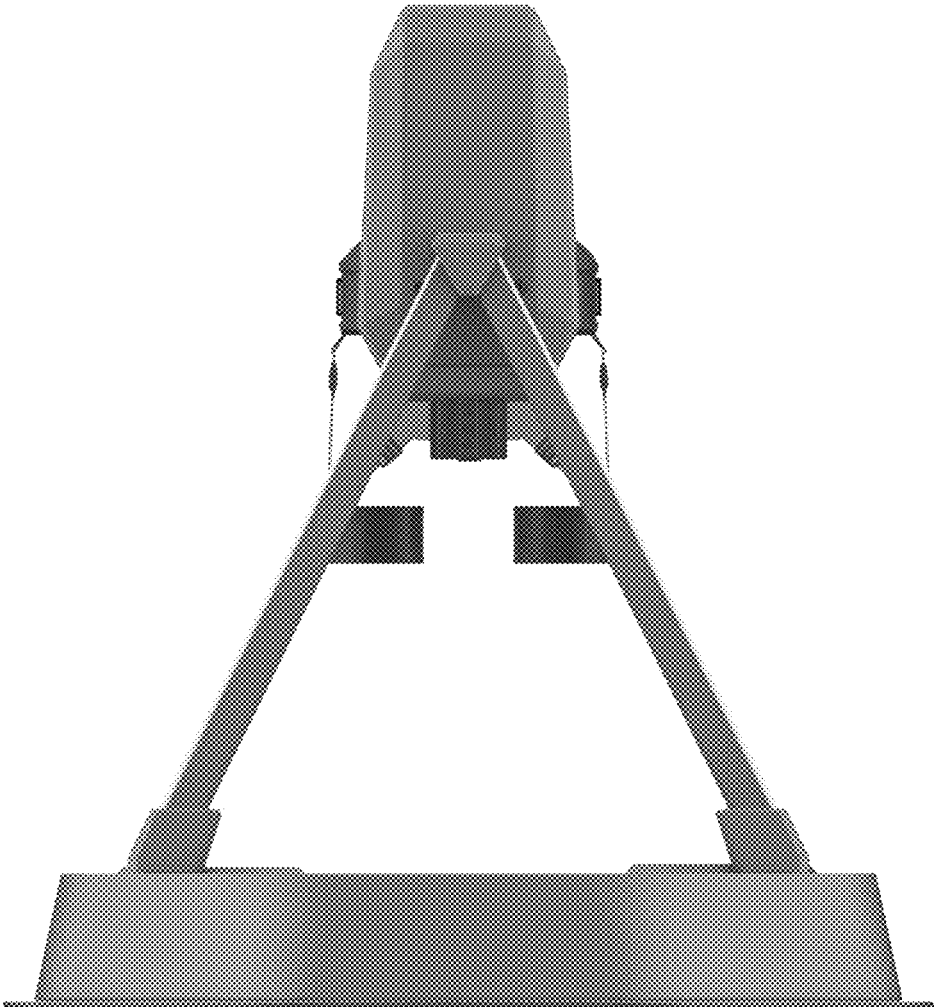

FIG. 4

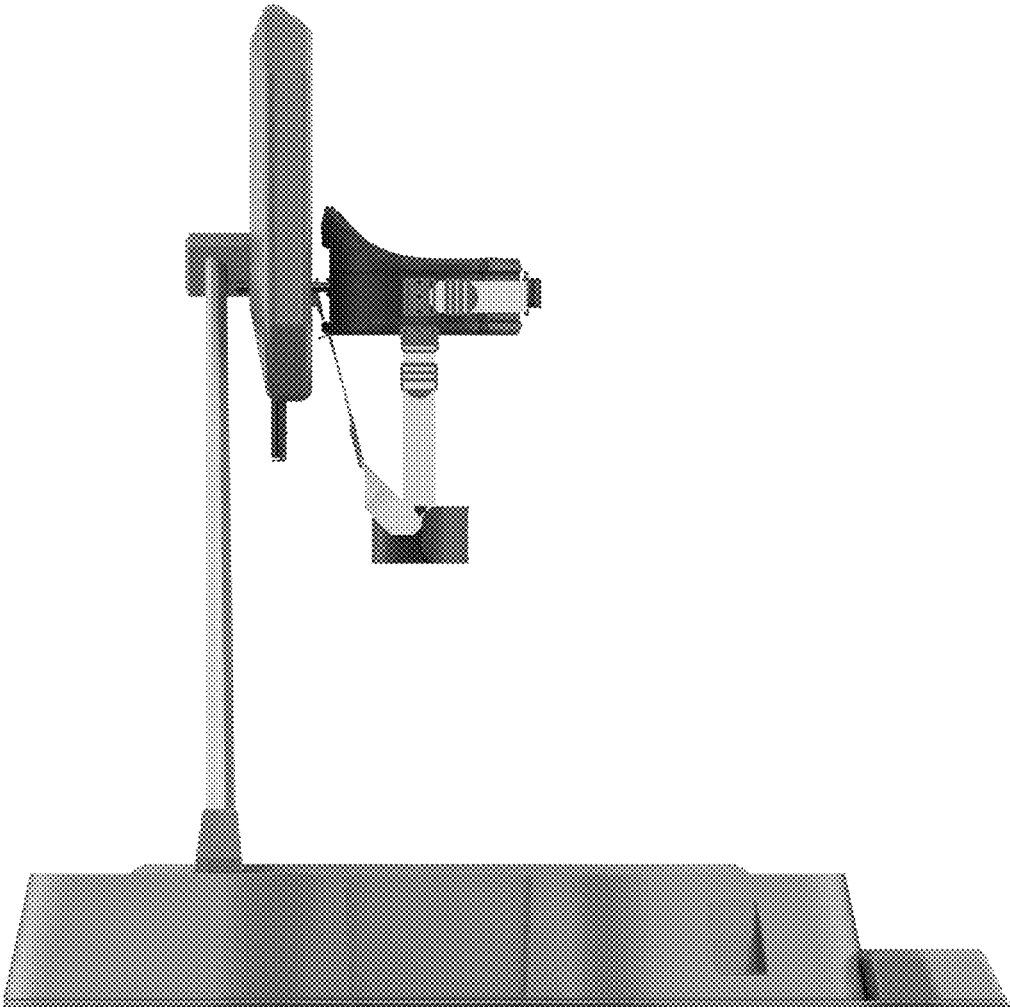

FIG. 5

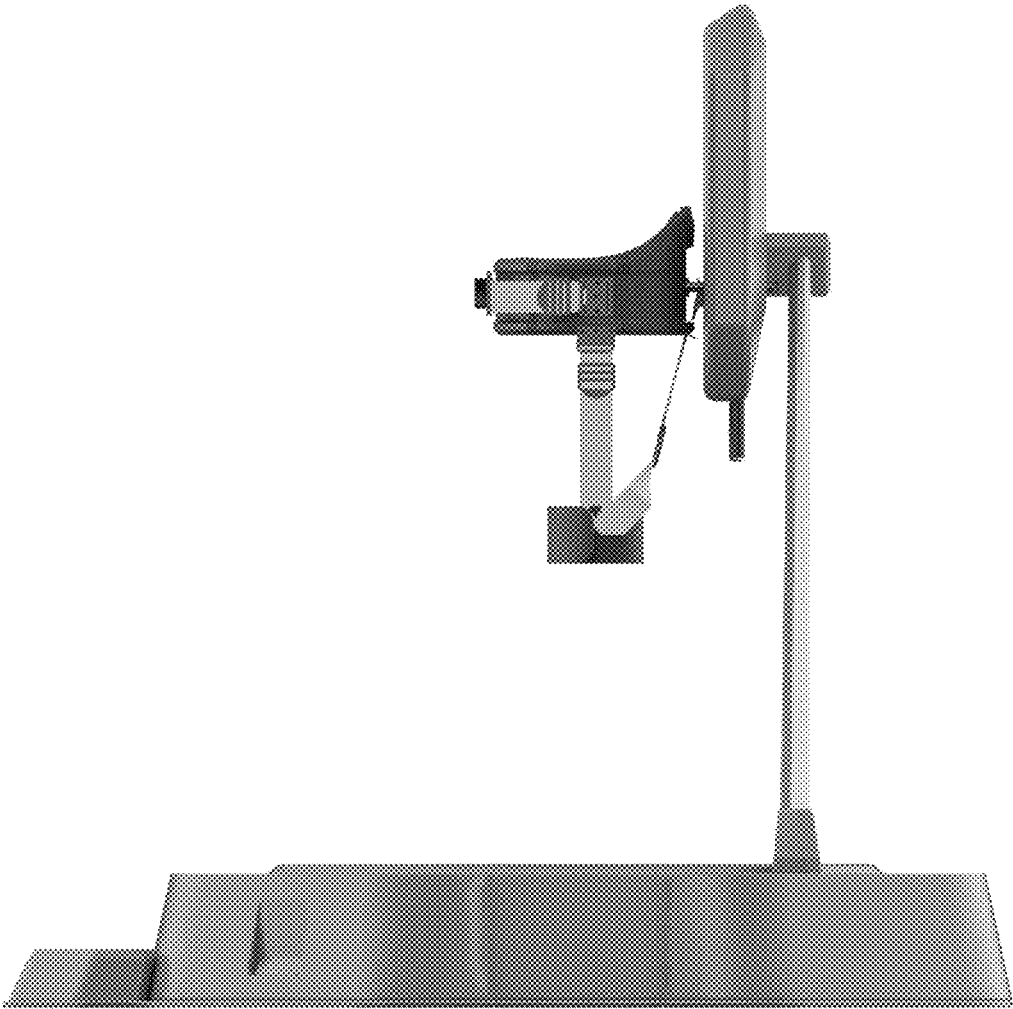

FIG. 6



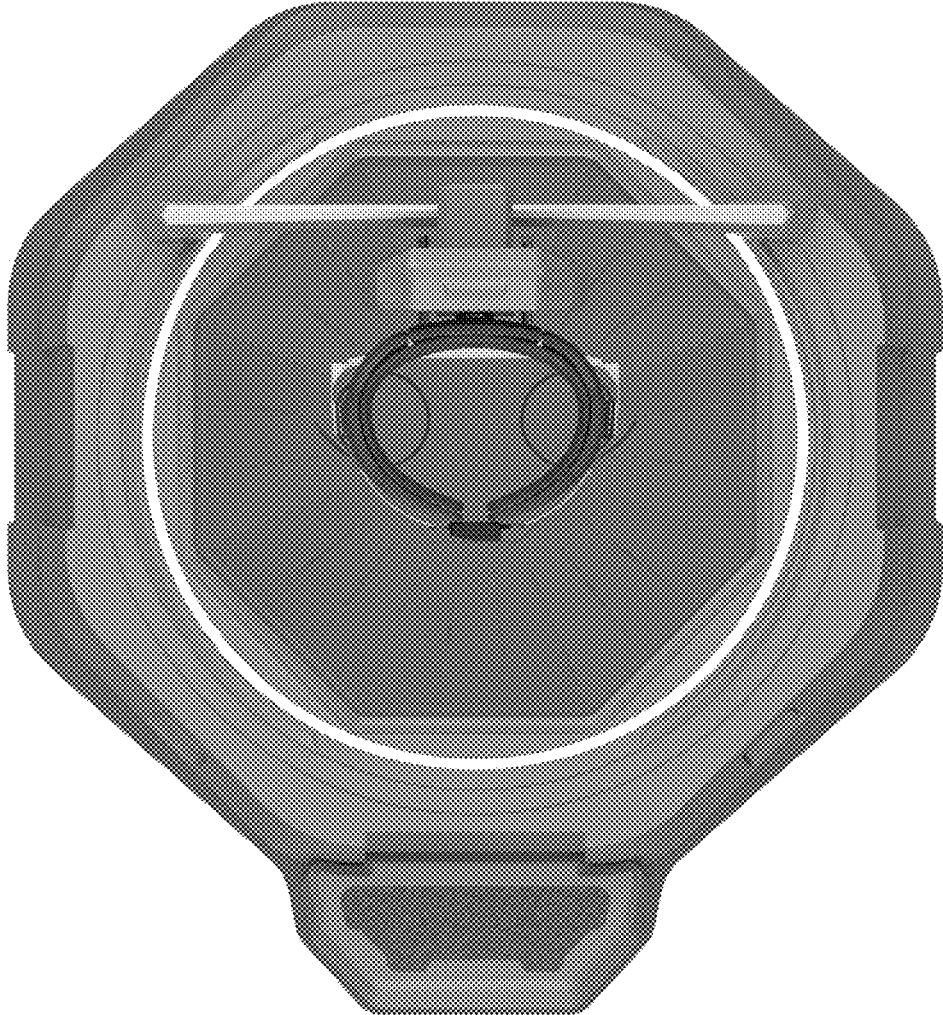

FIG. 7

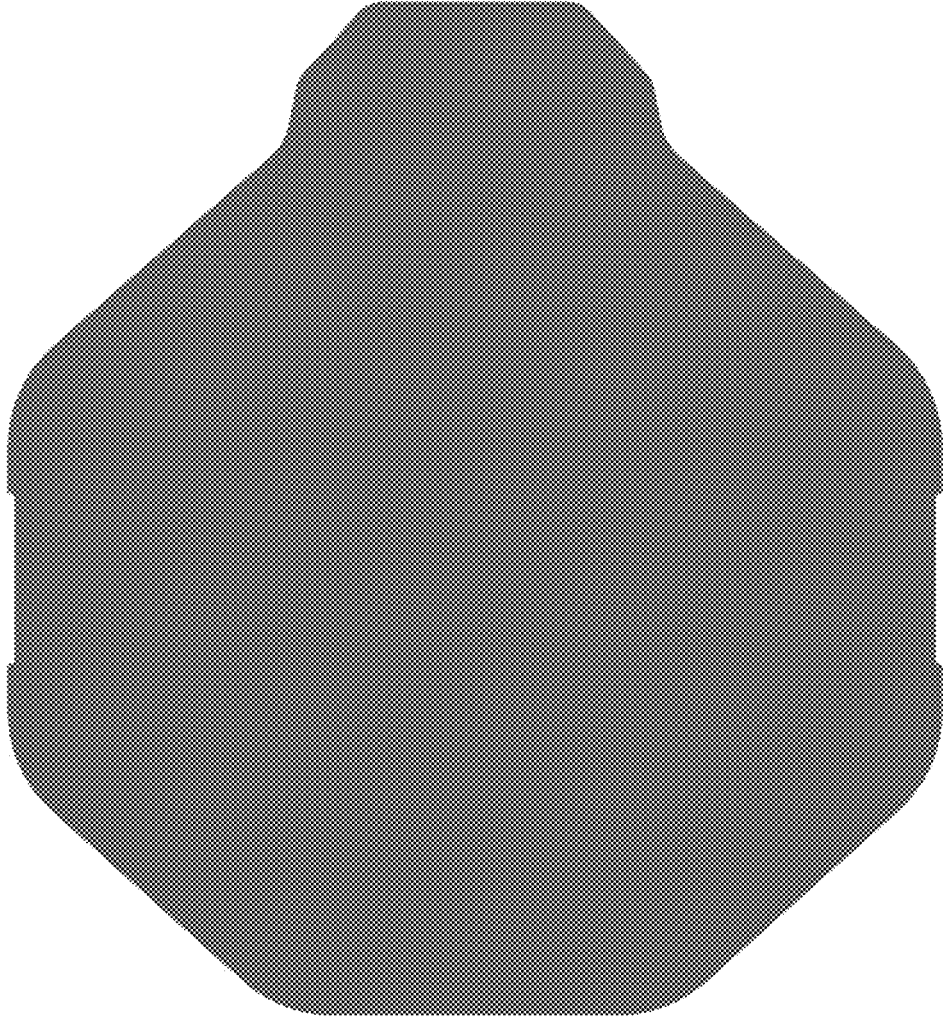

FIG. 8