



US00D968199S

(12) **United States Design Patent** (10) **Patent No.:** **US D968,199 S**
Keith et al. (45) **Date of Patent:** **** Nov. 1, 2022**

(54) **TIE STANDOFF**

FOREIGN PATENT DOCUMENTS

(71) Applicant: **HK MARKETING LC**, American Fork, UT (US)

CA 2392892 1/2003
CN 203891249 10/2014

(Continued)

(72) Inventors: **David O. Keith**, American Fork, UT (US); **Kevin M. Christensen**, Cedar Valley, UT (US); **Jordan O. Keith**, Saratoga Springs, UT (US); **Christopher C. Rhoades**, Eagle Mountain, UT (US)

OTHER PUBLICATIONS

Hercules 2.375-in x2.5-in Rebar Chair in the Rebar Chairs, Date Visited: Jun. 13, 2022, Lowes, Date Available: Jun. 13, 2022, <https://www.lowes.com/pd/Hercules-2-Inch-Steel-Mesh-Chair-100-Pack/5005412621> (Year: 2022).*

(Continued)

(73) Assignee: **HK Marketing LC**, American Fork, UT (US)

(**) Term: **15 Years**

Primary Examiner — Karen S Acker

Assistant Examiner — Elizabeth S Ko

(21) Appl. No.: **29/688,652**

(74) *Attorney, Agent, or Firm* — Workman Nydegger

(22) Filed: **Apr. 23, 2019**

(51) **LOC (13) Cl.** **08-11**

(57) **CLAIM**

(52) **U.S. Cl.**

The ornamental design for a tie standoff, as shown and described.

USPC **D8/363**

(58) **Field of Classification Search**

USPC ... D8/349, 350, 354–356, 46, 346, 363–364, D8/366, 400–402, 404, 499
CPC H01R 13/447; H01R 25/006; H01R 13/4534; H01R 27/02; H02G 3/14; H02G 3/185; H02G 3/081; H02G 3/12; Y10T 16/86; Y10T 29/4979; Y10T 70/5553; Y10T 70/5867; Y10T 24/1498; Y10T 403/55; Y10T 403/553; Y10T 403/75; Y10T 70/577; Y10T 70/7915; E04C 5/18; E04C 5/20; E04C 5/168; E04C 2/384; E04C

(Continued)

DESCRIPTION

FIG. 1 is a top perspective view of a tie standoff, shown in use with a tie.

FIG. 2 is a top perspective view of the tie standoff of FIG. 1, shown alone.

FIG. 3 is a bottom perspective view of the tie standoff of FIG. 2.

FIG. 4 is a top view of the tie standoff of FIG. 2.

FIG. 5 is a front view of the tie standoff of FIG. 2.

FIG. 6 is a rear view of the tie standoff of FIG. 2.

FIG. 7 is a bottom view of the tie standoff of FIG. 2.

FIG. 8 is a first side view of the tie standoff of FIG. 2; and

FIG. 9 is an opposite side view of the tie standoff of FIG. 2.

The tie shown in broken lines in FIGS. 1 and 10 is shown for environment and forms no part of the claimed design.

(56) **References Cited**

U.S. PATENT DOCUMENTS

581,776 A 5/1897 Seagrave
D35,565 S 1/1902 Godfrey

(Continued)

1 Claim, 4 Drawing Sheets

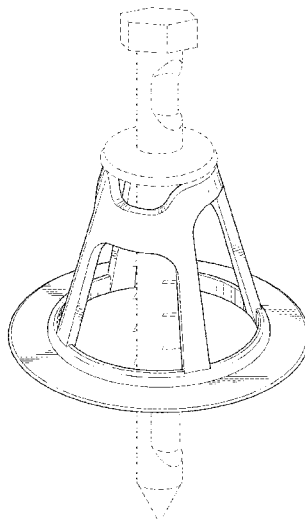

US D968,199 S

(58) **Field of Classification Search**
 CPC 5/03; E04C 5/201; E04C 5/203; E04C
 2/044; E04C 2/288; E04C 2002/047;
 E04C 2003/026; E04C 5/02; E04C 5/16;
 E04C 5/163; B62D 17/00; B60R 11/02;
 B60R 2011/0005; B60R 2011/0071;
 B60R 11/00; B60R 11/04; B60R
 2011/004; B60R 9/04; B60R 9/045; B60R
 9/06

See application file for complete search history.

(56) **References Cited**

U.S. PATENT DOCUMENTS

764,266 A 7/1904 Amrath
 773,926 A 11/1904 Clayton
 1,511,711 A 10/1924 Atwell
 1,736,704 A 11/1929 Gilbert
 1,876,683 A 9/1932 Johnson et al.
 2,236,082 A 6/1939 Wright
 2,302,878 A 11/1942 Muhl et al.
 2,645,929 A 12/1948 Jones
 2,819,863 A 1/1958 Vines
 D189,259 S 11/1960 Hughes
 D214,086 S 5/1969 Powell
 3,520,399 A 7/1970 Steffensen et al.
 3,822,958 A 7/1974 Lewis
 4,018,023 A 4/1977 Anderson
 4,162,134 A 7/1979 Kitagawa
 4,329,826 A 5/1982 Flogaus
 4,393,635 A 7/1983 Long
 4,545,163 A 10/1985 Asselin
 D284,267 S 6/1986 Lindell
 4,606,686 A 8/1986 Weaver
 D286,180 S 10/1986 Korthoff
 4,627,198 A 12/1986 Francies, III
 4,723,766 A 2/1988 Beeding
 4,754,758 A 7/1988 Li
 D298,916 S 12/1988 Beatty
 4,829,733 A 5/1989 Long
 4,846,655 A 7/1989 Gulley
 4,994,073 A 2/1991 Green
 5,011,354 A 4/1991 Browniee
 5,052,097 A 10/1991 Becker
 5,064,048 A 11/1991 Becker
 5,094,282 A 3/1992 Suzuki et al.
 5,141,212 A 8/1992 Beeding
 5,147,160 A 9/1992 Reed et al.
 D334,133 S * 3/1993 Hartzheim D8/354
 5,223,675 A 6/1993 Taft
 5,265,986 A 11/1993 Prokopp
 5,390,459 A 2/1995 Mensen
 D357,855 S 5/1995 Keith et al.
 5,415,507 A 5/1995 Janusz et al.
 5,429,460 A 7/1995 Campian
 5,433,558 A 7/1995 Gray
 D361,710 S 8/1995 Boeshart
 5,509,636 A 4/1996 Cotugno
 5,519,973 A 5/1996 Keith et al.
 5,570,983 A 11/1996 Hollander
 5,588,263 A 12/1996 Kelly et al.
 D378,049 S 2/1997 Boeshart
 5,606,832 A 3/1997 Keith et al.
 5,623,804 A 4/1997 Kelly et al.
 D383,373 S 9/1997 Boeshart
 5,671,574 A 9/1997 Long
 5,673,525 A 10/1997 Keith et al.
 D388,312 S * 12/1997 Sorkin D8/354
 5,692,356 A 12/1997 Baxter
 5,743,685 A 4/1998 Piggott
 D394,200 S * 5/1998 Hartzheim D8/354
 5,809,723 A 9/1998 Keith et al.
 5,830,399 A 11/1998 Keith et al.
 5,890,337 A 4/1999 Boeshart
 5,996,297 A 12/1999 Keith et al.
 6,079,176 A 6/2000 Westra

6,112,491 A 9/2000 Keith et al.
 6,116,836 A 9/2000 Long
 6,138,981 A 10/2000 Keith et al.
 D436,018 S 1/2001 Boeshart
 D436,674 S 1/2001 Lancelot, III
 D437,063 S 1/2001 Lancelot, III
 D438,649 S 3/2001 Lancelot, III
 D438,991 S 3/2001 Lancelot, III
 6,308,484 B1 10/2001 Severino
 6,314,697 B1 11/2001 Moore
 6,460,824 B1 10/2002 Lancelot, III
 6,511,252 B1 1/2003 Andros
 6,647,674 B1 11/2003 Lancelot, III
 D484,032 S 12/2003 Del Re
 6,668,502 B2 12/2003 Beliveau
 6,702,213 B2 * 3/2004 Kotzur B65D 5/5028
 242/157 R
 6,729,079 B2 5/2004 Francies, III
 D491,443 S * 6/2004 Lowery D8/380
 6,755,385 B2 6/2004 Lancelot et al.
 6,761,007 B2 7/2004 Lancelot et al.
 D500,243 S * 12/2004 Turek D8/354
 D500,668 S * 1/2005 Kelly D8/354
 6,854,229 B2 2/2005 Keith et al.
 6,892,722 B1 5/2005 Francies et al.
 6,895,720 B2 5/2005 Keith
 7,032,357 B2 4/2006 Cooper
 7,210,211 B2 5/2007 Harrison
 7,222,460 B2 5/2007 Francies et al.
 7,266,931 B2 9/2007 Long
 D578,379 S * 10/2008 Sorkin D8/354
 D578,870 S * 10/2008 Sorkin D8/354
 D581,776 S 12/2008 Yin-Feng
 7,461,492 B1 12/2008 Francies et al.
 D595,117 S * 6/2009 Sorkin D6/349
 D614,942 S 5/2010 Gaudron
 8,109,706 B2 2/2012 Richards
 8,333,536 B2 12/2012 Shih
 8,365,501 B2 2/2013 Long
 8,667,746 B1 3/2014 Francies, III
 8,677,697 B2 3/2014 Eklund et al.
 8,695,287 B1 4/2014 Francies, III
 8,696,284 B2 4/2014 Aicher
 8,745,943 B2 6/2014 Ciuperca
 8,800,220 B1 8/2014 Francies, III
 8,863,469 B2 10/2014 Curtis et al.
 D719,817 S * 12/2014 Perry D8/380
 8,898,964 B1 12/2014 Francies, III
 8,910,445 B2 12/2014 Hohmann
 D728,044 S 4/2015 Boatwright
 D736,067 S * 8/2015 Manning D8/354
 9,097,026 B2 * 8/2015 Hoffman E04F 21/20
 D738,195 S * 9/2015 Perry D8/380
 9,151,065 B1 10/2015 Francies, III
 9,169,635 B2 10/2015 Andrews
 D744,646 S 12/2015 Nering et al.
 9,279,259 B1 * 3/2016 Russo E04F 21/0092
 9,303,404 B2 4/2016 Naito et al.
 9,347,232 B1 5/2016 Francies, III
 D764,266 S 8/2016 Keith
 9,493,946 B2 11/2016 Foderberg et al.
 D773,926 S 12/2016 Sweeney
 D775,935 S * 1/2017 Sarajian D8/354
 9,617,746 B1 4/2017 Francies, III
 9,637,925 B2 5/2017 Francies, III
 9,638,353 B2 5/2017 Francies, III
 D791,579 S * 7/2017 Perry D8/354
 9,803,354 B1 10/2017 Francies, III
 D804,288 S 12/2017 Keith et al.
 1,000,928 A1 6/2018 Keith et al.
 10,000,928 B2 6/2018 Keith et al.
 10,132,080 B2 11/2018 Jensen
 D837,016 S * 1/2019 Psaila D8/71
 10,240,356 B2 3/2019 Mackay Sim
 10,267,037 B2 4/2019 Stewart
 D856,105 S * 8/2019 Dahill D8/71
 D856,106 S * 8/2019 Dahill D8/71
 D856,107 S * 8/2019 Dahill D8/71
 D856,121 S 8/2019 Keith et al.

(56)

References Cited

U.S. PATENT DOCUMENTS

D856,122 S 8/2019 Keith et al.
D856,772 S * 8/2019 Dahill D8/71
D857,473 S * 8/2019 Dahill D8/71
10,378,204 B2 8/2019 Gosain
D858,241 S * 9/2019 Dahill D8/71
D867,844 S * 11/2019 Dahill D8/71
10,577,813 B2 * 3/2020 Dahill E04F 21/22
D880,267 S * 4/2020 Dahill D8/71
D887,258 S 6/2020 Keith et al.
D889,940 S * 7/2020 Gilner D8/354
D927,966 S * 8/2021 Werlinger D8/354
D932,285 S * 10/2021 Gilner D8/354
D938,806 S * 12/2021 Moore D8/358
D938,807 S * 12/2021 Moore D8/358
D948,992 S * 4/2022 Werlinger D8/354
D951,743 S * 5/2022 Quesada Barbero D8/71
11,332,936 B1 * 5/2022 Staton E04C 5/20
2002/0026761 A1 3/2002 Moore
2002/0092253 A1 7/2002 Beliveau
2002/0096619 A1 7/2002 Lancelot, III
2003/0019169 A1 1/2003 Francies, III
2003/0029106 A1 2/2003 Cooper et al.
2003/0140590 A1 7/2003 Lancelot, III
2003/0208968 A1 11/2003 Lancelot, III
2003/0208969 A1 11/2003 Lancelot, III
2003/0208987 A1 11/2003 Lancelot, III
2004/0010985 A1 1/2004 Francies, III
2004/0055247 A1 3/2004 Keith
2004/0118067 A1 6/2004 Keith
2004/0136803 A1 7/2004 Gresch
2004/0179916 A1 9/2004 Susnjara et al.
2004/0237438 A1 12/2004 Keith et al.
2005/0016095 A1 1/2005 Long
2005/0028467 A1 2/2005 Bentley
2006/0032166 A1 2/2006 Devalapura
2006/0059847 A1 3/2006 Rice
2006/0096197 A1 5/2006 Tollefson
2007/0094974 A1 5/2007 Velickovic
2007/0113505 A1 5/2007 Beliveau
2007/0206997 A1 9/2007 Onsrud
2007/0231068 A1 10/2007 Francies et al.
2008/0028709 A1 2/2008 Pontarolo
2009/0013631 A1 1/2009 Devalapura
2009/0185880 A1 7/2009 Gong et al.
2009/0249725 A1 10/2009 McDonagh
2010/0005618 A1 1/2010 Minemura et al.
2011/0023303 A1 2/2011 Pervan et al.
2011/0094176 A1 4/2011 Bronner
2012/0063862 A1 3/2012 Epplin et al.
2012/0227335 A1 9/2012 Eklund et al.
2012/0266560 A1 10/2012 Panasik et al.
2013/0074433 A1 3/2013 Ciuperca
2013/0153628 A1 6/2013 Euteneuer
2013/0180192 A1 7/2013 Crosby
2013/0218177 A1 8/2013 Miksze et al.
2013/0263544 A1 10/2013 Pfeiffer
2013/0326980 A1 12/2013 Hilliard
2014/0020321 A1 1/2014 Eklund et al.
2014/0259990 A1 9/2014 Pfeiffer
2014/0260034 A1 9/2014 Ciuperca
2014/0260055 A1 9/2014 Pfeiffer
2015/0184383 A1 7/2015 Foderberg et al.
2015/0218806 A1 8/2015 Cossette
2016/0010330 A1 4/2016 Naito
2016/0123012 A1 5/2016 Francies, III
2016/0123501 A1 5/2016 Francies, III
2016/0215511 A1 7/2016 Salekarr
2017/0058520 A1 3/2017 Keith
2017/0204895 A1 7/2017 Rodenhouse
2017/0254072 A1 9/2017 Howorth et al.
2018/0079041 A1 3/2018 Schmauder
2018/0135318 A1 5/2018 Crosby

2018/0187436 A1 7/2018 Mackay Sim
2018/0238053 A1 11/2018 Jensen
2019/0091818 A1 3/2019 Winney
2019/0234072 A1 8/2019 Keith et al.

FOREIGN PATENT DOCUMENTS

DE 0846160 C 8/1952
DE 2027191 A1 12/1971
DE 19950715 A1 4/2000
DE 102014008232 A1 12/2015
DE 102014224604 A1 6/2016
EP 0129521 A2 12/1984
EP 2881343 A1 6/2015
JP 58-082612 A 5/1983
JP 2004225265 8/2004
JP 2006-263925 A 10/2006
RU 131396 8/2013
WO 2004/014589 A1 2/2004
WO 2013/175831 A1 11/2013
WO 2015/141898 A1 9/2015

OTHER PUBLICATIONS

Rebar Chair for Concrete Support, Date Visited: Jun. 13, 2022, Made in China, Date Available: Jun. 13, 2022, <https://m.made-in-china.com/product/Rebar-Chair-for-Concrete-Support-767364565.html> (Year: 2022).*

U.S. Appl. No. 29/656,554, filed May 7, 2019, Notice of Allowance.
U.S. Appl. No. 29/635,189, filed Jan. 29, 2018, Keith et al.
U.S. Appl. No. 29/656,554, filed Jul. 13, 2018, Keith et al.
U.S. Appl. No. 16/267,718, filed Feb. 5, 2019, Keith et al.
U.S. Appl. No. 16/058,837, filed Aug. 8, 2018, Keith et al.
BA Screw Threads Data Chart Accessed Jul. 24, 2016.
Photograph of competing tie, based on information and belief, photographed Jan. 30, 2019.
Questions and Answers about System SC for Structurally Composite Concrete Sandwich Walls. Boone: Thermomass System SC, 2012. Print.
Thermomass. "Insulated Cast-in-Place Construction Using Thermomass System CIP." Online video clip. YouTube. YouTube, Mar. 20, 2012. Web. Accessed Jan. 22, 2016. <<https://www.youtube.com/watch?v=VoHzDS9Yuwc>>.
Thermomass. Thermomass System SC, n.d. Web. Accessed Jan. 22, 2016. <<http://www.thermomass.com/>>.
U.S. Appl. No. 14/841,260, filed Jan. 15, 2016, Office Action.
U.S. Appl. No. 29/531,564, filed Apr. 18, 2016, Notice of Allowance.
U.S. Appl. No. 14/841,260, filed Jul. 29, 2016, Final Office Action.
U.S. Appl. No. 14/841,260, filed Jun. 6, 2017, Office Action.
U.S. Appl. No. 29/562,534, filed Oct. 16, 2017, Notice of Allowance.
U.S. Appl. No. 14/841,260, filed Dec. 15, 2017, Office Action.
U.S. Appl. No. 14/841,260, filed Apr. 13, 2018, Notice of Allowance.
U.S. Appl. No. 29/635,189, filed Jan. 11, 2019, Office Action.
Description DE102014008232A1 (translation) obtained at <https://worldwide.espacenet.com/> (last visited Sep. 25, 2020).
Notice of Allowance received for U.S. Appl. No. 16/267,718, dated Sep. 10, 2020.
U.S. Appl. filed Jun. 26, 2015, Keith et al., U.S. Appl. No. 29/531,564.
U.S. Appl. No. 14/841,260, dated Jun. 6, 2017, Office Action.
U.S. Appl. No. 29/635,189, filed May 1, 2019, Notice of Allowance.
U.S. Appl. filed Aug. 31, 2015, Keith et al., U.S. Appl. No. 14/841,260.
Non-Final Office Action received for U.S. Appl. No. 16/058,837, dated Jul. 12, 2021, 21 pages.

* cited by examiner

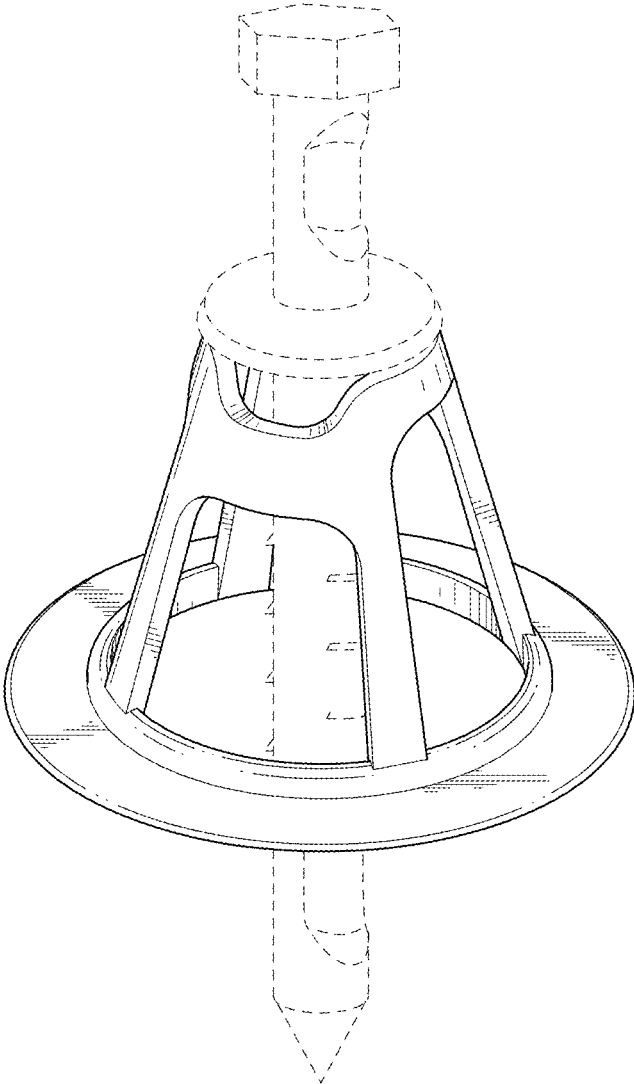

FIG. 1

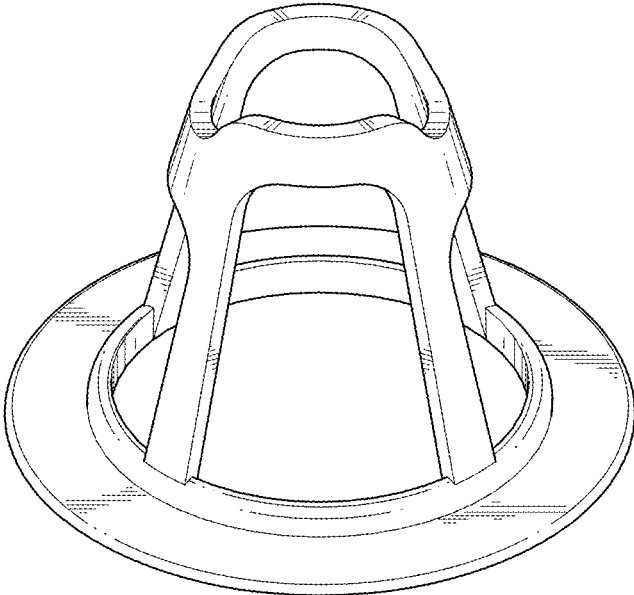

FIG. 2

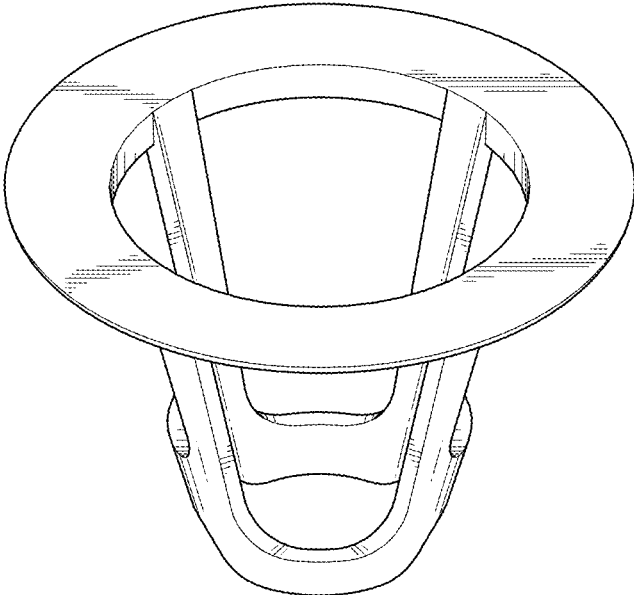

FIG. 3

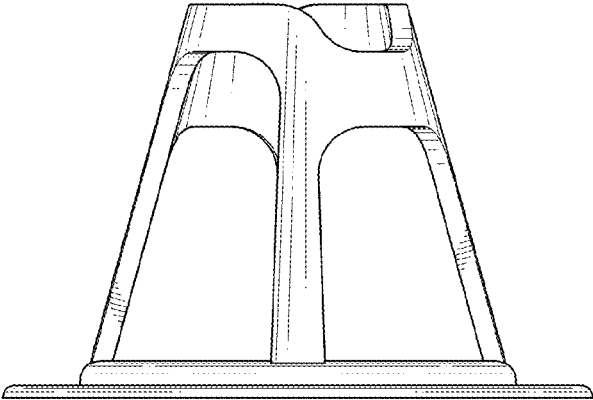

FIG. 5

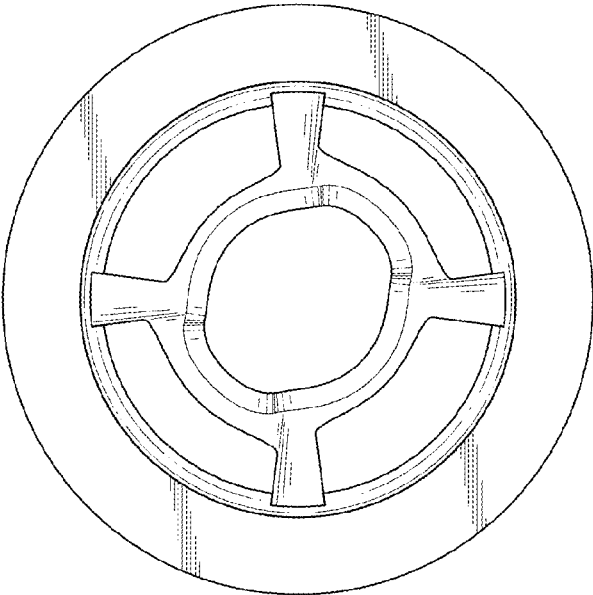

FIG. 4

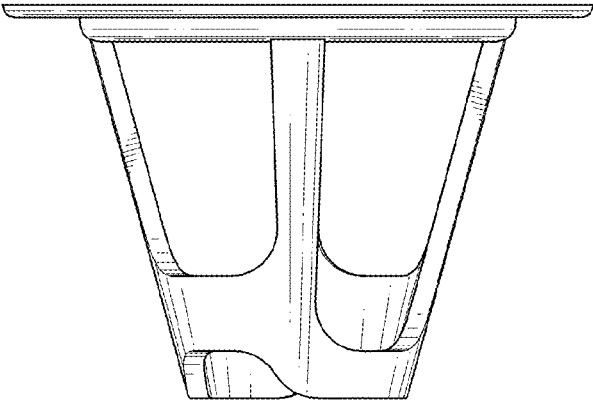

FIG. 6

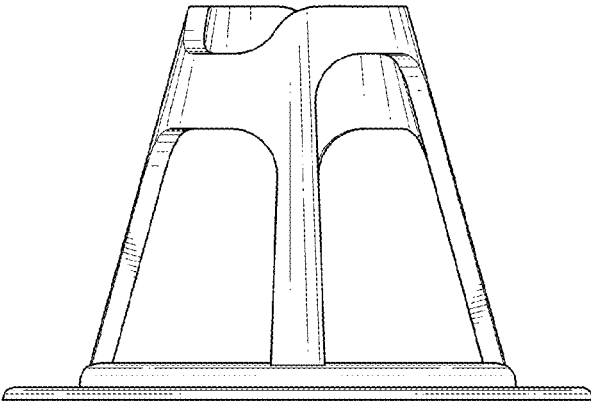

FIG. 8

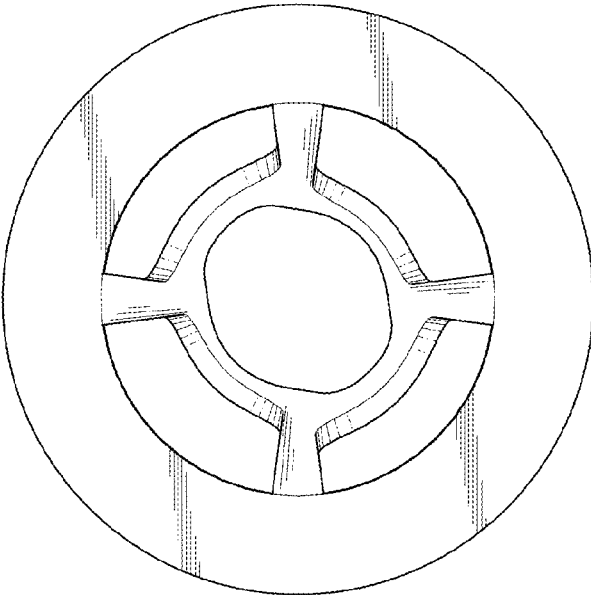

FIG. 7

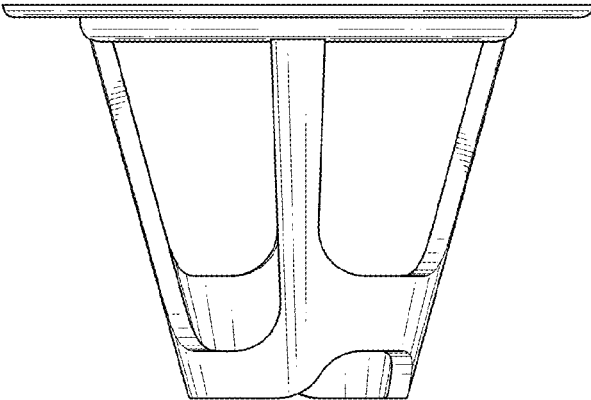

FIG. 9