



(86) Date de dépôt PCT/PCT Filing Date: 2013/05/16
 (87) Date publication PCT/PCT Publication Date: 2013/11/21
 (45) Date de délivrance/Issue Date: 2022/05/17
 (85) Entrée phase nationale/National Entry: 2014/11/17
 (86) N° demande PCT/PCT Application No.: US 2013/041278
 (87) N° publication PCT/PCT Publication No.: 2013/173541
 (30) Priorités/Priorities: 2012/05/18 (US61/688,630);
 2013/02/14 (US61/764,776)

(51) Cl.Int./Int.Cl. *G01J 3/36* (2006.01),
G01J 3/02 (2006.01)
 (72) Inventeurs/Inventors:
 KESTER, ROBERT T., US;
 HAGEN, NATHAN A., US
 (73) Propriétaire/Owner:
 REBELLION PHOTONICS, INC., US
 (74) Agent: MACRAE & CO.

(54) Titre : SYSTEME D'IMAGERIE SPECTRALE INFRAROUGE A OUVERTURE DIVISEE POUR DETECTION CHIMIQUE

(54) Title: DIVIDED-APERTURE INFRA-RED SPECTRAL IMAGING SYSTEM FOR CHEMICAL DETECTION

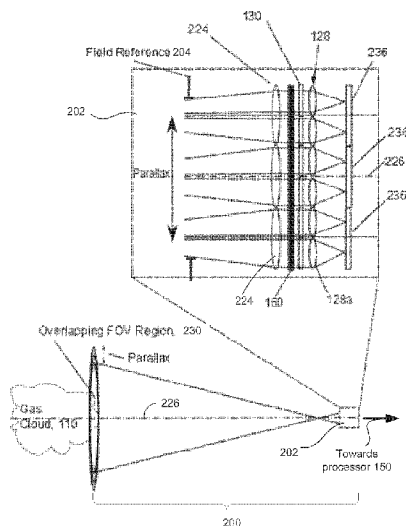

(57) **Abrégé/Abstract:**

A divided-aperture infrared spectral imaging (DAISI) system that is structured to provide identification of target chemical content in a single imaging shot based on spectrally-multiplexed operation. The system is devoid of spectral scanning acquisition of infrared (IR) spectral signatures of target content with an IR detector and does not require cooling. It comprises - an optical system including an optical focal plane array (FPA) unit that is devoid of a cooling means, and having components defining at least two optical channels thereof, said two optical channels being spatially and spectrally different from one another; - first and second temperature-controlled shutters; - a data-processing unit; - an optical aperture; - at least two spectrally-multiplexed optical filters, each filter positioned to transmit a portion of the IR radiation transmitted through a respectively corresponding channel from the at least two spatially and spectrally different optical channels, each optical filter including one of a longpass optical filter and a shortpass optical filter; and - at least two reimaging lenses, each reimaging lens disposed to transmit IR radiation, that has traversed a corresponding optical filter towards the optical FPA unit, wherein said optical FPA unit is positioned to receive IR radiation from the object through the at least two reimaging lenses to form respectively-corresponding two or more sets of imaging data representing the object.

(12) INTERNATIONAL APPLICATION PUBLISHED UNDER THE PATENT COOPERATION TREATY (PCT)

(19) World Intellectual Property

Organization

International Bureau

(43) International Publication Date

21 November 2013 (21.11.2013)



(10) International Publication Number

WO 2013/173541 A1

- (51) International Patent Classification:
G01J 3/36 (2006.01) G01J 3/02 (2006.01)
- (21) International Application Number:
PCT/US2013/041278
- (22) International Filing Date:
16 May 2013 (16.05.2013)
- (25) Filing Language:
English
- (26) Publication Language:
English
- (30) Priority Data:
61/688,630 18 May 2012 (18.05.2012) US
61/764,776 14 February 2013 (14.02.2013) US
- (71) Applicant (for all designated States except US): **REBEL-LION PHOTONICS, INC.** [US/US]; 7547 South Freeway, Houston, TX 77021 (US).
- (72) Inventors; and
(71) Applicants (for US only): **KESTER, Robert, T.** [US/US]; 7547 South Freeway, Houston, TX 77021 (US).
HAGAN, Nathan, A. [US/US]; 7547 South Freeway, Houston, TX 77021 (US).
- (74) Agent: **SIDORIN, Yakov**; Quarles & Brady LLP, One South Church Avenue, Suite 1700, Tuscon, AZ 85701-1621 (US).
- (81) Designated States (unless otherwise indicated, for every kind of national protection available): AE, AG, AL, AM, AO, AT, AU, AZ, BA, BB, BG, BH, BN, BR, BW, BY, BZ, CA, CH, CL, CN, CO, CR, CU, CZ, DE, DK, DM, DO, DZ, EC, EE, EG, ES, FI, GB, GD, GE, GH, GM, GT, HN, HR, HU, ID, IL, IN, IS, JP, KE, KG, KM, KN, KP, KR, KZ, LA, LC, LK, LR, LS, LT, LU, LY, MA, MD, ME, MG, MK, MN, MW, MX, MY, MZ, NA, NG, NI, NO, NZ, OM, PA, PE, PG, PH, PL, PT, QA, RO, RS, RU, RW, SC, SD, SE, SG, SK, SL, SM, ST, SV, SY, TH, TJ, TM, TN, TR, TT, TZ, UA, UG, US, UZ, VC, VN, ZA, ZM, ZW.
- (84) Designated States (unless otherwise indicated, for every kind of regional protection available): ARIPO (BW, GH, GM, KE, LR, LS, MW, MZ, NA, RW, SD, SL, SZ, TZ, UG, ZM, ZW), Eurasian (AM, AZ, BY, KG, KZ, RU, TJ, TM), European (AL, AT, BE, BG, CH, CY, CZ, DE, DK, EE, ES, FI, FR, GB, GR, HR, HU, IE, IS, IT, LT, LU, LV, MC, MK, MT, NL, NO, PL, PT, RO, RS, SE, SI, SK, SM, TR), OAPI (BF, BJ, CF, CG, CI, CM, GA, GN, GQ, GW, ML, MR, NE, SN, TD, TG).
- Published:
— with international search report (Art. 21(3))

(54) Title: DIVIDED-APERTURE INFRA-RED SPECTRAL IMAGING SYSTEM FOR CHEMICAL DETECTION

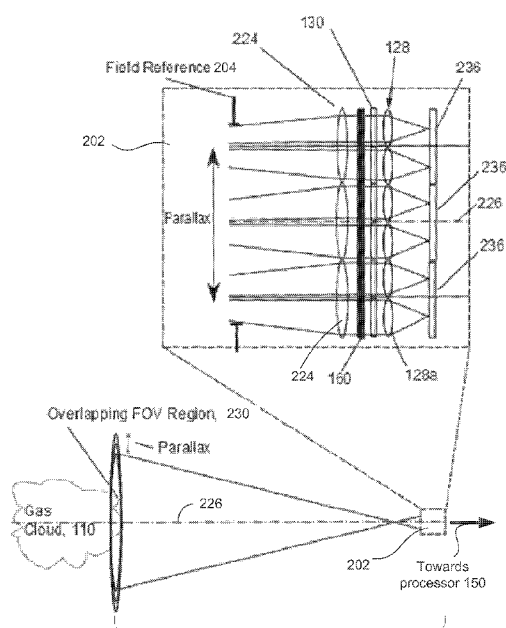

FIG. 2

(57) Abstract: A divided-aperture infrared spectral imaging (DAISI) system that is structured to provide identification of target chemical content in a single imaging shot based on spectrally-multiplexed operation. The system is devoid of spectral scanning acquisition of infrared (IR) spectral signatures of target content with an IR detector and does not require cooling. It comprises - an optical system including an optical focal plane array (FPA) unit that is devoid of a cooling means, and having components defining at least two optical channels thereof, said two optical channels being spatially and spectrally different from one another; - first and second temperature-controlled shutters; - a data-processing unit; - an optical aperture; - at least two spectrally-multiplexed optical filters, each filter positioned to transmit a portion of the IR radiation transmitted through a respectively corresponding optical channel from the at least two spatially and spectrally different optical channels, each optical filter including one of a longpass optical filter and a shortpass optical filter; and - at least two reimaging lenses, each reimaging lens disposed to transmit IR radiation, that has traversed a corresponding optical filter towards the optical FPA unit, wherein said optical FPA unit is positioned to receive IR radiation from the object through the at least two reimaging lenses to form respectively-corresponding two or more sets of imaging data representing the object.

DIVIDED-APERTURE INFRA-RED SPECTRAL IMAGING SYSTEM FOR CHEMICAL DETECTION

CROSS-REFERENCE TO RELATED APPLICATIONS

[0001] The present application claims benefit of and priority from the U.S. Provisional Applications numbers 61/688,630 filed on May 18, 2012 and titled "Divided Aperture Infrared Spectral Imager (DAISI) for Chemical Detection"; and 61/764,776 filed on February 14, 2013 and titled "Divided Aperture Infrared Spectral Imager for Chemical Detection".

TECHNICAL FIELD

[0002] The present invention generally relates to a system and method for gas cloud detection and, in particular, to a system and method of detection of spectral signatures of chemical compositions in a mid- and long-wave infrared spectral region with a use of systemic compensation for parallax-induced and motion-induced imaging artifacts.

BACKGROUND

[0003] Most of the existing IR spectral imaging systems require focal plane detector arrays (FPAs) that have to be highly sensitive and cooled in order to compensate, during the optical detection, for the reduction of the photon flux caused by spectrum-scanning operation. There remains a need, therefore, in a system enabling an optical data acquisition mode that does not require the cooling of the used detector(s), which detectors can be less sensitive to photons in the IR but yet well fit for continuous monitoring applications. There also remains a need in an IR imaging system the operation of which is substantially not susceptible to motion artifacts (which is a common problem with spectrally-scanning systems causing errors in either the spectral data, spatial data, or both).

SUMMARY

[0004] Embodiments of the present invention provide an infrared (IR) imaging system for determining a concentration of a target species in an object. The imaging system includes (i) an optical system, having an optical focal plane array (FPA) unit that is devoid of a cooling means, which optical system is configured to receive IR radiation from the object along at least two optical channels defined by components of the optical system, said at least two optical channels being spatially and spectrally different from one another; (ii) first and second temperature-

controlled shutters removably positioned to block IR radiation incident onto the optical system from the object; and (iii) a processor configured to acquire multispectral optical data representing said target species from the received IR radiation in a single occurrence of data acquisition. The optical system may include an optical aperture (a boundary of which is defined to circumscribe, encompass said at least two spatially distinct optical channels) and at least two spectrally-multiplexed optical filters. Each of these optical filters is positioned to transmit a portion of the IR radiation received in a respectively corresponding optical channel from the at least two spatially and spectrally different optical channels and includes at least one of a longpass optical filter and a shortpass optical filter (with or without a combination with another filter such as a notch filter, for example). The optical system may further include at least two reimaging lenses, each reimaging lens disposed to transmit IR radiation (in one embodiment - between about 1 micron and about 20 microns), that has been transmitted through a corresponding optical filter towards the optical FPA unit. In one embodiment, the optical FPA unit is positioned to receive IR radiation from the object through the at least two reimaging lenses to form respectively-corresponding two or more sets of imaging data representing the object and the processor is configured to acquire said optical data from the two or more sets of imaging data.

[0005] Embodiments of the present invention additionally provide a method for operating an infrared (IR) imaging system. The method includes receiving IR radiation from an object along at least two optical channels defined by components of an optical system of the IR imaging system, which at least two optical channels are spatially and spectrally different from one another. The method further includes transmitting the received IR radiation towards an optical focal plane array (FPA) unit that is not being cooled in the course of normal operation; and removably positioning at least one of at least two temperature-controlled shutters in front of the optical system to block IR radiation incident onto the optical system from the object.

BRIEF DESCRIPTION OF THE DRAWINGS

[0006] The invention will be more fully understood by referring to the following Detailed Description in conjunction with the Drawings, of which:

FIG. 1 shows an embodiment of the system of the invention utilizing a common front objective lens that has a pupil divided spectrally and re-imaged onto an infrared FPA.

FIG.2 shows an embodiment with a divided front objective lens and an array of infrared sensing FPAs.

FIG. 3A represents an embodiment employing an array of front objective lenses operably matched with the re-imaging lens array.

FIG. 3B illustrates a two-dimensional array of optical components corresponding to the embodiment of Fig. 3A.

FIG. 4 is a diagram of the embodiment employing an array of field references and an array of respectively corresponding relay lenses.

FIG. 5A is a diagram of a 4-by-3 pupil array of circular optical filters (and IR blocking material among them) used to spectrally divide an optical wavefront imaged with an embodiment of the invention.

FIG. 5B is a diagram of a 4-by-3 pupil array of rectangular optical filters (and IR blocking material among them) used to spectrally divide an optical wavefront imaged with an embodiment of the invention.

FIG. 6A depicts theoretical plots of transmission characteristics of a combination of band-pass filters used with an embodiment of the invention.

FIG. 6B depicts theoretical plots of transmission characteristics of spectrally multiplexed notch-pass filter combination used in an embodiment of the invention.

FIG. 6C shows theoretical plots of transmission characteristics of spectrally multiplexed long-pass filter combination used in an embodiment of the invention.

FIG. 6D shows theoretical plots of transmission characteristics of spectrally multiplexed short-pass filter combination used in an embodiment of the invention.

FIG. 7 is a set of video-frames illustrating operability of an embodiment of the invention used for gas detection.

FIGS. 8A, 8B are plots illustrating results of dynamic calibration of an embodiment of the invention.

DETAILED DESCRIPTION

[0007] Embodiments of the present invention illustrate a divided-aperture infrared spectral imaging (DAISI) system that is structured and adapted to provide identification of target chemical contents of the imaged scene based on spectrally-multiplexed operation and single-shot (also referred to as snapshot), that is devoid of spectral and spatial scanning acquisition of infrared (IR) spectral signatures of the target chemical contents with an IR detector (such as, for example, infrared focal plane array or FPA) to form a spectral cube of imaging data. In contradistinction to commonly used IR imaging systems, the DAISI system does not require cooling.

[0008] Implementations of the present invention provide several operational advantages over existing IR spectral imaging systems, most if not all of which require FPAs that have to be highly sensitive and cooled in order to compensate, during the optical detection, for the reduction

of the photon flux caused by spectrum-scanning operation. The highly sensitive and cooled FPA systems are expensive and require a great deal of maintenance. As an embodiment of the invention is configured to operate in single-shot acquisition mode, the instrument receives photons from every point of the object substantially simultaneously, during the single reading. In comparison with a system of related art, this feature enables an embodiment to collect a substantially greater amount of optical power from the imaged scene (for example, an order of magnitude more photons) at any given moment in time. Consequently, an embodiment is enabled to operate using uncooled detector(s) (for example, FPA such as an array of microbolometers) that are less sensitive to photons in the IR but are well fit for continuous monitoring applications since they are capable of operating in extreme weather conditions, require less power, can operate both day and night, and are less expensive. On the other hand, embodiments of the invention are advantageous in that their operation is substantially immune to motion artifacts (which is a common problem with spectrally-scanning systems causing errors in either the spectral data, spatial data, or both). Moreover, present embodiments are structured to acquire spectrally-multiplexed datacubes during a single-shot acquisition which, when combined with the detector-noise limited performance of the FPA's, result in increase of level of the detected signal by a factor of 2 to 10 times, as compared with the systems of related art.

[0009] References throughout this specification to "one embodiment," "an embodiment," "a related embodiment," or similar language mean that a particular feature, structure, or characteristic described in connection with the referred to "embodiment" is included in at least one embodiment of the present invention. Thus, appearances of the phrases "in one embodiment," "in an embodiment," and similar language throughout this specification may, but do not necessarily, all refer to the same embodiment. It is to be understood that no portion of disclosure, taken on its own and in possible connection with a figure, is intended to provide a complete description of all features of the invention.

[0010] In the drawings like numbers are used to represent the same or similar elements wherever possible. The depicted structural elements are generally not to scale, and certain components are enlarged relative to the other components for purposes of emphasis and understanding. It is to be understood that no single drawing is intended to support a complete description of all features of the invention. In other words, a given drawing is generally descriptive of only some, and generally not all, features of the invention. A given drawing and an associated portion of the disclosure containing a description referencing such drawing do not, generally, contain all elements of a particular view or all features that can be presented in this view, for purposes of simplifying the given drawing and discussion, and to direct the discussion to particular elements that are featured in this drawing. A skilled artisan will recognize that the

invention may possibly be practiced without one or more of the specific features, elements, components, structures, details, or characteristics, or with the use of other methods, components, materials, and so forth. Therefore, although a particular detail of an embodiment of the invention may not be necessarily shown in each and every drawing describing such embodiment, the presence of this detail in the drawing may be implied unless the context of the description requires otherwise. In other instances, well known structures, details, materials, or operations may be not shown in a given drawing or described in detail to avoid obscuring aspects of an embodiment of the invention that are being discussed. Furthermore, the described single features, structures, or characteristics of the invention may be combined in any suitable manner in one or more further embodiments.

[00011] Moreover, if the schematic flow chart diagram is included, it is generally set forth as a logical flow-chart diagram. As such, the depicted order and labeled steps of the logical flow are indicative of one embodiment of the presented method. Other steps and methods may be conceived that are equivalent in function, logic, or effect to one or more steps, or portions thereof, of the illustrated method. Additionally, the format and symbols employed are provided to explain the logical steps of the method and are understood not to limit the scope of the method. Although various arrow types and line types may be employed in the flow-chart diagrams, they are understood not to limit the scope of the corresponding method. Indeed, some arrows or other connectors may be used to indicate only the logical flow of the method. For instance, an arrow may indicate a waiting or monitoring period of unspecified duration between enumerated steps of the depicted method. Without loss of generality, the order in which processing steps or particular methods occur may or may not strictly adhere to the order of the corresponding steps shown.

[00012] The invention as recited in claims appended to this disclosure is intended to be assessed in light of the disclosure as a whole, including features disclosed in prior art to which reference is made.

[00013] Fig. 1 provides a diagram schematically illustrating a spatial and spectral division of incoming light by an embodiment **100** of the system of the invention (also referred to as DAISI system) that is enabled to image an object **110** possessing IR spectral signature(s). An aperture of the system (associated with a front objective lens system **124**) is spatially and spectrally divided. The spatial and spectral division of the aperture into distinct aperture portions corresponding to separate channels **120** (in object space and/or image space) along which light propagates through the aperture is enabled with the use of an array **128** of re-imaging lenses **128a** and an array of spectral filters **130**, which respectively correspond to the distinct channels **120**. In one implementation, the distinct channels **120** may include optical channels that are separated in angular space. The array of spectral filters **130** may additionally include a filter-holding

aperture mask (containing, for example, IR light-blocking materials such as ceramic, metal, or plastic). Light from the object **110** (such as a cloud of gas, for example), the optical properties of which in the IR are described by a unique absorption, reflection and/or emission spectrum, is received by the aperture of the system through each of the channels **120** and is further imaged onto an optical detector component **136** (which may include at least one FPA). Each of the re-imaging lenses **128a** is spatially aligned with a respectively-corresponding region of the divided aperture and, therefore, with respectively-corresponding spatial channel **120** to form, on the FPA component **136** a single sub- image of the object **110**. Generally, two or more sub-images of the object can be characterized by close or substantially equal spectral signatures. The FPA component **136** is further operably connected with a processor **150** (not shown) specifically programmed to aggregate the data acquired with the system **100** into a spectral datacube representing, in spatial (x, y) and spectral (λ) coordinates an overall spectral image of the object **110** within the spectral region defined by the combination of the filters **130**. Additionally, the processor **150** may be optionally and specifically programmed to determine the unique absorption characteristic of the object **110** and, alternatively or in addition, map the overall image datacube into a cube of data representing spatial distribution of concentrations c of targeted chemical components within the field of view associated with the object **110**.

[00014] In order to facilitate the operational performance of the embodiment **100**, an optional moveable temperature-controlled reference target **160** (including, for example, a shutter system containing two reference shutters maintained at different temperatures) is removably and, in one implementation, periodically inserted into an optical path of light traversing the system **100** from the object **110** to the FPA component **130** along at least one of the channels **120** to block such optical path and to provide a reference IR spectrum required to recalibrate the operation of the system **100** in real time. The configuration of the moveable reference(s) **160** is further discussed below.

[00015] In the embodiment **100**, the front objective lens system **124** is shown to include a single front objective lens positioned to establish a common field-of-view (FOV) for the reimaging lenses **128a** and to define an aperture stop for the whole system (which, in this specific case, substantially spatially coincides with limiting apertures corresponding to different optical channels **120**). As a result, the positions for spectral encoding of the different optical channels **120** coincide with the position of the aperture stop of the whole system, which is defined as a surface between the lens system **124** and the array **128** of the reimaging lenses **128a**. Generally, however, the field apertures corresponding to different optical channels may be located in different planes. In one implementation the field apertures corresponding to different optical channels are located in different planes, which planes are optical conjugates of one another (as

defined by the whole optical system). Similarly, while all of the spectral filters **130** of the embodiment **100** are shown to lie in one plane, generally spectral filters corresponding to different optical filters can be associated with different planes. In one implementation, different spectral filters **130** are situated in different planes are that are optically conjugate to one another.

[00016] The front objective lens element of the system can generally include an array of front objective lenses configured across the IR wavefront emitted by the object being imaged with the DAISI system such as to divide such wavefront spatially in a non-overlapping fashion. To this end, Fig. 2 illustrates a related embodiment **200**, in which a front optical portion contributing to the spatial division of the aperture of the system is defined by a multiplicity of objective lenses **224** configured as a two-dimensional (2D) array of lenses. Fig. 2 presents a general view of the system **200** and, in figure insert, a portion **202** of it in greater detail, including a field reference (aperture stop) **204**. The configuration **200** has an operational advantage over embodiment **100** of Fig. 1 in that the overall size and/or weight and/or cost of manufacture of the embodiment **200** is critically reduced while the associated parallax (the change in the FOVs of individual lenses **224** of the lens-array disposed across and substantially perpendicularly to a general optical axis **226** of the embodiment **200**; marked as **228**) is substantially small. As the distance between the portion **202** and the object **110** increases, the overlapping region **230** between the FOVs of the individual lenses **224** increases while the amount of parallax **228** remains approximately the same, thereby reducing its effect on the system **200**. When the ratio of the parallax-to-object-distance is substantially equal to the pixel-size -to-system-focal-length ratio then the parallax effect may be considered to be negligible and, for practical purposes, no longer distinguishable. While the lenses **224** are shown to be disposed substantially in the same plane, optionally the array of front objective lenses such as lenses **224** can be defined in more than one plane. For example, some of the individual lenses **224** can be displaced with respect to some other individual lenses **224** along the axis **226** (not shown). It is noted that when multiple detectors **236** are employed with the embodiment **200**, the embodiment is preferably complemented with field reference **204** to operate properly, as discussed below.

[00017] In one implementation, the front objective lens system such as the array of lenses **224** is configured as an array of lenses integrated or molded in association with a monolithic substrate, thereby reducing the costs and complexity otherwise accompanying the optical adjustment of individual lenses within the system. An individual lens **224** can optionally include a lens with varying magnification. As one example, a pair of thin and large diameter Alvarez plates can be used to define at least a portion of the front objective lens system.

[00018] In further reference to Fig. 1, the FPA component configured to receive the optical data representing spectral signature(s) of the imaged object can be configured as a single FPA

136 adapted to acquire more than one sub-image (formed along more than one optical channel **120**) simultaneously. Alternatively, the detector component may include a set of optical FPAs at least one of which can be configured to acquired more than one spectrally distinct sub-image of the imaged object. (For example, as shown in the embodiment **200** of Fig. 2, an array of optical FPAs can include FPAs **236** the number of which may correspond to the number of the front objective lenses **224**). In one implementation of the system, an array of optical FPAs includes an array of microbolometers. The use of multiple microbolometers advantageously allows for an inexpensive way to increase the total number of detection elements (i.e. pixels) for recording of the datacube in one snapshot. An array of microbolometers more efficiently utilizes the detector pixels for each FPA as the number of unused pixels is minimized and/or eliminated between the sub-images that may exist when using a single microbolometer.

[00019] Fig. 3A illustrates schematically a related embodiment **300** of the imaging system of the invention, in which the number of the front objective lenses **324a** in the lens array **324**, the number of re-imaging lenses **128a** in the lens array **128**, and the number of FPAs **336** are the same. So configured, each combination of respectively corresponding front objective lens **324**, re-imaging lens **128a**, and FPA **336** defines an individual imaging channel associated with acquisition of the IR light transmitted from the object **110** through an individual optical filter component **130**. A field reference **338** of the system **300** is configured to have a uniform temperature across its surface and be characterized by a predetermined spectral curve of radiation emanating therefrom. The field reference **338** is used for dynamically adjusting the data output from each FPA **336** after acquisition of light from the object **110** to ensure that output of each of the FPAs **336** represents correct acquired data, with respect to the other FPAs **336** for analysis, as discussed below in more detail. In one implementation, when a 4 x 3 array **340** of optical components (lenses **324a**, **128a**; detector elements **336**), shown schematically in Fig. 3B, is used behind the temperature controlled reference target **160**, the field reference **338** is adapted to obscure and/or block a peripheral portion of the bundle of light propagating from the object **110** towards the detector(s) **336**. As a result, the field reference **338** obscures and/or blocks the border or peripheral portion(s) of the images of the object **110** formed on the FPA elements located along the perimeter **346** of the detector system. Generally, two detector elements will be producing substantially equal values of digital counts when they are used to observe the same portion of the scene in the same spectral region using the same optical train. If any of these input parameters (scene to be observed, spectral content of light from the scene, or optical elements delivering light from the scene to the two detector elements) differ, the counts associated with the detectors will differ as well. Accordingly, and as an example, in a case when the two FPAs **336** (such as

those denoted as #6 and #7 in Fig. 3B) remain substantially un-obscured by the field reference 338, the outputs from these FPAs can be -dynamically adjusted to the output from one of the FPAs located along border (such as, for example, the FPA element # 2) that processes spectrally similar light.

[00020] Fig. 4 illustrates schematically a portion of another embodiment 400 that contains an array 424 of front objective lenses 424a adapted to receive light from the object 110 that relay the received light to the array 128 of re-imaging lenses 128a through an array 438 of field references (field stops) 438a the spectral characteristics of which are known, and through an array 440 of the relay lenses. The field references 438a are disposed at corresponding intermediate image planes defined, with respect to the object 110, by respectively corresponding front objective lenses 424a. (When refractive characteristics of all of the front objective lenses 424a are substantially the same, all of the field references 438a are disposed in the same plane). A field reference 438a of the array 438 obscures (casts a shadow on) a peripheral region of a corresponding sub-image formed at the detector plane 444 through a respectively corresponding spatial imaging channel 450 of the system 400 prior to such sub-image being spectrally processed by the processor 150. The array 440 of relay lenses then transmits light along each of the imaging channels 450 through different spectral filters 454a of the filter array 454, past the two-point calibration apparatus that includes two temperature controlled shutters 460a, 460b, and then onto the detector module 456 (a microbolometer array or other IR FPA).

[00021] The embodiment 400 commissions several operational advantages. It is configured to provide a spectrally known object within every sub-image and for every snapshot acquisition which can be calibrated against. (Such spectral certainty is expedient when using an array of IR FPAs like microbolometers the detection characteristics of which can change from one imaging frame to the next due to, in part, changes in the scene being imaged as well as the thermal effects caused by neighboring FPAs.) In addition, the field reference array 438 of the embodiment 400 is preferably - but not necessarily - disposed within the Rayleigh range (\sim the depth of focus) associated with the front objective lenses 424, thereby removing unusable blurred pixels due to having the field reference outside of this range. Moreover, the embodiment 400 is more compact than, for example, the configuration 300 of Fig. 3A (which requires the employed field reference 338 to be separated from the lens array 324 by a distance greater than several (for example, five) focal lengths to minimize blur contributed by the field reference to an image formed at a detector plane.

[00022] In another related embodiment (not shown in Figs. 1, 2, 3A, and 4), the multi-optical FPA unit of the IR imaging system of the invention additionally includes an FPA

configured to operate in a visible portion of the spectrum. In reference to Fig. 1, for example, an image of the scene of interest formed by such visible-light FPA may be used as a background to form a composite image by overlapping (whether virtually, with the use of a processor and specifically-designed computer program product enabling such data processing, or actually, by a viewer) an IR image (that is created based on the image data acquired by the individual FPAs **130**) with the visible-light image. The so-formed composite image facilitates the identification of the precise spatial location of the target species the spectral signatures of which the system of the invention is enabled to detect and recognize.

[00023] *Optical Filters.* It is appreciated that the optical filters, used with an embodiment of the system, that define spectrally-distinct IR sub-images of the object can employ absorption filters, interference filters, and Fabry-Perot etalon based filters, to name just a few. When interference filters are used, the image acquisition through an individual imaging channel defined by an individual reimaging lens (such as a lens **128a** of Figs. 1, 2, 3, and 4) may be carried out in a single spectral bandwidth or multiple spectral bandwidths. Referring again to the embodiments **100, 200, 300, 400** of Figs. 1 through 4, and in further reference to Fig. 3B, examples of a 4-by-3 array of spectral filters **130** is shown in Figs. 5A, 5B, where individual filters 1 through 12 are juxtaposed with a supporting opto-mechanical element (not shown) to define a filter-array plane that is oriented, in operation, substantially perpendicularly to the general optical axis **226** of the embodiment.

[00024] The optical filtering configuration of one present embodiment advantageously differs from a common approach used to measure spectra with an array of FPAs, where a bandpass filter defining a specified spectral band (such as, for example, any of the filters *0a* through *4a* the transmission curves of which are shown in Fig. 6A) is placed in front of the optical FPA (generally, between the optical FPA and the object). In particular, and in further reference to Figs. 1, 2 3, and 4 when optical detector(s) **136, 236, 336, 456** of an embodiment include(s) microbolometers, the predominant contribution to noise associated with image acquisition is due detector noise. To compensate and/or reduce the noise, an embodiment of the invention utilizes spectrally-multiplexed filters. An example of spectral transmission characteristics of spectrally-multiplexed filters *0b* through *4b* for use with an embodiment of the invention is depicted in Fig. 6B. (Filters of Fig. 6B are so-called long-wavelength pass, LP filters. An LP filter generally attenuates shorter wavelengths and transmits (passes) longer wavelengths over the active range of the target IR portion of the spectrum. It is appreciated that, in a related embodiment, short-wavelength-pass filters, SP, may also be used. An SP filter generally attenuates longer wavelengths and transmits (passes) shorter wavelengths over the active range of the target IR portion of the spectrum.)

[00025] The related art appears to be silent with respect to an IR imaging system, adapted for detection of spectral signatures of chemical species that combines the use of the spectrally-multiplexed filters with a snap-shot image acquisition. The lack of such teaching can probably be explained by the fact that related imaging systems require the use of highly sensitive and, for that reason, expensive cooled FPAs with reduced noise characteristics. Accordingly, the systems of the related art are commonly employing bandpass filters instead, to take full advantage of spectral sensitivity of the used FPAs. Simply put, the use of spectrally multiplexed filters such as notched, LP, and SP filters would be counterproductive in a system of the related art, and would at least reduce an otherwise achievable SNR thereby degrading the performance of the related art system for the intended purpose. In contradistinction with the systems of the related art, however, and at least in part due to the snap-shot / non-scanning mode of operation, an embodiment of the imaging system of the invention is enabled to use less sensitive microbolometers without compromising the SNR. The use of microbolometers, as detector-noise-limited devices, in turn not only benefits from the use of spectrally multiplexed filters, but also does not require cooling of the imaging system during normal operation.

[00026] Referring again to Figs. 6A, 6B, each of the filters (*0b...4b*) transmits light in a substantially wider region of spectrum as compared to those of the filters (*0a...4a*). Accordingly, when the spectrally-multiplexed set of filters (*0b...0d*) is used with an embodiment of the invention, the overall amount of light received by the FPAs (for example, 236, 336) is larger than would be received when using the bandpass filters (*0a...4a*). This "added" transmission of light defined by the use of the spectrally-multiplexed LP (or SP) filters facilitates increase of the signal on the FPAs above the level of the detector noise. Additionally, by using, in an embodiment of the invention, filters the spectra of which are wider than those of conventionally used band-pass filters, the uncooled FPAs of the embodiment experience less heating due radiation incident thereon from the imaged scene and from radiation emanation form the FPA in question itself, due to a reduction in the back-reflected thermal emission(s) coming from the FPA and reflecting off of the filter from the non band-pass regions. As the transmission region of the multiplexed LP (or SP) filters is wider, such parasitic effects are reduced thereby improving the overall performance of the FPA unit.

[00027] In one implementation, the LP and SP filters can be combined, in a spectrally-multiplexed fashion as described, in order to maximize the spectral extent of the transmission region of the filter system of the embodiment.

[00028] The advantage of using spectrally multiplexed filters is appreciated based on the following derivation, in which a system of M filters is examined (although it is understood that in practice an embodiment of the invention can employ any number of filters). For illustration, the case of $M = 7$ is considered. Analysis presented below relates to one spatial location in each of sub-images formed by differing imaging channels defined by the system. As similar analysis can be performed for each point at a sub-image, the analysis can be appropriately extended as required.

[00029] The unknown amount of light within each of the M spectral channels (corresponding to these M filters) is denoted with $f_1, f_2, f_3, \dots, f_M$, and readings from corresponding detector elements receiving light transmitted by each filter is denoted as $g_1, g_2, g_3, \dots, g_M$, while measurement errors are represented by $n_1, n_2, n_3, \dots, n_M$. Then, the readings at the seven FPA pixels each of which is optically filtered by a corresponding bandpass filter of Fig. 6A can be represented by:

$$\begin{aligned} g_1 &= f_1 + n_1, \\ g_2 &= f_2 + n_2, \\ g_3 &= f_3 + n_3, \\ g_4 &= f_4 + n_4, \\ g_5 &= f_5 + n_5, \\ g_6 &= f_6 + n_6, \\ g_7 &= f_7 + n_7, \end{aligned}$$

[00030] These readings (pixel measurements) g_i are estimates of the spectral intensities f_i . The estimates g_i are not equal to the corresponding f_i values because of the measurement errors n_i . However, if the measurement noise distribution has zero mean, then the ensemble mean of each individual measurement can be considered to be equal to the true value, i.e. $\langle g_i \rangle = f_i$. Here, the angle brackets indicate the operation of calculating the ensemble mean of a stochastic variable. The variance of the measurement can, therefore, be represented as:

$$\langle (g_i - f_i)^2 \rangle = \langle n_i^2 \rangle = \sigma^2$$

[00031] In an alternative design utilizing spectrally-multiplexed filters and in comparison with the design utilizing bandpass filters, the amount of radiant energy transmitted by each of the spectrally-multiplexed LP or SP filters towards a given detector element can exceed that transmitted through a spectral band of a bandpass filter. IN this case, the intensities of light corresponding to the independent spectral bands can be reconstructed by computational means. (Such design is referred to as a "multiplex design").

[00032] One matrix of such "multiplexed filter" measurements includes a Hadamard matrix (requiring "negative" filters that may not be necessarily appropriate for the optical embodiments disclosed herein) An S-matrix approach (which is restricted to having a number of filters equal to an integer that is multiple of four minus one) or a row-doubled Hadamard matrix (requiring a number of filters to be equal to an integer multiple of eight) present alternative methodologies. Here, possible numbers of filters using an S-matrix setup are 3, 7, 11, etc and, if a row-doubled Hadamard matrix setup is used, then 8, 16, 24, etc. For example, the goal of the measurement may be to measure seven spectral band f_i intensities using seven measurements g_i as follows:

$$g_1 = f_1 + 0 + f_2 + 0 + f_3 + 0 + f_7 + n_1,$$

$$g_2 = 0 + f_2 + f_3 + 0 + 0 + f_6 + f_7 + n_2$$

$$g_3 = f_1 + f_2 + 0 + 0 + f_3 + 0 + f_7 + n_3$$

$$g_4 = 0 + 0 + 0 + f_4 + f_5 + f_7 + f_8 + n_4$$

$$g_5 = f_1 + 0 + f_2 + f_4 + 0 + f_5 + 0 + n_5$$

$$g_6 = 0 + f_2 + f_3 + f_4 + f_5 + 0 + 0 + n_6$$

$$g_7 = f_1 + f_2 + 0 + f_4 + 0 + 0 + f_7 + n_7$$

[00033] Optical transmission characteristics of the filters described above are depicted in Fig. 6B. Here, we no longer have a direct estimate of the f_i through a relationship similar to $\langle g_i \rangle = f_i$. Instead, if a "hat" notation is used to denote an estimate of a given value, then a linear combination of the measurements can be used such as, for example,

$$\hat{f}_1 = \frac{1}{4}(+g_1 - g_2 + g_3 - g_4 + g_5 - g_6 + g_7),$$

$$\hat{f}_2 = \frac{1}{4}(-g_1 + g_2 + g_3 - g_4 - g_5 + g_6 + g_7),$$

$$\hat{f}_3 = \frac{1}{4}(+g_1 + g_2 - g_3 - g_4 + g_5 + g_6 - g_7),$$

$$\hat{f}_4 = \frac{1}{4}(-g_1 - g_2 - g_3 + g_4 + g_5 + g_6 + g_7),$$

$$\hat{f}_5 = \frac{1}{4}(+g_1 - g_2 + g_3 + g_4 - g_5 + g_6 - g_7),$$

$$\hat{f}_8 = \frac{1}{4}(-g_1 + g_2 + g_3 + g_4 + g_5 - g_6 - g_7),$$

$$\hat{f}_7 = \frac{1}{4}(+g_1 + g_2 - g_3 + g_4 - g_5 - g_6 + g_7).$$

[00034] These \hat{f}_i are unbiased estimates when the n_i are zero mean stochastic variables, so that $\langle \hat{f}_i - f_i \rangle = 0$. The measurement variance corresponding to i th measurement is

$$\langle (\hat{f}_i - f_i)^2 \rangle = \frac{7}{16} \sigma^2$$

Therefore, by employing spectrally-multiplexed system the signal-to-noise ratio (SNR) of a measurement has been improved by a factor of $\sqrt{16/7} = 1.51$.

[00035] For N channels, the SNR improvement achieved with a spectrally-multiplexed system can be expressed as $(N + 1)/(2\sqrt{N})$. For example, in an embodiment employing 12 spectral channels is characterized by SNR improvement, over a non-spectrally-multiplexed system, by a factor of up to 1.88.

[00036] Two additional examples of related spectrally-multiplexed filter arrangements $0c$ through $4c$, $0d$ through $4d$ from the use of which an embodiment of the invention can benefit when such embodiment includes an uncooled FPA (such as a microbolometer) are shown in Figs. 6C and 6D. Fig. 6C illustrates a set of spectrally-multiplexed long-wavelength pass (LP) filters is used in the system. An LP filter generally attenuates shorter wavelengths and transmits (passes) longer wavelengths over the active range of the target IR portion of the spectrum. A single spectral channel having a transmission characteristic corresponding to the difference between the spectral transmission curved of at least two of these LP filters can be used to procure imaging data for the datacube with an embodiment of the invention.

[00037] As alluded to above, an embodiment may optionally, and in addition to temperature-controlled reference unit (for example temperature controlled shutters such as shutters **160**; **160a**, **160b**), employ a field reference component (**338** in Fig. 3A), or an array of field reference components (**438** in Fig. 4), to enable dynamic calibration for spectral acquisition of every datacube, a spectrally-neutral camera-to-camera combination to enable dynamic compensation of parallax artifacts, and a visible and/or IR camera for compensation of motion artifacts. The use of the temperature-controlled reference unit (for example, temperature-controlled shutter system **160**) and field-reference component(s) facilitates maintenance of proper calibration of each of the FPAs individually and the entire FPA unit as a whole.

[00038] In particular, and in further reference to Figs.1, 2, 3, and 4, the temperature-controlled unit generally employs a system having first and second temperature zones maintained at first and second different temperatures. For example, shutter system of each of the embodiments **100, 200, 300 and 400** can employ not one but at least two temperature-controlled shutters that are substantially parallel to one another and transverse to the general optical axis **226** of the embodiment(s) **100, 200, 300, 400**. Referring, for example, to Fig. 4, in which such multi-shutter structure is already indicated, the use of multiple shutters enables the user to create a known reference temperature difference perceived, by the FPAs **456** through the IR radiation emitted by the shutter(s) **160a, 160b** when these shutters are positioned to block the radiation from the object **110**. As a result, not only the offset values corresponding to each of the individual FPAs pixels can be adjusted but also the gain values of these FPAs. In an alternative embodiment, the system having first and second temperature zones may include a single or multi-portion piece (such as a plate, for example) mechanically-movable across the optical axis with the use of appropriate guides and having a first portion at a first temperature and a second portion at a second temperature.

[00039] Indeed, the process of calibration of an embodiment of the invention starts with estimating gain and offset (that vary from detector pixel to detector pixel) by performing measurements of radiation emanating, independently, from at least two temperature-controlled shutters of known and different radiances. Specifically, first the response of the detector unit **456** to radiation emanating from one shutter (for example, shutter **160a** that is blocking the FOV of the detectors **456** and the temperature T_1 of which is measured directly and independently with thermistors) is carried out. Following such initial measurement, the shutter **160a** is removed from the optical path of light traversing the embodiment and another shutter (for example, **160b**) is inserted in its place across the optical axis **226** to prevent the propagation of light through the system. The temperature of the second shutter **160b** is $T_2 \neq T_1$ is also independently measured with thermistors placed in contact with this shutter, and the detector response to radiation emanating from the shutter **160b** is also recorded. Denoting operational response of FPA pixels (expressed in digital numbers, or "counts") as g_i to a source of radiance L_i , the readings corresponding to the measurements of the two shutters can be expressed as:

$$\begin{aligned} g_1 &= \gamma L_1(T_1) + g_{offset} \\ g_2 &= \gamma L_2(T_2) + g_{offset} \end{aligned}$$

[00040] Here, g_{offset} is the pixel offset value (in units of counts), and γ is the pixel gain value (in units of counts per radiance unit). The solutions of these two equations with respect

to the two unknowns g_{offset} and γ can be obtained if the values of g_1 and g_2 and the radiance values L_1 and L_2 are available (either measured by a reference instrument or calculated from the known temperatures T_1 and T_2 together with the known spectral response of the optical system and FPA). For any subsequent measurement, one can then invert the equation(s) above in order to estimate the radiance value of the object from the detector measurement, and this can be done for each pixel in each FPA array within the system.

[00041] As already discussed, and in reference to Figs. 1 through 4 the field-reference apertures may be disposed in an object space or image space of the optical system, and dimensioned to block a particular portion of the IR radiation received from the object that, in absence of the field-reference aperture, would transmit through the optical system without traversing at least two spectrally-multiplexed optical filters. For example, the field-reference aperture the opening of which is substantially similar, in shape, to the boundary of the filter array (for example, and in reference to a filter array of Figs. 3B, 5B - rectangular), can be placed in front of the objective lens (**124**, **224**, **324**, **424**) at a distance that is at least several times (in one implementation - at least five times) larger than the focal length of the lens in order to minimize the image blur that would occur in absence of such field-reference. In the embodiment **400** of Fig. 4 the field-reference aperture can be placed within the depth of focus of an image conjugate plane formed by the front objective lens **424**. The field reference, generally, effectuates and/or enables dynamic compensation in the system by providing a spectrally known and temporally-stable object within every scene to reference and stabilize the output from the different FPAs in the array.

[00042] Because each FPA's offset value is generally adjusted from each frame to the next frame by the hardware, comparing the outputs of one FPA with another can have an error that is not compensated for by the calibration parameters g_{offset} and γ . In order to ensure that FPAs operate in radiometric agreement, it is necessary for a portion of each detector array to view a reference source (such as the field reference **338** in Fig. 3A, for example). Since the reference source spectrum is known a priori (such as a blackbody source at a known temperature), one can measure the response of each FPA to the reference source in order to estimate changes to the pixel offset value. An example calculation of the dynamic offset proceeds as follows.

[00043] Among the FPA elements in an array of FPAs in a given embodiment of the invention, we select one FPA to be the "reference FPA". We will attempt to make all of the FPAs agree with this one about the field reference temperature. The image measured in each FPA contains a set of pixels obscured by the field reference **338**. Using the previously

obtained calibration parameters g_{offset} and γ (the pixel offset and gain), we estimate the effective blackbody temperature T of the field reference as measured by each FPA i . That is,

$$T_i = \text{mean}\{(g + \Delta g_i + g_{offset}) / \gamma\} = \text{mean}\{(g - g_{offset}) / \gamma\} + \Delta T_i$$

[00044] Here, the mean value is procured over all pixels that are obscured by the field reference, and Δg_i is the difference in offset value of the current frame from Δg_{offset} obtained during the calibration step. For the reference FPA, Δg_i is simply set to zero. Then, using the temperature differences measured by each FPA, one obtains

$$T_i - T_{ref} = \text{mean}\{(g + \Delta g_i + g_{offset}) / \gamma\} + \Delta T_i - \text{mean}\{(g - g_{offset}) / \gamma\} = \Delta T_i$$

[00045] Once ΔT_i for each FPA is measured, its value can be subtracted from each image in order to force operational agreement between such FPA and the reference FPA. While the calibration procedure has been discussed above in reference to calibration of temperature, a procedurally similar methodology of calibration with respect to radiance value can be implemented.

[00046] Examples of Methodology of Measurements. Prior to optical data acquisition with an embodiment of the IR imaging system of the invention, it is preferred to calibrate all the FPAs of the system (such as FPAs 336 each of which forms an image of the object in light delivered in a corresponding optical channel defined by the combination of the corresponding front objective and re-imaging lenses 324, 128a, in reference to Fig. 3). The calibration is necessitated by a need to form individual images in equivalent units (so that, for example, the reading from each of the FPA pixels can be re-calculated in units of temperature or radiance units). Moreover, while it is often neglected in practice, each of the FPAs should be spatially co-registered with one another so that a given pixel of a particular FPA can be confidently optically re-mapped through the optical system of the embodiment to the same location at the object as the corresponding pixel at another FPA.

[00047] To achieve at least some of these goals, a so-called *spectral differencing* method may be employed, which employs forming a difference image from various combinations of the images registered by two or more different FPAs. If the optical filter 130 corresponding to a particular FPA 336 transmits light from the object including a cloud of gas, for example, with a certain spectrum that contains the gas absorption peak or a gas emission peak while another filter 130 corresponding to another FPA 336 does not transmit such spectrum, then

the difference between the images formed by the two FPAs at issue will highlight the presence of gas in the difference image.

[00048] A shortcoming of the spectral differencing method is that contributions of some auxiliary features associated with imaging (not just the target species such as gas itself) can also be highlighted in and contribute to the difference image. The so contributing effects include, to name just a few, parallax-induced imaging of edges of the object, influence of magnification differences between the two or more optical channels, and differences in rotational positioning and orientation between the FPAs. While magnification-related errors and FPA-rotation-caused errors can be compensated for by increasing the accuracy of the instrument construction as well as by post-processing of the acquired imaging, parallax is scene-induced and is not so easily correctable. In addition, while it is not widely recognized, the spectral differencing method is vulnerable to radiance calibration errors. Specifically, if one FPA registers radiance of light from a given feature of the object as that having a temperature of 40°C, for example, while the data from another FPA represents the temperature of the same object feature as being 39°C, then such feature of the object will be enhanced or highlighted in the difference image (formed at least in part based on the images provided by these two FPAs) due to such radiance-calibration error.

[00049] One solution to some of the problems introduced by the spectral differencing is to normalize the resulting image data by the data corresponding to a temporal reference image. This is referred to, for the purposes of this disclosure, as a *temporal differencing* algorithm or method. A temporal reference image may be formed, for example, by creating a difference image from the two or more images registered by the two or more FPAs at a single instance in time. It does not matter whether corollary of the use of the algorithm of the invention is that a prior knowledge of whether the object or scene contains a target species (such as gas of interest) does not affect the results because the algorithm highlights changes in the scene characteristics. Then, a spectral difference image can be calculated as discussed above based on a snap-shot image acquisition at any later time and subtracted from the temporal reference image to form a normalized difference image. The difference between the two highlights the target species (gas) within the normalized difference image, since this species was not present in the temporal reference frame. If necessary, more than two FPAs can be used both for registering the temporal reference image and a later-acquired difference image to obtain a better SNR figure of merit.

[00050] While the temporal differencing method can be used to reduce or eliminate some of the shortcomings of the spectral differencing, it can introduce unwanted problems of its own. For example, temporal differencing of imaging data is less sensitive to calibration and

parallax induced errors than the spectral differencing of imaging data. However, any change in the imaged scene which is not related to the target species of interest (such as particular gas, for example) is highlighted in a temporally-differenced image, and thus may be erroneously perceived as a location of the target species triggering, therefore, an error in detection of target species. For example, if the temperature of the scenic background against which the gas is being detected changes (due to natural cooling down as the day progresses, or increases due to a person or animal or another object passing through the FOV of the IR imaging system), then such temperature change produces a signal difference as compared to the measurement taken earlier in time. Accordingly, the cause of the scenic temperature change (the cooling object, the person walking, etc.) may appear as the detected target species (such as gas). It follows, therefore, that an attempt to compensate for operational differences among the individual FPAs of a multi-FPA IR imaging system with the use of methods that turn on spectral or temporal differencing cause additional problems leading to false detection of target species. Among these problems are scene-motion-induced detection errors and parallax-caused errors that are not readily correctable and/or compensatable as of to-date. Accordingly, there is an unfulfilled need to compensate for image data acquisition and processing errors caused by motion of elements within the scene being imaged. Embodiments of data processing algorithms of the present invention address and fulfill the need to compensate for the motion-induced and parallax-induced image detection errors.

[00051] In particular, to minimize parallax-induced differences between the images produced with two or more predetermined FPAs, another difference image is used that is formed from the images of at least two different FPAs to estimate parallax effects. For example, the spectral differencing of the image data is being performed with the use of the difference between the images collected by the outermost two cameras in the array (such as, for example, the FPAs corresponding to filters 2 and 3 of the array of filters of Fig. 5A), forming a difference image referred to as a "difference image 2-3". In this case, the alternative "difference image 1-4" is additionally formed from the image data acquired by, for example, the alternative FPAs corresponding to filters 1 and 4 of Fig. 5A. Assuming or ensuring that both of these two alternative FPAs have approximately the same spectral sensitivity to the target species, the alternative "difference image 1-4" will highlight pixels corresponding to parallax-induced features in the image. Accordingly, based on positive determination that the same pixels are highlighted in the spectral "difference image 2-3" used for target species detection, the conclusion is made that the image features corresponding to these pixels are likely to be induced by parallax and not the presence of target species in the imaged scene. It should be noted that compensation of parallax can also be performed using

images created by individual re-imaging lenses, 128a, when using a single FPA or multiple FPA's as discussed above.

[00052] Another capability of the embodiment of the invention is the ability to perform the volumetric estimation of a gas cloud volumetric estimation. This can be accomplished by using (instead of compensating or negating) the parallax -induced effects described above. In this case, the measured parallax between two or more similar spectral response images can be used to estimate a distance between the imaging system and the gas cloud or between the imaging system and an object in the field of view of the system. The parallax-induced transverse image shift d between two images is related to the distance z between the cloud or object and the imaging system according to $z = -sz'/d$, where s is the separation between two similar spectral response images, and z' is the distance to the image plane from the back lens (z' is typically approximately equal to the focal length f of the lens of the imaging system). Once the distance z between the cloud and the imaging system is calculated, the size of the gas cloud can be determined based on the magnification equation, $m = f/z$, where each image pixel on the gas cloud, $\Delta x'$, corresponds to a physical size in object space $\Delta x = \Delta x'/m$. To estimate the volume of the gas cloud, a particular symmetry in the thickness of the cloud based on the physical size of the cloud can be assumed. For example, the cloud image can be rotated about a central axis running through the cloud image to create a three dimensional volume estimate of the gas cloud size. It is worth noting that only a single imaging system of the invention is required for such volume estimation, in contradistinction with carrying out such estimate with a spectral imaging system of related art (in which case at least two imaging systems would be necessary). Indeed, due to the fact that the information about the angle at which the gas cloud is seen by the system is decoded in the parallax-effect, the image data includes the information about the imaged scene viewed by the system in association with at least two angles.

[00053] When the temporal differencing algorithm is used for processing the acquired imaging data, a change in the scene that is caused not by the target species is highlighted in the resulting image. According to an embodiment of the invention, compensation of this error makes use of the temporal differencing between two FPAs that are substantially equally spectrally sensitive to the target species. In this case, the temporal difference image will highlight those pixels the spectra of which have changed in time. Subtracting the data corresponding to these pixels at both FPAs to form the resulting image, therefore, excludes the contribution of the target species to the resulting image. The differentiation between (i) changes in the scene due to the presence of target species and (ii) changes in the scene caused by changes in the background not associated with the target species is, therefore, enabled. It

should be noted that, quite unexpectedly, the data acquired with the visible-light FPA (when present as part of the otherwise IR imaging system) can also be used to facilitate such differentiation and compensation of the motion-caused imaging errors. Visible cameras generally have much lower noise figure than IR cameras (at least during daytime). Consequently, the temporal difference image obtained with the use of image data from the visible-light FPA can be quite accurate. The visible FPA can be used to compensate for motion in the system as well as many potential false-alarms in the scene due to motion caused by people, vehicles, birds, and steam, for example, as long as the moving object can be observed in the visible region of the spectra. This has the added benefit of providing an additional level of false alarm suppression without reducing the sensitivity of the system since many targets such as gas clouds cannot be observed in the visible spectral region.

[00054] Another method for detection of the gases is to use a spectral unmixing approach. A spectral unmixing approach assumes that the spectrum measured at a detector pixel is composed of a sum of component spectra, and attempts to estimate the relative weights of these components needed to derive the measurement spectrum. The component spectra are generally taken from a predetermined spectral library (for example, from data collection that has been empirically assembled), though sometimes one can use the scene to estimate these as well (often called "endmember determination"). For the gas cloud detection, the component spectra include the absorption spectra of various gases of interest, while the "measurement spectrum" is not the raw measurement of spectral intensity values but rather an "absorption spectrum", which includes the spectrum of background light absorbed on transmission through a cloud. The spectral unmixing methodology can also benefit from temporal, parallax, and motion compensation techniques.

[00055] *Examples of Practical Embodiments and Operation.* The embodiment **300** of Fig. 3 was configured to employ 12 optical channels and 12 corresponding microbolometer FPAs as **336** and used to capture a video sequence (representing images of a standard laboratory scene) substantially immediately after performing calibration measurements with the use of a reference source including two shutters, as discussed above (one at room temperature and one 5°C above room temperature). The use of 12 FPAs offers a good chance of simultaneous detection and estimation of the concentrations of about 8 or 9 gases present at the scene, but the number of FPAs **336** can vary, depending on the balance between the operational requirements and consideration of cost.

[00056] Due to the specifics of operation in the IR range of the spectrum, the use of the so-called noise-equivalent temperature difference (or NETD) is preferred and is analogous to the SNR commonly used in visible spectrum instruments. The array of microbolometer FPAs

336 is characterized to perform at $\text{NETD} \leq 72 \text{ mK}$ at an f-number of 1.2. Each measurement was carried out by summing four consecutive frames, and the reduction in the NETD value expected due to such summation would be described by corresponding factor of $\sqrt[4]{4} = 2$. Under ideal measurement conditions, therefore, the FPA NETD should be about 36 mK.

[00057] The commercially off-the-shelf LP, SP, and/or BP filters were used as the filters **130**. Using the image data acquired at each FPA pixel, the processor of the system was used to calculate the mean value and the standard deviation of the image data across the video sequence, to form a data output representing a "mean image" and a "standard deviation image" of the scene.

[00058] Table 1 summarizes the "mean NETD" values obtained by averaging of the NETD values over all pixels of the standard deviation image", as well as the median NETD values obtained in a similar fashion, in degrees Celsius. The top section of Table 1 shows the results for the bandpass filters, the middle section of Table 1 shows the results for the LP and SP filters, and the bottom section of Table 1 presents data for differences between NETD values of two specified LP filters. (Note that no filter is treated as equivalent to a longpass filter here.)

[00059] The results of Table 1 indicate that the difference between the NETD values of the two chosen LP filters is substantially smaller than the NETD value corresponding to a single BP filter, thereby providing an experimental proof that the use of an embodiment of the invention as discussed above provides an unexpected increase in a SNR-type figure of merit of the IR spectral imaging in comparison with a system of related art. In other words, the use of two (or more) LP or SP filters to extract the imaging data results in a spectrally-narrowed imaging channel having a higher operational performance as compared with the use of a bandpass filter centered on the chose wavelength in the same spectral channel.

[00060] It is worth noting that the use of optically-filtered FPAs rather than a more conventional Fourier Transform spectrometer (FTS) in an embodiment of the invention is partly explained by a larger number of total pixels available with a single large format microbolometer FPA array. More importantly, however, the use of the FTS is well recognized to require tight mechanical tolerances, leading to sufficiently more complex assembly of the imaging system employing the FTS as compared to the assembly of the embodiment of the invention. Additionally, the FTS does not offer a high enough optical throughput for a substantially low number of optical channels (for example, between 4 and 50 optical channels) (in part because many of the sampled wavenumber values in the reconstructed spectrum do not correspond to regions of the spectrum that the FTS instrument is sensitive to, and so such sampled data is eventually discarded and not used for image

formation and detection of target species). The FTS is better suited to higher resolution spectroscopy. The problem with working with highly -resolved spectra, however, is that by sampling the same amount of incident light with smaller spectral bins means that image data corresponding each bin is actually noisier. Therefore, while improved spectral resolution accorded by the FTS can allow the user to pick locations in the spectrum that are highly specific to the absorption/emission signature of the target species, it also makes such signature weaker relative to the detection noise.

[00061] A major advantage of the embodiments of the present system over instruments of the related art that are configured for target species detection (for example, gas cloud detection) is that, according to the present invention, the entire spectrum is resolved in a snapshot mode (for example, during one image frame acquisition by the FPA array). This enables the system of the invention to take advantage of the compensation algorithms such as the parallax and motion compensation algorithms mentioned above. Indeed, as the imaging data required to implement these algorithms are collected simultaneously with the target-species related data, the compensation algorithms are carried out with respect to target-species related data and not with respect to data acquired at another time interval, thereby ensuring accuracy of the data compensation process. In addition, the frame rate of data acquisition is much higher (the present system operates at up to video rates; from about 5 Hz and higher, for example), so that the user is enabled to recognize in the images the wisps and swirls typical of gas mixing without blurring out of these dynamic image features and other artifacts caused by the change of scene (whether spatial or spectral) during the lengthy measurements. In contradistinction with the imaging systems of the related art that require image data acquisition over a period of time exceeding a single-snap-shot time and, therefore, blur the target gas features in the image and inevitably reduce the otherwise achievable sensitivity of the detection, embodiments of the present invention make detecting the localized concentrations of gas without it being smeared out and/or averaged with the areas of thinner gas concentrations. In addition, the higher frame rate also enables a much faster response rate to a leak of gas (when detecting such leak is the goal): an alarm can trigger within fractions of a second rather than several seconds.

[00062] Table 1:

filter	NETD (degC)	
	mean	median
BP-8224	0.691	0.675
BP-9000	0.938	0.923
BP-9480	0.318	0.315
BP-9740	0.372	0.369
BP-10240	0.275	0.286
BP-10700	0.409	0.405
BP-10962	0.44	0.437
BP-11660	0.548	0.542
BP-12227	0.48	0.475
BP-13289	1.309	1.26
[none]	0.038	0.037
LP-8110	0.063	0.063
LP-8500	0.076	0.075
LP-8110	0.068	0.067
LP-8305	0.068	0.067
LP-8500	0.08	0.08
LP-9000	0.073	0.073
LP-9650	0.099	0.098
LP-9800	0.109	0.108
LP-11000	0.156	0.156
LP-11450	0.207	0.206
SP-10500	0.07	0.07
[none] - [LP-8110]	0.07	(i.e.methane)
[LP-9650] - [LP-11450]	0.208	(i.e. propylene)
[LP-9800] - [LP-11000]	0.227	(i.e. butane)

[00063] To demonstrate the operation and gas detection capability of an embodiment of the invention, a prototype was constructed in accordance with the embodiment **300** of Fig. 3A and used to detect a hydrocarbon gas cloud of propylene at a distance of approximately 10 feet. Fig. 7 illustrates video frames 1 through 12 representing gas-cloud-detection output **710** (seen as a streak of light) in a sequence from $t=1$ to $t=12$. The images 1 through 12 are selected frames taken from a video-data sequence captured at a video-rate of 15 frames/sec. The detected propylene gas is shown as a streak of light **710** (highlighted in red) near the center of each image. The first image is taken just prior to the gas emerging from the nozzle of a gas-contained, while the last image represents the system output shortly after the nozzle has been turned off.

[00064] Using the same prototype of the system, the demonstration of the dynamic calibration improvement described above by imaging the scene surrounding the system (the laboratory) with known temperature differences. The result of implementing the dynamic correction procedure is shown in Figs. 8A, 8B, where the curves labeled "obj" (or "A") represent temperature estimates of an identified region in the scene. The abscissa in each of the plots of Figs. 8A, 8B indicates the number of a detector element, while the ordinate corresponds to temperature (in degrees C). Accordingly, it is expected that when all detector elements receive radiant data that, when interpreted as the object's temperature, indicates that the object's temperature perceived by all detector elements is the same, any given curve would be a substantially flat line. Data corresponding to each of the multiple "obj" curves are taken from a stream of video frames separated from one another by about 0.5 seconds (for a total of 50 frames). The recorded "obj" curves shown in Fig. 8A indicate that the detector elements disagree about the object's temperature, and that difference in object's temperature perceived by different detector elements is as high as about 2.5°C. In addition, all of the temperature estimates are steadily drifting in time, from frame to frame. The curves labelled "ref" (or "C") correspond to the detectors' estimates of the temperature of the aperture **338** of the embodiment **300** of Fig. 3A. The results of detection of radiation carried out after each detector pixel has been subjected to the dynamic calibration procedure described above are expressed with the curved labeled "obj corr" (or "B"). Now, the difference in estimated temperature of the object among the detector elements is reduced to about 0.5°C (thereby improving the original reading at least by a factor of 5).

[00065] Fig. 8B represents the results of similar measurements corresponding to a different location in the scene (a location which is at a temperature about 9°C above the estimated temperature of the aperture **338** of Fig. 3A). As shown, the correction algorithm discussed above is operable and effective and applicable to objects kept at different temperature. Accordingly, the algorithm is substantially temperature independent.

[00066] At least some elements of a device of the invention can be controlled - and at least some steps of a method of the invention can be effectuated, in operation - with a programmable processor governed by instructions stored in a memory. The memory may be random access memory (RAM), read-only memory (ROM), flash memory or any other memory, or combination thereof, suitable for storing control software or other instructions and data. Those skilled in the art should also readily appreciate that instructions or programs defining the functions of the present invention may be delivered to a processor in many forms, including, but not limited to, information permanently stored on non-writable storage media (e.g. read-only memory devices within a computer, such as ROM, or devices readable by a computer I/O attachment, such as CD-

ROM or DVD disks), information alterably stored on writable storage media (e.g. floppy disks, removable flash memory and hard drives) or information conveyed to a computer through communication media, including wired or wireless computer networks. In addition, while the invention may be embodied in software, the functions necessary to implement the invention may optionally or alternatively be embodied in part or in whole using firmware and/or hardware components, such as combinatorial logic, Application Specific Integrated Circuits (ASICs), Field-Programmable Gate Arrays (FPGAs) or other hardware or some combination of hardware, software and/or firmware components.

[00067] While examples of embodiments of the system and method of the invention have been discussed in reference to the gas-cloud detection, monitoring, and quantification (including but not limited to greenhouse gases such as Carbon Dioxide, Carbon Monoxide, Nitrogen Oxide as well as hydrocarbon gases such as Methane, Ethane, Propane, n-Butane, iso-Butane, n-Pentane, iso-Pentane, neo-Pentane, Hydrogen Sulfide, Sulfur Hexafluoride, Ammonia, Benzene, p- and m-Xylene, Vinyl chloride, Toluene, Propylene oxide, Propylene, Methanol, Hydrazine, Ethanol, 1,2-dichloroethane, 1,1-dichloroethane, Dichlorobenzene, Chlorobenzene, to name just a few), embodiments of the invention can be readily adapted for other chemical detection applications. For example, detection of liquid and solid chemical spills, biological weapons, tracking targets based on their chemical composition, identification of satellites and space debris, ophthalmological imaging, microscopy and cellular imaging, endoscopy, mold detection, fire and flame detection, and pesticide detection are within the scope of the invention.

CLAIMS:

1. An infrared (IR) imaging system for imaging a target species in an object comprising a gas cloud, the imaging system comprising:
 - an optical system comprising an optical focal plane array (FPA) unit and defining a plurality of spatially and spectrally different optical channels to transfer IR radiation towards the optical FPA unit, each optical channel of the plurality of optical channels positioned to transfer a portion of the IR radiation incident on the optical system from the object towards the optical FPA unit; and
 - a processor configured to acquire, in a single occurrence of data acquisition, multispectral optical data representing in spatial (x, y) and spectral (λ) coordinates said object and said target species from the IR radiation received at the optical FPA unit.
2. The system of Claim 1, wherein the multispectral data comprises a number of spectrally different images of the object, each spectrally different image comprising IR image data transferred to the optical FPA unit by a corresponding optical channel.
3. The system of Claims 1 or 2, further comprising an optical filter corresponding to a particular optical channel and configured to transmit the portion of IR radiation towards the optical FPA unit.
4. The system of Claim 3, wherein the optical filter includes one of a longpass optical filter and a shortpass optical filter.
5. The system of Claim 3 or 4, further comprising one or more front objective lenses.
6. The system of any one of Claims 1-5, wherein the optical system comprises a plurality of lenses, each lens corresponding to an optical channel.

7. The system of Claim 6, wherein each optical channel is defined at least in part by a corresponding filter and a corresponding lens.
8. The system of Claim 6 or 7, wherein the plurality of lenses comprises a lens array.
9. The system of any one of Claims 6-8, further comprising a plurality of relay lenses configured to relay the IR radiation along the optical channels.
10. The system of any one of Claims 6-9, further comprising one or more moveable temperature-controlled shutters removably positioned to block IR radiation incident onto the optical system from reaching the optical FPA unit.
11. The system of any one of Claims 1-10, wherein the multispectral optical data from the plurality of optical channels is captured substantially simultaneously by the optical FPA unit.
12. The system of any one of Claims 1-11, wherein the multispectral optical data from the plurality of optical channels is captured during one image frame acquisition by the optical FPA unit.
13. The system of any one of Claims 1-12, further comprising first and second temperature-controlled moveable elements removably positioned to block IR radiation incident onto the optical system from reaching the optical FPA unit.
14. The system of any one of Claims 1-13, wherein the optical FPA unit is devoid of a cooling device.
15. The system of any one of Claims 1-14, further comprising a filter array.
16. The system of any one of Claims 1-15, wherein the processor is configured to acquire said optical data from two or more sets of imaging data.

17. The system of Claim 16, wherein the processor is configured to process the acquired optical data to compensate for parallax-induced differences between the two or more sets of imaging data.
18. The system of Claim 16 or 17, wherein the processor is configured to process the acquired optical data to compensate for differences between the two or more sets of imaging data induced by changes in the object that are not associated with the target species.
19. The system of any one of Claims 16-18, wherein the processor is configured to process the acquired optical data to generate a temporal reference image.
20. The system of Claim 19, wherein the processor is configured to use the temporal reference image to generate a temporal difference image.
21. The system of any one of Claims 16-20, wherein the processor is configured to process the acquired optical data to estimate a volume of a gas cloud.
22. The system of any one of Claims 16-21, wherein the processor is configured to process the multispectral optical data using spectral unmixing.
23. The system of any one of Claims 1-22, wherein the optical FPA unit includes a bolometer configured to operate without being cooled.
24. The system of any one of Claims 1-23, further comprising a field reference for dynamically adjusting data output from the optical FPA unit.
25. The system of Claim 24, wherein the field reference comprises an array of field stops.

26. The system of Claim 24 or 25, wherein the field reference comprises a uniform temperature across its surface and is characterized by a predetermined spectral curve of radiation emanating therefrom.
27. The system of any one of Claims 24-26, wherein the field reference is adapted to obscure or block a peripheral portion of the IR radiation propagating from the object towards the optical FPA unit.
28. The system of any one of Claims 1-27, further comprising a visible light imaging sensor.
29. The system of Claim 28, wherein the processor is configured to process data received from the visible light imaging sensor to compensate for motion-induced imaging errors.
30. The system of any one of Claims 1-29, wherein the processor is configured to construct, in the single occurrence of data acquisition, a multispectral data cube of the object, the multispectral data cube comprising a number of spectrally different IR images of the object, each spectrally different IR image comprising IR image data transferred to the optical FPA unit by a corresponding optical channel.
31. The system of any one of Claims 1-30, wherein the portion of the IR radiation corresponds to a region of wavelengths of the spectrum of wavelengths, the region of wavelengths at least partially overlapping another region of wavelengths transferred by another optical channel.
32. The system of any one of Claims 1-31, wherein the processor comprises a programmable processor configured to execute instructions stored in a tangible, non-transitory computer-readable storage medium.

33. An infrared (IR) imaging system, the imaging system comprising:
at least four spatially and spectrally different optical channels configured to receive IR radiation from a common object comprising a gas cloud, each of the at least four spatially and spectrally different optical channels comprising at least one imaging lens configured to image the object on a Focal Plane Array (FPA) unit; and
processing electronics in communication with the FPA unit,
wherein said infrared system is configured to:
acquire multispectral optical data from the at least four spatially and spectrally different optical channels; and
process the multispectral optical data to detect one or more target species present in the object.
34. The system of Claim 33, further comprising twelve optical channels.
35. The system of Claim 33 or 34, configured to simultaneously acquire multispectral optical data from the at least four spatially and spectrally different optical channels.
36. The system of any one of Claims 33-35, further comprising a plurality of optical filters associated with the optical channels.
37. The system of Claim 36, wherein the number of optical filters is two.
38. The system of Claim 36, wherein the number of optical filters is three.
39. The system of Claim 36, wherein the number of optical filters is four.
40. The system of Claim 36, wherein the plurality of optical filters comprise at least one long pass (LP) filter.

41. The system of Claim 36, wherein the plurality of optical filters comprise multiple long pass (LP) filters.
42. The system of Claim 36, wherein the plurality of optical filters comprise at least one short pass (SP) filter.
43. The system of Claim 36, wherein the plurality of optical filters comprise multiple short pass (SP) filters.
44. The system of Claim 36, wherein the plurality of optical filters comprise at least one band pass (BP) filter.
45. The system of Claim 36, wherein the plurality of optical filters comprise at least one short pass (SP) filter and one long pass (LP) filter.
46. The system of any one of Claims 33-45, wherein the FPA unit comprises a plurality of FPAs.
47. The system of any one of Claims 33-46, further comprising first and second temperature-controlled elements removably positioned to block IR radiation incident on the imaging system from reaching the FPA unit.
48. The system of any one of Claims 33-47, further comprising a field reference configured for dynamically calibrating a plurality of the FPAs in the FPA unit.
49. The system of any one of Claims 33-48, wherein the field reference is configured to obscure a peripheral region of an image generated by a plurality of the FPAs in the FPA unit.
50. The system of any one of Claims 33-49, configured to compare spectral data in at least one of the four optical channels acquired at a first instant of time with spectral data in the

at least one of the four optical channels acquired at a second instant of time to generate a temporal difference image.

51. The system of Claim 33, configured to use a difference between the multispectral optical data acquired by two optical channels of the at least four spatially and spectrally different optical channels to correct parallax-induced imaging errors.

52. The system of any one of Claims 33-51, configured to compare spectral data in one of the at least four optical channels with spectral data in another one of the at least four optical channels to generate a spectral difference image.

53. The system of any one of Claims 33-52, further comprising a visible light imaging sensor.

54. The system of Claim 53, configured to use the visible light imaging sensor to compensate for motion-induced imaging errors.

55. The system of any one of Claims 33-54, configured to process the multispectral optical data using spectral unmixing.

56. The system of any one of Claims 33-55, wherein the processing electronics comprises one or more processors.

57. The system of any one of Claims 33-56, further comprising a thermal reference configured to be imaged onto the FPA unit such that a plurality of frames of the acquired multispectral optical data has an image of the thermal reference source.

58. The system of any one of Claims 33-57, wherein each optical channel is configured to transfer spectrally distinct, two-dimensional image data of the common object to one or more imaging sensors.

59. An infrared (IR) imaging system, the imaging system comprising:
a plurality of spatially and spectrally different optical channels, at least some of the plurality of optical channels configured to receive IR radiation from a common object, each of the plurality of spatially and spectrally different optical channels comprising at least one imaging lens configured to image the object on a Focal Plane Array (FPA) unit; and
processing electronics in communication with the FPA unit,
wherein said infrared system is configured to:
acquire multispectral optical data from the plurality of different optical channels; and
process the multispectral optical data to detect one or more target species present in the object, and
wherein the system is further configured to compare spectral data in at least one of the plurality of optical channels acquired at a first instant of time with spectral data in at least one of the plurality of optical channels acquired at a second instant of time to generate a temporal difference image.

60. An infrared (IR) imaging system, the imaging system comprising:
a plurality of spatially and spectrally different optical channels, at least some of the plurality of optical channels configured to receive IR radiation from a common object, each of the plurality of spatially and spectrally different optical channels comprising at least one imaging lens configured to image the object on a Focal Plane Array (FPA) unit; and
processing electronics in communication with the FPA unit,
wherein said infrared system is configured to:
acquire multispectral optical data from the plurality of different optical channels; and
process the multispectral optical data to detect one or more target species present in the object, and
wherein the system is configured to use a difference between the multispectral optical data acquired by two optical channels to correct parallax-induced imaging errors.

61. The system of Claim 60, wherein spectral characteristics of the two optical channels are identical.

62. An infrared (IR) imaging system, the imaging system comprising:
a plurality of spatially and spectrally different optical channels, at least some of the plurality of optical channels configured to receive IR radiation from a common object, each of the plurality of spatially and spectrally different optical channels comprising at least one imaging lens configured to image the object on a Focal Plane Array (FPA) unit;
a visible light imaging sensor; and
processing electronics in communication with the FPA unit,
wherein said infrared system is configured to:
acquire multispectral optical data from the plurality of different optical channels; and
process the multispectral optical data to detect one or more target species present in the object.

63. An infrared (IR) imaging system, the imaging system comprising:
a plurality of spatially and spectrally different optical channels, at least some of the plurality of optical channels configured to receive IR radiation from a common object, each of the plurality of spatially and spectrally different optical channels comprising at least one imaging lens configured to image the object on a Focal Plane Array (FPA) unit; and
processing electronics in communication with the FPA unit,
wherein said infrared system is configured to:
acquire multispectral optical data from the plurality of different optical channels; and
process the multispectral optical data to detect one or more target species present in the object, and
wherein the system is configured to compensate for motion-induced imaging errors.

64. An infrared (IR) imaging system, the imaging system comprising:
a plurality of spatially and spectrally different optical channels, at least some of the plurality of optical channels configured to receive IR radiation from a common object, each of the plurality of spatially and spectrally different optical channels comprising at least one imaging lens configured to image the object on a Focal Plane Array (FPA) unit; and
processing electronics in communication with the FPA unit,
wherein said infrared system is configured to:
acquire multispectral optical data from the plurality of different optical channels; and
process the multispectral optical data to detect one or more target species present in the object by using spectral unmixing.
65. An infrared (IR) imaging system, the imaging system comprising:
an optical system including an optical focal plane array (FPA) unit, the optical system comprising components associated with at least two optical channels spatially and spectrally different from one another, each of the at least two optical channels positioned to transfer IR radiation from an object incident on the optical system towards the optical FPA unit, the optical FPA unit comprising at least two detectors disposed at a distance from two corresponding focusing lenses; and
a data-processing unit configured to obtain a spectral difference image by comparing images obtained by the at least two detectors, said infrared imaging system configured to identify a target species based on said spectral difference image.
66. The imaging system of Claim 65, wherein the imaging system is further configured to identify target species based on a comparison of a first spectral difference image and a second spectral difference image, said second spectral difference image acquired by the at least two detectors at a later time from the first spectral difference image.
67. The imaging system of Claim 65, wherein the FPA unit does not require cooling during normal operation.

68. The imaging system of Claim 65, wherein the IR radiation comprises wavelengths between about 1 micron and about 20 microns.
69. The imaging system of Claim 65, wherein the object comprises a gas cloud.
70. The imaging system of Claim 65, wherein the components associated with the at least two optical channels comprise at least two spectral filters, each filter positioned in a respective one of said at least two optical channels.
71. The imaging system of Claim 70, wherein the at least two spectral filters comprise at least one long pass (LP) filter.
72. The imaging system of Claim 70, wherein the at least two spectral filters comprise at least one short pass (SP) filter.
73. The imaging system of Claim 65, further comprising a movable temperature reference at a known temperature configured to be inserted into an optical path from the object to the FPA unit along at least one of the two optical channels to block IR radiation and configured to be removed from the optical path.
74. The system of Claim 73, wherein the data-processing unit is configured to calibrate the FPA unit based on the known temperature.
75. The imaging system of Claim 73, wherein the movable temperature reference comprises a first shutter at a first temperature and a second shutter at a second temperature.
76. The imaging system of Claim 73, wherein the movable temperature reference comprises a system having a first portion at a first temperature and a second portion at a second temperature.

77. The imaging system of Claim 65, wherein at least one of the two detectors comprises a microbolometer.

78. The imaging system of Claim 65, wherein the data-processing unit is configured to obtain the spectral difference image by subtracting images obtained by the at least two detectors, said images obtained by the at least two detectors having different spectral characteristics.

79. The imaging system of Claim 78, wherein the data-processing unit is configured to compare the obtained spectral difference image with a reference image.

80. The imaging system of Claim 79, wherein the reference image is obtained at a time interval prior to a time interval when the spectral difference image is obtained.

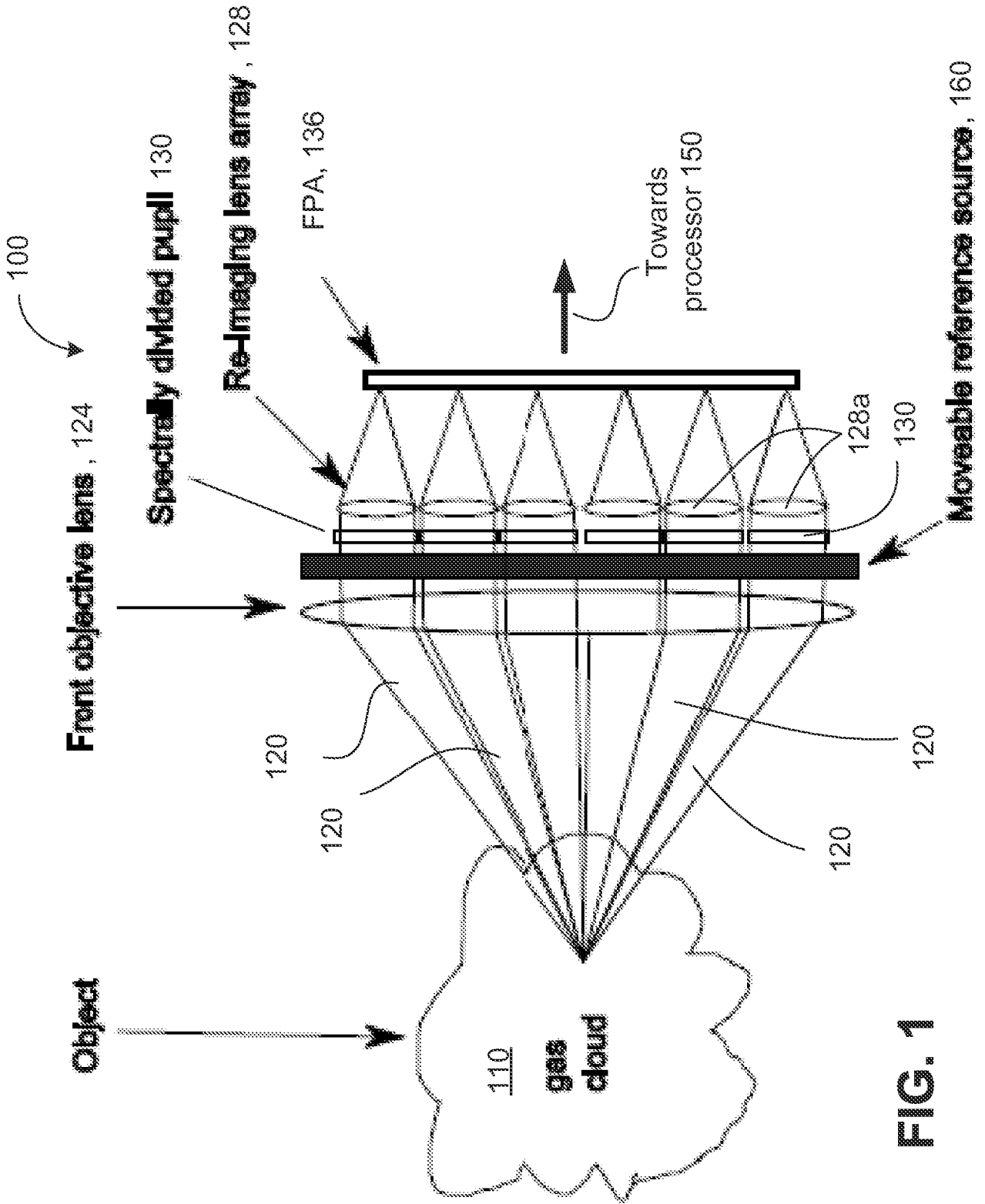

FIG. 1

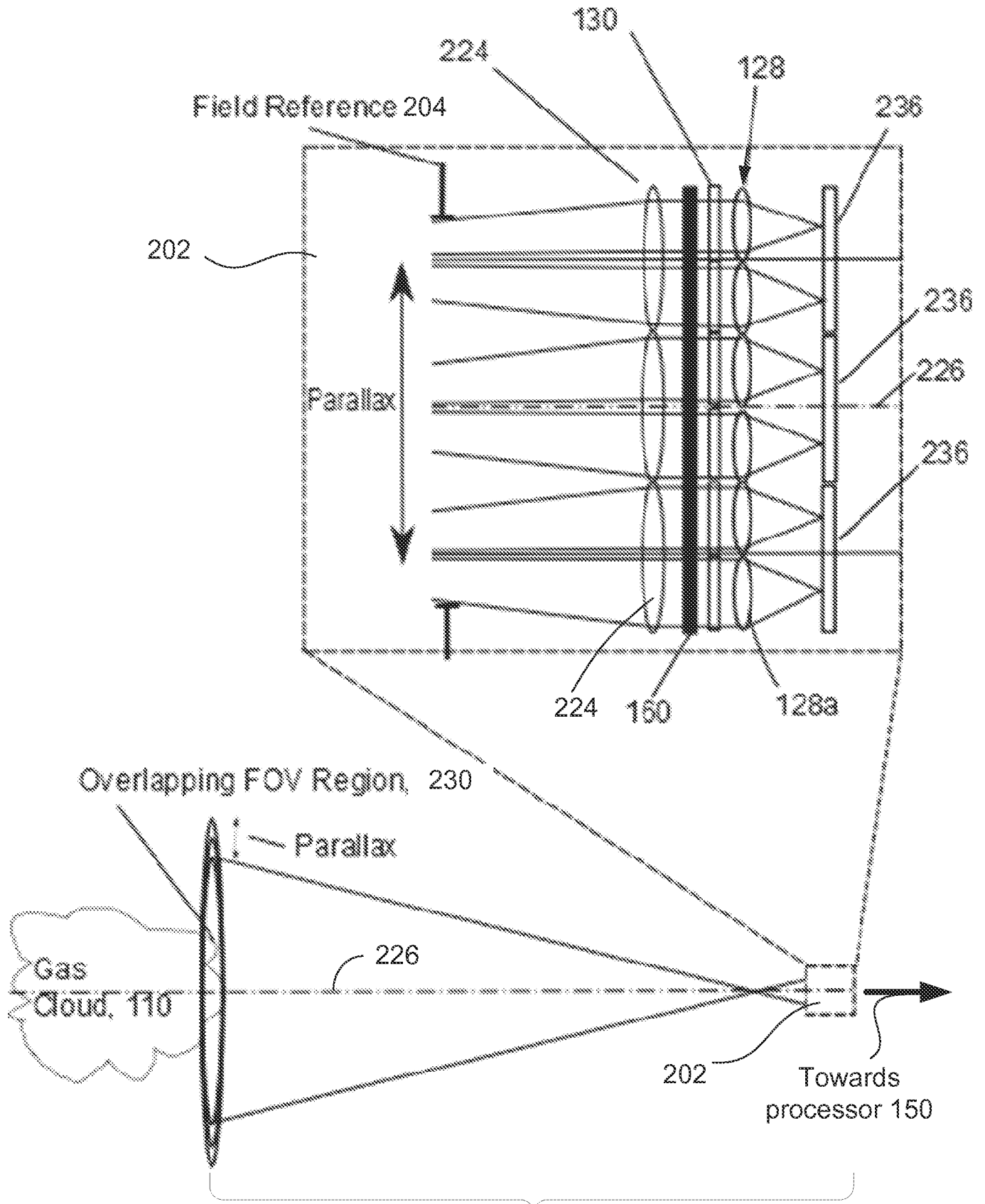
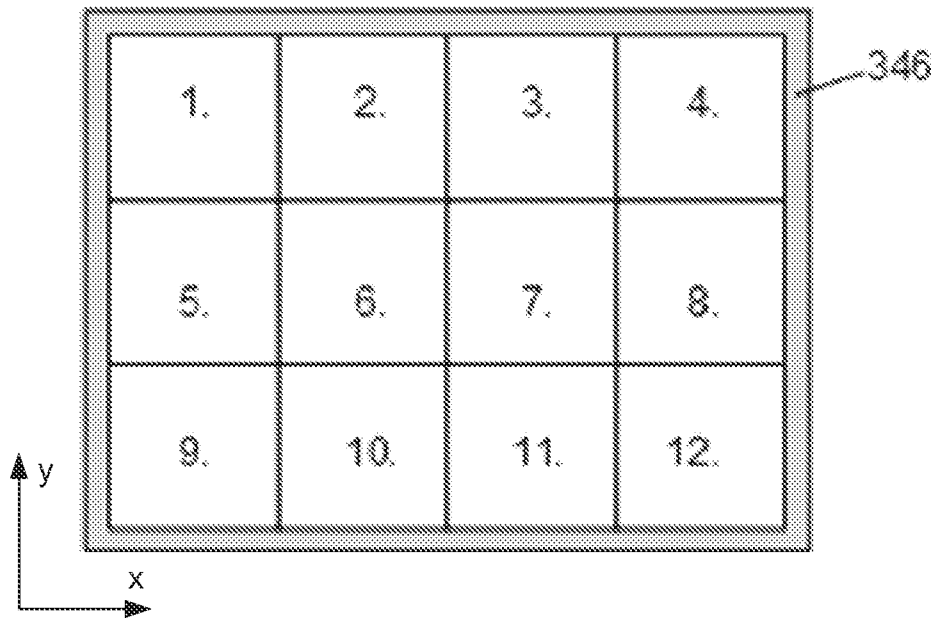
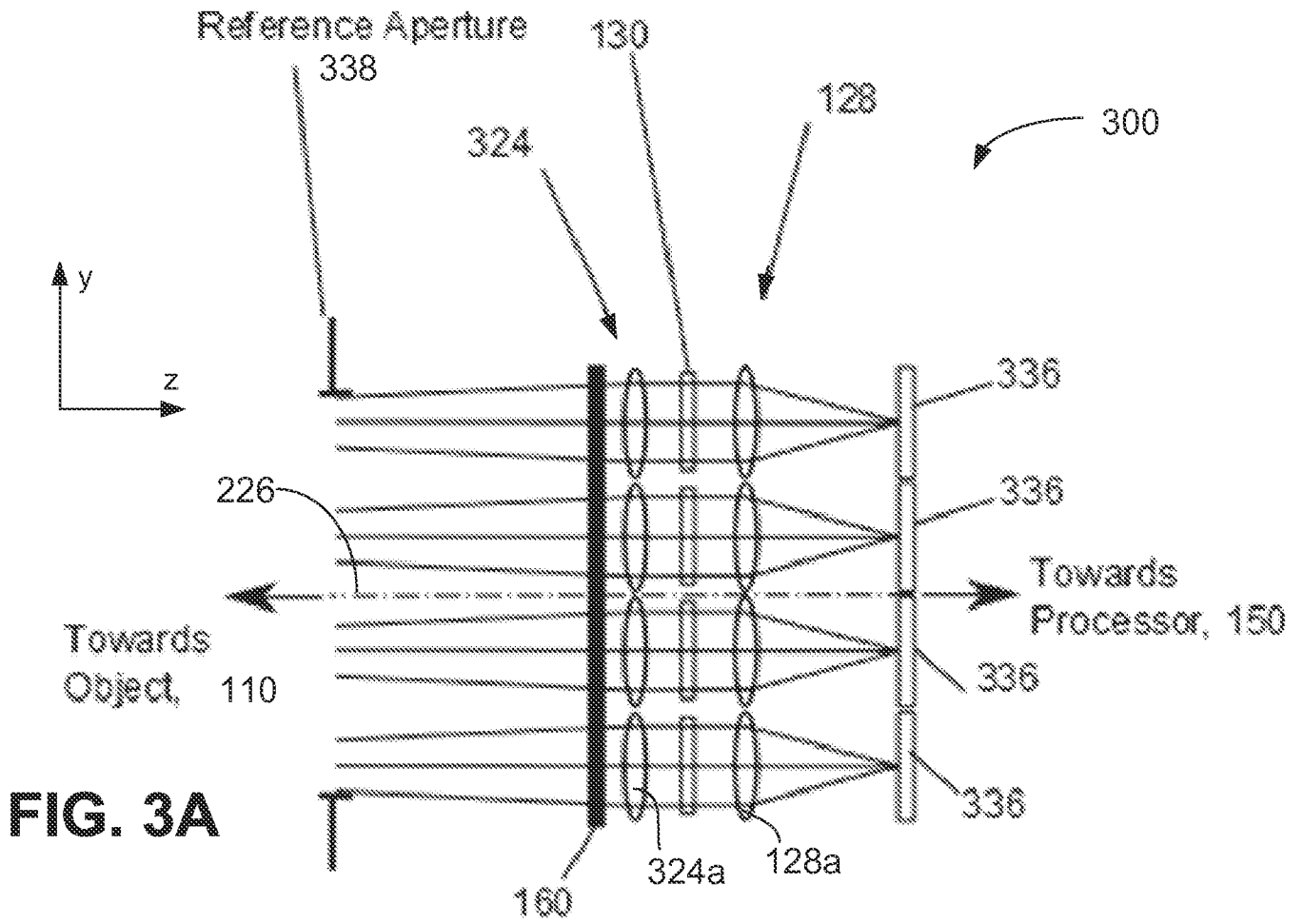

FIG. 2

200



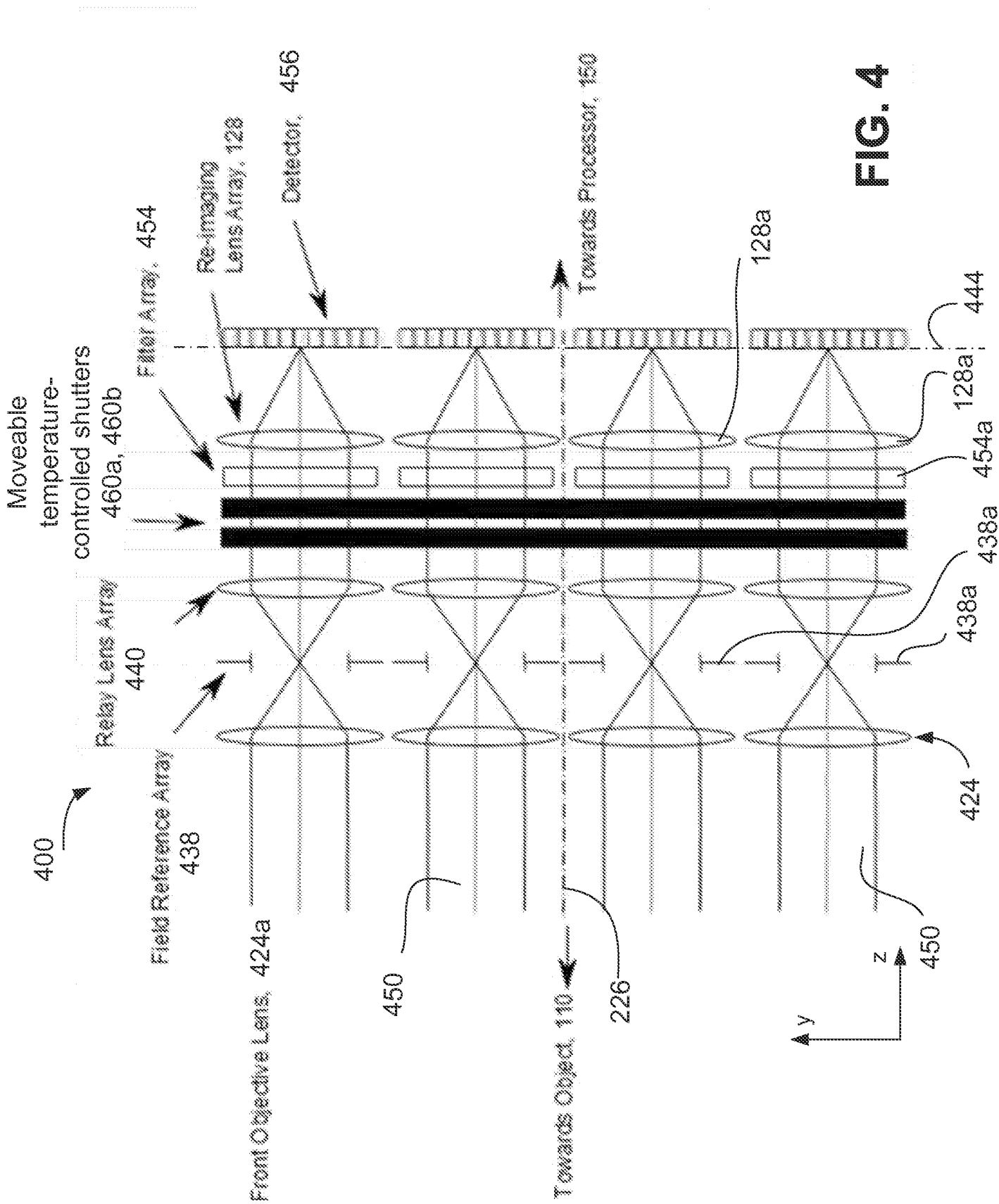

FIG. 4

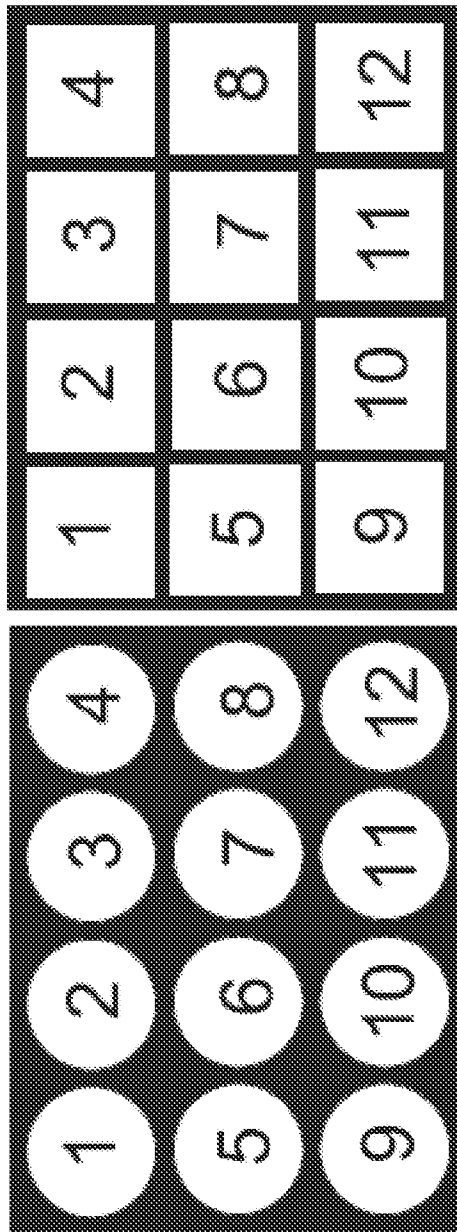

FIG. 5B

FIG. 5A

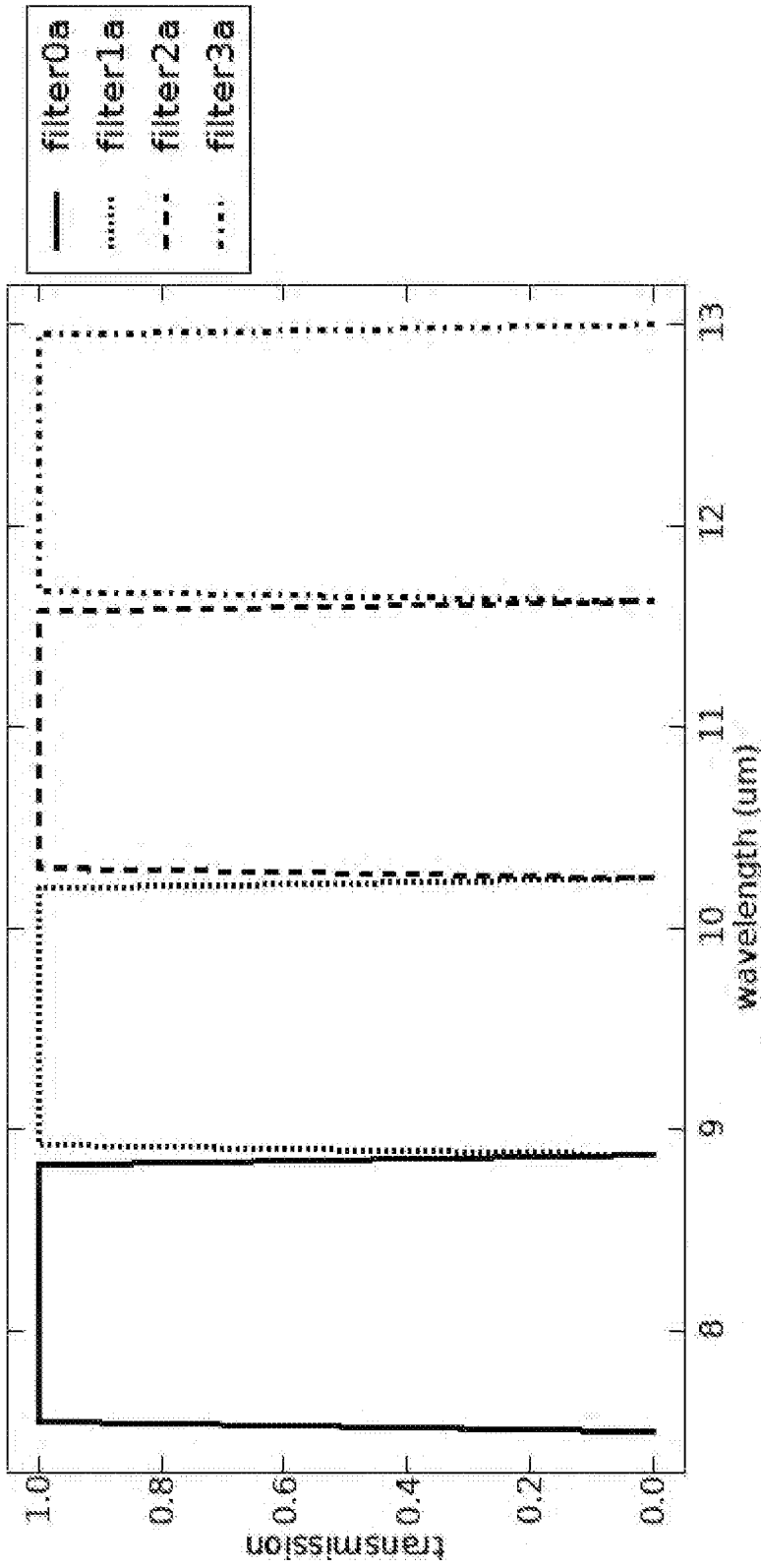

FIG. 6A

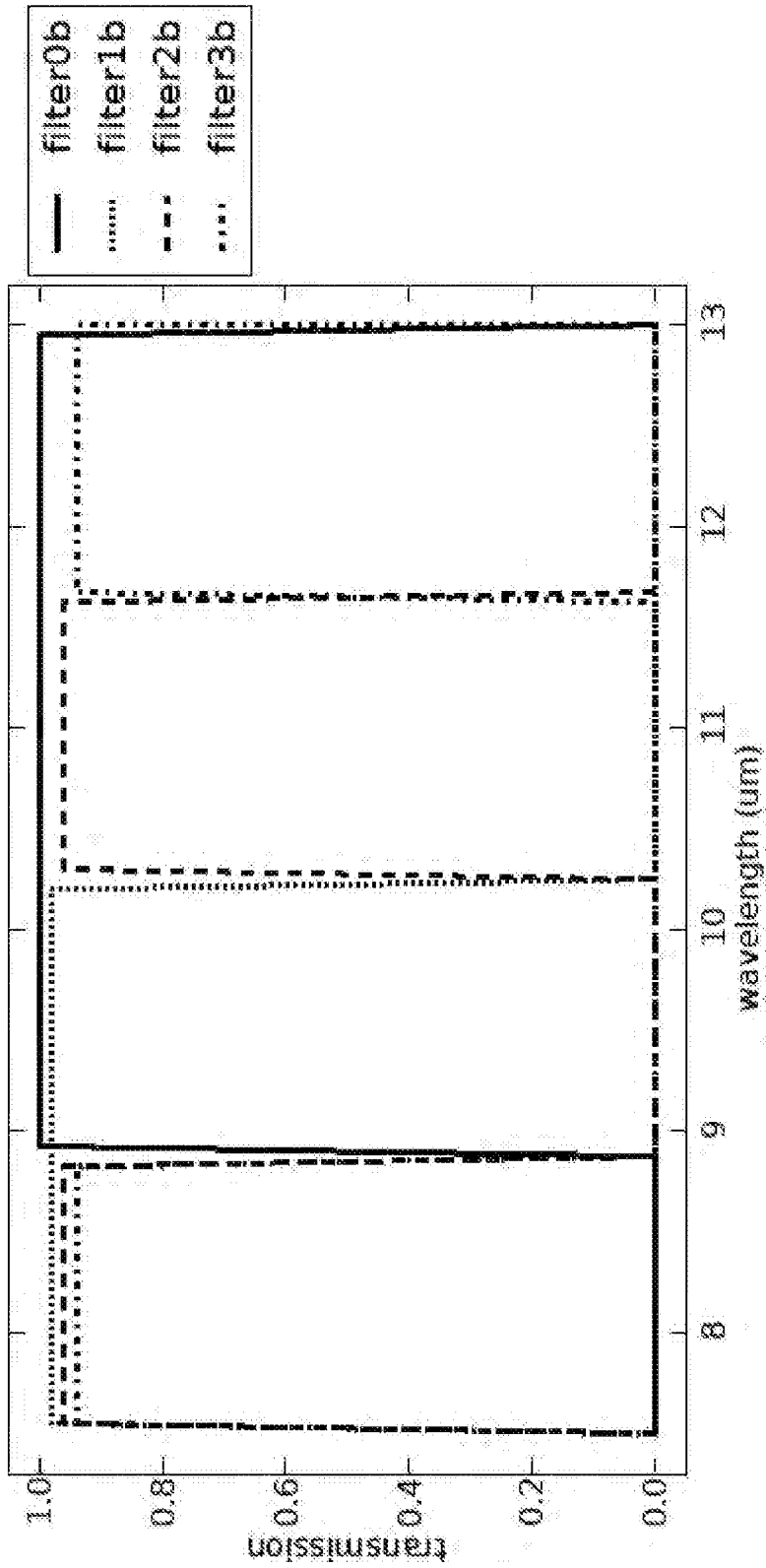

FIG. 6B

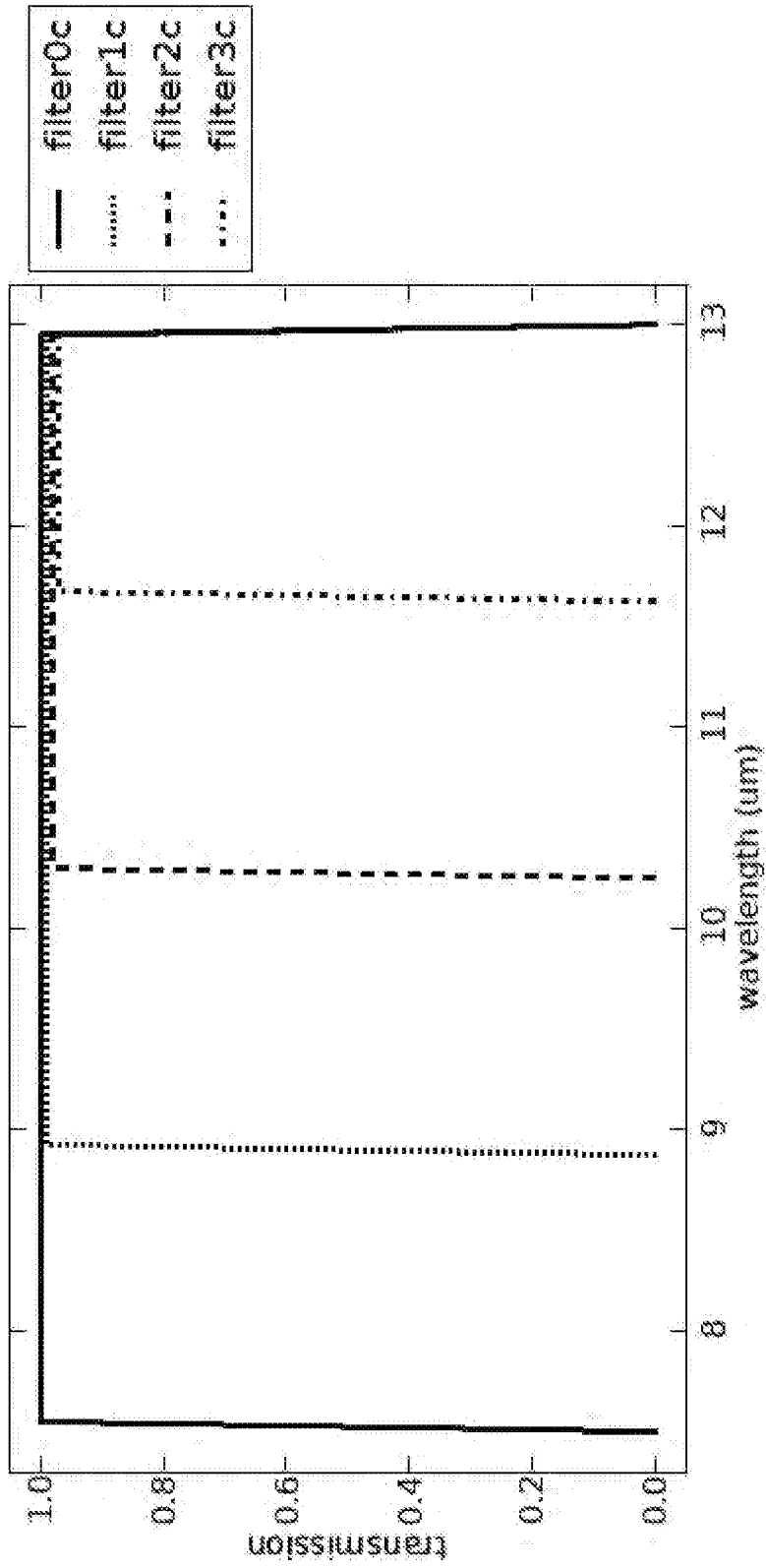

FIG. 6C

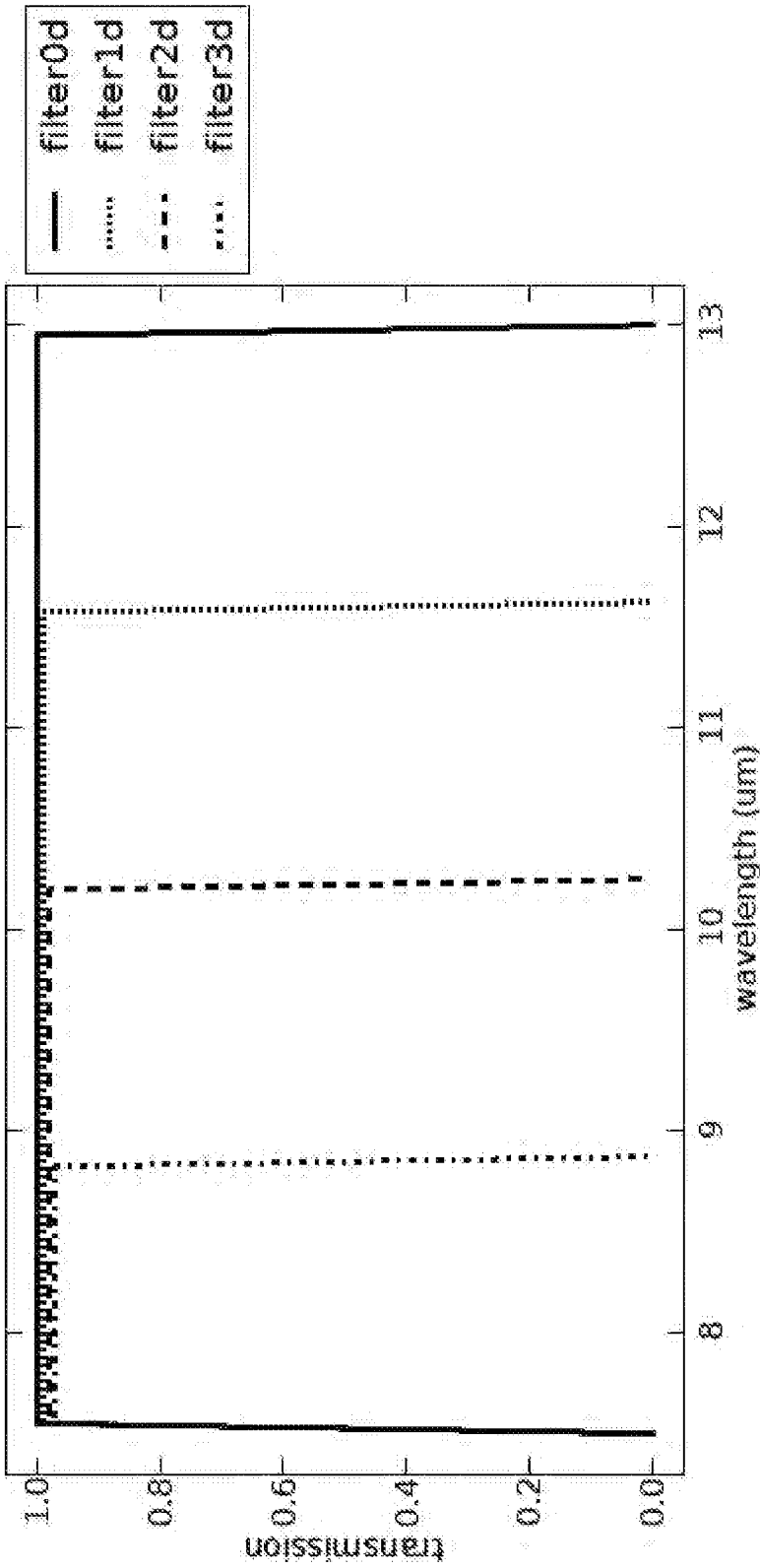

FIG. 6D



FIG. 7

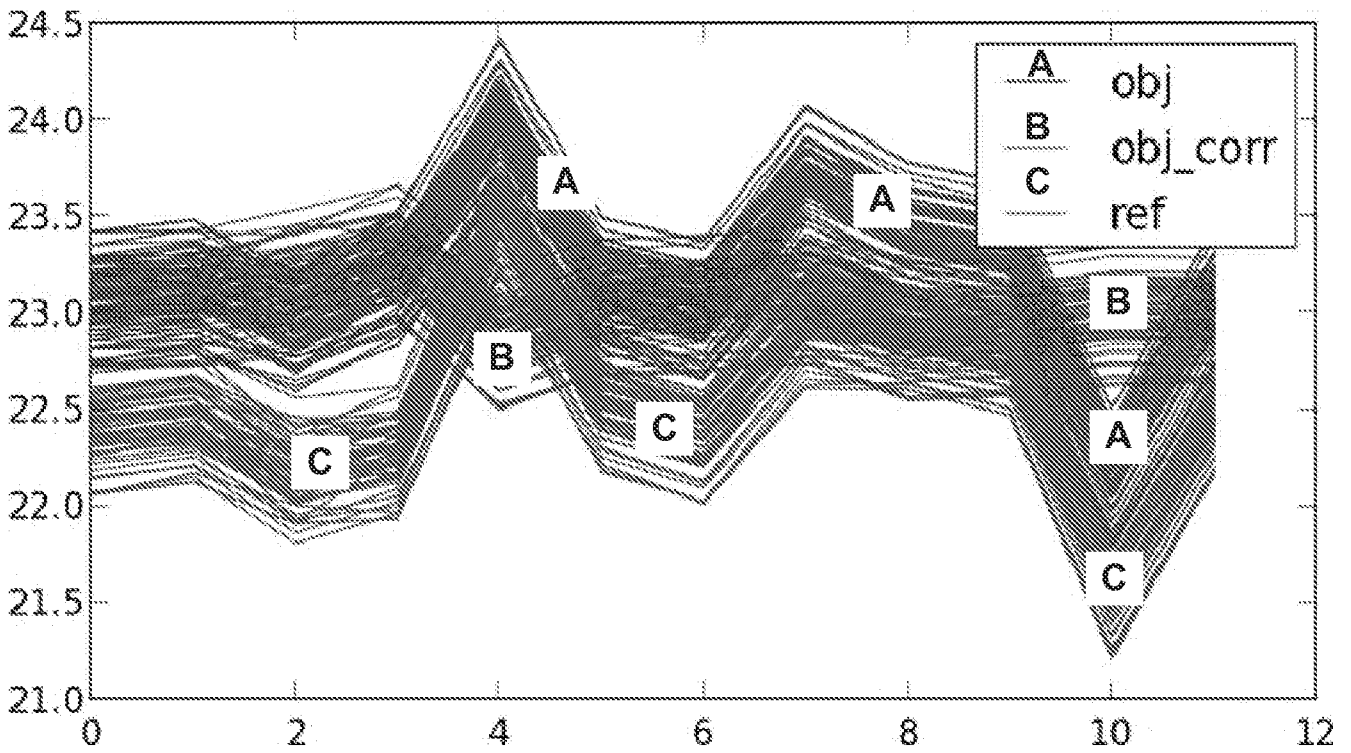

FIG. 8A

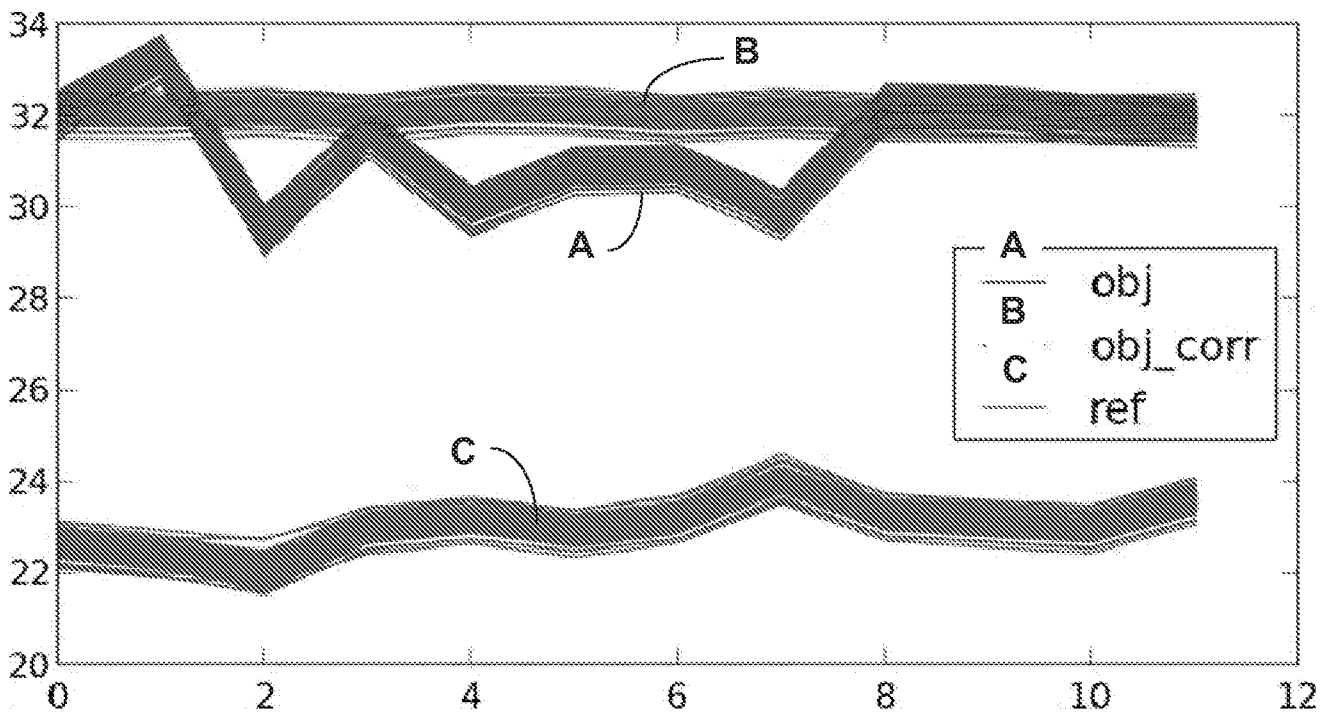

FIG. 8B

