



- (51) International Patent Classification:
G06Q 10/08 (2012.01) G06Q 50/28 (2012.01)
- (21) International Application Number:
PCT/US2018/030672
- (22) International Filing Date:
02 May 2018 (02.05.2018)
- (25) Filing Language: English
- (26) Publication Language: English
- (30) Priority Data:
62/500,461 02 May 2017 (02.05.2017) US
- (71) Applicant: **BXB DIGITAL PTY LIMITED** [AU/AU];
Level 10, Angel Place, 123 Pitt Street, Sidney, New South
Wales 2000 (AU).
- (72) Inventors; and
(71) Applicants: **SOUDER, Michael** [US/US]; 800 West El
Camino Real, Suite 180, Mountain View, California 94040
(US). **DAIGLE, Ryan** [US/US]; 800 West El Camino Re-
al, Suite 180, Mountain View, California 94040 (US). **JA-**

YARAMAN, Shankar [US/US]; 800 West El Camino
Real, Suite 180, Mountain View, California 94040 (US).
VALAME, Raj [US/US]; 800 West El Camino Real, Suite
180, Mountain View, California 94040 (US).

(74) Agent: **BAKER, Amanda Y.** et al.; Kilpatrick Townsend &
Stockton LLP, Mailstop: IP Docketing - 22, 1100 Peachtree
Street, Suite 2800, Atlanta, Georgia 30309 (US).

(81) Designated States (unless otherwise indicated, for every
kind of national protection available): AE, AG, AL, AM,
AO, AT, AU, AZ, BA, BB, BG, BH, BN, BR, BW, BY, BZ,
CA, CH, CL, CN, CO, CR, CU, CZ, DE, DJ, DK, DM, DO,
DZ, EC, EE, EG, ES, FI, GB, GD, GE, GH, GM, GT, HN,
HR, HU, ID, IL, IN, IR, IS, JO, JP, KE, KG, KH, KN, KP,
KR, KW, KZ, LA, LC, LK, LR, LS, LU, LY, MA, MD, ME,
MG, MK, MN, MW, MX, MY, MZ, NA, NG, NI, NO, NZ,
OM, PA, PE, PG, PH, PL, PT, QA, RO, RS, RU, RW, SA,
SC, SD, SE, SG, SK, SL, SM, ST, SV, SY, TH, TJ, TM, TN,
TR, TT, TZ, UA, UG, US, UZ, VC, VN, ZA, ZM, ZW.

(84) Designated States (unless otherwise indicated, for every
kind of regional protection available): ARIPO (BW, GH,

(54) Title: SYSTEMS AND METHODS FOR FACILITY MATCHING AND LOCALIZATION

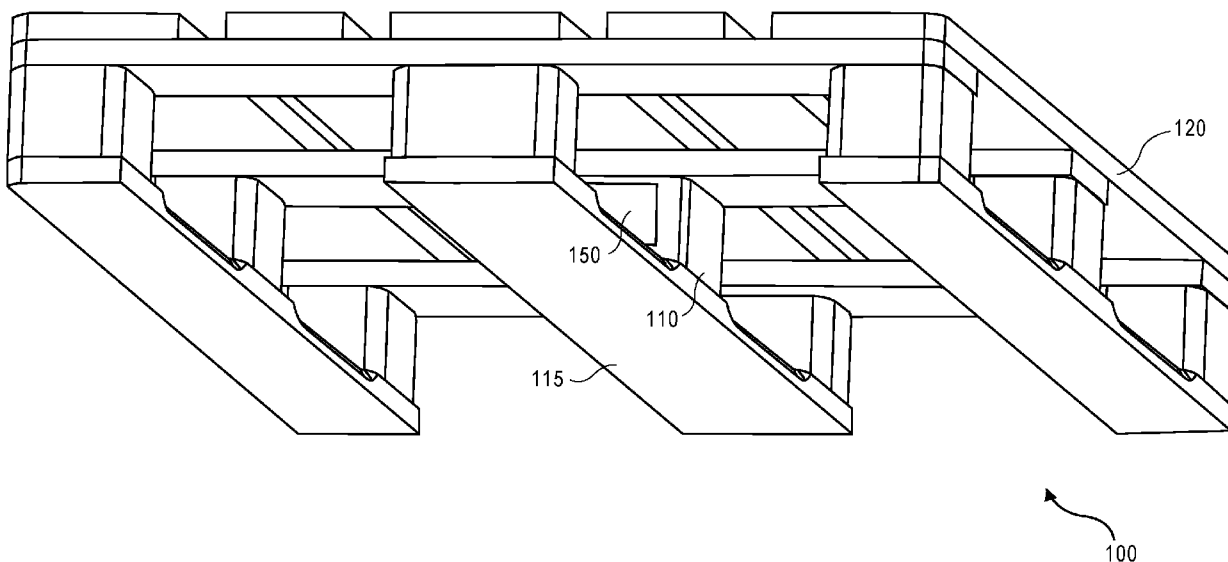

FIG. 1

(57) Abstract: Provided are methods, including computer-implemented methods, devices, and computer-program products applying systems and methods for facility matching and localization. According to some embodiments of the invention, the location of a pallet at a facility within a supply chain may be determined from location data received from a beacon on the pallet. In some embodiments, the position of the pallet within the facility may also be determined. Thus, the status of pallets may be monitored as they move through the supply chain.



GM, KE, LR, LS, MW, MZ, NA, RW, SD, SL, ST, SZ, TZ,
UG, ZM, ZW), Eurasian (AM, AZ, BY, KG, KZ, RU, TJ,
TM), European (AL, AT, BE, BG, CH, CY, CZ, DE, DK,
EE, ES, FI, FR, GB, GR, HR, HU, IE, IS, IT, LT, LU, LV,
MC, MK, MT, NL, NO, PL, PT, RO, RS, SE, SI, SK, SM,
TR), OAPI (BF, BJ, CF, CG, CI, CM, GA, GN, GQ, GW,
KM, ML, MR, NE, SN, TD, TG).

Published:

— *with international search report (Art. 21(3))*

SYSTEMS AND METHODS FOR FACILITY MATCHING AND LOCALIZATION

CROSS-REFERENCES TO RELATED APPLICATIONS

[0001] This application claims the benefit of U.S. Provisional Patent Application No. 62/500,461, filed May 2, 2017, the contents of which are hereby incorporated by reference in their entirety.

FIELD

[0002] The present disclosure generally relates to cargo transportation utilizing pallets, and more specifically to systems and methods for matching pallets to facilities and localizing pallets.

BACKGROUND

[0003] Monitoring pallet movement through a supply and distribution chain can aid in diagnosing issues with pallet loss and recovery, pallet damage and pallet cycle time. Reducing loss, damage and cycle time may have a material benefit for entities across the supply chain. Tracking pallets through the supply chain may also facilitate tracking of the assets they carry whenever an association between the two may be captured. A key requirement for tracking and tracing pallets through the supply chain is the ability to accurately assign a device attached to a pallet, such as an active tag including a BLE, WiFi, RFID, and/or cellular device that may also have GPS capabilities, to the correct known facility. Given the sometimes harsh constraints of the operating environment where pallets are primarily indoors, a technology such as GPS alone may be unreliable. Under certain conditions, satellite-based GPS may not work and no latitude and longitude information may be available. Even when satellite-based GPS provides accurate latitude and longitude, the latitude and longitude may not be resolved or mapped to the specific address of a facility that participates in the supply chain, rendering the latitude and longitude unusable. Without this mapping, actionable metrics about movement of assets in the supply chain may not be feasible.

BRIEF SUMMARY

[0004] Provided are methods, including computer-implemented methods, devices, and computer-program products applying systems and methods for facility matching and localization. According to some embodiments of the invention, the location of a pallet at a facility within a supply chain may be determined from location data received from a device (e.g., a beacon) on the pallet. As used herein, “location data” may include any data indicative of the location of the pallet, including, but not limited to, geographic data, pressure data, light sensor data, temperature data, humidity data, movement data, environmental condition data, etc. According to some embodiments, the methods, devices, and computer-program products described herein may intelligently generate, mark, or prioritize data based on heuristics that incorporate business context, such as average speed of movement of a forklift in a service center, so as to aid machine learning algorithms that drive facility mapping. In some embodiments, the position of the pallet within the facility may also be determined. Thus, the status of pallets may be monitored as they move through the supply chain.

[0005] According to some embodiments of the invention, a computer-implemented method is provided. The method comprises receiving, at a server computer located in a cloud, location data and a device identifier from a device affixed to a pallet. The location data was generated by hardware associated with the device. The location data may include geographic data, but may alternatively or additionally include any data indicative of the location of the pallet. The pallet is located at a facility of a plurality of facilities in a supply chain. The method further comprises accessing a database storing a plurality of sets of attributes indicative of a plurality of locations of the plurality of facilities in the supply chain. The method further comprises comparing the location data to the plurality of sets of attributes to identify a matching set of attributes associated with the facility of the plurality of facilities. The location data may match the set of attributes. The method further comprises outputting an identifier of the facility.

[0006] According to some embodiments of the invention, a device is provided. The device comprises one or more processors. The device further comprises a non-transitory computer-readable medium containing instructions that, when executed by the one or more processors, cause the one or more processors to perform operations including the steps of the methods described herein.

[0007] According to some embodiments of the invention, a computer-program product is provided. The computer-program product is tangibly embodied in a non-transitory machine-readable storage medium of a device. The computer-program product includes instructions that, when executed by one or more processors, cause the one or more processors to perform operations including the steps of the methods described herein.

[0008] This summary is not intended to identify key or essential features of the claimed subject matter, nor is it intended to be used in isolation to determine the scope of the claimed subject matter. The subject matter should be understood by reference to appropriate portions of the entire specification of this patent, any or all drawings, and each claim.

[0009] The foregoing, together with other features and embodiments, will become more apparent upon referring to the following specification, claims, and accompanying drawings.

BRIEF DESCRIPTION OF THE DRAWINGS

[0010] Illustrative embodiments of the present invention are described in detail below with reference to the following drawing figures:

[0011] FIG. 1 is a bottom perspective view of a pallet with a beacon, in accordance with some embodiments.

[0012] FIG. 2 is a side view of a pallet with a load, in accordance with some embodiments.

[0013] FIG. 3 is a block diagram illustrating a pallet, in accordance with some embodiments.

[0014] FIG. 4 is a block diagram illustrating a system for facility matching and localization, in accordance with some embodiments.

[0015] FIG. 5 is a block diagram illustrating an access device, in accordance with some embodiments.

[0016] FIG. 6 is a block diagram illustrating a server computer, in accordance with some embodiments.

[0017] FIG. 7 is a flow chart illustrating a method for facility matching and localization, in accordance with some embodiments.

DETAILED DESCRIPTION

[0018] Certain aspects and embodiments of this disclosure are provided below. Some of these aspects and embodiments may be applied independently and some of them may be applied in combination as would be apparent to those of skill in the art. In the following description, for the purposes of explanation, specific details are set forth in order to provide a thorough understanding of embodiments of the invention. However, it will be apparent that various embodiments may be practiced without these specific details. The figures and description are not intended to be restrictive.

[0019] The ensuing description provides exemplary embodiments only, and is not intended to limit the scope, applicability, or configuration of the disclosure. Rather, the ensuing description of the exemplary embodiments will provide those skilled in the art with an enabling description for implementing an exemplary embodiment. It should be understood that various changes may be made in the function and arrangement of elements without departing from the spirit and scope of the invention as set forth in the appended claims.

[0020] Specific details are given in the following description to provide a thorough understanding of the embodiments. However, it will be understood by one of ordinary skill in the art that the embodiments may be practiced without these specific details. For example, circuits, systems, networks, processes, and other components may be shown as components in block diagram form in order not to obscure the embodiments in unnecessary detail. In other instances, well-known circuits, processes, algorithms, structures, and techniques may be shown without unnecessary detail in order to avoid obscuring the embodiments.

[0021] Also, it is noted that individual embodiments may be described as a process which is depicted as a flowchart, a flow diagram, a data flow diagram, a structure diagram, or a block diagram. Although a flowchart may describe the operations as a sequential process, many of the operations can be performed in parallel or concurrently. In addition, the order of the operations may be re-arranged. A process is terminated when its operations are completed, but could have additional steps not included in a figure. A process may correspond to a method, a function, a procedure, a subroutine, a subprogram, etc. When a process corresponds to a function, its termination can correspond to a return of the function to the calling function or the main function.

[0022] The term “computer-readable medium” includes, but is not limited to, portable or non-portable storage devices, optical storage devices, and various other mediums capable of storing, containing, or carrying instruction(s) and/or data. A computer-readable medium may include a non-transitory medium in which data can be stored and that does not include carrier waves and/or transitory electronic signals propagating wirelessly or over wired connections. Examples of a non-transitory medium may include, but are not limited to, a magnetic disk or tape, optical storage media such as compact disk (CD) or digital versatile disk (DVD), flash memory, memory or memory devices. A computer-readable medium may have stored thereon code and/or machine-executable instructions that may represent a procedure, a function, a subprogram, a program, a routine, a subroutine, a module, a software package, a class, or any combination of instructions, data structures, or program statements. A code segment may be coupled to another code segment or a hardware circuit by passing and/or receiving information, data, arguments, parameters, or memory contents. Information, arguments, parameters, data, etc. may be passed, forwarded, or transmitted via any suitable means including memory sharing, message passing, token passing, network transmission, or the like.

[0023] Furthermore, embodiments may be implemented by hardware, software, firmware, middleware, microcode, hardware description languages, or any combination thereof. When implemented in software, firmware, middleware or microcode, the program code or code segments to perform the necessary tasks (e.g., a computer-program product) may be stored in a computer-readable or machine-readable medium. A processor(s) may perform the necessary tasks.

Pallets

[0024] A pallet may be a structure that supports physical assets for storage, presentation, handling, and/or transportation. As used herein, the term “pallet” may be used to describe any load carrier, including any type of platform, dolly, bin, container, and the like. The physical assets may be any physical assets, such as perishable or nonperishable physical goods. FIG. 1 is a bottom perspective view of a pallet 100, in accordance with some embodiments. The pallet 100 may include a base 120 and legs 110. The pallet 100 may be of any size, shape, and/or dimension, and may be made of any material or combination of materials. The base 120 and legs 110 may be of any size, shape, and/or dimensions. The base 120 may be flat and/or otherwise

configured to support the shape and/or weight of the physical asset to be held on the pallet 100. Although shown as having a particular design in FIG. 1, it is contemplated that any design may be incorporated on or in the base 120. For example, the base 120 may have smaller, larger, fewer, more, differently shaped, or differently placed spacing than those shown in FIG. 1, depending on characteristics of the particular physical asset to be placed on the base 120 (e.g., weight, shape, temperature requirements, size, etc.).

[0025] The legs 110 may be sized and positioned to support the particular physical asset. In some embodiments, the legs 110 may be sized and positioned to allow a forklift, crane, or jacking device to engage and lift the pallet 100 between the legs 110. Although shown and described as having three legs 110, it is contemplated that the pallet 100 may have any suitable number of legs or no legs. For example, in some embodiments, the pallet 100 may include a base 120 on both the top and bottom of the pallet 100 with no legs. In another example, for heavier physical assets, the pallet 100 may include one or more additional legs centrally located with respect to the pallet 100 to prevent sagging of the base 120. Further, although shown and described as being in a particular orientation and having a particular size, it is contemplated that the legs 110 may be of any size (e.g., height, length, width, depth, etc.) and/or orientation (e.g., parallel to each other, perpendicular to each other, etc.).

[0026] The pallet 100 may be made of any suitable material, depending on the characteristics of the particular physical asset to be supported by the pallet 100. For example, the pallet 100 may be wooden, plastic, and/or metal. In some embodiments, the pallet 100 may be constructed to include unique physical features. In some embodiments, the base 120 may be made of a same or different material than the legs 110. In some embodiments, the base 120 and the legs 110 may form a single unitary body (e.g., formed from a single mold). In some embodiments, the base 120 may be removable from one or more of the legs 110.

[0027] In some embodiments, additional components may be integrated with the pallet 100. For example, the underside of the pallet 100 may include a beacon 150. The beacon 150 may include a number of different functionalities. For example, the beacon 150 may be programmed with the type of physical asset located on the pallet 100 and/or an identifier of the pallet 100. The beacon 150 may further include or be in operable communication with one or more sensors configured to monitor certain conditions of the pallet 100 (e.g., environmental conditions,

movements, etc.). The beacon 150 is described further herein with respect to FIG. 3. Although shown as being located in a particular position on the pallet 100, it is contemplated that the beacon 150 may be located in any suitable position on the pallet 100. FIG. 2 is a side view of another exemplary pallet 200 with a load 220 placed atop the pallet 200 for transportation, storage, presentation, etc. As used herein, pallet 100 may be referred to interchangeably with pallet 200.

[0028] The pallet 100 and/or 200 may include components for performing multiple functions, as described herein. FIG. 3 is a block diagram illustrating the system components of the pallet 100 and/or 200, in accordance with some embodiments. The pallet 100 and/or 200 may include a beacon 115 in operative communication with one or more external sensors 350. The beacon 115 may include device hardware coupled to a memory 340. The device hardware may include a processor 325, a communication subsystem 330, internal sensors 335, and a power supply 345. In some embodiments, the beacon 115 may be implemented as an active tag (e.g., an RFID tag). The beacon 115 may be associated with an identifier (e.g., an active tag identifier).

[0029] The processor 325 may be implemented as one or more integrated circuits (e.g., one or more single core or multicore microprocessors and/or microcontrollers), and may be used to control the operation of the beacon 115. The processor 325 can execute a variety of programs in response to program code or computer-readable code stored in memory 340, and can maintain multiple concurrently executing programs or processes. The communication subsystem 330 may include one or more transceivers and/or connectors that can be used by the beacon 115 to communicate with other devices (e.g., the external sensors 350, access devices, etc.) and/or to connect with external networks. In some embodiments, the communication subsystem 330 may be configured to communicate using more than one protocol (e.g., protocol A 332 and protocol B 333). Protocol A 332 and protocol B 333 may be two different wired or wireless communication protocols. For example, protocol A 332 and protocol B 333 may be selected from the group including Bluetooth, Bluetooth LE, near field communication (including IoT), WiFi, cellular communication, Ethernet, fiber optics, etc. The particular protocol used for a particular communication may be determined based on any of a number of factors, including availability, signal strength, type and/or amount of power received from or remaining on power supply 345, data throughput, type of data to be communicated, size of data to be communicated, and the like.

[0030] The internal sensors 335 may include any movement-related, location-related, and/or environmental-related sensors. For example, the internal sensors 335 may include a global positioning system (GPS), an accelerometer, a gyroscope, a barometer, a thermometer, a humidity sensor, a light sensor, a microphone, combinations thereof, and/or the like. The internal sensors 335 may be coupled to the communication subsystem 330, such that sensor measurements may be transmitted off of the pallet 100 to other devices or systems, as described further herein.

[0031] The memory 340 may be implemented using any combination of any number of non-volatile memories (e.g., flash memory) and volatile memories (e.g., DRAM, SRAM), or any other non-transitory storage medium, or a combination thereof media. In some embodiments, the memory 340 may be included in the processor 325. The power supply 345 may include any wired or wireless power supply, such as a power outlet supply, a solar panel, and/or a battery.

[0032] The beacon 115 may be coupled to one or more external sensors 350 on the pallet 100 in some embodiments. The external sensors 350 may include, for example, a weight sensor and/or any of the sensors described above with respect to the internal sensors 335. In one example, the weight sensor may include circuitry that measures the weight of a load on the pallet 100. The weight sensor may transmit the weight to the beacon 115. The beacon may use the communication subsystem 330 to transmit this data off of the pallet 100 to other devices or systems, as described further herein.

Systems for Facility Matching and Localization

[0033] In some cases, it may be desirable to identify a pallet's location in the supply chain. According to some embodiments of the invention, the location of a pallet anywhere in the supply chain may be determined. Conventional tracking solutions that provide accurate location traceability rely on installed infrastructure, such as proximity sensors and fixed manual or automated processes. In other words, the instrumentation is aimed at digitizing specific events, and the location of the digitizing device provides the location of the pallet. According to some embodiments of the invention, however, fixed infrastructure and minimum human compliance are needed to determine the pallet's location. For example, according to some embodiments, data may be captured that in turn determines the pallet's location based on the installation location of the data capturing device. Once the pallet's location has been identified, this

information may be used to compute supply chain visibility metrics, such as inventory at any given location or region, dwell time, and velocity metrics between regions of the supply chain or between any set of nodes within the supply chain.

[0034] FIG. 4 is a block diagram illustrating a system for facility matching and localization, in accordance with some embodiments. The system may include a pallet 100, an access device 410, a server computer 420, a database 425, and a controller computer 430. The pallet 100 and the access device 410 may be located at a facility 405 in the supply chain, such as a warehouse or store. The server computer 420 and the database 425 may be located in the cloud, such as at one or more offsite or third party locations with online or networked storage. The controller computer 430 may be located at a controller location 425, such as at a pallet logistics and tracking company. Although shown and described with respect to a certain number of entities performing certain functions, it is contemplated that a greater or fewer number of entities may perform the functions described herein. For example, the functions of the server computer 420 may be spread across multiple server computers. In another example, the database 425 may be incorporated internally to the server computer 420.

[0035] In some embodiments, the pallet 100 may communicate data to the access device 410 via a beacon or other communication medium. The data may cause the access device 410 to perform one or more operations. For example, the pallet 100 may communicate (or cause to be communicated) data indicative of its location (e.g., GPS coordinates, a latitude and longitude, triangulated coordinates, etc.). The pallet 100 may alternatively or additionally communicate an identifier that uniquely identifies the pallet 100 and/or the beacon. The data may be communicated, for example, by a Bluetooth, Bluetooth LE, WiFi, or cellular tag on the pallet 100. When the access device 410 receives the signal, the access device 410 may process the data and forward it to the server computer 420. In some embodiments, the access device 410 may only communicate with the pallet 100 if the pallet 100 is a recognized or registered pallet. A pallet 100 may be recognized or registered based on, for example, a pallet identifier. In some embodiments, the pallet 100 may communicate a ping to the access device 410 that causes the access device 410 to capture an image of the pallet 100. The image of the pallet 100 may then be used to correlate the pallet 100 to the location where it is positioned.

[0036] The access device 410 may be any suitable electronic user device. The access device 410 may include a communication device. A communication device may provide remote communication capabilities to a network. Examples of remote communication capabilities include using a mobile phone (wireless) network, wireless data network (e.g., 3G, 4G or similar networks), Wi-Fi, Wi-Max, or any other communication medium that may provide access to a network such as the Internet or a private network. Examples of devices include beacons, mobile phones (e.g., cellular phones), PDAs, tablet computers, net books, laptop computers, personal music players, handheld specialized readers, watches, fitness bands, wearables, ankle bracelets, rings, earrings, key fobs, physical wallets, glasses, containers, coffee mugs, takeout containers, etc., as well as automobiles with remote communication capabilities. The access device 410 may comprise any suitable hardware and software for performing such functions, and may also include multiple devices or components (e.g., when a device has remote access to a network by tethering to another device – i.e., using the other device as a modem – both devices taken together may be considered a single communication device). Further examples of an access device 410 may include a POS or point of sale device (e.g., POS terminals), cellular phone, PDA, personal computer (PCs), tablet PC, hand-held specialized reader, set-top box, electronic cash register (ECR), virtual cash registers (VCR), kiosk, and the like. In some embodiments, the access device 410 may be included in a pallet

[0037] The access device 410 may have an application installed that allows it to detect the pallet 100, identify the pallet 100, and upload location data from the pallet 100 to a server computer 420. The access device 410 may be in communication with the server computer 420. The access device 410 may forward the location data and the identifier of the pallet 100 to the server computer 420. The server computer 420 may access a database 425 storing sets of attributes indicative of locations of facilities in the supply chain. For example, each facility in the supply chain may have an entry in the database 425 with a facility identifier (e.g., a name), a physical address (e.g., a street address), and a set of attributes (e.g., a latitude and longitude associated with the physical address, an ambient temperature, a wall color, a light level, a humidity level, etc.). The server computer 420 may compare the location data received from the pallet 100 to the sets of attributes to identify a matching set of attributes associated with the facility in which the pallet 100 is located. In the case of location coordinates, the location data

may be within a threshold distance of the matching set of attributes (e.g., the GPS coordinates are within 0.1 miles of the facility's latitude and longitude).

[0038] The server computer 420 may store the identifier of the pallet 100 in association with the matched facility in the database 425. For example, the server computer 420 may retrieve the entry in the database 425 associated with the matched facility and write the identifier of the pallet 100 in the record. In some embodiments, the identifier of the pallet 100 may be written to the record along with a timestamp indicating the date and time that the pallet 100 transmitted the location data that was ultimately matched to the facility. Thus, the record corresponding to a particular facility may include a plurality of identifiers of a plurality of pallets that were present at the facility at a plurality of times. In some embodiments, some or all of the functions of the server computer 420 may alternatively or additionally be performed by another entity or system, such as the access device 410.

[0039] In some embodiments, the server computer 420 may provide these records from the database 425 to a controller computer 430. The controller computer 430 may be an entity that tracks, maintains, and/or owns the pallet 100. The controller computer 430 may use this data to determine whether the pallet 100 is at the correct facility 405, to determine where the pallet 100 is in the supply chain, to determine the cycle time of the pallet 100, to predict timing of the pallet 100 at a particular location, to compute supply chain visibility metrics, etc. In some embodiments, supply chain visibility metrics may include inventory at a given facility or in a given region, dwell time, and velocity metrics between regions or between facilities in the supply chain.

[0040] FIG. 5 is a block diagram illustrating an access device 410, in accordance with some embodiments. The access device 410 may include device hardware 504 coupled to a memory 502. Device hardware 504 may include a processor 505, a communication subsystem 509, and a user interface 506. In some embodiments, device hardware 504 may include a display 507 (which can be part of the user interface 506).

[0041] Processor 505 can be implemented as one or more integrated circuits (e.g., one or more single core or multicore microprocessors and/or microcontrollers), and is used to control the operation of the access device 410. Processor 505 can execute a variety of programs in response to program code or computer-readable code stored in memory 502, and can maintain multiple

concurrently executing programs or processes. Communication subsystem 509 may include one or more transceivers and/or connectors that can be used by access device 410 to communicate with other devices (e.g., the pallet 100) and/or to connect with external networks (e.g., to connect to the server computer 420). User interface 506 can include any combination of input and output elements to allow a user to interact with and invoke the functionalities of the access device 410. In some embodiments, user interface 506 may include a component such as display 507 that can be used for both input and output functions. Memory 502 can be implemented using any combination of any number of non-volatile memories (e.g., flash memory) and volatile memories (e.g., DRAM, SRAM), or any other non-transitory storage medium, or a combination thereof. Memory 502 may store an operating system (OS) 520 and an application environment 510 where one or more applications reside including application 512 to be executed by processor 505.

[0042] In some embodiments, application 512 may be an application that detects and identifies pallets, and/or transmits data received from a pallet to a server computer via a communication medium that may not be available to the pallet (e.g., cellular communications). Application 512 may include a pallet detection engine 514 and a pallet identification engine 515. In some embodiments, one or more of these components can be provided by another application or component that is not part of application 512.

[0043] The pallet detection engine 514 may be configured to, in conjunction with the processor 505 and the communication subsystem 509, receive a ping (i.e., a brief signal) from a pallet in proximity to the access device 410. In some embodiments, the pallet may be configured to send a ping to the communication subsystem 509 when within a certain distance of the access device 410 (e.g., 10 feet). In some embodiments, the pallet may be configured to send a ping to the communication subsystem 509 when within any communication range of the access device 410 (e.g., 50 feet), and the pallet detection engine 514 may monitor the distance between the access device 410 and the pallet based on the pings. In some embodiments, when the ping is received by the pallet detection engine 514, the pallet detection engine 514 may transmit a request for location data to the pallet. In some embodiments, when the ping is received by the pallet detection engine 514, the pallet detection engine 514 sends a response ping indicating that the access device 410 is within communication range of the pallet. The response ping may cause the

pallet to push the location data to the access device 410. As used herein, “location data” may include any data indicative of the location of the pallet, including, but not limited to, geographic data, pressure data, light sensor data, temperature data, humidity data, movement data, environmental condition data, etc. Location data may be obtained using triangulation, as described further herein. In some embodiments, location data may be obtained using magnetometer data. In some embodiments, location data may be obtained from another device or pallet that has improved awareness of its location. For example, a first pallet may have a GPS fix and may assign a high confidence at being at a certain location, while a second pallet is deeper in the facility and does not have GPS access, WiFi access, or an uncertain cellular fix. If the first pallet detects a BLE signal from the second pallet, the location assignment and confidence may be transferred from the first pallet to the second pallet.

[0044] The pallet identification engine 515 may be configured to, in conjunction with the processor 505, receive an identifier from a pallet with its location data. The pallet identification engine 515 may extract the identifier from the other data. In some embodiments, the pallet identification engine 515 may translate the identifier from a first format used by the pallet (i.e., a format stored on the beacon) into a second format used by external systems (e.g., the server computer, the controller computer, etc.). The pallet identification engine 515 may perform this translation by accessing a lookup table with entries corresponding to the received identifier and corresponding identifiers used by external systems.

[0045] FIG. 6 is a block diagram illustrating a server computer 420, in accordance with some embodiments. Server computer 420 may include a processor 601 coupled to a network interface 602 and a computer readable medium 606. Server computer 420 may also include or otherwise have access to a database 603 that may be internal or external to the server computer 420.

[0046] Processor 601 may include one or more microprocessors to execute program components for performing the facility matching and localization functions of the server computer 420. Network interface 602 may be configured to connect to one or more communication networks to allow the server computer 420 to communicate with other entities, such as the access device, the controller computer, etc. Computer readable medium 606 may include any combination of one or more volatile and/or non-volatile memories, for example, RAM, DRAM, SRAM, ROM, flash, or any other suitable memory components. Computer

readable medium 606 may store code executable by the processor 601 for implementing some or all of the facility matching and localization functions of server computer 420. For example, computer readable medium 606 may include code implementing a facility location retrieval engine 608, a location comparison engine 609, a pallet location update engine 610, a pallet position determination engine 611, and a pallet position update engine 612.

[0047] The facility location retrieval engine 608 may be configured to, in conjunction with the processor 601, access the database 603 to retrieve sets of attributes, including any data indicative of locations of facilities in the supply chain (e.g., coordinates, environmental conditions, visual features, etc.). In some embodiments, the facility location retrieval engine 608 may be configured to retrieve only sets of attributes corresponding to facilities that meet certain criteria. The criteria may include facilities within a certain region (e.g., an expected region of the pallet), type of facility (e.g., shipper facility, carrier facility, storefront, etc.), etc. This may reduce the number of facility locations to which the location data from the pallet needs to be compared, which may reduce processing time.

[0048] The location comparison engine 609 may be configured to, in conjunction with the processor 601, receive location data from a pallet (e.g., via an access device) and the retrieved facility locations from the facility location retrieval engine 608. The location comparison engine 609 may be configured to compare the location data to the sets of attributes of facilities to identify a matching facility location. In some embodiments, the location comparison engine 609 may convert disparate formats between the location data and the facility locations into the same format to facilitate accurate comparison. For example, if the location data includes GPS coordinates and the facility locations include physical addresses, the location comparison engine 609 may convert the physical addresses into GPS coordinates before comparing them. The matching facility location may be identified based on its location within a threshold distance of the location data. For example, the distance between the location data and the matching facility location may be less than a 0.15 mile threshold.

[0049] In some embodiments, the location comparison engine 609 may be configured to identify multiple potential matching facilities (e.g., all facilities within 0.1 miles of the location data) and provide a distance metric between the matching facilities and the location data, e.g., 0.05 miles from the location data, 0.07 miles from the location data, etc. The multiple potential

matching facilities may be ranked from the closest to the location data to the furthest from the location data in some embodiments. The multiple potential matching facilities may further be ranked based on certain criteria, such as the expected location or facility of the pallet within the supply chain at the time the location data was transmitted. For example, some factors that may make one facility more likely than another may include matching transaction data, a more likely facility type (such as a service center being likely to ship to a manufacturer), a model of the supply chain (e.g., one manufacturing facility may be most likely to ship to a certain store), and/or the like. In some embodiments, the highest ranked facility of the multiple potential matching facilities may be selected as the matching facility. In some embodiments, the location comparison engine 609 may provide a degree of confidence for the matching facility. In some embodiments, there may be no potential facility matches based on criteria.

[0050] In some embodiments, the location comparison engine 609 may compare other data indicative of the location of the pallet to data associated with a facility to select and/or rank facilities. For example, in some embodiments, the location data received from the pallet may include environmental condition data, such as temperature data, movement data (e.g., forklift speeds versus conveyor belt speeds), moisture data and humidity data (e.g., in a washing machine), etc. The location comparison engine 609 may translate this data into attributes associated with a facility in order to match the pallet to a known facility.

[0051] The pallet location update engine 610 may be configured to, in conjunction with the processor 601, store the identifier of the pallet in association with the matching facility. For example, the pallet location update engine 610 may retrieve the entry in the database 603 associated with the matched facility (e.g., using a facility identifier, such as a name or a unique code) and write the identifier of the pallet in the record. In some embodiments, the identifier of the pallet may be written to the record along with a timestamp indicating the date and time that the pallet transmitted the location data that was ultimately matched to the facility. Thus, the record corresponding to a particular facility may include a plurality of identifiers of a plurality of pallets that were present at the facility at a plurality of times. This record may be used to analyze a particular facility's status and/or load in the supply chain.

[0052] Conversely, the pallet location update engine 610 may alternatively or additionally be configured to, in conjunction with the processor 601, retrieve the entry in the database 603

associated with the identifier of the pallet and write the matched facility in the record. In some embodiments, the matched facility may be written to the record along with a timestamp indicating the date and time that the pallet transmitted the location data that was ultimately matched to the facility. Thus, the record corresponding to a particular pallet may include a plurality of facilities at which the pallet was present at a plurality of times. This record may be used to analyze a particular pallet's movement through the supply chain.

[0053] In some embodiments in which other location data (e.g., humidity data, temperature data, etc.) are provided by the pallet and specific attributes associated with a facility are previously unknown, the pallet location update engine 610 may create attributes in the record associated with the matching facility corresponding to the other location data provided by the pallet. In some embodiments, the pallet location update engine 610 may be self-learning and/or healing in that it may auto-learn attributes associated with a known location, auto-create known locations with well-known attributes while allowing administrators to review and update information, and/or auto-learn addresses based on third party services that can provide physical addresses and business and/or category information for a given set of facility data.

[0054] The pallet position determination engine 611 may be configured to, in conjunction with the processor 601, receive the location data from the pallet (e.g., via an access device), along with the matching facility from the location comparison engine 609. The pallet position determination engine 611 may be configured to retrieve from the database 603 a file including a floor plan of the matching facility. The pallet position determination engine 611 may be configured to map the location data from the pallet onto the floor plan of the facility to identify a position of the pallet within the facility (e.g., in a storage area, in a transportation area, at the loading dock, etc.). For example, the pallet position determination engine 611 may map a latitude and longitude of the pallet onto a visual representation of a floor plan of a facility to determine to which part of the floor plan the latitude and longitude correspond.

[0055] The pallet position update engine 612 may be configured to, in conjunction with the processor 601, receive data indicative of the position of the pallet within the facility from the pallet position determination engine 611. In some embodiments, the pallet position update engine 612 may be configured to store the position of the pallet along with its identifier in association with the matching facility in the database 603. In some embodiments, the pallet

position update engine 612 may be configured to retrieve the entry in the database 603 associated with the identifier of the pallet and write the position of the pallet along with the matched facility in the record.

Methods for Facility Matching and Localization

[0056] A variety of methods may be implemented by the above-described systems. FIG. 7 is a flow chart illustrating an exemplary method for facility matching and localization, in accordance with some embodiments. At process block 410, location data 705 and a device identifier 707 are received at a server computer. The location data 705 may be received from a device (e.g., a beacon) affixed to a pallet. The location data was generated by hardware (e.g., a GPS) associated with the device. In some embodiments, the hardware may be located in a mobile device (e.g., a mobile phone). In some embodiments, the location data may include data generated using at least one WiFi router. For example, the location data may be generated by pinging three or more WiFi routers and triangulating the location of the device based on the signal strength. In some embodiments, the location data may include data generated using at least one cellular tower. For example, the location data may be generated by receiving data from three or more cellular towers and triangulating the location of the device based on the signal strength. In some embodiments, the device may not receive data from, or evoke a response from, the WiFi routers or the cellular towers. Instead, the triangulation may be based on the number of “sighted” WiFi routers and cellular towers and their relative signal strengths. In some embodiments, the location data may be generated using Bluetooth. In some embodiments, the location data may include a MAC ID. The pallet may be located at a facility of a plurality of facilities in a supply chain. Further at process block 410, a database is accessed. The database may store one or more sets of attributes corresponding to locations of the plurality of facilities in the supply chain.

[0057] At process block 713, the location data 705 is matched to the sets of attributes to identify a matching set of attributes associated with the facility in which the pallet is located. Further at process block 715, if the location data 705 includes geographic data and the set of attributes includes geographic data, a threshold distance may be received, and the location data is determined to be within the threshold distance of the set of attributes. At process block 720, the facility identifier 707 may be output. In some embodiments, the location data 705 and/or the

device identifier 707 may further be stored in association with the facility identifier in the database.

[0058] In some embodiments in which the location data 705 includes geographic data, a file including a floor plan of the matching facility may further be retrieved from the database. The geographic data may be mapped onto the floor plan of the facility to identify a position of the device within the facility. Data indicative of the position of the device may be stored in the database.

[0059] As noted, the computer-readable medium may include transient media, such as a wireless broadcast or wired network transmission, or storage media (that is, non-transitory storage media), such as a hard disk, flash drive, compact disc, digital video disc, Blu-ray disc, or other computer-readable media. The computer-readable medium may be understood to include one or more computer-readable media of various forms, in various examples.

[0060] In the foregoing description, aspects of the application are described with reference to specific embodiments thereof, but those skilled in the art will recognize that the invention is not limited thereto. Thus, while illustrative embodiments of the application have been described in detail herein, it is to be understood that the inventive concepts may be otherwise variously embodied and employed, and that the appended claims are intended to be construed to include such variations, except as limited by the prior art. Various features and aspects of the above-described invention may be used individually or jointly. Further, embodiments can be utilized in any number of environments and applications beyond those described herein without departing from the broader spirit and scope of the specification. The specification and drawings are, accordingly, to be regarded as illustrative rather than restrictive. For the purposes of illustration, methods were described in a particular order. It should be appreciated that in alternate embodiments, the methods may be performed in a different order than that described.

[0061] Where components are described as performing or being “configured to” perform certain operations, such configuration can be accomplished, for example, by designing electronic circuits or other hardware to perform the operation, by programming programmable electronic circuits (e.g., microprocessors, or other suitable electronic circuits) to perform the operation, or any combination thereof.

[0062] The various illustrative logical blocks, modules, circuits, and algorithm steps described in connection with the embodiments disclosed herein may be implemented as electronic hardware, computer software, firmware, or combinations thereof. To clearly illustrate this interchangeability of hardware and software, various illustrative components, blocks, modules, circuits, and steps have been described above generally in terms of their functionality. Whether such functionality is implemented as hardware or software depends upon the particular application and design constraints imposed on the overall system. Skilled artisans may implement the described functionality in varying ways for each particular application, but such implementation decisions should not be interpreted as causing a departure from the scope of the present invention.

[0063] The techniques described herein may also be implemented in electronic hardware, computer software, firmware, or any combination thereof. Such techniques may be implemented in any of a variety of devices such as general purposes computers, wireless communication device handsets, or integrated circuit devices having multiple uses including application in wireless communication device handsets and other devices. Any features described as modules or components may be implemented together in an integrated logic device or separately as discrete but interoperable logic devices. If implemented in software, the techniques may be realized at least in part by a computer-readable data storage medium comprising program code including instructions that, when executed, performs one or more of the methods described above. The computer-readable data storage medium may form part of a computer program product, which may include packaging materials. The computer-readable medium may comprise memory or data storage media, such as random access memory (RAM) such as synchronous dynamic random access memory (SDRAM), read-only memory (ROM), non-volatile random access memory (NVRAM), electrically erasable programmable read-only memory (EEPROM), FLASH memory, magnetic or optical data storage media, and the like. The techniques additionally, or alternatively, may be realized at least in part by a computer-readable communication medium that carries or communicates program code in the form of instructions or data structures and that can be accessed, read, and/or executed by a computer, such as propagated signals or waves.

[0064] The program code may be executed by a processor, which may include one or more processors, such as one or more digital signal processors (DSPs), general purpose microprocessors, an application specific integrated circuits (ASICs), field programmable logic arrays (FPGAs), or other equivalent integrated or discrete logic circuitry. Such a processor may be configured to perform any of the techniques described in this disclosure. A general purpose processor may be a microprocessor; but in the alternative, the processor may be any conventional processor, controller, microcontroller, or state machine. A processor may also be implemented as a combination of computing devices, e.g., a combination of a DSP and a microprocessor, a plurality of microprocessors, one or more microprocessors in conjunction with a DSP core, or any other such configuration. Accordingly, the term “processor,” as used herein may refer to any of the foregoing structure, any combination of the foregoing structure, or any other structure or apparatus suitable for implementation of the techniques described herein. In addition, in some aspects, the functionality described herein may be provided within dedicated software modules or hardware modules configured for encoding and decoding, or incorporated in a combined encoder-decoder (CODEC).

WHAT IS CLAIMED IS:

- 1 1. A computer-implemented method comprising:
2 receiving, at server computer, location data and a device identifier associated with
3 a device affixed to a pallet, wherein the location data was generated by hardware associated with
4 the device, wherein the pallet is located at a facility in a supply chain, and wherein the facility is
5 associated with a set of attributes and a facility identifier;
6 accessing a database storing one or more sets of attributes corresponding to one or
7 more locations of one or more facilities in the supply chain, wherein the database includes the set
8 of attributes associated with the facility;
9 matching the location data to the set of attributes associated with the facility in the
10 database;
11 associating the facility identifier with the device identifier when the location data
12 is matched with the set of attributes; and
13 outputting the facility identifier.
- 1 2. The computer-implemented method of claim 1, wherein the location data
2 includes a set of coordinates, and wherein the method further comprises:
3 retrieving a file including a floor plan of the facility from the database;
4 mapping the set of coordinates onto the floor plan of the facility to identify a
5 position of the device within the facility; and
6 storing data indicative of the position in the database.
- 1 3. The computer-implemented method of claim 1, further comprising:
2 storing the location data in association with the device identifier.
- 1 4. The computer-implemented method of claim 1, wherein the hardware is
2 located in a mobile device.
- 1 5. The computer-implemented method of claim 1, wherein the hardware
2 includes a GPS device.
- 1 6. The computer-implemented method of claim 1, wherein the location data
2 includes data generated using at least one WiFi router.

1 7. The computer-implemented method of claim 1, wherein the location data
2 includes data generated using at least one cellular tower.

1 8. The computer-implemented method of claim 1, wherein the location data
2 includes data generated using Bluetooth.

1 9. A computer-program product tangibly embodied in a non-transitory
2 machine-readable storage medium of a device, including instructions that, when executed by one
3 or more processors, cause the one or more processors to:

4 receive, at the device, location data and a device identifier associated with a
5 device affixed to a pallet, wherein the location data was generated by hardware associated with
6 the device, wherein the pallet is located at a facility in a supply chain, and wherein the facility is
7 associated with a set of attributes and a facility identifier;

8 access a database storing one or more sets of attributes corresponding to one or
9 more locations of one or more facilities in the supply chain, wherein the database includes the set
10 of attributes associated with the facility;

11 match the location data to the set of attributes associated with the facility in the
12 database;

13 associate the facility identifier with the device identifier when the location data is
14 matched with the set of attributes; and

15 output the facility identifier.

1 10. The computer-program product of claim 9, wherein the location data
2 includes a set of coordinates, and wherein the instructions further cause the one or more
3 processors to:

4 retrieve a file including a floor plan of the facility from the database;

5 map the set of coordinates onto the floor plan of the facility to identify a position
6 of the device within the facility; and

7 store data indicative of the position in the database.

1 11. The computer-program product of claim 9, wherein the instructions further
2 cause the one or more processors to:

3 store the location data in association with the device identifier.

1 12. The computer-program product of claim 9, wherein the hardware is
2 located in a mobile device.

1 13. The computer-program product of claim 9, wherein the hardware includes
2 a GPS device.

1 14. The computer-program product of claim 9, wherein the location data
2 includes data generated using at least one WiFi router.

1 15. The computer-program product of claim 9, wherein the location data
2 includes data generated using at least one cellular tower.

1 16. The computer-program product of claim 9, wherein the location data
2 includes data generated using Bluetooth.

1 17. A device comprising:

2 a processor; and

3 a memory coupled to the processor, the memory storing instructions which when
4 executed by the processor, cause the device to perform operations including:

5 receiving, at the device, location data and a device identifier associated
6 with the device affixed to a pallet, wherein the location data was generated by hardware
7 associated with the device, wherein the pallet is located at a facility in a supply chain, and
8 wherein the facility is associated with a set of attributes and a facility identifier;

9 accessing a database storing one or more sets of attributes corresponding
10 to one or more locations of one or more facilities in the supply chain, wherein the database
11 includes the set of attributes associated with the facility;

12 matching the location data to the set of attributes associated with the
13 facility in the database;

14 associating the facility identifier with the device identifier when the
15 location data is matched with the set of attributes; and

16 outputting the facility identifier.

1

1 18. The device of claim 17, wherein the location data includes a set of
2 coordinates, and wherein the operations further include:

3 retrieving a file including a floor plan of the facility from the database;
4 mapping the set of coordinates onto the floor plan of the facility to identify a
5 position of the device within the facility; and
6 storing data indicative of the position in the database.

1 19. The device of claim 17, wherein the operations further include:
2 storing the location data in association with the device identifier.

1 20. The device of claim 17, wherein the hardware is located in a mobile
2 device.

1 21. The device of claim 17, wherein the hardware includes a GPS device.

1 22. The device of claim 17, wherein the location data includes data generated
2 using at least one WiFi router.

1 23. The device of claim 17, wherein the location data includes data generated
2 using at least one cellular tower.

1 24. The device of claim 17, wherein the location data includes data generated
2 using Bluetooth.

1

1

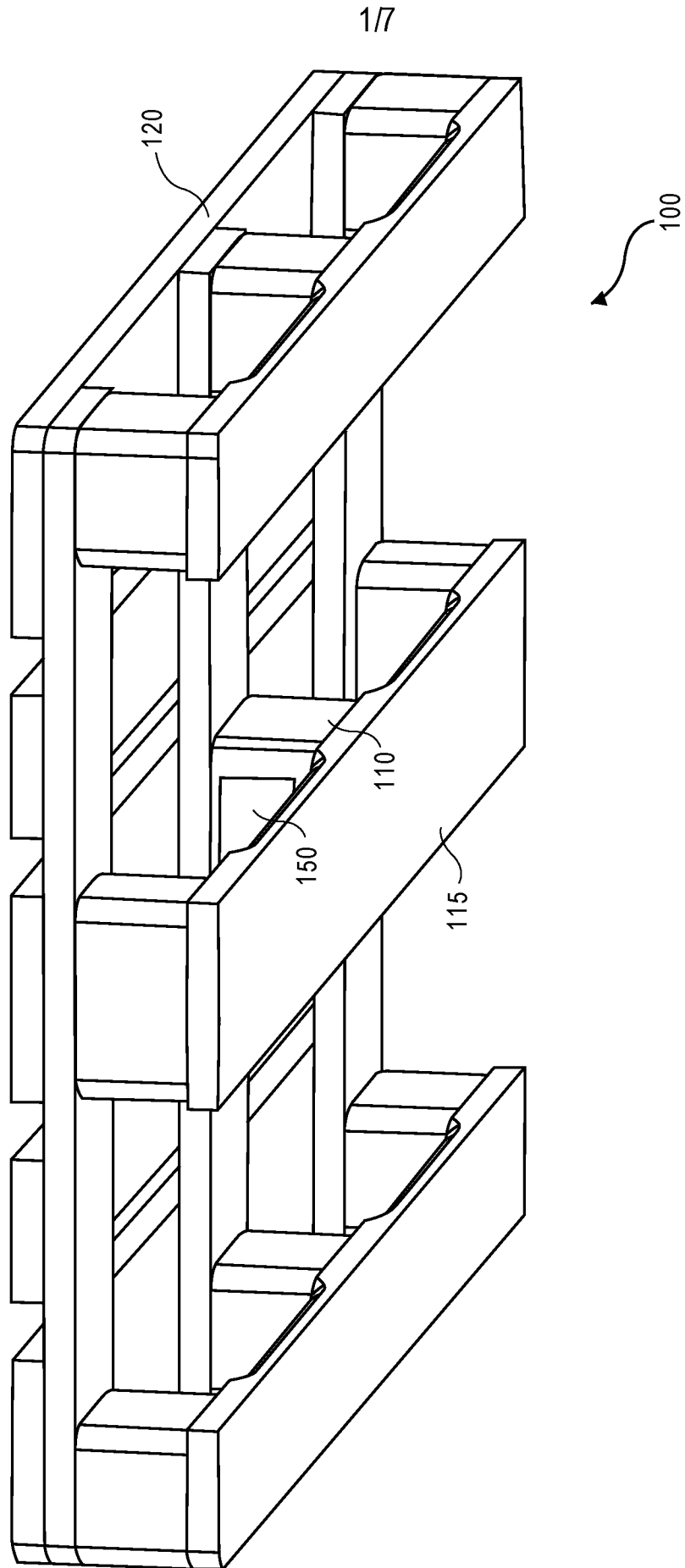

FIG. 1

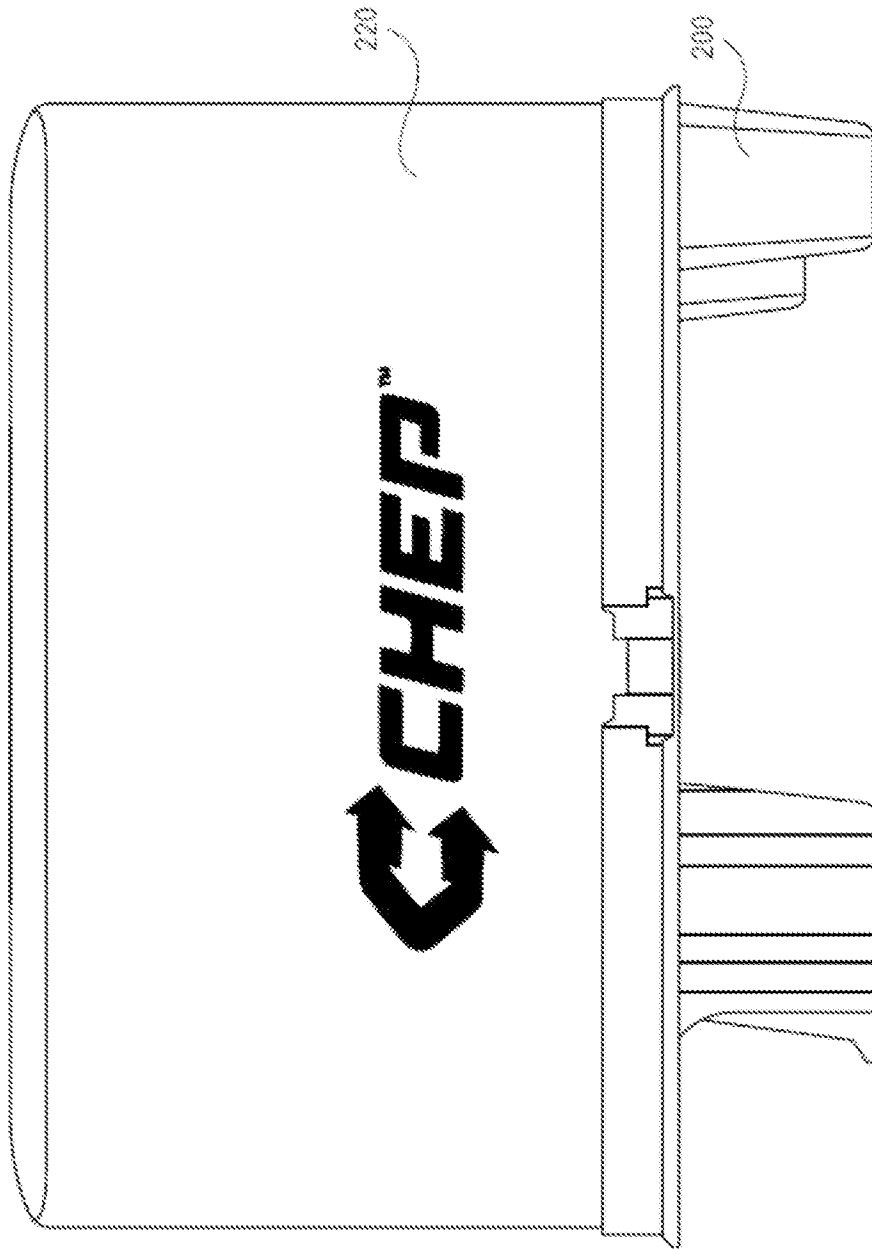

FIG. 2

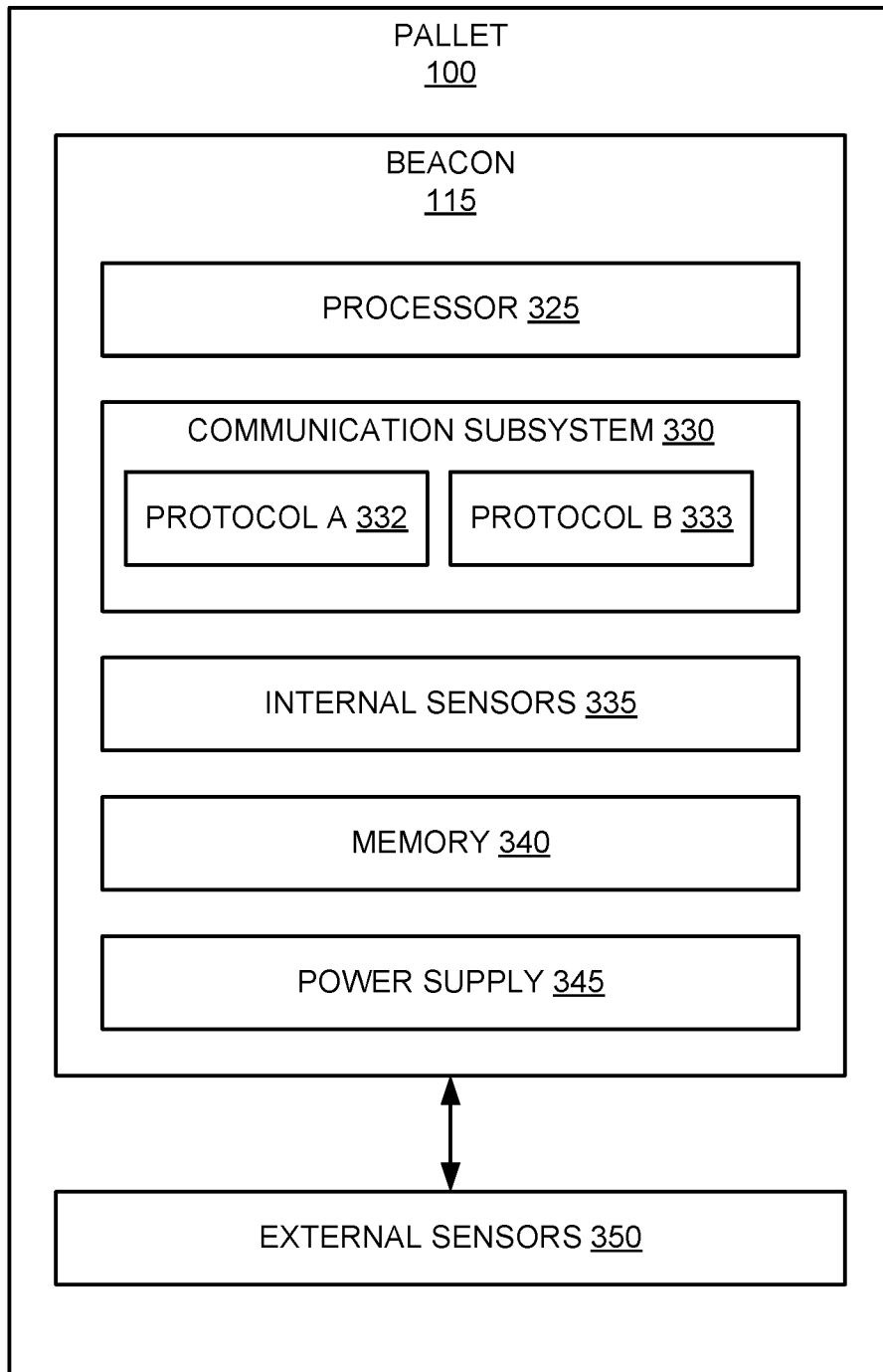

FIG. 3

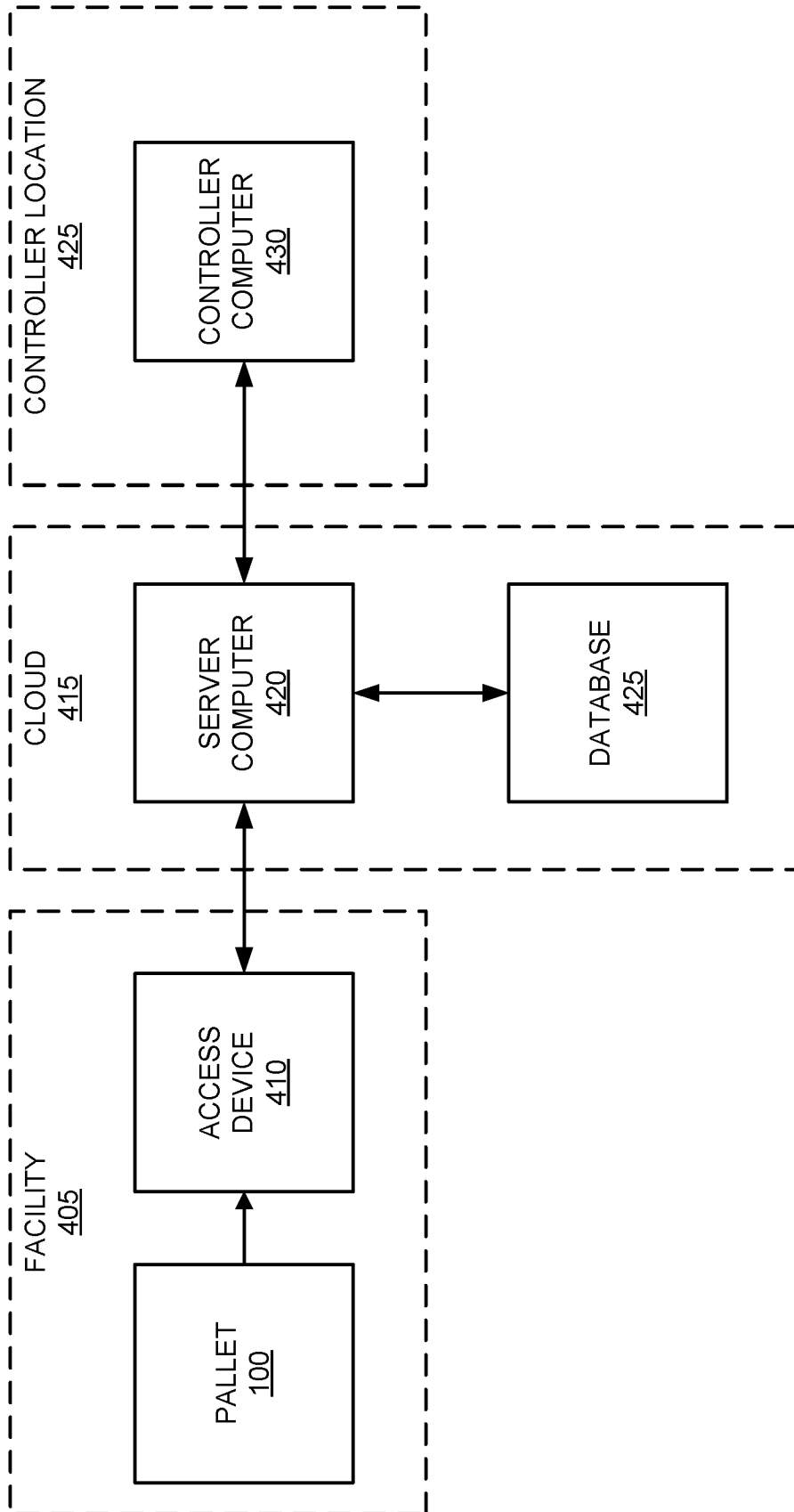

FIG. 4

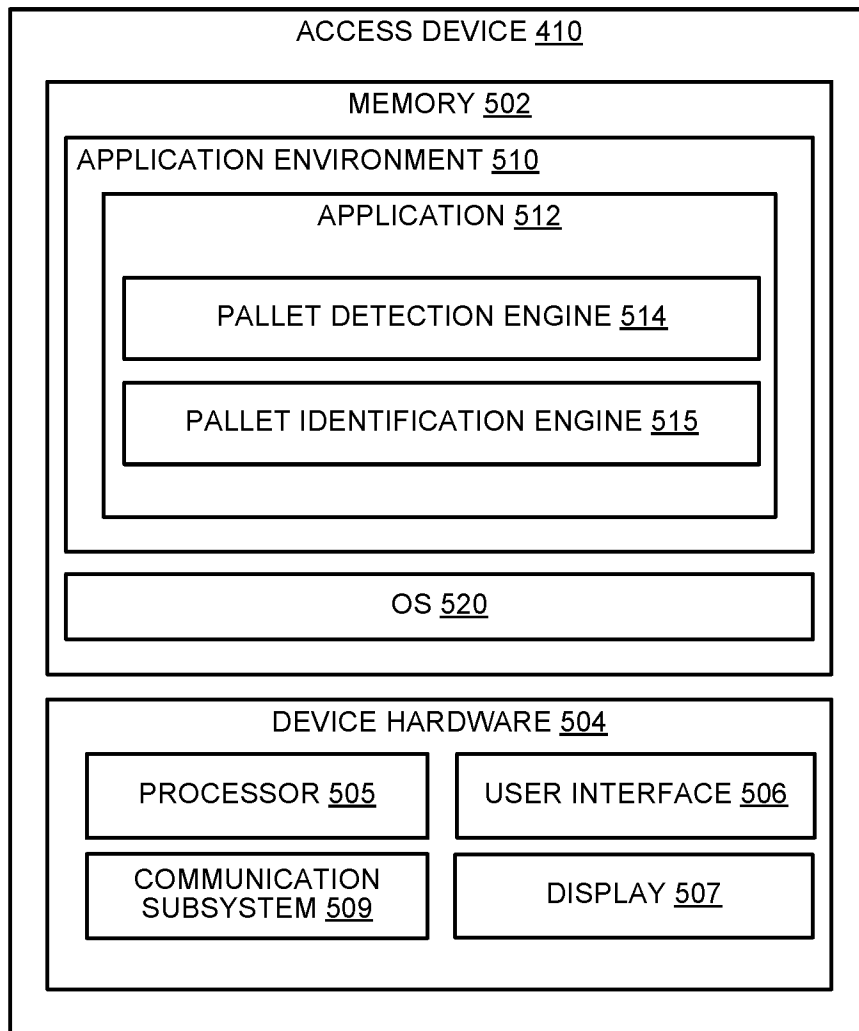

FIG. 5

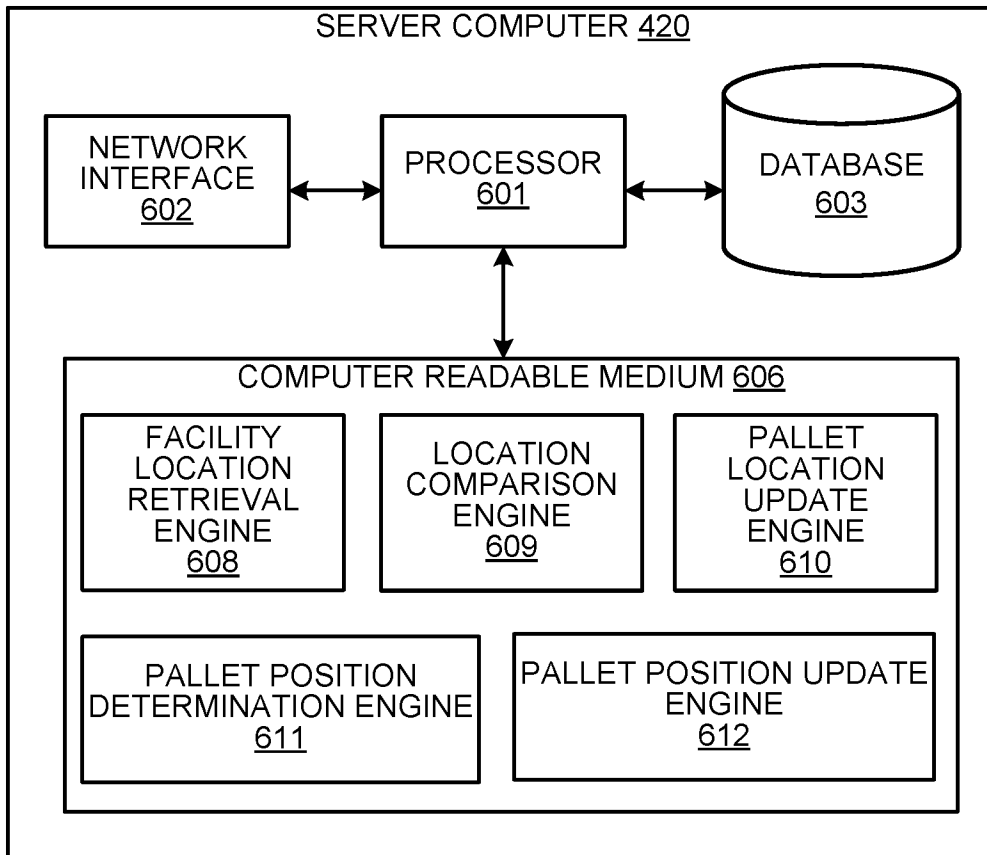

FIG. 6

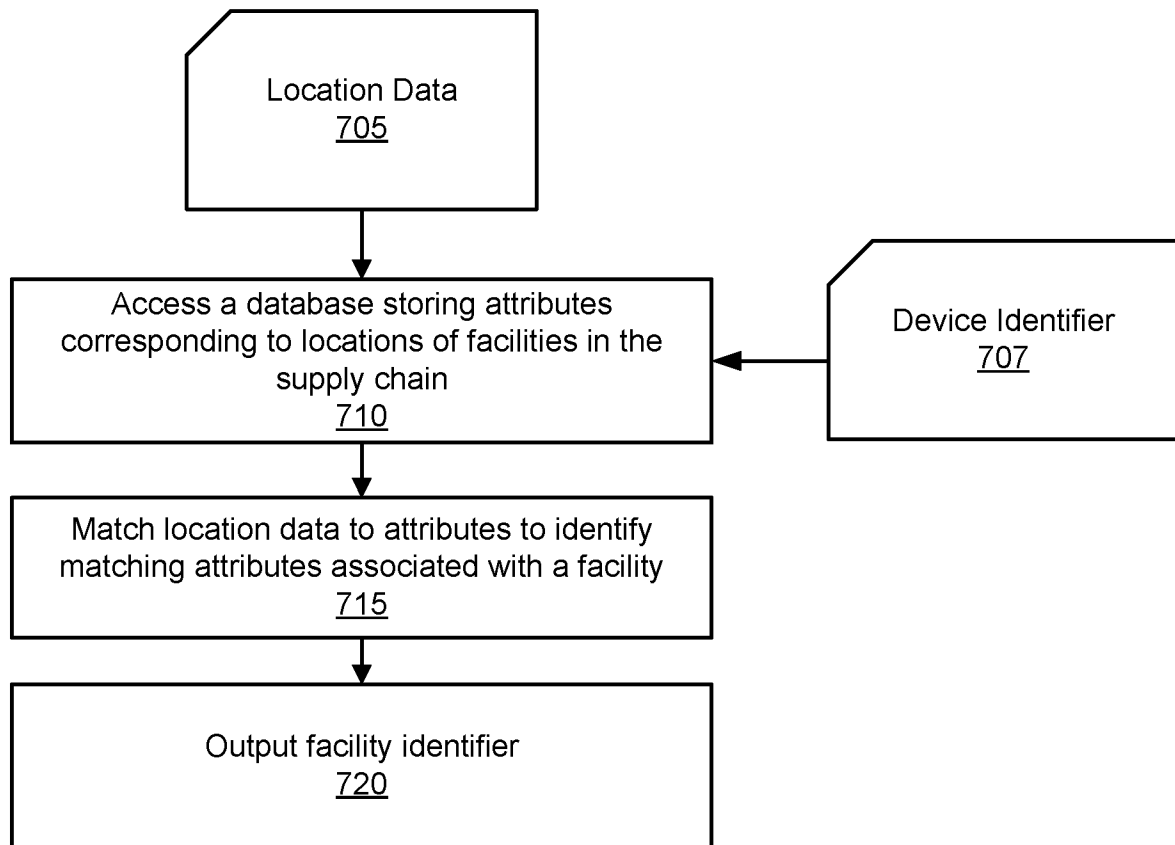

FIG. 7

INTERNATIONAL SEARCH REPORT

International application No
PCT/US2018/030672

A. CLASSIFICATION OF SUBJECT MATTER
INV. G06Q10/08 G06Q50/28
ADD.
According to International Patent Classification (IPC) or to both national classification and IPC

B. FIELDS SEARCHED
Minimum documentation searched (classification system followed by classification symbols)
G06Q H04W H04L G01C G01S

Documentation searched other than minimum documentation to the extent that such documents are included in the fields searched

Electronic data base consulted during the international search (name of data base and, where practicable, search terms used)
EPO-Internal, WPI Data

C. DOCUMENTS CONSIDERED TO BE RELEVANT

Category*	Citation of document, with indication, where appropriate, of the relevant passages	Relevant to claim No.
X	US 2017/019264 A1 (NUGENT EDWARD [US] ET AL) 19 January 2017 (2017-01-19) figures 2-11 paragraphs [0018] - [0058] paragraphs [0068] - [0076] -----	1-24
X	US 2012/105202 A1 (GITS PETER MICHAEL [US] ET AL) 3 May 2012 (2012-05-03) paragraphs [0012] - [0027] paragraphs [0035], [0037] - [0045], [0051] figures 1-3, 6 -----	1-24
X	US 2012/239499 A1 (ZUGHAIB EDWARD [US] ET AL) 20 September 2012 (2012-09-20) paragraphs [0030] - [0043], [0097]; figures 1-4C ----- -/--	1-24

Further documents are listed in the continuation of Box C.

See patent family annex.

* Special categories of cited documents :

- "A" document defining the general state of the art which is not considered to be of particular relevance
- "E" earlier application or patent but published on or after the international filing date
- "L" document which may throw doubts on priority claim(s) or which is cited to establish the publication date of another citation or other special reason (as specified)
- "O" document referring to an oral disclosure, use, exhibition or other means
- "P" document published prior to the international filing date but later than the priority date claimed

"T" later document published after the international filing date or priority date and not in conflict with the application but cited to understand the principle or theory underlying the invention

"X" document of particular relevance; the claimed invention cannot be considered novel or cannot be considered to involve an inventive step when the document is taken alone

"Y" document of particular relevance; the claimed invention cannot be considered to involve an inventive step when the document is combined with one or more other such documents, such combination being obvious to a person skilled in the art

"&" document member of the same patent family

Date of the actual completion of the international search 3 July 2018	Date of mailing of the international search report 13/07/2018
Name and mailing address of the ISA/ European Patent Office, P.B. 5818 Patentlaan 2 NL - 2280 HV Rijswijk Tel. (+31-70) 340-2040, Fax: (+31-70) 340-3016	Authorized officer Mülthaler, Evelyn

INTERNATIONAL SEARCH REPORT

International application No
PCT/US2018/030672

C(Continuation). DOCUMENTS CONSIDERED TO BE RELEVANT		
Category*	Citation of document, with indication, where appropriate, of the relevant passages	Relevant to claim No.
Y	US 2002/070862 A1 (FRANCIS ROBERT C [US] ET AL) 13 June 2002 (2002-06-13) figures 1, 3 paragraphs [0008] - [0024] paragraphs [0040] - [0049] -----	1-24
Y	US 2016/205654 A1 (ROBINSON JR DOUGLAS EUGENE [US]) 14 July 2016 (2016-07-14) paragraphs [0020] - [0024] paragraphs [0037] - [0042] paragraphs [0045] - [0052] paragraphs [0056], [0063] - [0068] paragraphs [0086] - [0097] paragraphs [0122] - [0126] paragraphs [0170], [0209] figures 1, 3, 5, 9, 11 -----	1-24
Y	US 2016/198431 A1 (PATTABIRAMAN GANESH [US] ET AL) 7 July 2016 (2016-07-07) figures 1-6 paragraphs [0013] - [0015] -----	1-24
Y	US 2014/120945 A1 (SHARMA ABHINAV [US] ET AL) 1 May 2014 (2014-05-01) claims 1-6; figures 3A, 3B paragraphs [0014] - [0018] paragraphs [0035] - [0042] paragraph [0051] -----	1-24
Y	US 2014/062774 A1 (HALE GREGORY BROOKS [US] ET AL) 6 March 2014 (2014-03-06) paragraphs [0028] - [0055]; figures 1-3 -----	1-24

INTERNATIONAL SEARCH REPORT

Information on patent family members

International application No PCT/US2018/030672

Patent document cited in search report	Publication date	Patent family member(s)	Publication date
US 2017019264	A1	19-01-2017	US 2017019264 A1 19-01-2017 US 2018062869 A1 01-03-2018
US 2012105202	A1	03-05-2012	NONE
US 2012239499	A1	20-09-2012	NONE
US 2002070862	A1	13-06-2002	AR 031656 A1 24-09-2003 AU 5911601 A 24-06-2002 CA 2431878 A1 20-06-2002 CN 1479908 A 03-03-2004 EP 1342207 A1 10-09-2003 JP 5662409 B2 28-01-2015 JP 2004516205 A 03-06-2004 JP 2013075768 A 25-04-2013 KR 20040028692 A 03-04-2004 MX PA03005035 A 25-06-2004 MY 119893 A 29-07-2005 NZ 526107 A 24-12-2004 TW 565802 B 11-12-2003 US 2002070862 A1 13-06-2002 WO 0248955 A1 20-06-2002
US 2016205654	A1	14-07-2016	US 2016205654 A1 14-07-2016 US 2018146448 A1 24-05-2018 WO 2016112399 A1 14-07-2016
US 2016198431	A1	07-07-2016	CA 2903453 A1 25-09-2014 CN 105190345 A 23-12-2015 HK 1217994 A1 27-01-2017 KR 20150130988 A 24-11-2015 US 2014274151 A1 18-09-2014 US 2016198431 A1 07-07-2016 WO 2014151090 A2 25-09-2014
US 2014120945	A1	01-05-2014	CN 104755952 A 01-07-2015 EP 2914972 A1 09-09-2015 JP 6199402 B2 20-09-2017 JP 2016502652 A 28-01-2016 US 2014120945 A1 01-05-2014 WO 2014070398 A1 08-05-2014
US 2014062774	A1	06-03-2014	NONE