

FIG. 1

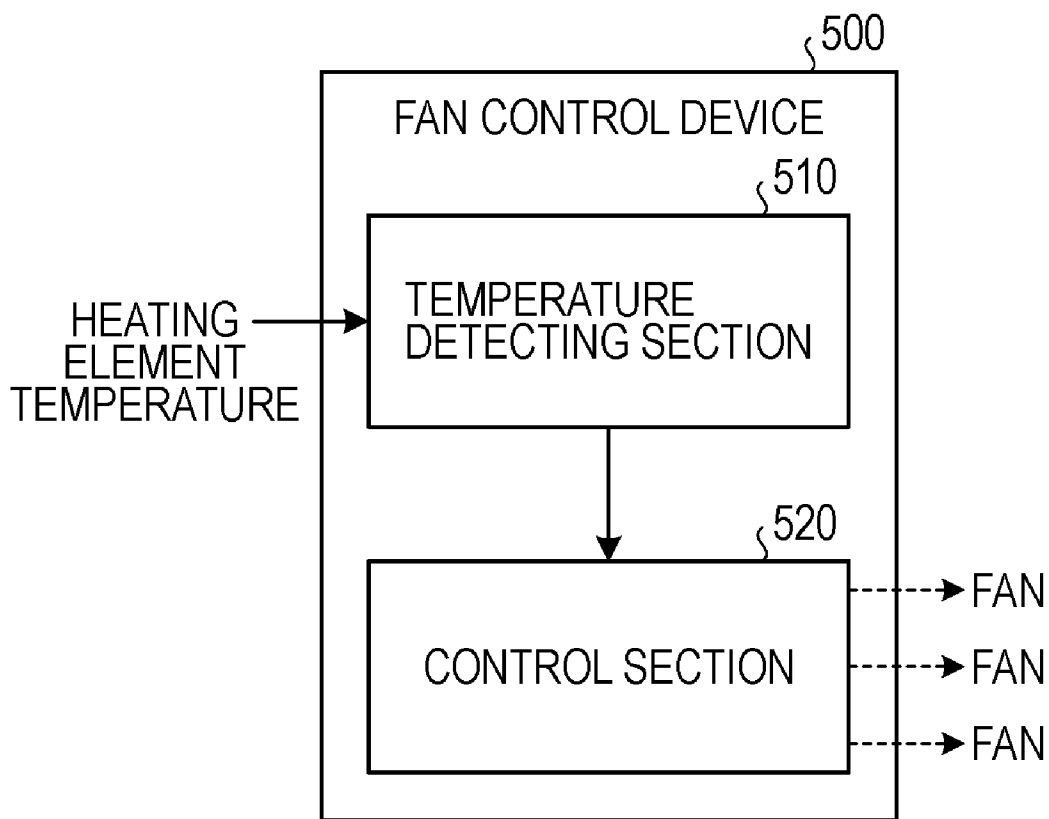

FIG. 2

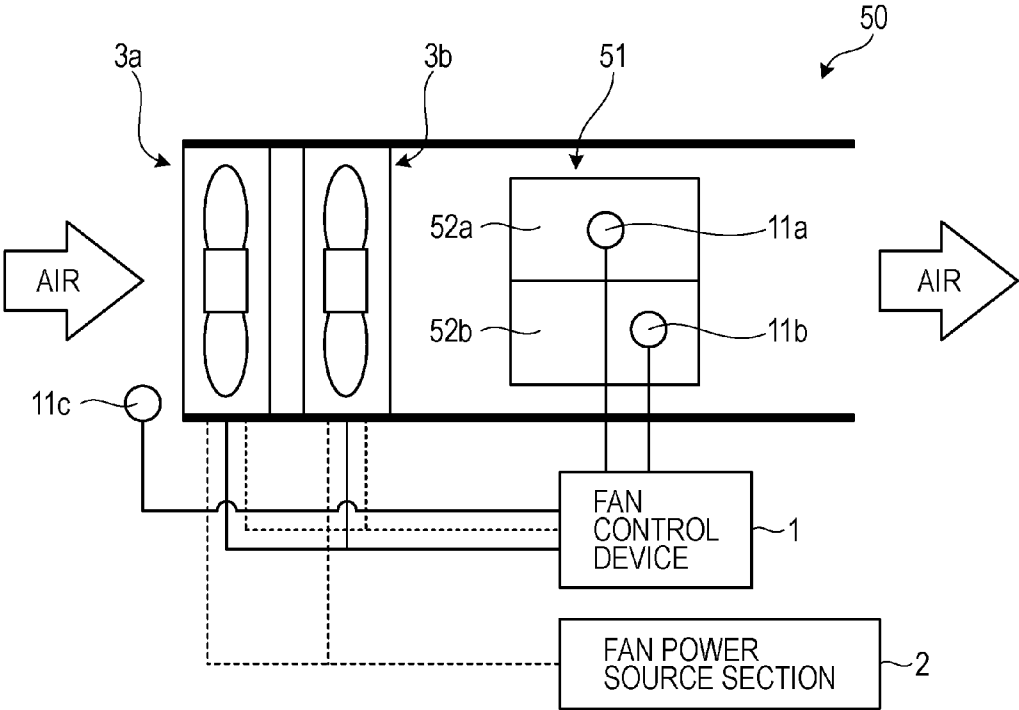

FIG. 3

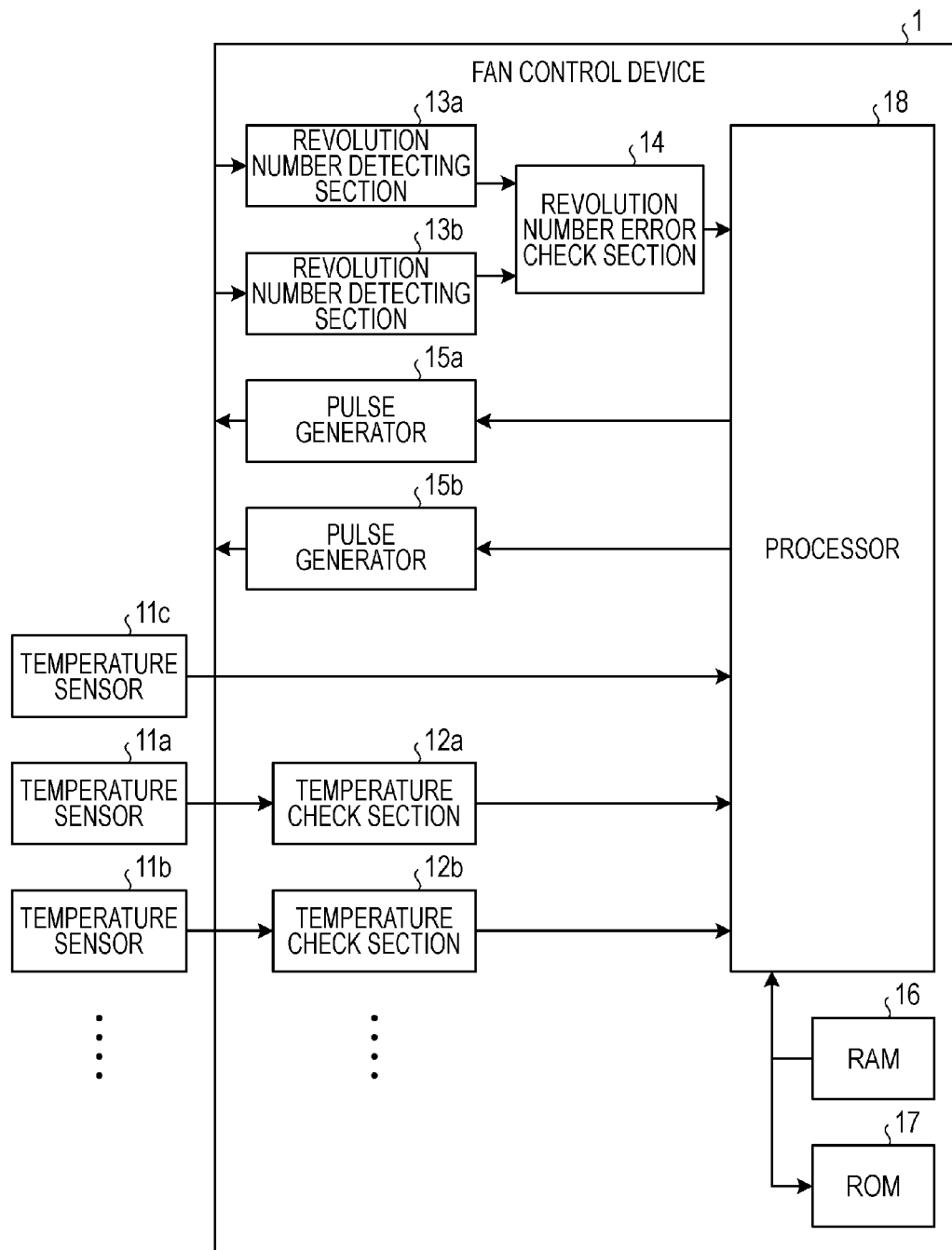

FIG. 4

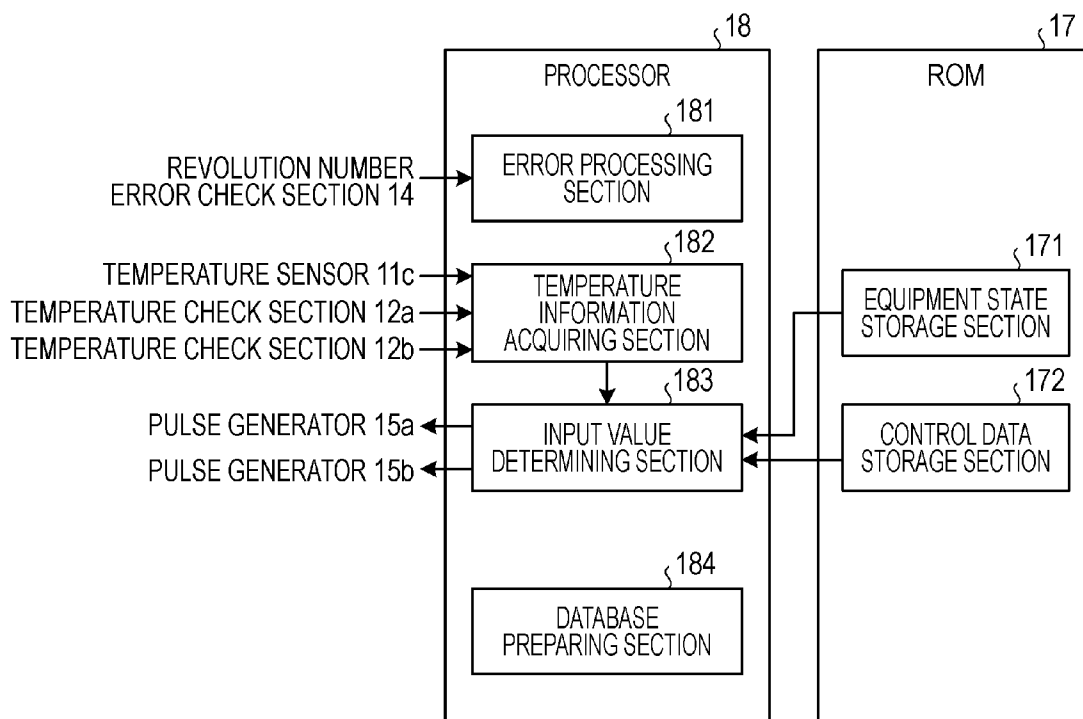

FIG. 5

61

SYSTEM IMPEDANCE	EQUIPMENT STATE SPECIFICATION FLAG
A	○
B	-
C	-

FIG. 6

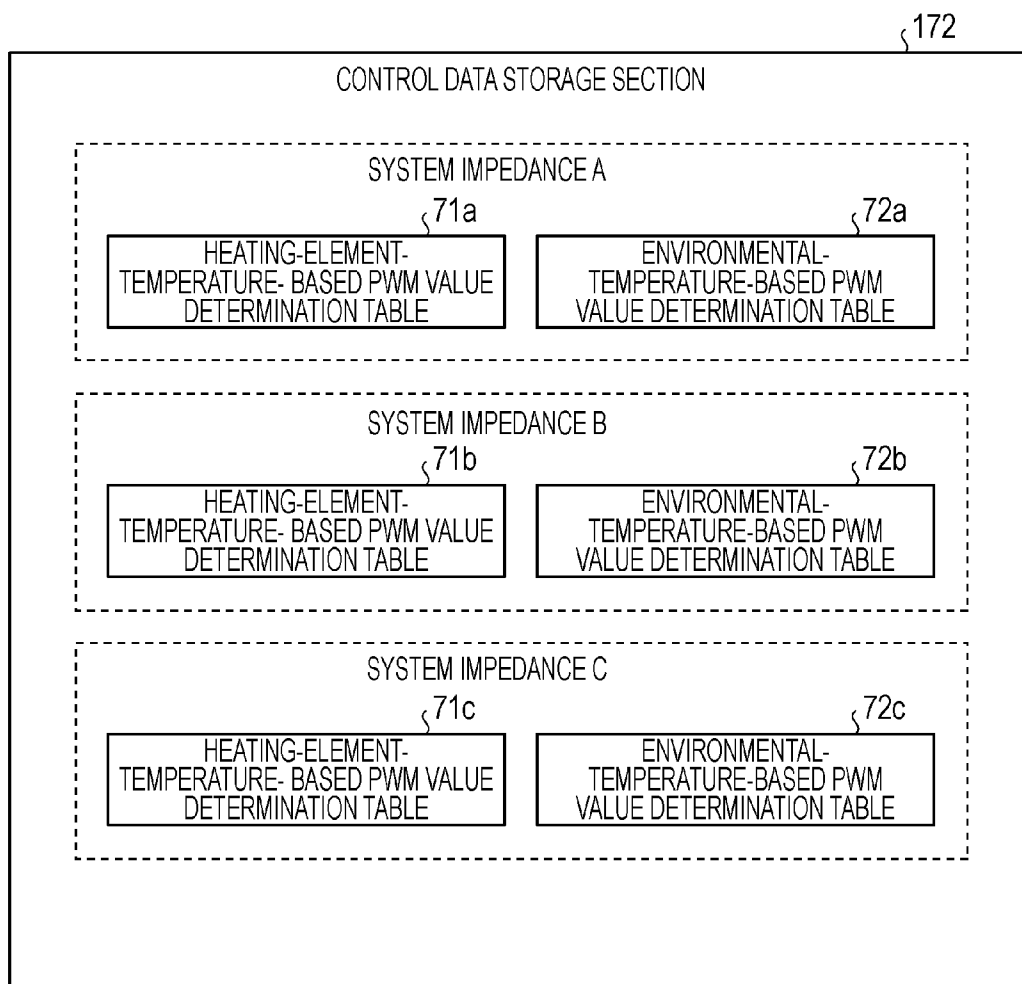

FIG. 7A

71a

HEATING ELEMENT TEMPERATURE	COMMON REVOLUTION NUMBER	FRONT-STAGE PWM VALUE	REAR-STAGE PWM VALUE
A	aaa	Nfa	Nra
B	bbb	Nfb	Nrb
C	ccc	Nfc	Nrc
D	ddd	Nfd	Nrd
E	eee	Nfe	Nre
...

FIG. 7B

72a

ENVIRONMENTAL TEMPERATURE	COMMON REVOLUTION NUMBER	FRONT-STAGE PWM VALUE	REAR-STAGE PWM VALUE
F	fff	Nff	Nrf
G	ggg	Nfg	Nrg
H	hhh	Nfh	Nrh
I	iii	Nfi	Nri
J	jjj	Nfj	Nrj
...

FIG. 8

1001

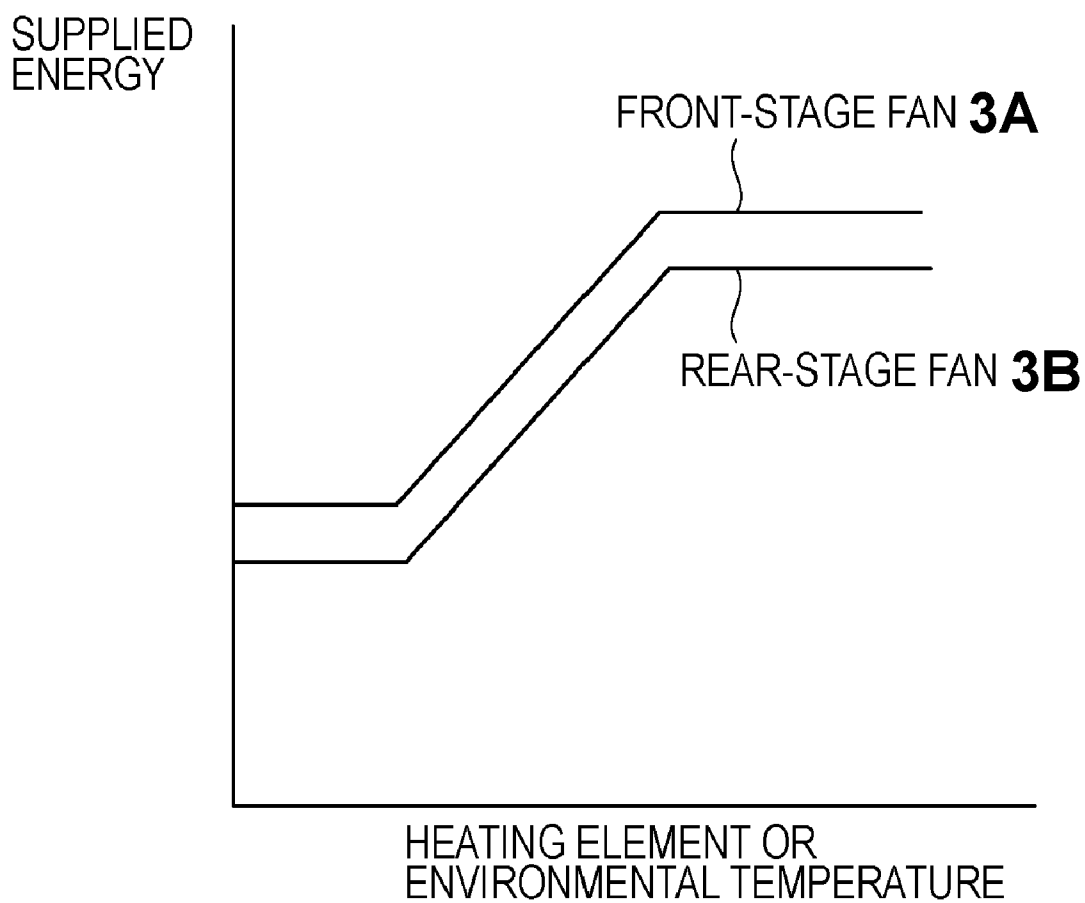

FIG. 9

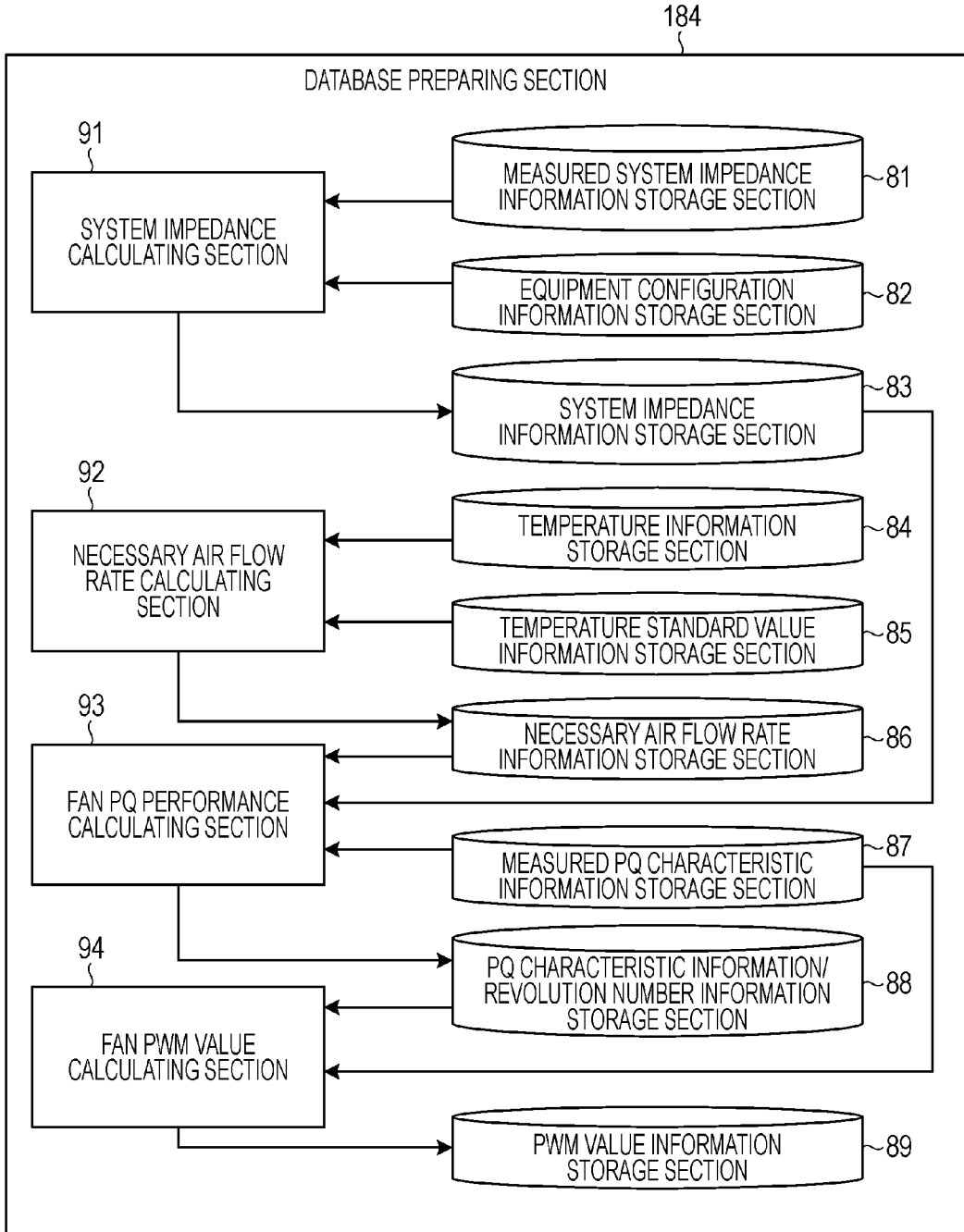

FIG. 10

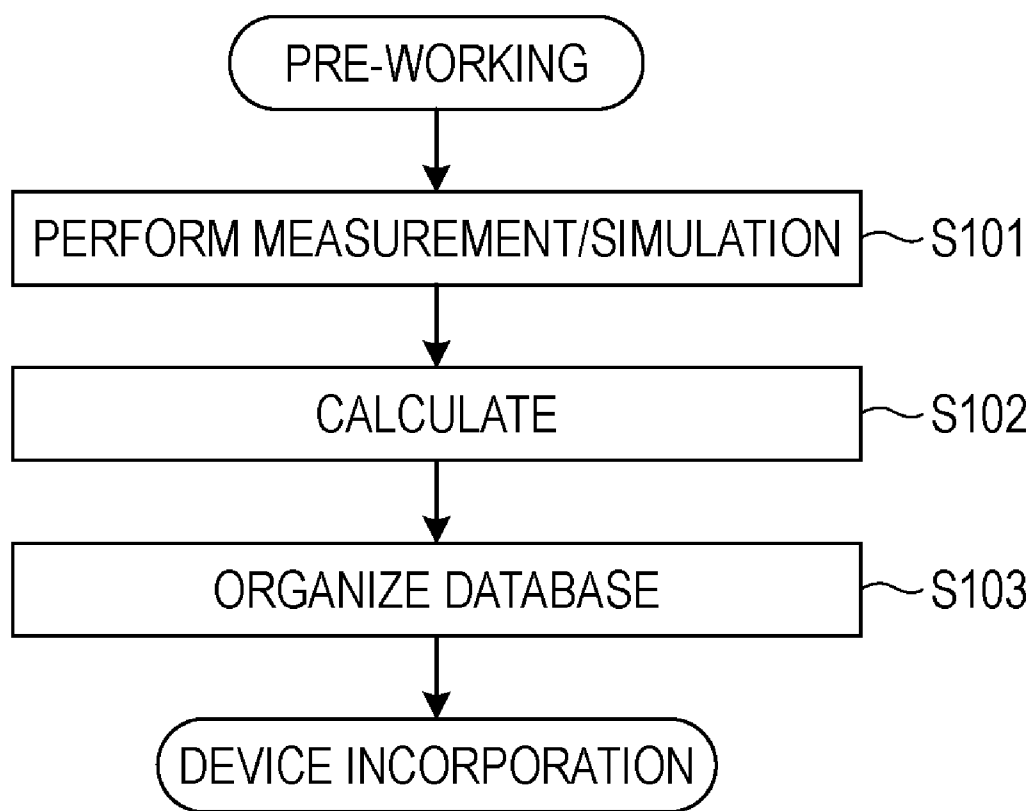

FIG. 11

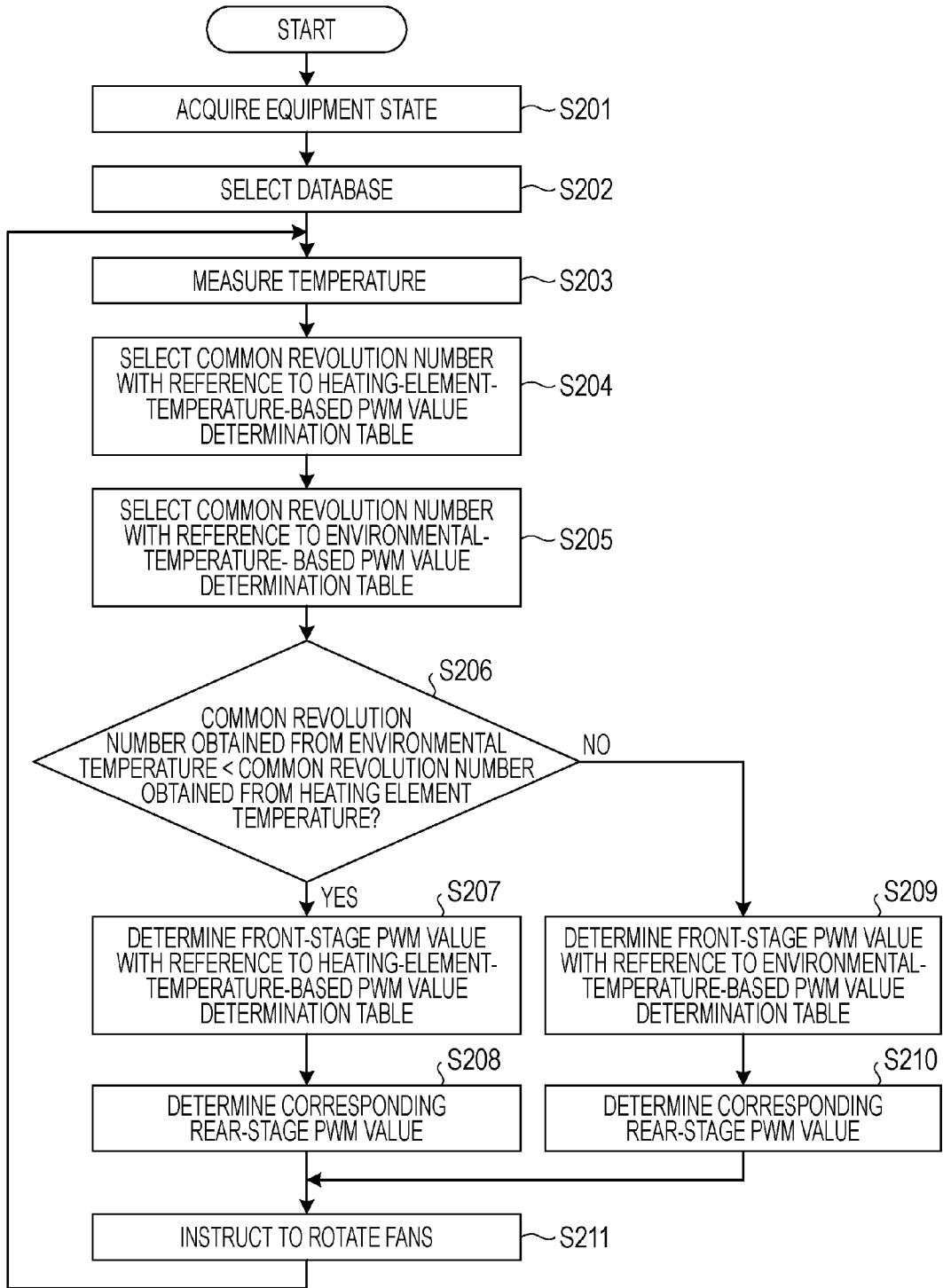

FIG. 12

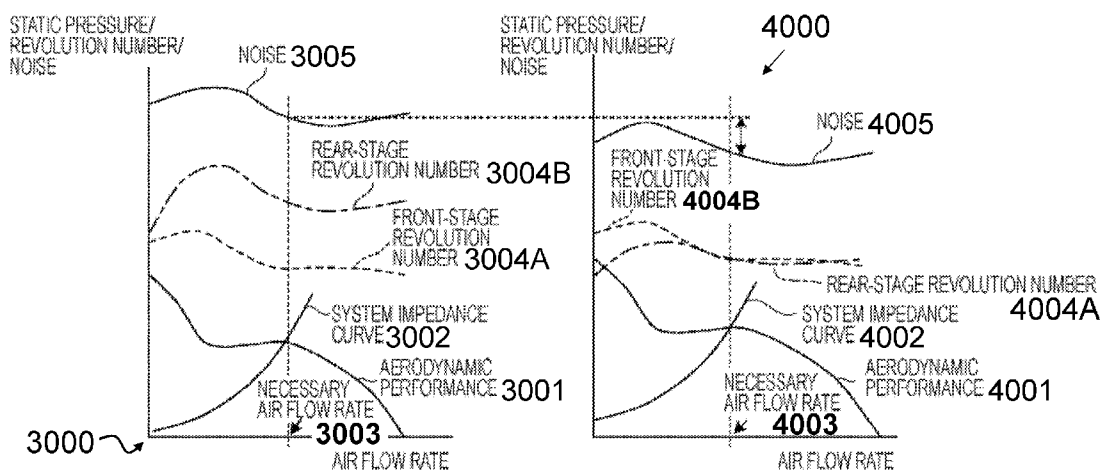

FIG. 13

3010

MEASUREMENT CONDITION A (DISPOSE TWO FANS OF THE SAME TYPE IN SERIES)	CONDITION A-1	SUPPLY VOLTAGES OF THE SAME AMOUNT TO FRONT-STAGE AND REAR-STAGE FANS
	CONDITION A-2	ATTAIN THE SAME AIR FLOW RATE AS THAT ON CONDITION A-1 CONTROL VOLTAGES SUCH THAT RATIO OF REVOLUTION NUMBER OF FRONT-STAGE FAN TO REVOLUTION NUMBER OF REAR-STAGE FAN IS 1:1
	CONDITION A-3	ATTAIN THE SAME AIR FLOW RATE AS THAT ON CONDITION A-1 CONTROL VOLTAGES SUCH THAT RATIO OF REVOLUTION NUMBER OF FRONT-STAGE FAN TO REVOLUTION NUMBER OF REAR-STAGE FAN IS 1:0.9
MEASUREMENT CONDITION B (DISPOSE TWO FANS OF THE SAME TYPE IN SERIES AND FOUR FANS OF THE SAME TYPE IN PARALLEL)	CONDITION B-1	SUPPLY VOLTAGES OF THE SAME AMOUNT TO FRONT-STAGE AND REAR-STAGE FANS
	CONDITION B-2	ATTAIN THE SAME AIR FLOW RATE AS THAT ON CONDITION B-1 CONTROL VOLTAGES SUCH THAT RATIO OF REVOLUTION NUMBER OF FRONT-STAGE FAN TO REVOLUTION NUMBER OF REAR-STAGE FAN IS 1:1
	CONDITION B-3	SUPPLY VOLTAGES OF THE SAME AMOUNT TO FRONT-STAGE AND REAR-STAGE FANS (VOLTAGES DIFFERENT FROM THOSE ON CONDITION B-1)
	CONDITION B-4	ATTAIN THE SAME AIR FLOW RATE AS THAT ON CONDITION B-3 CONTROL VOLTAGES SUCH THAT RATIO OF REVOLUTION NUMBER OF FRONT-STAGE FAN TO REVOLUTION NUMBER OF REAR-STAGE FAN IS 1:1

FIG. 14A

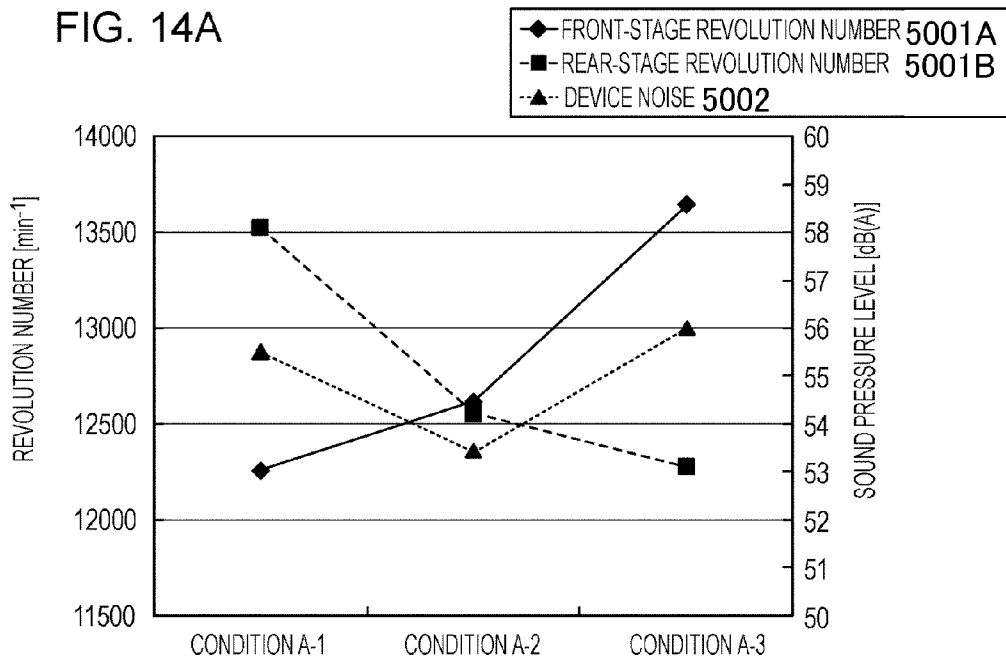

FIG. 14B

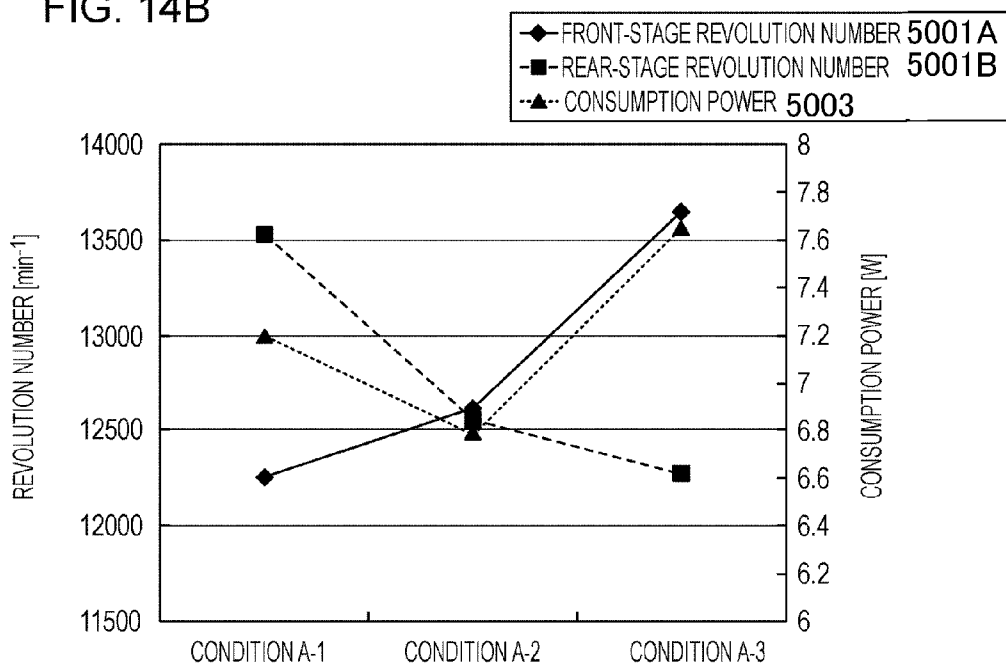

FIG. 14C

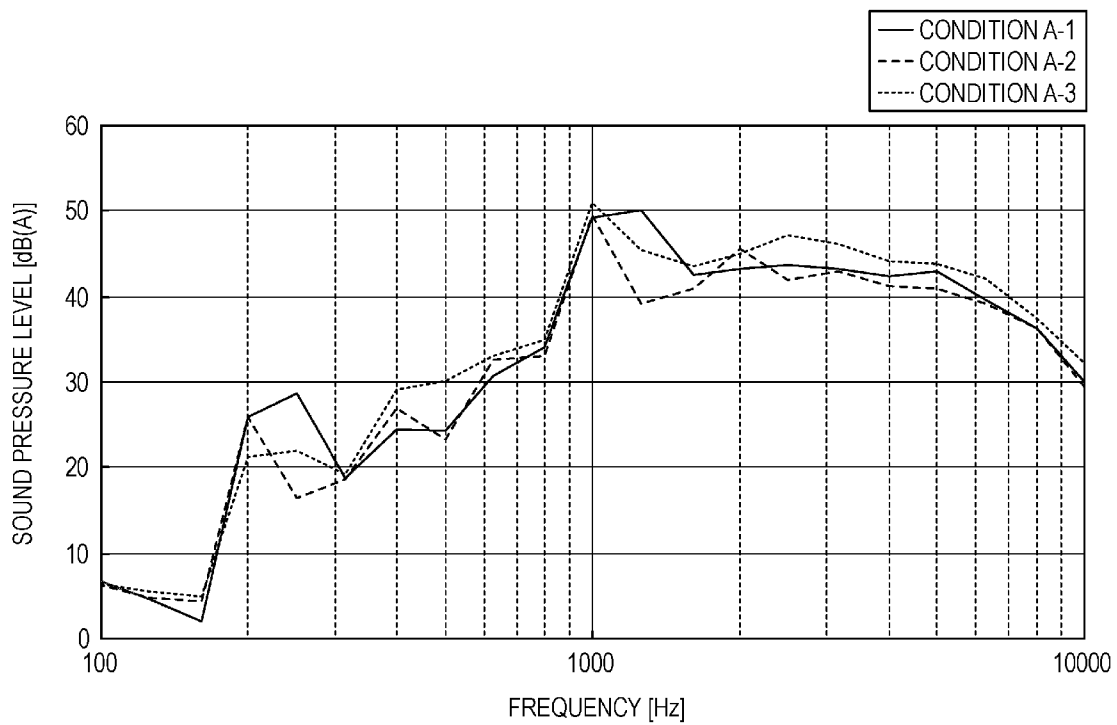

FIG. 15A

{ DEVICE AIR FLOW RATE [m³/min] 0.122
 { DEVICE NOISE [dB(A)] 55.5

3020A

FAN NO.	1 FRONT-STAGE FAN	2 REAR-STAGE FAN	RATIO OF FRONT-STAGE FAN REVOLUTION NUMBER TO REAR-STAGE FAN REVOLUTION NUMBER	TOTAL CONSUMPTION POWER OF FANS
FAN VOLTAGE [V]	10	10		
FAN CURRENT [A]	0.41	0.31		
FAN POWER [W]	4.1	3.1		
FAN REVOLUTION NUMBER [min ⁻¹]	12257	13523		

FIG. 15B

{ DEVICE AIR FLOW RATE [m³/min] 0.122
 { DEVICE NOISE [dB(A)] 53.4

3020B

FAN NO.	1 FRONT-STAGE FAN	2 REAR-STAGE FAN	RATIO OF FRONT-STAGE FAN REVOLUTION NUMBER TO REAR-STAGE FAN REVOLUTION NUMBER	TOTAL CONSUMPTION POWER OF FANS
FAN VOLTAGE [V]	10.3	9.1		
FAN CURRENT [A]	0.42	0.27		
FAN POWER [W]	4.326	2.457		
FAN REVOLUTION NUMBER [min ⁻¹]	12615	12555		

FIG. 15C

{ DEVICE AIR FLOW RATE [m³/min] 0.122
 { DEVICE NOISE [dB(A)] 56

3020C

FAN NO.	1 FRONT-STAGE FAN	2 REAR-STAGE FAN	RATIO OF FRONT-STAGE FAN REVOLUTION NUMBER TO REAR-STAGE FAN REVOLUTION NUMBER	TOTAL CONSUMPTION POWER OF FANS
FAN VOLTAGE [V]	11.4	8.7		
FAN CURRENT [A]	0.48	0.25		
FAN POWER [W]	5.472	2.175		
FAN REVOLUTION NUMBER [min ⁻¹]	13643	12277		

FIG. 16A

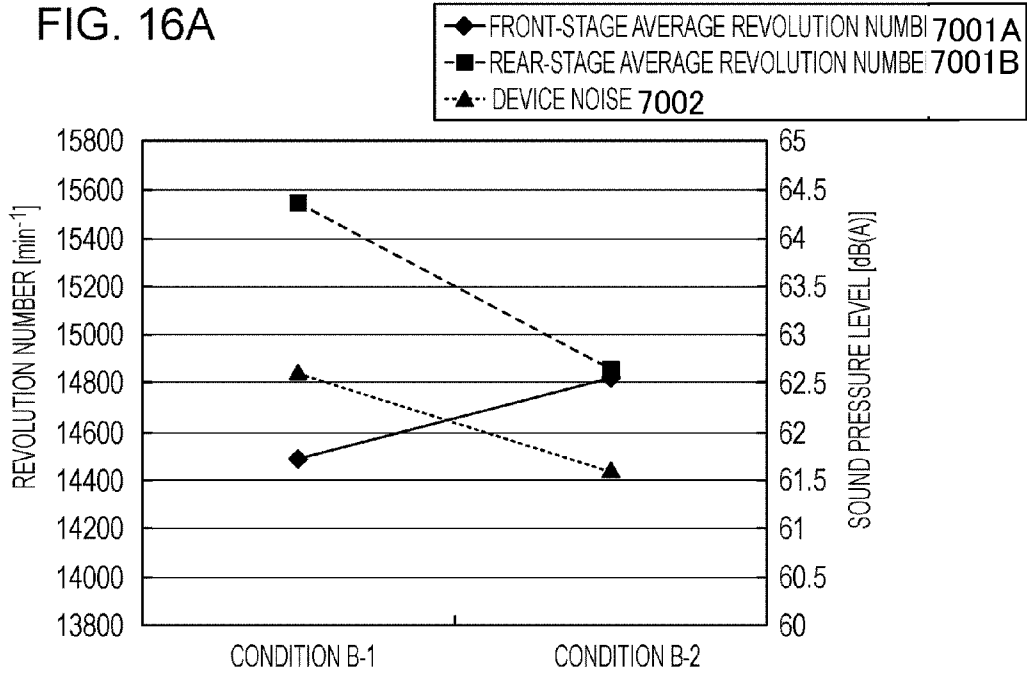

FIG. 16B

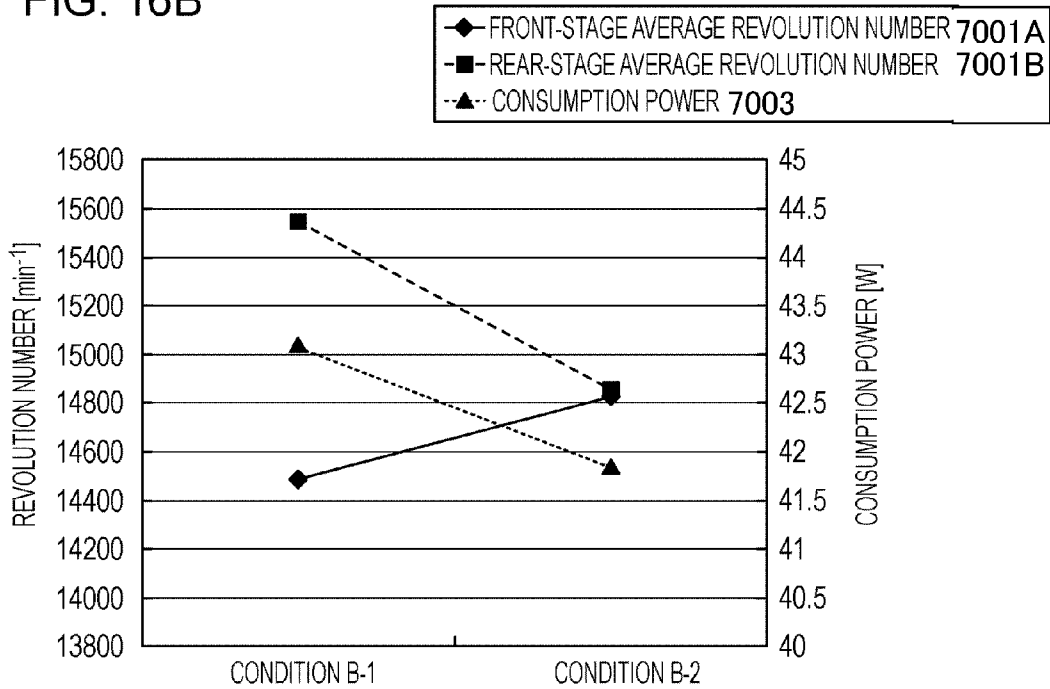

FIG. 16C

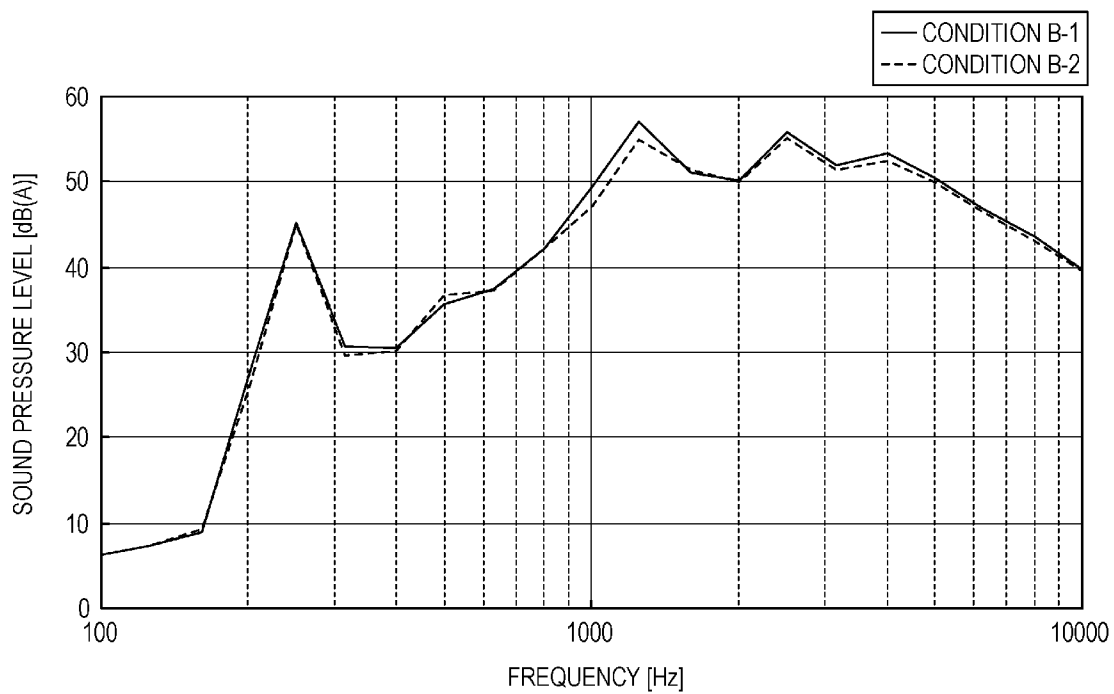

FIG. 17A

DEVICE AIR FLOW RATE [m³/min] 0.83
 DEVICE NOISE [dB(A)] 62.6

3030

FAN NO.	1 FRONT- STAGE FAN	2 REAR- STAGE FAN	4 FRONT- STAGE FAN	5 REAR- STAGE FAN	7 FRONT- STAGE FAN	8 REAR- STAGE FAN	10 FRONT- STAGE FAN	11 REAR- STAGE FAN	FRONT- STAGE AVERAGE	REAR- STAGE AVERAGE	RATIO OF FRONT- STAGE FAN REVOLUTION NUMBER TO REAR-STAGE FAN REVOLUTION NUMBER	TOTAL CONSUMPTION POWER OF FANS
FAN VOLTAGE [V]	12	12	12	12	12	12	12	12	12	12		
FAN CURRENT [A]	0.5	0.4	0.49	0.4	0.49	0.4	0.51	0.4	0.5	0.4		
FAN POWER [W]	6	4.8	5.88	4.8	5.88	4.8	6.12	4.8	6	4.8		
FAN REVOLUTION NUMBER [min ⁻¹]	14463	15497	14328	15569	14377	15560	14785	15566	14483	15548	1.07	43.08

FIG. 17B

DEVICE AIR FLOW RATE [m³/min] 0.83
 DEVICE NOISE [dB(A)] 61.6

3040

FAN NO.	1 FRONT- STAGE FAN	2 REAR- STAGE FAN	4 FRONT- STAGE FAN	5 REAR- STAGE FAN	7 FRONT- STAGE FAN	8 REAR- STAGE FAN	10 FRONT- STAGE FAN	11 REAR- STAGE FAN	FRONT- STAGE AVERAGE	REAR- STAGE AVERAGE	RATIO OF FRONT- STAGE FAN REVOLUTION NUMBER TO REAR-STAGE FAN REVOLUTION NUMBER	TOTAL CONSUMPTION POWER OF FANS
FAN VOLTAGE [V]	12.5	11.1	12.5	11.2	12.5	11.2	12.1	11.4	12.4	11.2		
FAN CURRENT [A]	0.53	0.36	0.51	0.36	0.51	0.35	0.51	0.38	0.5	0.4		
FAN POWER [W]	6.625	3.996	6.375	4.032	6.375	3.92	6.171	4.332	6.4	4.1		
FAN REVOLUTION NUMBER [min ⁻¹]	14878	14792	14786	14870	14856	14890	14780	14882	14825	14859	1.00	41.83

FIG. 18A

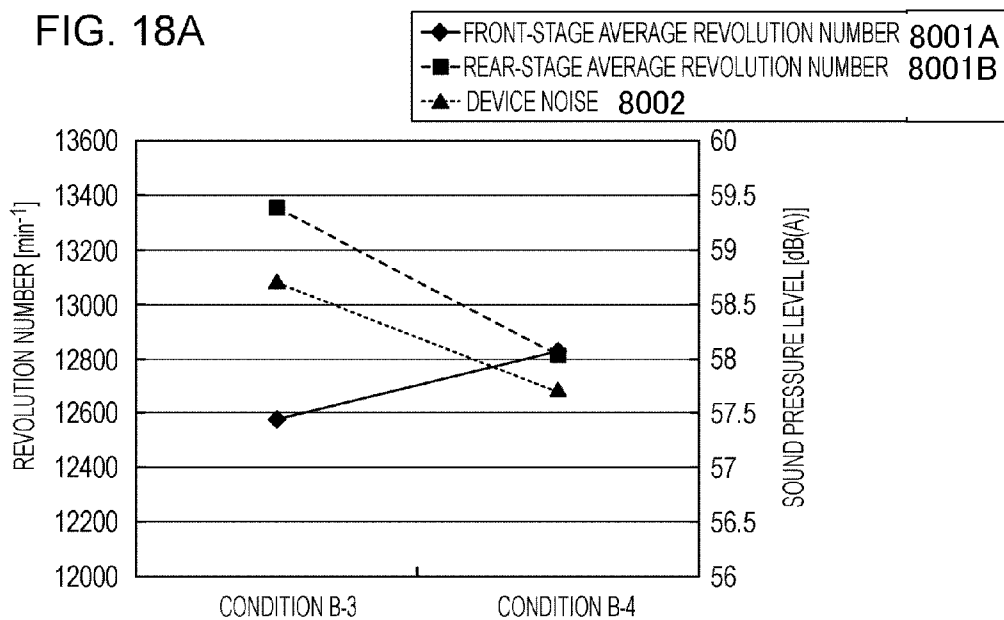

FIG. 18B

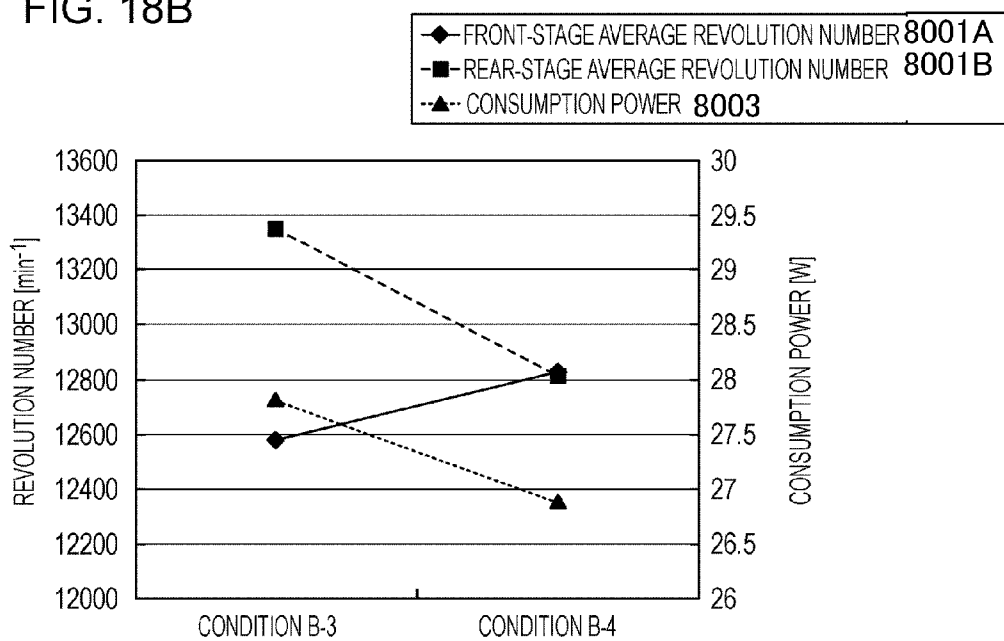

FIG. 18C

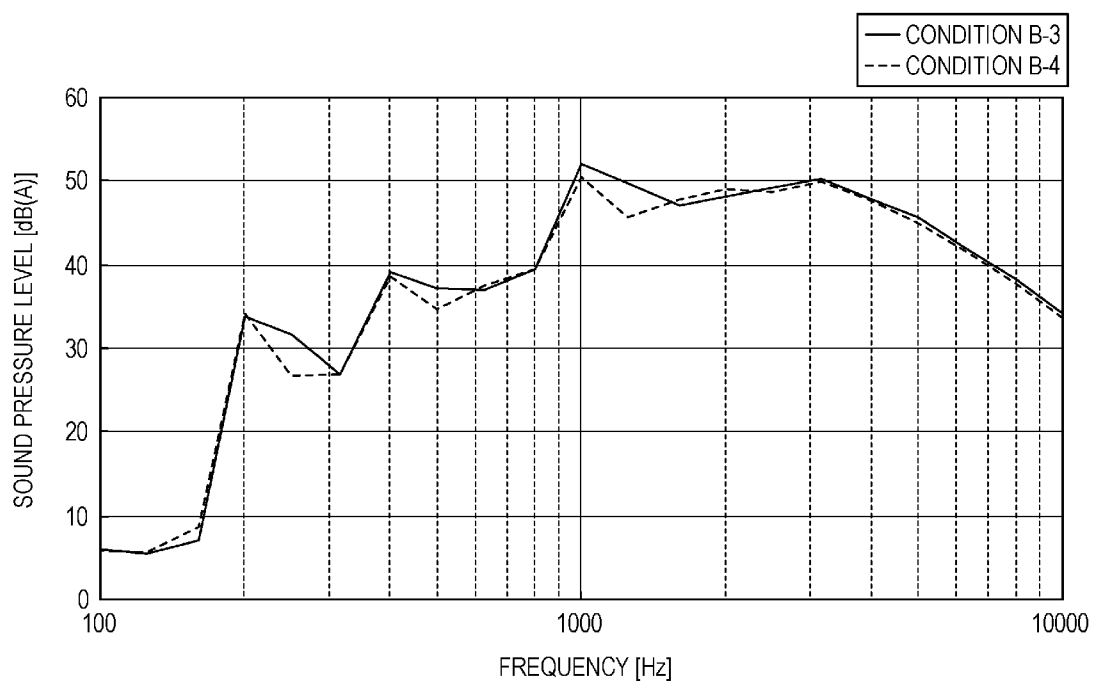

FIG. 19A

3050

DEVICE AIR FLOW RATE [m³/min] 0.69
 DEVICE NOISE [dB(A)] 58.7

FAN NO.	1 FRONT- STAGE FAN	2 REAR- STAGE FAN	4 FRONT- STAGE FAN	5 REAR- STAGE FAN	7 FRONT- STAGE FAN	8 REAR- STAGE FAN	10 FRONT- STAGE FAN	11 REAR- STAGE FAN	FRONT- STAGE AVERAGE	REAR- STAGE AVERAGE	RATIO OF FRONT- STAGE FAN REVOLUTION NUMBER TO REAR-STAGE FAN REVOLUTION NUMBER	TOTAL CONSUMPTION POWER OF FANS		
FAN VOLTAGE [V]	10	10	10	10	10	10	10	10	10	10				
FAN CURRENT [A]	0.39	0.32	0.38	0.31	0.37	0.3	0.4	0.31	0.4	0.3				
FAN POWER [W]	3.9	3.2	3.8	3.1	3.7	3	4	3.1	3.9	3.1				
FAN REVOLUTION NUMBER [min ⁻¹]	12493	13438	12440	13313	12541	13348	12828	13318	12576	13354	1.06	27.80		

FIG. 19B

3060

DEVICE AIR FLOW RATE [m³/min] 0.69
 DEVICE NOISE [dB(A)] 57.7

FAN NO.	1 FRONT- STAGE FAN	2 REAR- STAGE FAN	4 FRONT- STAGE FAN	5 REAR- STAGE FAN	7 FRONT- STAGE FAN	8 REAR- STAGE FAN	10 FRONT- STAGE FAN	11 REAR- STAGE FAN	FRONT- STAGE AVERAGE	REAR- STAGE AVERAGE	RATIO OF FRONT- STAGE FAN REVOLUTION NUMBER TO REAR-STAGE FAN REVOLUTION NUMBER	TOTAL CONSUMPTION POWER OF FANS
FAN VOLTAGE [V]	10.3	9.4	10.3	9.5	10.1	9.5	10	9.5	10.2	9.5		
FAN CURRENT [A]	0.4	0.29	0.39	0.29	0.37	0.28	0.4	0.3	0.4	0.3		
FAN POWER [W]	4.12	2.726	4.017	2.755	3.737	2.66	4	2.85	4	2.7		
FAN REVOLUTION NUMBER [min ⁻¹]	12870	12767	12802	12868	12777	12841	12853	12760	12826	12809	1.00	26.87

FIG. 20

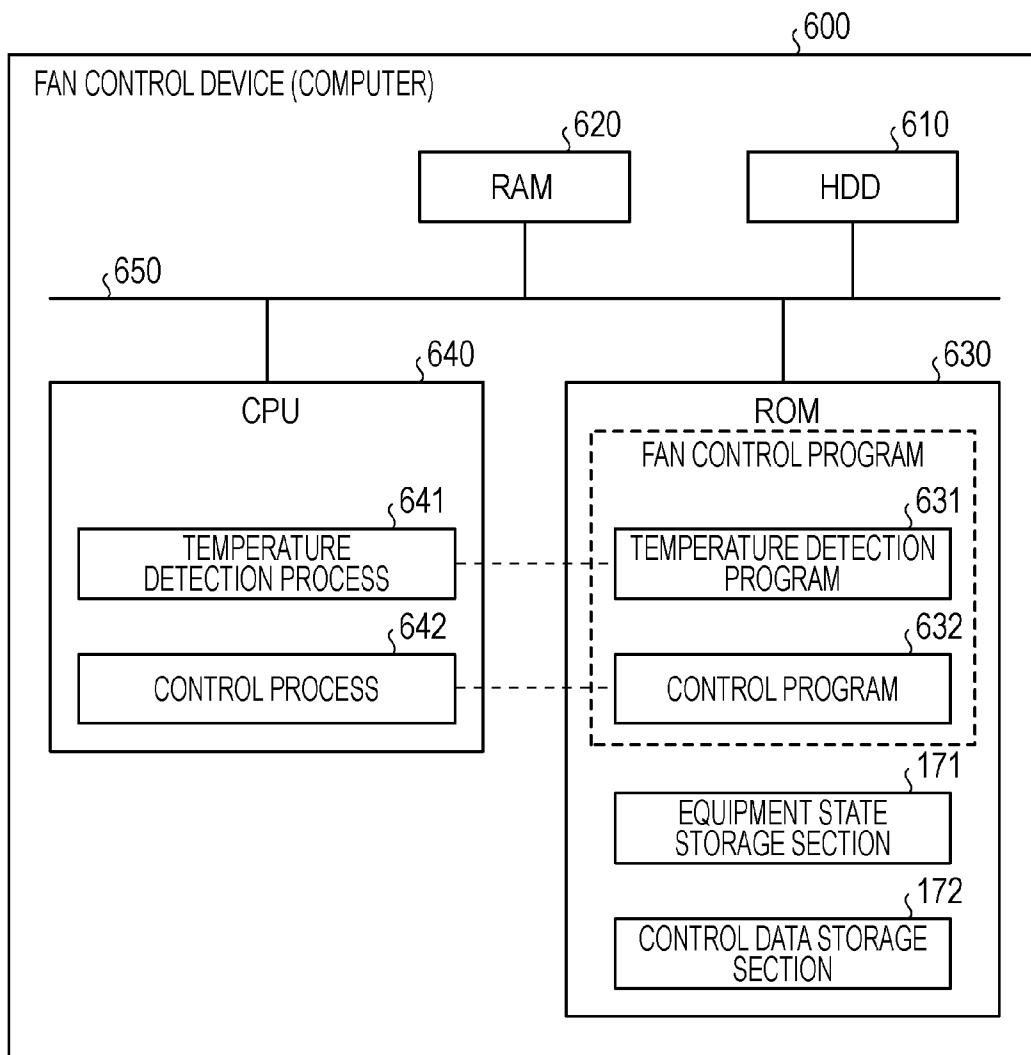

FIG. 21

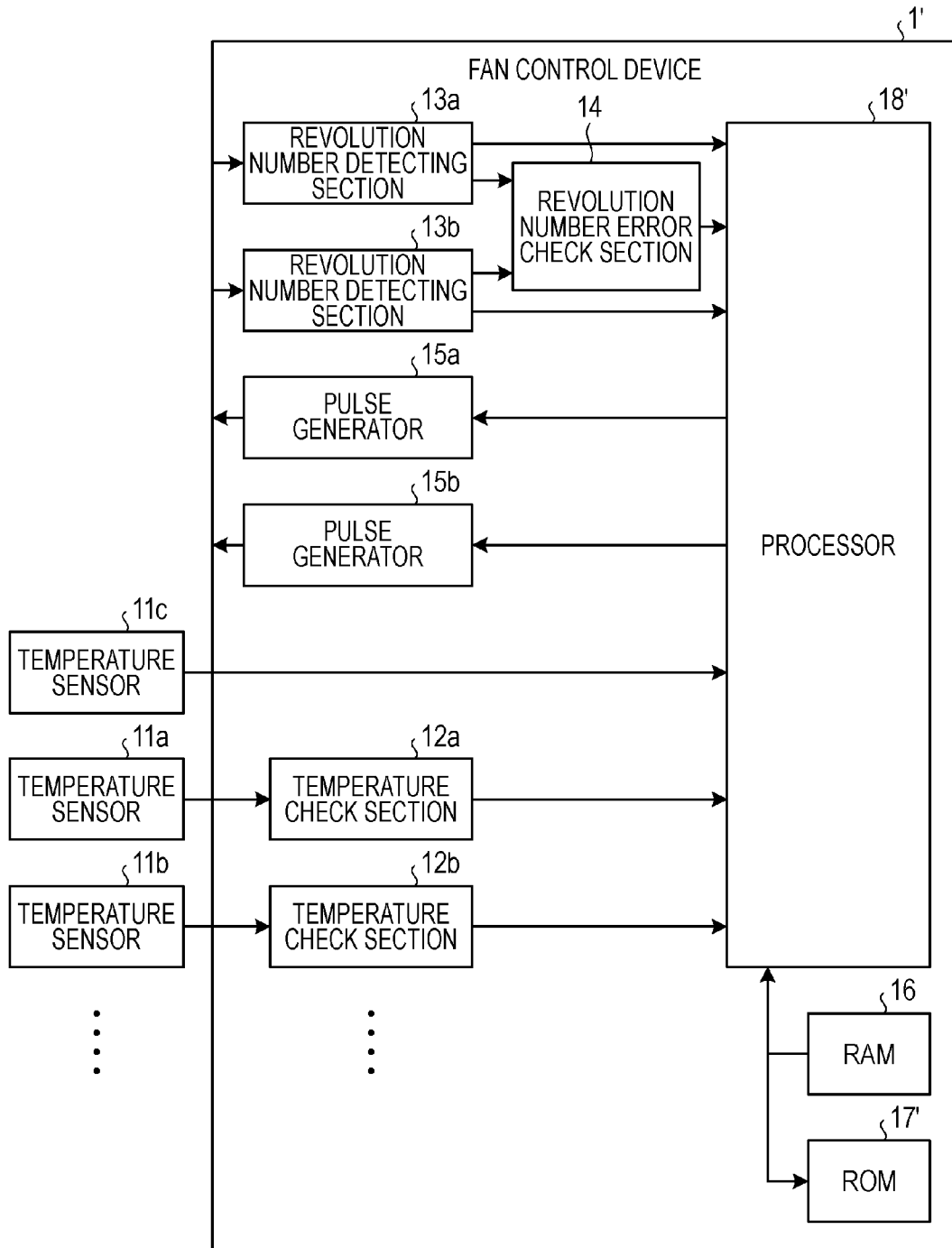

FIG. 22

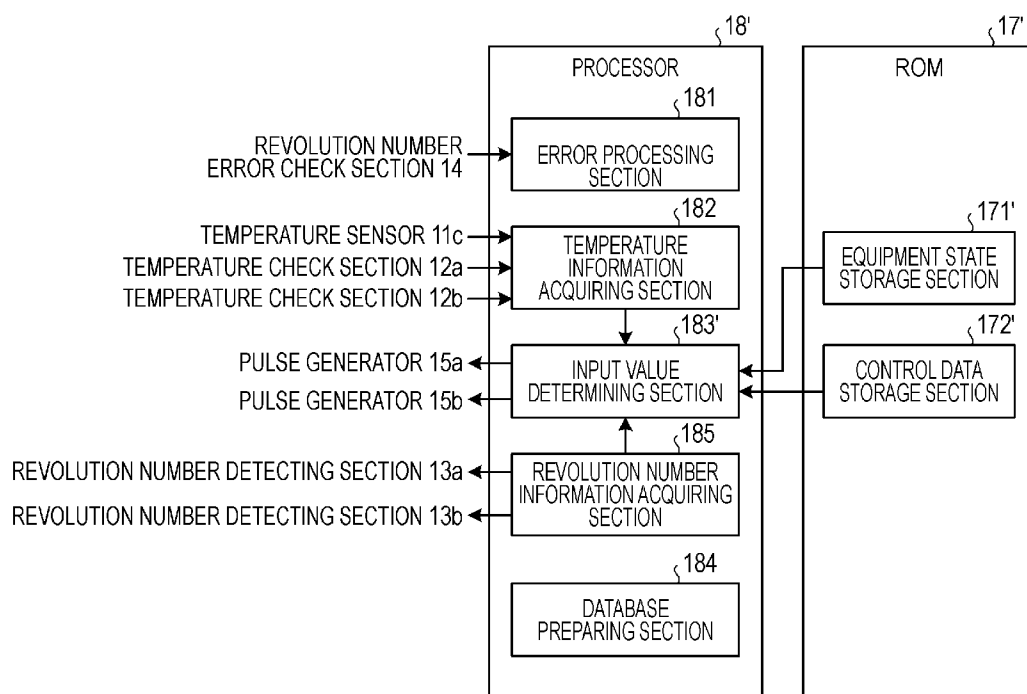

FIG. 23

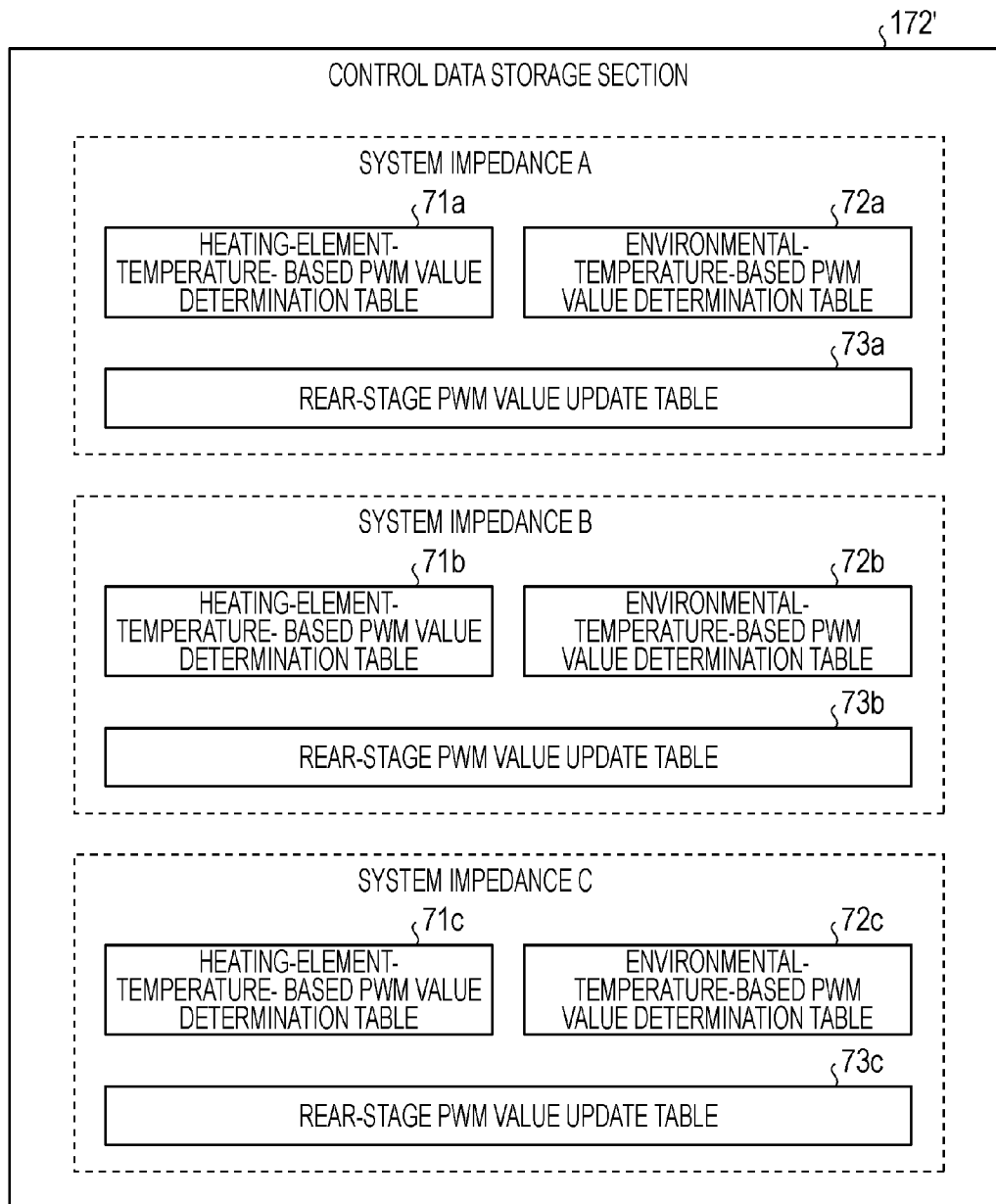

FIG. 24

73a
}

FRONT-STAGE REVOLUTION NUMBER	REAR-STAGE PWM VALUE
jjj	N _{rj}
kkk	N _{rk}
lll	N _{rl}
mmm	N _{rm}
...	...

FIG. 25

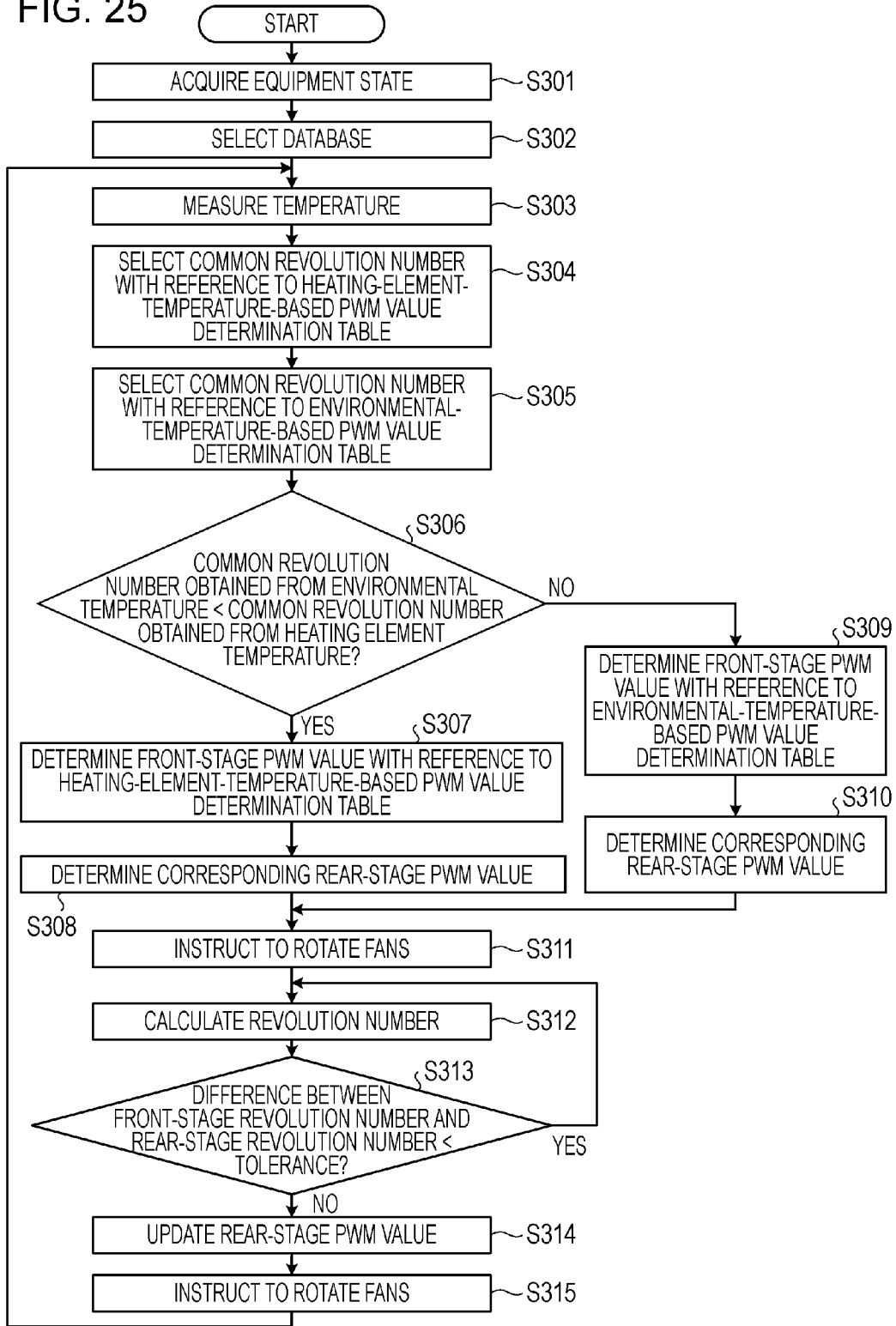

FIG. 26

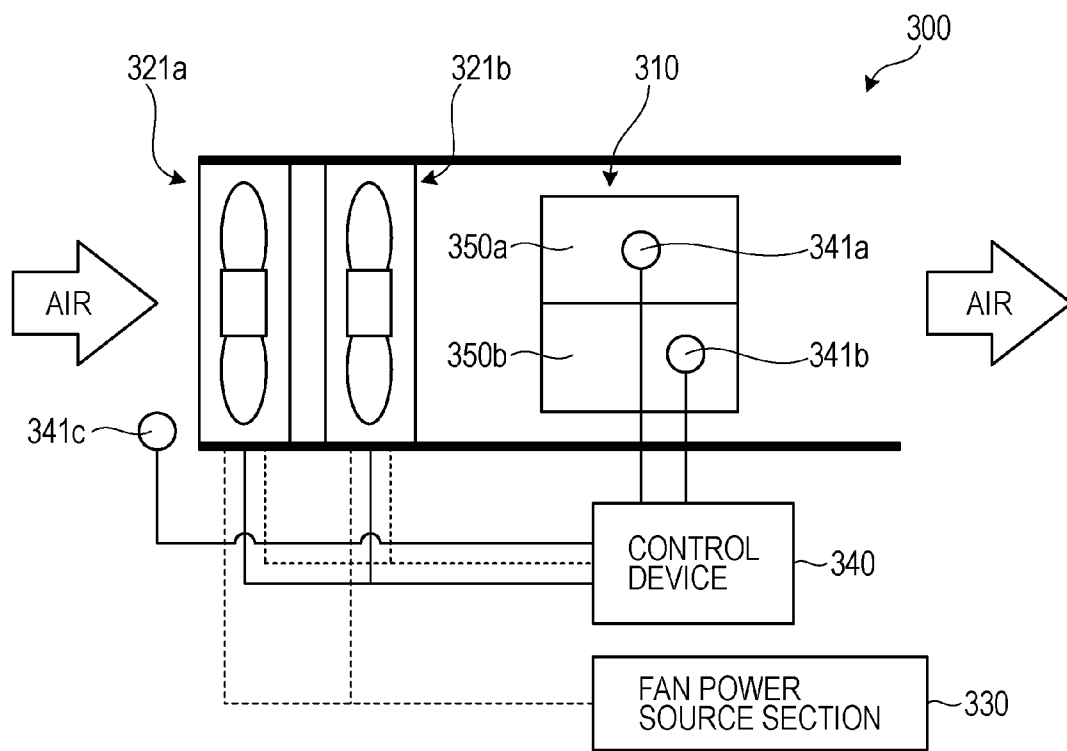

FIG. 27

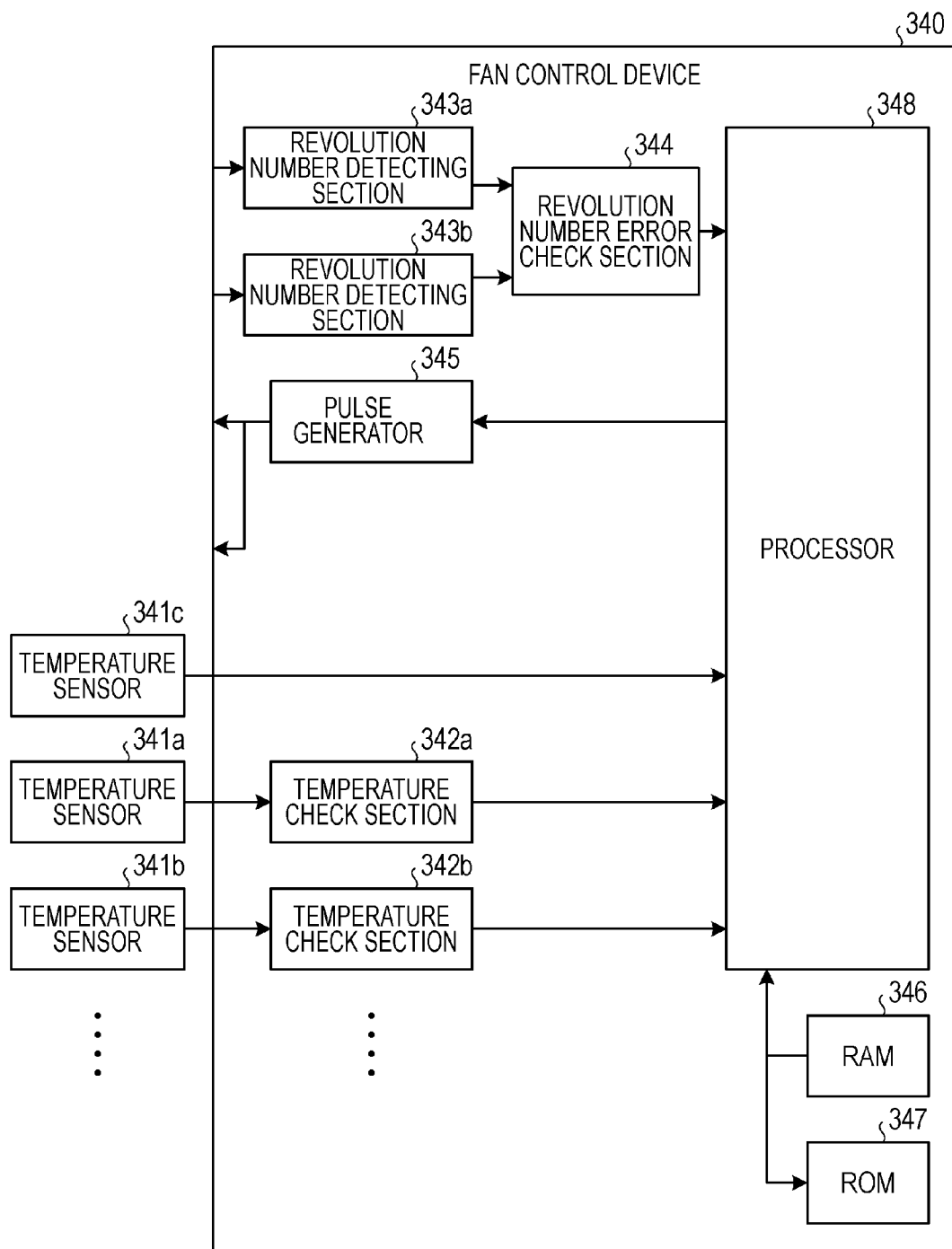

FIG. 28

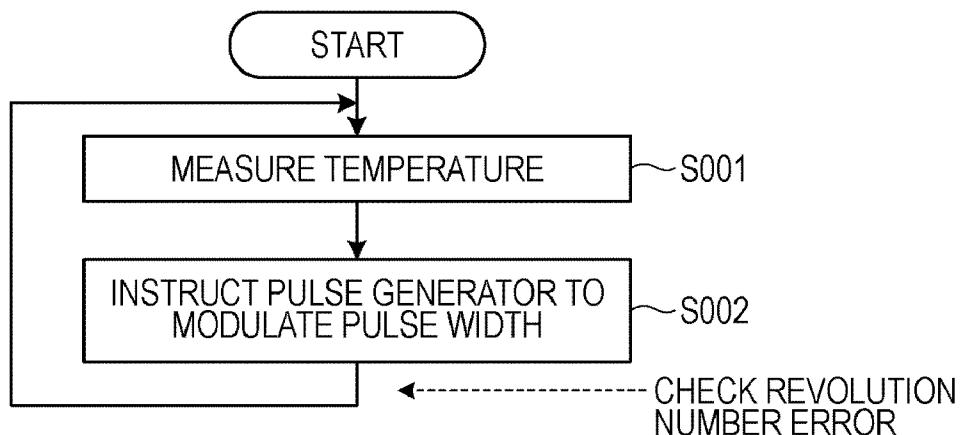
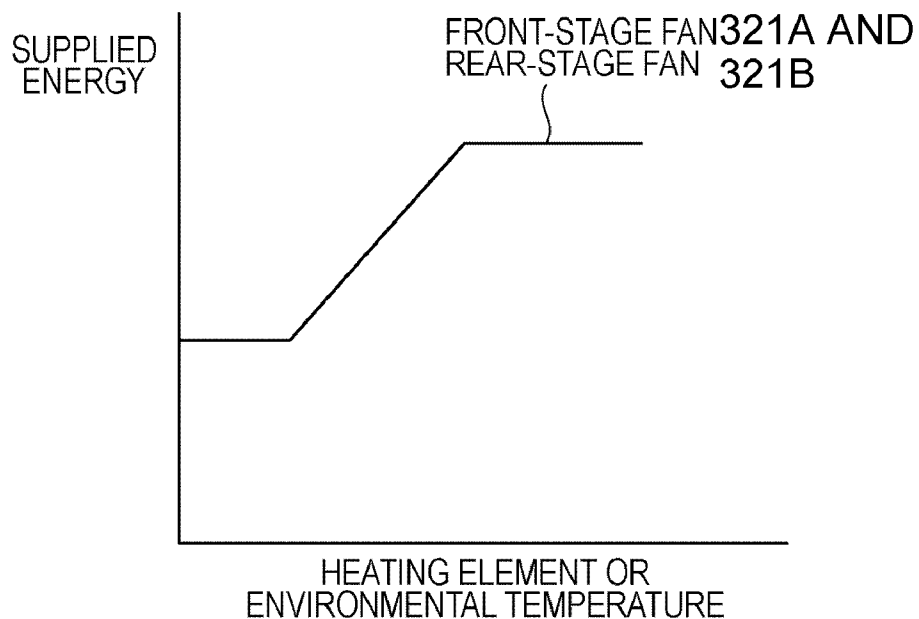

FIG. 29



FAN CONTROL APPARATUS AND FAN CONTROL METHOD

CROSS-REFERENCE TO RELATED APPLICATION

[0001] This application is based upon and claims the benefit of priority of the prior Japanese Patent Application No. 2009-123500, filed on May 21, 2009, the entire contents of which are incorporated herein by reference.

FIELD

[0002] The embodiments discussed herein are relates to a fan control apparatus and a fan control method.

BACKGROUND

[0003] In existing electronic equipment such as a server device, a PC (Personal Computer) and others, in some cases, fans that send air into equipment concerned to radiate heat in the equipment to the outside in order to avoid temperature rising in the equipment with heat generated from a processor or the like are mounted on the equipment.

[0004] In a fan, noise (whirring sounds) is generated owing to formation of air eddies in the vicinity of blades. Noise generated from a fan is increased with increasing an air flow rate at which the fan blows off air. Therefore, if it is intended to increase the number of revolutions (hereinafter, referred to as the revolution number) of the fan to increase the air flow rate, the noise will be increased accordingly. Specifically, it is known that noise from a fan is proportional to the fifth or sixth power of the number of axial rotations of the fan.

[0005] Recently, such a situation has been more and more frequently observed that electronic equipment is installed not only in a specific place such as a computer room but also in a general office and hence consciousness of noise reduction is now being raised. Therefore, how the noise generated from a fan is reduced is one of important problems to be solved.

[0006] As a method of reducing noise generated from a fan, a method of monitoring the temperature of a heating element and the environmental temperature around the heating element and changing the revolution number of the fan concerned in accordance with the temperatures so monitored to control the noise from the fan so as not to increase more than needed is known. The revolution number of the fan is controlled by modulating the pulse width (the PWM value) of a voltage or PWM (Pulse Width Modulation) signal to control energy to be supplied to the motor of the fan.

[0007] On the hand, nowadays, in some cases, a space for an air passage in equipment is reduced with size and thickness reduction of the electronic equipment and such a case in which only a small fan is allowed to be installed is now being more frequently observed. In addition, a heating value of electronic equipment is more and more increased every year as processing speed and performance of electronic equipment get higher. Thus, such a countermeasure is taken that a plurality of fans is superposed on one another in a multi-stage form so as to sufficiently cool the inside of electronic equipment even when installation of only small-sized fans is allowed.

[0008] In this connection, an example in which a plurality of fans is superposed on one another in a multi-stage form is illustrated in FIG. 26. FIG. 26 illustrates an example of electronic equipment in which two fans are disposed in series.

[0009] As illustrated in FIG. 26, two fans 321a and 321b are installed in series in an air passage 310 of electronic equipment 300. The electronic equipment 300 includes a fan power source section 330 and a control section 340. The fan power source section 330 is a power source for supplying power to motors not illustrated which are built in the fans 321a and 321b. The control section 340 controls amounts of energy supplied to the fans 321a and 321b on the basis of temperatures of heating elements 350a and 350b detected using temperature sensors 341a and 341b and an environmental temperature detected using a temperature sensor 341c. Next, a specific configuration of the control section 340 will be illustrated. FIG. 27 is a block diagram illustrating a configuration of the existing control section 340.

[0010] As illustrated in FIG. 27, the control section 340 includes the temperature sensors 341a to 341c, temperature check sections 342a and 342b, revolution number detecting sections 343a and 343b, a revolution number error check section 344 and a pulse generator 345. The control section 340 also includes a RAM (Random Access Memory) 346, a ROM (Read Only Memory) 347 and a processor 348.

[0011] The temperature sensors 341a and 341b are attached to the heating elements 350a and 350b in the electronic equipment 300 to detect the temperatures of the heating elements 350a and 350b. The temperature sensor 341c is installed outside of the electronic equipment 300 to detect the environmental temperature around the fan 321a. The temperature check sections 342a and 342b check to see to which extent the temperatures of the heating elements 350a and 350b detected using the temperature sensors 341a and 341b vary from a target temperature and notify the processor 348 of results of check in the form of predetermined variables.

[0012] The revolution number detecting sections 343a and 343b detect the revolution numbers of the fans 321a and 321b. The revolution number check section 344 checks to see whether the fans 321a and 321b normally rotate on the basis of the revolution numbers of the fans 321a and 321b detected using the revolution number detecting sections 343a and 343b and notifies the processor 348 of a result of check. The pulse generator 345 inputs pulses for controlling the revolution numbers of the fans 321a and 321b into the fans 321a and 321b in pulse widths in accordance with an instruction from the processor 348.

[0013] The ROM 347 stores therein a table indicating predetermined variables corresponding to temperatures of the heating elements 350a and 350b and PWM values of pulses to be input into the heating elements 350a and 350b in one-to-one correspondence and a table indicating environmental temperatures and the PWM values in one-to-one correspondence. The processor 348 determines the pulse widths of pulses to be output to the fans 321a and 321b on the basis of the predetermined variables sent from the temperature check sections 342a and 342b and the environmental temperature detected using the temperature sensor 341c. A specific example thereof is as illustrated in FIG. 27. FIG. 28 is a flowchart illustrating an example of procedures of processing executed using the existing processor 348.

[0014] As illustrated in FIG. 28, first, the processor 348 performs temperature measurement (step S001). That is, the processor 348 acquires predetermined variables corresponding to the temperatures of the heating elements 350a and 350b detected using the temperature sensors 341a and 341b from the temperature check sections 342a and 342b. The processor

348 also acquires the environmental temperature detected using the temperature sensor **341c**.

[0015] Next, the processor **348** instructs the pulse generator **345** to modulate the pulse widths on the basis of results of measurement of the environmental temperature and the temperatures of the heating elements **350a** and **350b** (step **S002**). Specifically, first, the processor **348** determines PWM values corresponding to the predetermined variables acquired from the temperature check sections **342a** and **342b** or the environmental temperature acquired from the temperature sensor **341c** on the basis of the tables stored in the ROM **347**. Then, the processor **348** instructs the pulse generator **345** to modulate widths of pulses to be input into the fans **321a** and **321b** to have the PWM values so determined (step **S002**).

[0016] The pulse generator **345** then inputs pulses whose widths have been modulated to have the PWM values as instructed from the processor **348**. As a result, the revolution numbers of the fans **321a** and **321b** are changed to the revolution numbers conforming to the environmental temperature and the temperatures of the heating elements **350a** and **350b**. As described above, the existing processor **348** determines the pulse widths on the basis of the environmental temperature and the temperatures of the heating elements **350a** and **350b**. Incidentally, the existing control section **340** detects the revolution numbers of the fans **321a** and **321b** using the revolution number detecting sections **343a** and **343b** to check on errors in the revolution numbers. Specifically, the processor **348** sends an error notification that the fans **321a** and **321b** are now in stopped states to the electronic equipment **300** on the basis of results of revolution number error check acquired from the revolution number error check section **344**.

[0017] Incidentally, hitherto, the control section **340** has controlled the fans **321a** and **321b** in the same manner. In the following, the fan **321a** which is situated on the side of taking air into the equipment from the outside will be referred to as a front-stage fan **321a** and the fan **321b** which is situated on the side of sending the air into the electronic equipment **300** will be referred to as a rear-stage fan **321b**.

[0018] The processor **348** determines a pulse width of a pulse which is commonly input into the front-stage fan **321a** and the rear-stage fan **321b** at step **S002** in FIG. **28** and notifies the pulse generator **345** of the pulse width. As a result, hitherto, energy of the same amount has been usually supplied from the pulse generator **345** to the front-stage fan **321a** and the rear-stage fan **321b** as illustrated in FIG. **29**.

[0019] However, in the case that the fans **321a** and **321b** are superposed on each other in a multi-stage form, the work amount with which the rear-stage fan **321b** blows off air is reduced influenced by an air current generated from the front-stage fan **321a**. Therefore, if the amount of energy supplied to the front-stage fan **321a** is the same as that supplied to the rear-stage fan **321b**, the rear-stage fan **321b** will run idle and hence the revolution number of the rear-stage fan **321b** will be increased. Noise is generated greatly influenced by the operation of the fan of the largest revolution number and hence an increase in revolution number of the rear-stage fan **321b** will be a major factor to cause an increase in noise.

[0020] In this connection, a technique for, example, making the revolution number of the front-stage fan **321a** different from that of the rear-stage fan **321b** is known. Specifically, in the above mentioned technique, the pulse width of a pulse input into the rear-stage fan **321b** is controlled to become shorter than that of a pulse input into the front-stage fan **321a**. In the above mentioned case, if the revolution number of the

rear-stage fan **321b** is reduced, an air flow rate (needed air flow rate) needed to cool heating elements may not be possibly obtained. Therefore, it may become needed to increase the revolution number of the front-stage fan **321a** more than that needed when the energy of the same amount is applied to each of the fans **321a** and **321b**. An example of the above mentioned technique is disclosed, for example, in Japanese Laid-open Patent Publication No. 2004-179186.

[0021] However, in the above mentioned known technique, the revolution number of the front-stage fan **321a** is simply increased with no consideration of the system impedance characteristic of the electronic equipment **300**, so that the noise may be rather increased as compared with a case in which the energy of the same amount is applied to each of the fans **321a** and **321b**. The system impedance characteristic is a pressure loss determined from a density at which components constituting the electronic equipment **300** are packaged and the shape of an air passage therein and is a characteristic intrinsic to the electronic equipment **300** concerned.

[0022] That is, the noise generated from the fans **321a** and **321b** varies depending on the characteristics and the shapes of these fans **321a** and **321b** and also depending on the configuration of the electronic equipment **300** concerned on which the fans **321a** and **321b** are mounted and locations of the fans **321a** and **321b** in the electronic equipment **300** concerned. Therefore, if the revolution number of the front-stage fan **321a** is simply increased, the noise generated from the front-stage fan **321a** may be possibly increased more than the noise generated from the rear-stage fan **321b** when the energy of the same amount is applied to each of the fans **321a** and **321b** depending on the locations of the fans.

SUMMARY

[0023] According to an aspect of the embodiments, a fan controlling apparatus for controlling a plurality of fans which are tandemly arranged in ventilation direction of a chamber to control a temperature of a hot generating object placed in the chamber, the apparatus includes a memory for storing data of the rotational speed each of fans in relation to the temperature of the heat generating object, and, a controller for controlling the rotational speed of each of the fans respectively in dependence on the temperature of the heat generating object in reference to the data stored in the memory.

[0024] The object and advantages of the invention will be realized and attained by means of the elements and combinations particularly pointed out in the claims. It is to be understood that both the foregoing general description and the following detailed description are exemplary and explanatory and are not restrictive of the invention, as claimed.

BRIEF DESCRIPTION OF DRAWINGS

[0025] FIG. **1** is a block diagram illustrating a configuration of a fan control device according to an embodiment 1;

[0026] FIG. **2** is a diagram illustrating a configuration of electronic equipment according to an embodiment 2;

[0027] FIG. **3** is a block diagram illustrating a configuration of a fan control device according to the embodiment 2;

[0028] FIG. **4** is a block diagram illustrating specific configurations of a processor and a ROM according to the embodiment 2;

[0029] FIG. **5** is a diagram illustrating an example of an equipment state management table;

[0030] FIG. 6 is a diagram illustrating information stored in a control data storage section according to the embodiment 2;

[0031] FIG. 7A is a diagram illustrating an example of a heating-element-temperature-based PWM value determination table;

[0032] FIG. 7B is a diagram illustrating an example of an environmental-temperature-based PWM value determination table;

[0033] FIG. 8 is a diagram explaining a difference between energy supplied to a front-stage fan and energy supplied to a rear-stage fan;

[0034] FIG. 9 is a diagram illustrating a specific configuration of a database preparing section according to the embodiment 2;

[0035] FIG. 10 is a flowchart illustrating an example of procedures of preparing the heating-element-temperature-based PWM value determination table and the environmental-temperature-based PWM value determination table;

[0036] FIG. 11 is a flowchart illustrating an example of procedures of processing executed using the processor according to the embodiment 2;

[0037] FIG. 12 is a diagram illustrating effects brought about by the embodiment 2;

[0038] FIG. 13 is a diagram illustrating examples of measurement conditions involving experiments for validation;

[0039] FIG. 14A is a diagram illustrating data indicative of a result of measurement of the front-stage revolution number, the rear-stage revolution number and the device noise performed under a measurement condition A;

[0040] FIG. 14B is a diagram illustrating data indicative of a result of measurement of the front-stage revolution number, the rear-stage revolution number and the consumption power performed under the measurement condition A;

[0041] FIG. 14C is a diagram illustrating data indicative of a result of analysis of frequencies of the device noise performed under the measurement condition A;

[0042] FIG. 15A is a diagram illustrating a result of measurement performed under a condition A-1;

[0043] FIG. 15B is a diagram illustrating a result of measurement performed under a condition A-2;

[0044] FIG. 15C is a diagram illustrating a result of measurement performed under a condition A-3;

[0045] FIG. 16A is a diagram illustrating data indicative of a result of measurement of the front-stage average revolution number, the rear-stage average revolution number and the device noise performed under conditions B-1 and B-2;

[0046] FIG. 16B is a diagram illustrating data indicative of a result of measurement of the front-stage average revolution number, the rear-stage average revolution number and the consumption power performed under the conditions B-1 and B-2;

[0047] FIG. 16C is a diagram illustrating data indicative of a result of analysis of frequencies of the device noise performed under the conditions B1 and B2;

[0048] FIG. 17A is a diagram illustrating a result of measurement performed under the condition B-1;

[0049] FIG. 17B is a diagram illustrating a result of measurement performed under the condition B-2;

[0050] FIG. 18A is a diagram illustrating data indicative of a result of measurement of the front-stage average revolution number, the rear-stage average revolution number and the device noise performed under conditions B-3 and B-4;

[0051] FIG. 18B is a diagram illustrating data indicative of a result of measurement of the front-stage average revolution

number, the rear-stage average revolution number and the consumption power performed under the conditions B-3 and B-4;

[0052] FIG. 18C is a diagram illustrating data indicative of a result of analysis of frequencies of the device noise performed under the conditions B3 and B4;

[0053] FIG. 19A is a diagram illustrating a result of measurement performed under the condition B-3;

[0054] FIG. 19B is a diagram illustrating a result of measurement performed under the condition B-4;

[0055] FIG. 20 is a functional block diagram illustrating an example of a computer for executing a fan control program;

[0056] FIG. 21 is a block diagram illustrating a configuration of a fan control device according to an embodiment 3;

[0057] FIG. 22 is a block diagram illustrating specific configurations of a processor and a ROM according to the embodiment 3;

[0058] FIG. 23 is a diagram illustrating information stored in a control data storage section according to the embodiment 3;

[0059] FIG. 24 is a diagram illustrating an example of a rear-stage PWN value change table;

[0060] FIG. 25 is a flowchart illustrating an example of procedures of processing executed using the processor according to the embodiment 3;

[0061] FIG. 26 is a diagram illustrating an example of electronic equipment in which two fans are disposed in series;

[0062] FIG. 27 is a block diagram illustrating a configuration of an existing control section;

[0063] FIG. 28 is a flowchart illustrating an example of procedures of processing executed using an existing processor; and

[0064] FIG. 29 is a diagram illustrating that the amount of energy supplied to a front-stage fan is the same as that supplied to a rear-stage fan.

DESCRIPTION OF EMBODIMENTS

[0065] Next, preferred embodiments of a fan control device, a fan control method and a fan control program disclosed in the present application will be described in detail with reference to the accompanying drawings.

Embodiment 1

[0066] A fan control device according to an embodiment 1 will be described. The fan control device according to the embodiment 1 is a control device that controls operational conditions of a plurality of fans disposed in series relative to an air passage formed in equipment.

[0067] The plurality of fans blow off air to heating elements disposed in the equipment to forcibly air-cool the heating elements. The fan control device controls the revolution number of each of the plurality of fans. FIG. 1 is a block diagram illustrating a configuration of the fan control device according to the embodiment 1.

[0068] As illustrated in FIG. 1, a fan control device 500 according to the embodiment 1 includes a temperature detecting section 510 and a control section 520. The temperature detecting section 510 detects the temperature of each heating element. The control section 520 then controls the revolution numbers of the fans such that an air flow rate needed for cooling the heating elements is obtained in a state that the revolution numbers of the fans coincide with each other on the

basis of the temperatures of the heating elements detected using the temperature detecting section 510.

[0069] Specifically, the control section 520 according to the embodiment 1 controls the revolution numbers of the fans such that the needed air flow rate (the cooling air flow rate) needed to cool the heating elements obtained from the temperatures of the heating elements, the pipeline resistance in the equipment and the total static pressure-air flow rate characteristic of the fans in a state in which a difference in revolution number between the fans is in a predetermined tolerance is acquired and the difference in revolution number between the fans is set in the predetermined tolerance. By controlling the revolution number of each fan in the above mentioned manner, the respective fans rotate in a state in which the difference in revolution number between the fans is maintained in the predetermined tolerance, that is, rotate in a state in which the revolution numbers of the respective fans coincide with each other in the predetermined tolerance to send air to the heating elements at a needed air flow rate determined in accordance with the current temperature of each heating element.

[0070] As described above, the fan control device 500 according to the embodiment 1 controls so as to maintain the difference in revolution number between the fans in the predetermined tolerance, desirably, so as to control the revolution numbers of the fans to coincide with each other. Therefore, such a situation may be avoided that the total noise generated from the fans is increased owing to surplus noise generated from a fan of the largest revolution number.

[0071] The needed air flow rate attained according to the embodiment 1 is obtained by taking the temperatures of the heating elements, the pipeline resistance in the equipment and the total static pressure-air flow rate characteristic of the fans obtained in a state in which the difference in revolution number between the fans is maintained in the predetermined tolerance into consideration. Therefore, according to the embodiment 1, the air flow rate suited to cool the heating elements may be obtained in a state in which the difference in revolution number between the fans is maintained in the predetermined tolerance regardless of the configuration of the equipment and the locations of the fans in the equipment.

[0072] Therefore, according to the embodiment 1, it may be possible to reduce the noise generated from the plurality of fans while obtaining the air flow rate needed for cooling the heating elements in the equipment using the plurality of fans.

Embodiment 2

[0073] Next, a fan control device according to an embodiment 2 will be described. The fan control device according to the embodiment 2 is configured to control the revolution numbers of two fans installed in electronic equipment such as a rack-mounted type server device, a general PC and others. First, a configuration of electronic equipment in which the fan control device according to the embodiment 2 is installed will be described. FIG. 2 is a diagram illustrating a configuration of the electronic equipment according to the embodiment 2.

[0074] As illustrated in FIG. 2, electronic equipment 50 according to the embodiment 2 includes two fans 3a, 3b and heating elements 52a and 52b such as processors installed in an air passage 51 formed in the electronic equipment 50.

[0075] The fans 3a and 3b are axial fans of the same shape and characteristic. The fans 3a and 3b are disposed in series relative to the air passage 51 and generate air currents flowing from the fan 3a toward the fan 3b to forcibly air-cool the

heating elements 52a and 52b disposed downstream of the air currents. In the following, of the fans 3a and 3b, the fan 3a for sucking air from the outside of the electronic equipment 50 will be referred to as a front-stage fan and the fan 3b for distributing the air which has been sucked using the front-stage fan 3a into the electronic equipment 50 will be referred to as a rear-stage fan.

[0076] The electronic equipment 50 also includes a fan control device 1 and a fan power source section 2 installed outside of the air passage 51. The fan power source section 2 is a power source for supplying power to motors not shown which are built in the fans 3a and 3b. That is, when the power is supplied from the fan power source section 2, the motors of the fans 3a and 3b rotate and blades attached to the motors rotate in cooperation with the rotation of the motors, and hence the fans 3a and 3b generate air currents flowing toward the heating elements 52a and 52b.

[0077] The fan control device 1 detects the temperatures of the heating elements 52a and 52b and the temperature (the environmental temperature) outside of the electronic equipment 50 using temperature sensors 11a to 11c. The fan control device 1 then controls the revolution numbers of the fans 3a and 3b so as to obtain an air flow rate needed for cooling the heating elements 52a and 52b in a state in which the difference in revolution number between the fans 3a and 3b is maintained in the predetermined tolerance on the basis of the temperatures detected using the temperature sensors 11a to 11c. Next, a specific configuration of the fan control device 1 described above will be illustrated. FIG. 3 is a block diagram illustrating a configuration of the fan control device according to the embodiment 2.

[0078] As illustrated in FIG. 3, the fan control device 1 includes the temperature sensors 11a to 11c, temperature check sections 12a and 12b, revolution number detecting sections 13a and 13b, a revolution number error check section 14 and pulse generators 15a and 15b. The fan control device 1 also includes a RAM 16, a ROM 17 and a processor 18.

[0079] The temperature sensors 11a and 11b are attached to the heating elements 52a and 52b and detect the temperatures of the heating elements 52a and 52b. The temperature sensor 11c is disposed outside of the electronic equipment 50 and detects the environmental temperature around the front-stage fan 3a. The temperature sensors 12a and 12b check to see to which extent the temperatures of the heating elements 52a and 52b detected using the temperature sensors 11a and 11b are varied from a target temperature and notify the processor 18 of results of check in the form of predetermined variables.

[0080] The revolution number detecting sections 13a and 13b are, for example, pulse counters and respectively detect the revolution numbers of the fans 3a and 3b. The revolution number error check section 14 checks to see whether the fans 3a and 3b normally rotate on the basis of the revolution numbers of the fans 3a and 3b detected using the revolution number detecting sections 13a and 13b and notifies the processor 18 of a result of check.

[0081] The pulse generators 15a and 15b input pulses used to control the revolution numbers of the fans 3a and 3b in pulse widths (PWM values) as instructed from the processor 18 into the fans 3a and 3b. Specifically, the pulse generator 15a inputs a pulse of a PWM value as instructed from the processor 18 into the front-stage fan 3a. The pulse generator 15b inputs a pulse of a PWM value as instructed from the processor 18 into the rear-stage fan 3b. As a result, the fans 3a

and **3b** rotate with the revolution numbers conforming to the pulse widths of the pulses input from the pulse generators **15a** and **15b**.

[0082] The ROM **17** stores therein various pieces of data needed for processing executed using the processor **18**. The processor **18** determines PWM values of pulses to be input into the front-stage fan **3a** and the rear-stage fan **3b** on the basis of the temperatures detected using the temperature sensors **11a** to **11c**. Next, specific configurations of the processor **18** and the ROM **17** according to the embodiment 2 will be described. FIG. **4** is a block diagram illustrating the specific configurations of the processor **18** and the ROM **17** according to the embodiment 2.

[0083] As illustrated in FIG. **4**, the ROM **17** includes an equipment state storage section **171** and a control data storage section **172**. The equipment state storage section **171** stores an equipment state management table. The equipment state management table is a table used to specify the system impedance (the pipeline resistance) corresponding to the current configuration of the electronic equipment **50**. FIG. **5** illustrates an example of the equipment state management table **61**.

[0084] As illustrated in FIG. **5**, in equipment state management table **61**, system impedances and one equipment state specification flag are stored such that the flag corresponds to one of the impedances. In the example illustrated in the drawing, the impedance is a pressure loss determined from a density rate at which the respective components of the electronic equipment **50** are packaged and the shape of an air passage in the equipment. In the equipment state management table **61** according to the embodiment 2, a plurality of impedances measured by changing the configuration of the electronic equipment **50** are stored and the equipment state specification flag is set for a system impedance corresponding to the current configuration of the electronic equipment **50**.

[0085] For example, in the equipment state management table **61** illustrated in FIG. **5**, system impedances A to C respectively measured by changing the configuration of the electronic equipment **50** are stored and the electronic state specification flag is set for the system impedance A. That is, the equipment state management table **61** illustrated in FIG. **5** indicates that the system impedance corresponding to the current configuration of the electronic equipment **50** is "A". In the case that the configuration of the electronic equipment has been changed, the equipment state management table **61** is manually updated by a user of the electronic equipment **50**. Owing to the above mentioned operation, even when the configuration of the electronic equipment **50** has been changed, the system impedance corresponding to a fresh configuration of the electronic equipment **50** may be specified.

[0086] The control data storage section **172** stores a heating-element-temperature-based PWM value determination table and an environmental-temperature-based PWM value determination table. The heating-element-temperature-based PWM value determination table is a table used to specify PWM values of pulses to be input into the fans **3a** and **3b** on the basis of the temperatures of the heating elements **52a** and **52b**. The environmental-temperature-based PWM value determination table is a table used to specify PWM values of pulses to be input into the fans **3a** and **3b** on the basis of the environmental temperature. Next, these pieces of information stored in the control data storage section **172** will be specifically

described. FIG. **6** is a diagram for explaining information stored in the control data storage section **172** according to the embodiment 2.

[0087] As illustrated in FIG. **6**, the control data storage section **172** stores heating-element-temperature-based PWM value determination tables **71a** to **71c** and environmental-temperature-based PWM value determination tables **72a** to **72c** in one-to-one correspondence with the plurality of system impedances A to C. Specifically, the control data storage section **172** stores the heating-element-temperature-based PWM value determination table **71a** and the environmental-temperature-based PWM value determination table **72a** corresponding to the system impedance A. The control data storage section **172** also stores the heating-element-temperature-based PWM value determination table **71b** and the environmental-temperature-based PWM value determination table **72b** corresponding to the system impedance B. The control data storage section **172** further stores the heating-element-temperature-based PWM value determination table **71c** and the environmental-temperature-based PWM value determination table **72c** corresponding to the system impedance C.

[0088] FIG. **7A** illustrates an example of the heating-element-temperature-based PWM value determination table **71a**. As illustrated in FIG. **7A**, in the heating-element-temperature-based PWM value determination table **71a**, heating element temperatures, common revolution numbers, front-stage PWM values and rear-stage PWM values are stored in one-to-one correspondence. For example, as illustrated in FIG. **7A**, in the heating-element-temperature-based PWM value determination table **71a**, the common revolution number "aaa", the front-stage PWM value "Nfa" and the rear-stage PWM value "Nra" are stored corresponding to the heating element temperature "A". The heating element temperatures are stored in the form of predetermined variables output from the temperature check sections **12a** and **12b** in accordance with the temperatures of the heating elements **52a** and **52b**.

[0089] The common revolution number (min^{-1}) is a revolution number commonly set for the fans **3a** and **3b** in the case that an air flow rate needed for cooling the heating elements **52a** and **52b** is obtained in a state in which a difference in revolution number between the fans **3a** and **3b** is maintained in a predetermined tolerance. In the example illustrated in FIG. **7A**, the needed air flow rate stored in the heating-element-temperature-based PWM value determination tables **71a** to **71c** is an air flow rate determined in accordance with temperatures of the heating elements **52a** and **52b**, a system impedance in the electronic equipment **50** and a total PQ characteristic (a static pressure-air flow rate characteristic) of the fans **3a** and **3b** obtained in a state in which the difference in revolution number between the fans **3a** and **3b** is maintained in the predetermined tolerance. Incidentally, the system impedance, the PQ characteristic and the common revolution number are obtained from thermal hydraulic simulation and measurement performed on the basis of measurement of temperatures of the heating elements **52a** and **52b**. Details thereof will be described later.

[0090] In this embodiment, the "predetermined tolerance" is a range in which the difference in revolution number between the front-stage fan **3a** and the rear-stage fan **3b** is less than 10%. That is, ideally, the noise generated from these fans **3a** and **3b** may be minimized by controlling the revolution number of the front-stage fan **3a** to coincide with that of the

rear-stage fan **3b**. However, even in the case that the revolution number of the front-stage fan **3a** is slightly different from that of the rear-stage fan **3b**, any problem will not cause as long as an error in noise caused by the slight difference of the revolution number of the front-stage fan from that of the rear-stage fan is so small that it is not recognized with human's ears. In the case that the difference in revolution number between the front-stage fan **3a** and the rear-stage fan **3b** is 10%, the noise generated from these fans **3a** and **3b** is larger than the noise generated when the revolution numbers of the front-stage blower **3a** and the rear-stage blower **3b** are controlled to coincide with each other by about 3 dB. Basically, it is said that the error of 3 dB is not recognized with human's ears. Therefore, in this embodiment, the "predetermined tolerance" is defined as a range in which the difference in revolution number between the front-stage fan **3a** and the rear-stage fan **3b** is less than 10%.

[0091] However, some persons may recognize the error of 3 dB with their ears, so that, more preferably, the difference in revolution number between the front-stage blower **3a** and the rear-stage blower **3b** is set to be less than 5%. With the difference in revolution number between the front-stage fan **3a** and the rear-stage fan **3b** of less than 5%, the noise generated from the front-stage fan **3a** and the rear-stage fan **3b** becomes larger than the noise generated when the revolution numbers of the front-stage fan **3a** and the rear-stage fan **3b** are controlled to coincide with each other by about 1 dB. As described above, a noise reduction effect which is equivalent to that attained when the revolution numbers of the front-stage fan **3a** and the rear-stage fan **3b** are controlled to coincide with each other may be more obtained by setting the "predetermined tolerance" to a range in which the difference in revolution number between the front-stage fan **3a** and the rear-stage fan **3b** is less than 5%.

[0092] The front-stage PWM value (s) is a PWM value of a pulse to be input into the front-stage fan **3a** in order to rotate the front-stage fan **3a** with a common revolution number. The rear-stage PWM value (s) is a PWM value of a pulse to be input into the rear-stage fan **3b** in order to rotate the rear-stage fan **3b** with the common revolution number. That is, for example, when the heating element temperature is "A", the pulse of the front-stage PWM value "Nfa" is input into the front-stage fan **3a** and the pulse of the rear-stage PWM value "Nra" corresponding to the front-stage PWM value "Nfa" is input into the rear-stage fan **3b**, thereby rotating the fans **3a** and **3b** with the common revolution number "aaa". These front-stage and rear-stage PWM values may be obtained from measurement performed in advance.

[0093] FIG. 7B illustrates an example of the environmental-temperature-based PWM value determination table **72a**. As illustrated in FIG. 7B, environmental temperatures, common revolution numbers, front-stage PWM values and rear-stage PWM values are stored in the environmental-temperature-based PWM value determination table **72a** in one-to-one correspondence. For example, as illustrated in FIG. 7B, the common revolution number "fff", the front-stage PWM value "Nff" and the rear-stage PWM value "Nrf" are stored in the environmental-temperature-based PWM value determination table **72a** corresponding to the heating element temperature "F". In the example illustrated in the drawing, the environmental temperature is a temperature detected using the temperature sensor **11c**.

[0094] The common revolution number is a revolution number which is commonly set for the fans **3a** and **3b** in order

to obtain an air flow rate needed to cool the heating elements **52a** and **52b** in a state in which the difference in revolution number between the fans **3a** and **3b** is maintained in the predetermined tolerance as in the case in the heating-element-temperature-based PWM value determination tables **71a** to **71c**. In the example illustrated in the drawing, the needed air flow rate stored in the environmental-temperature-based PWM value determination tables **72a** to **72c** is an air flow rate which is obtained in accordance with an environmental temperature, a system impedance in the electronic equipment **50** and a total PQ characteristic of the fans **3a** and **3b** obtained when a difference in revolution number between the fans **3a** and **3b** is in the predetermined tolerance.

[0095] The front-stage PWM value and the rear-stage PWM value are PWM values of pulses to be input into the front-stage fan **3a** and the rear-stage fan **3b** in order to rotate the front-stage fan **3a** and the rear-stage fan **3b** with a common revolution number as in the case in the heating-element-temperature-based PWM value determination tables **71a** to **71c**. That is, for example, with the heating element temperature "G", the pulse of the front-stage PWM value "Nfg" is input into the front-stage fan **3a** and the pulse of the rear-stage PWM value "Nrg" corresponding to the front-stage PWM value "Nfg" is input into the rear-stage fan **3b** to rotate the fans **3a** and **3b** with the common revolution number "ggg".

[0096] As described above, the control data storage section **172** corresponds to control data storage means and stores input values of pulses to be input into the fans **3a** and **3b** per temperature in order to obtain the air flow rate needed to cool the heating elements in a state in which the difference in revolution number between the fans **3a** and **3b** is maintained in the predetermined tolerance. In addition, the control data storage section **172** corresponds to control data storage means and stores input values of pulses to be input into the front-stage fan **3a** and the rear-stage fan **3b** per system impedance.

[0097] As illustrated in FIG. 4, the processor **18** includes an error processing section **181**, a temperature information acquiring section **182**, an input value determining section **183** and database preparing section **184**.

[0098] The error processing section **181** executes an error notifying process on the basis of information acquired from the revolution number error check section **14**. The error processing section **181** acquires a result of check indicating that the front-stage fan **3a** or the rear-stage fan **3b** is now in a stopped state from the revolution number error check section **14**. The error processing section **181** then sends an error notification that the fan **3a** or **3b** is in the stopped state to the electronic equipment **50** on the basis of the result of check acquired. As a result, an error message that the fan **3a** or **3b** is now in the stopped state is displayed on a display not illustrated of the electronic equipment **50**.

[0099] The temperature information acquiring section **182** acquires predetermined variables corresponding to temperatures of the heating elements **52a** and **52b** from the temperature check sections **12a** and **12b** as data indicative of the heating element temperatures. The temperature information acquiring section **182** also acquires the environmental temperature from the temperature sensor **12c**. As described above, the temperature sensors **11a** and **11b**, the temperature check sections **12a** and **12b** and the temperature information acquiring section **182** functions as an example of temperature detecting means for detecting the temperatures of the heating elements **52a** and **52b** installed in the electronic equipment **50**. The temperature sensor **11c** and the temperature informa-

tion acquiring section 182 also function as an example of temperature detecting means for detecting the temperature outside of the electronic equipment 50.

[0100] The input value determining section 183 specifies a system impedance corresponding to the current configuration of the electronic equipment 50 with reference to data stored in the equipment state storage section 171. In addition, the input value determining section 183 acquires the respective PWM values of pulses to be input into the fans 3a and 3b from the control data storage section 172 on the basis of the specified system impedance and the heating element temperatures or the environmental temperature acquired from the temperature information acquiring section 182.

[0101] Specifically, the input value determining section 183 acquires a front-stage PWM value and a rear-stage PWM value corresponding to a combination of the specified system impedance with temperature information of the heating elements 52a and 52b acquired from the temperature information acquiring section 182 from the heating-element-temperature-based PWM value determination tables 71a to 71c. In addition, the input value determining section 183 acquires a front-stage PWM value and a rear-stage PWM value corresponding to a combination of the specified system impedance with environmental temperature information acquired from the temperature information acquiring section 182 from the environmental-temperature-based PWM value determination tables 72a to 72c.

[0102] For example, in the case that the specified system impedance is "A" and the heating element temperature acquired from the temperature information acquiring section 182 is "C", the input value determining section 183 acquires the front-stage PWM value "Nfc" and the rear-stage PWM value "Nrc" from the heating-element-temperature-based PWM value determination table 71a as illustrated in FIG. 7A.

[0103] The input value determining section 183 then instructs the pulse generator 15a to input the pulse of the acquired front-stage PWM value into the front-stage blower 3a and instructs the pulse generator 15b to input the pulse of the acquired rear-stage PWM value into the rear-stage blower 3b. In response to the instructions, the pulse generators 15a and 15b respectively input the pulses of the front-stage PWM value and rear-stage PWM value as instructed from the input value determining section 183 into the front-stage fan 3a and the rear-stage fan 3b. As a result, the front-stage fan 3a rotates with the revolution number conforming to the front-stage PWM value of the pulse input from the pulse generator 15a and the rear-stage fan 3b rotates with the revolution number conforming to the rear-stage PWM value of the pulse input from the pulse generator 15b.

[0104] Incidentally, as described above, the front-stage PWM value and the rear-stage PWM value are PWM values of pulses to be input into the fans 3a and 3b in order to obtain the needed air flow rate in a state in which the difference in revolution number between the fans 3a and 3b is maintained in the predetermined tolerance. Therefore, the difference in revolution number between the fans 3a and 3b is set in the predetermined tolerance by inputting pulses of the above mentioned front-stage and rear-stage PWM values into the respective fans 3a and 3b and air is fed into the equipment at the needed air flow rate conforming to the temperatures of the heating elements 52a and 52b.

[0105] As described above, in the fan control device 1 according to this embodiment, since the difference in revolution number between the fans 3a and 3b is maintained in the

predetermined tolerance, that is, the revolution numbers of the fans 3a and 3b are controlled to coincide with each other in the predetermined tolerance, such a situation may be avoided that surplus noise is generated from a fan of the largest revolution number to increase the total noise from the fans 3a and 3b.

[0106] In addition, the needed air flow rate according to this embodiment is determined by taking the temperatures of the heating elements 52a and 52b, the system impedance within the electronic equipment 50 and the total PQ characteristic of the fans 3a and 3b obtained when the difference in revolution number between the fans 3a and 3b is maintained in the predetermined tolerance into consideration. Therefore, according to this embodiment, the air flow rate suitable for cooling the heating elements 52a and 52b may be obtained in a state in which the revolution numbers of the fans 3a and 3b are controlled to coincide with each other in the predetermined tolerance regardless of the configuration of the electronic equipment 50 concerned and the locations of the fans 3a and 3b in the electronic equipment 50.

[0107] Incidentally, the input value determining section 183 determines different PWM values for the front-stage fan 3a and the rear-stage fan 3b and inputs pulses of the determined PWM values into the fans 3a and 3b via the pulse generators 15a and 15b. That is, as illustrated the graph 1001 in FIG. 8, different amounts of energy 1010 are supplied to the front-stage fan 3a and the rear-stage fan 3b. Specifically, the work amount of the rear-stage fan 3b is reduced influenced by the air currents generated from the front-stage fan 3a, so that the amount of energy supplied to the rear-stage fan 3b becomes smaller than that supplied to the front-stage fan 3a in the case that the revolution numbers of the fans 3a and 3b are controlled to coincide with each other.

[0108] In addition, in the case that the common revolution number obtained on the basis of the environmental temperature is larger than the common revolution number obtained on the basis of the heating element temperatures, the input value determining section 183 controls the revolutions numbers of the fans 3a and 3b by using the environmental-temperature-based PWM values. Specifically, the input value determining section 183 acquires common revolution numbers corresponding to the environmental temperature and the heating element temperatures acquired from the temperature information acquiring section respectively from the environmental-temperature-based PWM determination tables 72a to 72c and the heating-element-temperature-based PWM value determination tables 71a to 71c. The input value determining section 183 then compares a common revolution number obtained from the environmental temperature with a common revolution number obtained from the heating element temperatures, and in the case that the common revolution number obtained from the environmental temperature is larger than that obtained from the heating element temperatures, acquires the front-stage PWM value and the rear-stage PWM value corresponding to the environmental temperature concerned from the environmental-temperature-based PWM value determination tables 72a to 72c. As described above, the revolution numbers of the fans 3a and 3b are controlled on the basis of one of the environmental temperature and the heating element temperatures which will influence the heating elements 52a and 52b more greatly than another, so that the heating elements 52a and 52b may be maintained at more appropriate temperatures.

[0109] As described above, the input value determining section 183 and the equipment state storage section 171 function as an example of equipment state acquiring means for acquiring information on the system impedance within the electronic equipment 50. In addition, the input value determining section 183 and the pulse generators 15a and 15b function as an example of control means for controlling the revolution number of each fan on the basis of the temperature information acquired using the temperature information acquiring section 182 such that the air flow rate of air for cooling the heating elements 52a and 52b which is determined in accordance with the temperatures of the heating elements 52a and 52b, the system impedance within the electronic equipment 50 and the total static pressure-air flow rate characteristic of the fans 3a and 3b attained when the difference in revolution number between the fans 3a and 3b is maintained in the predetermined tolerance may be obtained and the difference in revolution number between the fans 3a and 3b may be set in the predetermined tolerance.

[0110] The database preparing section 184 executes various calculating processes in order to prepare the heating-element-temperature-based PWM value determination tables 71a to 71c and the environmental-temperature-based PWM value determination tables 72a to 72c before the fan control device is incorporated into the electronic equipment 50. Next, a specific configuration of the database preparing section 184 will be described. FIG. 9 is a block diagram illustrating a specific configuration of the database preparing section according to the embodiment 2.

[0111] As illustrated in FIG. 9, the database preparing section 184 includes a measured (already measured) system impedance information storage section 81, an equipment configuration information storage section 82, a system impedance information storage section 83, a temperature information storage section 84 and a temperature standard value information storage section 85. The database preparing section 184 also includes a needed air flow rate information storage section 86, a measured (already measured) PQ characteristic information storage section 87, a PQ characteristic information and revolution number information storage section 88 and a PWM value information storage section 89. The database preparing section 184 further includes a system impedance calculating section 91, a needed air flow rate calculating section 92, a fan PQ performance calculating section 93 and a fan PWM value calculating section 94.

[0112] The measured system impedance information storage section 81 stores measured system impedances of the electronic equipment 50. For example, the measured system impedance information storage section 81 stores system impedances corresponding to full configurations and popular configurations of the electronic equipment 50. The equipment configuration information storage section 82 stores a plurality of patterns of configurations of the electronic equipment 50. For example, the equipment configuration information storage section 82 stores information on the number of CPUs and the number of power sources which are built into the electronic equipment 50 per configuration of the electronic equipment 50. The system impedance information storage section 83 stores system impedances which are calculated per configuration of the electronic equipment 50 using the system impedance calculating section 91.

[0113] The temperature information storage section 84 stores the environmental temperature and the temperatures of the heating elements 5a and 52b. For example, the tempera-

ture information storage section 84 stores the temperatures of the CPUs and memories built into the electronic equipment as the temperatures of the heating element 52a and 52b. The temperature standard value information storage section 85 stores standard values of temperatures of the heating elements 52a and 52b. The needed air flow rate information storage section 86 stores the needed air flow rates calculated using the needed air flow rate calculating section 92.

[0114] The measured PQ characteristic information storage section 87 stores the information on the maximum and minimum revolution numbers of the fans 3a and 3b. The PQ characteristic information and revolution number information storage section 88 stores the total PQ characteristic of the fans 3a and 3b and the common revolution numbers of the fans 3a and 3b calculated using the fan PQ performance calculating section 93. The PWM value information storage section 89 stores the front-stage PWM values and rear-stage PWM values calculated using the fan PWM value calculating section 94.

[0115] The system impedance calculating section 91 calculates each system impedance of each configuration of the electronic equipment 50 on the basis of the information on the measured system impedances stored in the measured system impedance information storage section 81 and the information on the configurations of the electronic equipment 50 stored in the equipment configuration information storage section 82. The needed air flow rate calculating section 92 calculates the needed air flow rates on the basis of the temperatures stored in the temperature information storage section 84 and the temperature standard values stored in the temperature standard value information storage section 85.

[0116] The fan PQ performance calculating section 93 calculates the total PQ characteristic of the fans 3a and 3b and the common revolution numbers of the fans 3a and 3b. The calculation is performed on the basis of information on the system impedances stored in the system impedance information storage section 83, the needed air flow rates stored in the needed air flow rate information storage section 86 and the maximum and minimum revolution numbers of the fans 3a and 3b stored in the measured PQ characteristic information storage section 87 and the total PQ characteristic of the fans 3a and 3b and the common revolution numbers of the fans 3a and 3b stored in the PQ characteristic information and revolution number information storage section 88.

[0117] Next, procedures of preparing the heating-element-temperature-based PWM value determination tables 71a to 71c and the environmental-temperature-based PWM value determination tables 72a to 72c will be described. FIG. 10 is a flowchart illustrating an example of procedures of preparing the heating-element-temperature-based PWM value determination tables 71a to 71c and the environmental-temperature-based PWM value determination tables 72a to 72c.

[0118] As illustrated in FIG. 10, as work to be previously performed in preparation of the heating-element-temperature-based PWM value determination tables 71a to 71c and the environmental-temperature-based PWM value determination tables 72a to 72c, first, measurement and simulation are performed (step S101). Specifically, system impedances corresponding to the full and popular configurations of the

electronic equipment, and maximum and minimum revolution numbers, air flow rates, static pressures and noise levels of the fans **3a** and **3b** are obtained by the measurement and simulation.

[0119] Next, various calculations are performed on the basis of the information obtained at step **S101** using the database preparing section **184** (step **S102**). Specifically, each system impedance of each equipment configuration and each needed air flow rate, each common revolution number, each front-stage PWM value and each rear-stage PWM value at each temperature are calculated (step **102**).

[0120] Then, each system impedance calculated for each equipment configuration and each needed air flow rate, each common revolution number, each front-stage PWM value and each rear-stage PWM value which are calculated at each of the environmental temperature and the heating element temperatures are arranged in the form of databases and stored in the ROM **17** (step **S103**). Owing to the above mentioned operations, the heating-element-temperature-based PWM value determination tables **71a** to **71c** and the environmental-temperature-based PWM value determination tables **72a** to **72c** are stored in the ROM **17**. The fan control device **1** is then incorporated into the electronic equipment **50** in a state in which the heating-element-temperature-based PWM value determination tables **71a** to **71c** and the environmental-temperature-based PWM value determination tables **72a** to **72c** are stored in the ROM **17**.

[0121] Next, specific operations of the processor **18** according to this embodiment will be described. FIG. **11** is a flowchart illustrating an example of procedures of processing executed using the processor according to the embodiment **2**. Incidentally, only a procedure involving revolution number control of the front-stage fan **3a** and the rear-stage fan **3b** of the procedures of processing executed using the processor **18** is illustrated in FIG. **11**.

[0122] As illustrated in FIG. **11**, first, the input value determining section **183** acquires an equipment state (step **S201**). Specifically, the input value determining section **183** specifies a system impedance to which an equipment state specification flag is set as the system impedance corresponding to the current configuration of the electronic equipment **50** with reference to data stored in the equipment state storage section **171**.

[0123] Next, the input value determining section **183** selects a database corresponding to the specified system impedance (step **S202**). Specifically, the input value determining section **183** selects one heating-element-temperature-based PWM value determination table from within the heating-element-temperature-based PWM value determination tables **71a** to **71c** and one environmental-temperature-based PWM value determination table from within the environmental-temperature-based PWM value determination tables **72a** to **72c**.

[0124] Next, the processor **18** executes temperature measurement (step **S203**). Specifically, the temperature information acquiring section **182** acquires predetermined variables corresponding to temperatures of the heating elements **52a** and **52b** from the temperature check sections **12a** and **12b** as heating element temperatures and acquires an environmental temperature from the temperature sensor **12c**. The temperature information acquiring section **182** then notifies the input value determining section **183** of the acquired heating element and environmental temperatures.

[0125] Next, the input value determining section **183** selects a common revolution number corresponding to the heating element temperatures acquired at step **S203** with reference to the heating-element-temperature-based PWM determination table (step **S204**). The input value determining section **183** also selects a common revolution number corresponding to the environmental temperature acquired at step **S203** with reference to the environmental-temperature-based PWM value determination table (step **S205**).

[0126] Next, the input value determining section **183** judges whether the heating-element-temperature-based common revolution number is larger than the environmental-temperature-based common revolution number (step **S206**). In the above mentioned process, in the case that it has been judged that the common revolution number obtained from the heating element temperature is larger than the common revolution number obtained from the environmental temperature (Yes at step **S206**), the input value determining section **183** determines the PWM values of pulses to be input into the fans **3a** and **3b** using the heating-element-temperature-based PWM value determination table **71**.

[0127] Specifically, the input value determining section **183** determines the front-stage PWM value corresponding to the common revolution number selected at step **S204** with reference to the heating-element-temperature-based PWM value determination table **71** (step **S207**). The input value determining section **183** then determines the rear-stage PWM value corresponding to the front-stage PWM value with reference to the heating-element-temperature-based PWM value determination table **71** (step **S208**). For example, in the case that the current system impedance of the electronic equipment **50** is "A" and the heating element temperature acquired using the temperature information acquiring section **182** is "C", the input value determining section **183** selects the common revolution number "ccc" with reference to the heating-element-temperature-based PWM value determination table **71a** illustrated in FIG. **7A**. Then, the input value determining section **183** determines the front-stage PWM value "Nfc" and the rear-stage PWM value "Nrc" corresponding to the common revolution number "ccc" as the PWM values of the pulses to be input into the fans **3a** and **3b**.

[0128] On the other hand, at step **S204**, it has been judged that the heating-element-temperature-based common revolution number is not larger than the environmental-temperature-based common revolution number (No at step **S206**); the input value determining section **183** determines the PWM values of pulses to be input into the fans **3a** and **3b** by using the heating-element-temperature-based PWM value determination table **71**.

[0129] Specifically, the input value determining section **183** determines a front-stage PWM value corresponding to the common revolution number selected at step **S205** with reference to the environmental-temperature-based PWM value determination table **72** (step **S209**). The input value determining section **183** determines a rear-stage PWM value corresponding to the front-stage PWM value with reference to the heating-element-temperature-based PWM value determination table **71** (step **S210**). For example, in the case that the current system impedance of the electronic equipment **50** is "A" and the environmental temperature acquired using the temperature information acquiring section **182** is "G", the input value determining section **183** selects the common revolution number "ggg" with reference to the environmental-temperature-based PWM value determination table **72a** as

illustrated in FIG. 7B. The input value determining section 183 then determines the front-stage PWM value “Nfg” and the rear-stage PWM value “Nrg” corresponding to the common revolution number “ggg” as the PWM values of pulses to be input into the fans 3a and 3b.

[0130] At the completion of execution of the process at step S208 or step S210, the input value determining section 183 instructs to rotate the fans (step S211). That is, the input value determining section 183 instructs the pulse generators 15a and 15b to input pulses of the front-stage and rear-stage PWM values determined at steps S207 and S208 or at steps S209 and S210 respectively into the front-stage fan 3a and the rear-stage fan 3b. In response to the instruction, the pulse generator 15a inputs the pulse of the above front-stage PWM value into the front-stage fan 3a as instructed from the input value determining section 183. Likewise, the pulse generator 15b inputs the pulse of the above rear-stage PWM value into the rear-stage fan 3b as instructed from the input value determining section 183. As a result, the front-stage fan 3a and the rear-stage fan 3b rotate with the revolution numbers corresponding to the front-stage PWM value and the rear-stage PWM value which have been input from the pulse generators 15a and 15b.

[0131] Incidentally, as described above, the front-stage PWM value and the rear-stage PWM value are PWM values of pulses to be input into the fans 3a and 3b in order to obtain the needed air flow rate in a state in which the difference in revolution number between the fans 3a and 3b is maintained in the predetermined tolerance. Therefore, the fans 3a and 3b rotate in a state in which the revolution numbers of the fans coincide with each other in the predetermined tolerance by inputting the pulses of the above front-stage and rear-stage PWM values respectively into the fans 3a and 3b and air is fed into the heating elements 52a and 52b at the needed air flow rates conforming to the temperatures of the heating elements 52a and 52b.

[0132] FIG. 12 is a diagram illustrating an effect of the embodiment. In FIG. 12, a left part is a graph indicative of changes in static pressure, revolution number and noise relative to a change in air flow rate obtained when the PWM values of the pulses applied to the front-stage fan 3a and the rear-stage fan 3b are made the same as each other at a predetermined temperature.

[0133] As illustrated in the graph, in the case that pulses of the same PWM value have been applied to the fans 3a and 3b, if it is intended to obtain a needed air flow rate 3003 at which the total aerodynamic performance 3001 of the fans 3a and 3b intersects the system impedance 3002, the revolution number of the rear-stage fan 3b (the rear-stage revolution number 3004B) will become larger than the revolution number of the front-stage fan 3a (the front-stage revolution number 3004A). The reason therefore lies in the fact that the work amount with which the rear-stage fan 3b blows off air is reduced under the influence of the air currents generated from the front-stage fan 3a to increase the revolution number of the rear-stage fan 3b. The noise 3005 is also increased with increasing the revolution number of the rear-stage fan 3b.

[0134] On the other hand, in FIG. 12, a right part is a graph indicative of changes in static pressure, revolution number and noise relative to a change in air flow rate obtained in the case that the fan control device 1 according to this embodiment has controlled such that the difference in revolution number (4004A, 4004B) between the front-stage fan 3a and the rear-stage fan 3b is maintained in the predetermined tol-

erance at a predetermined temperature. As illustrated in this graph, according to this embodiment, it may become possible to obtain the needed air flow rate 4003 at which the system impedance 4002 within the electronic equipment 50 intersects the total aerodynamic characteristic 4001 (the PQ characteristic) of the fans 3a and 3b when the difference in revolution number between the fans 3a and 3b is maintained in the predetermined tolerance in a state in which the difference in revolution number between the fans is set in the predetermined tolerance at the predetermined temperature.

[0135] Therefore, according to this embodiment, such a situation may be avoided that the revolution number of any one of the fans becomes larger than that of another fan to generate surplus noise. In addition, according to this embodiment, the air flow rate suited to cool the heating elements 52a and 52b may be obtained in a state in which the difference in revolution number between the fans 3a and 3b is maintained in the predetermined tolerance regardless of the configuration of the electronic equipment 50 and the locations of the fans 3a and 3b within the electronic equipment 3a and 3b.

[0136] Next, results of experiments performed to validate that the noise generated from the plurality of fans 3a and 3b is reduced by using the fan control device 1 according to this embodiment will be described. Respective measurement conditions 3010 are illustrated in FIG. 13. FIG. 13 illustrates measurement conditions of the experiments for validation. As illustrated in FIG. 13, a case in which two fans of the same type are disposed in series is assumed to be a measurement condition A and a case in which two fans of the same type are disposed in series and four fans of the same type are disposed in parallel is assumed to be a measurement condition B.

[0137] Under the measurement condition A, experiments were performed under three conditions of conditions A-1 to A-3. Specifically, under the condition A-1, voltages of the same amount were supplied to the front-stage and rear-stage fans. Under the condition A-2, the same air flow rate as that under the condition A-1 was set and voltages were controlled such that the ratio of the front-stage fan revolution number to the rear-stage fan revolution number is 1:1. The condition A-2 corresponds to a condition under which the same control as that performed using the fan control device 1 according to this embodiment is performed. Under the condition A-3, the same air flow rate as that under the condition A-1 was set and voltages were controlled such that the ratio of the front-stage fan revolution number to the rear-stage fan revolution number is 1:0.9.

[0138] In addition, as illustrated in FIG. 13, under the measurement condition B, experiments were performed under four conditions of conditions B-1, B-2, B-3 and B-4. Specifically, under the condition B-1, voltages of the same amount were supplied to the front-stage and rear-stage fans. Under the condition B-2, the same air flow rate as that under the condition B-1 was set and voltages were controlled such that the ratio of the front-stage fan revolution number to the rear-stage fan revolution number is 1:1. The condition B-2 corresponds to a condition under which the same control as that performed using the fan control device 1 according to this embodiment is performed.

[0139] Under the condition B-3, voltages of the same amount which is different from that of the voltages supplied under the condition B-1 were supplied to the front-stage and rear-stage fans. Under the condition B-4, the same air flow rate as that under the condition B-3 was set and voltages were controlled such that the ratio of the front-stage fan revolution

number to the rear-stage fan revolution number is 1:1. The condition B-4 corresponds to a condition under which the same control as that performed using the fan control device 1 according to this embodiment is performed.

[0140] First, results of measurements performed under the measurement condition A will be described. FIG. 14A illustrates data indicative of the result of measurement of the front-stage fan revolution number 5001A, the rear-stage fan revolution number 5001B and the device noise 5002 performed under the measurement condition A. FIG. 14B illustrates data indicative of the result of measurement of the front-stage fan revolution number 6001A, the rear-stage fan revolution number 6001B and the consumption power 6002 performed under the measurement condition A. FIG. 14C illustrates data indicative of the result of frequency analysis of the device noise performed under the measurement condition A. FIG. 15A is a diagram 3020A illustrating a result of measurement performed under the condition A-1, FIG. 15B is a diagram 3020B illustrating a result of measurement performed under the condition A-2 and FIG. 15C is a diagram 3020C illustrating a result of measurement performed under the condition A-3.

[0141] As illustrated in FIGS. 14A and 15A, under the condition A-1, the front-stage revolution number 5001A was 12257 min^{-1} and the rear-stage revolution number 5001B was 13523 min^{-1} , indicating that in the case that voltages of the same amount have been supplied to the front-stage and rear-stage fans, the rear-stage fan revolution number 5001B is increased influenced by air currents generated from the front-stage fan. As illustrated in FIGS. 14A and 15C, under the condition A-3, the front-stage revolution number was 13643 min^{-1} and the rear-stage revolution number was 12277 min^{-1} , indicating that the front-stage fan revolution number measured under the condition A-3 is larger than the rear-stage fan revolution number measured under the condition A-1. On the other hand, as illustrated in FIGS. 14B and 15B, under the condition A-2, the front-stage revolution number was 12615 min^{-1} and the rear-stage revolution number was 12555 min^{-1} , indicating that these revolution numbers are smaller than the rear-stage revolution number measured under the condition A-1 and the front-stage revolution number measured under the condition A-3.

[0142] In addition, as illustrated in FIG. 14A and FIGS. 15A to 15C, the device noise 5002 measured under the condition A-1 was 55.5 dB(A), the device noise 5002 measured under the condition A-2 was 53.4 dB(A) and the device noise 5002 measured under the condition A-3 was 56 dB(A). That is, the device noise was the lowest when measured under the condition A-2 corresponding to a control system of the fan control device 1 according to this embodiment and was reduced from the value measured under the condition A-1 by about 2 dB(A). On the other hand, the highest device noise 5002 was measured under the condition A-3. It is thought that the reason therefore lies in the fact that the front-stage revolution number 5001A measured under the condition A-3 exhibited the highest value of the values measured under the respective conditions A-1 to A-3.

[0143] As described above, the noise generated from each fan may be reduced by controlling so as to attain a needed air flow rate in a state in which the revolution numbers of the front-stage and rear-stage fans (5001A, 5001B) are controlled to coincide with each other in the predetermined tolerance as in the case with the fan control device 1 according to this embodiment. Incidentally, the device noise 5002 under each

of the conditions A-1 to A-3 is of a value calculated on the basis of the result of analysis of the frequency of the device noise illustrated in FIG. 14C.

[0144] In addition, as illustrated in FIG. 14B and FIGS. 15A to 15C, the total consumption power 5003 of the front-stage and rear-stage fans was 7.20 W under the condition A-1, was 6.78 W under the condition A-2 and was 7.65 W under the condition A-3. That is, as in the case of the device noise 5002 the total consumption power 5003 was also the lowest when measured under the condition A-2 corresponding to that of the control system of the fan control device 1 according to this embodiment and was reduced from the value measured under the condition A-1 by about 6%. As described above, the consumption power 5003 of each fan may be reduced by controlling so as to attain the needed air flow rate in a state in which the revolution numbers of the front-stage and rear-stage fans (5001A, 5001B) are controlled to coincide with each other in the predetermined tolerance as in the case with the fan control device 1 according to this embodiment.

[0145] Next, results of measurements performed under the measurement condition B will be described. First, the results of measurements performed under the conditions B-1 and B-2 will be described. FIG. 16A illustrates data indicative of the result of measurement of the front-stage average revolution number 7001A, the rear-stage average revolution number 7002A and the device noise 7003 performed under the conditions B-1 and B-2. FIG. 16B illustrates data indicative of the result of measurement of the front-stage average revolution number 7001A, the rear-stage average revolution number 7001B and the consumption power 7003 performed under the conditions B-1 and B-2. FIG. 16C illustrates data indicative of the result of frequency analysis of the device noise 7002 performed under the conditions B-1 and B-2. FIG. 17A is a diagram 3030 illustrating the result of measurement performed under the condition B-1 and FIG. 17B is a diagram 3040 illustrating the result of measurement performed under the condition B-2. In the examples illustrated in the drawings, the front-stage average revolution number 7001A is the average value of revolution numbers of four front-stage fans and the rear-stage average revolution number 7001B is the average value of revolution numbers of four rear-stage fans.

[0146] As illustrated in FIGS. 16A and 17A, the front-stage average revolution number 7001A was 14488 min^{-1} and the rear-stage average revolution number 7001B was 15548 min^{-1} under the condition B-1. These values indicate that in the case that the voltages of the same amount have been supplied to the front-stage fan and the rear-stage fan as in the case under the condition A-1, the revolution number of the rear-stage fan 7001B is increased influenced by the air currents generated from the front-stage fan. On the other hand, as illustrated in FIGS. 16A and 17B, the front-stage average revolution number 7001A was 14825 min^{-1} and the rear-stage average revolution number 7001B was 14859 min^{-1} under the condition B-2. These revolution numbers 7001A, 7001B are smaller than the rear-stage average revolution number measured under the condition B-1.

[0147] As illustrated in FIG. 16A and FIGS. 17A and 17B, the device noise 7002 under the condition B-1 was 62.6 dB(A) and the device noise 7002 under the condition B-2 was 61.6 dB(A). That is, as in the case under the measurement condition A, the device noise 7002 measured under the condition B-2 which is the same as that of the fan control device 1 according to this embodiment was lower than that measured

under the condition B-1 and was reduced from the value measured under the condition B-1 by about 1 db(A).

[0148] As described above, even when the front-stage fans and the rear-stage fans are disposed in series and in parallel, an effect equivalent to that attained when the front-stage fan and the rear-stage fan are disposed only in series is obtained. Incidentally, the values of the device noise illustrated in FIG. 16A were calculated on the basis of the result of analysis of the frequency of the device noise 7002 illustrated in FIG. 16C.

[0149] In addition, as illustrated in FIG. 16B and FIGS. 17A and 17B, the total consumption power 7003 of the front-stage and rear-stage fans was 43.08 W under the condition B-1 and was 41.83 W under the condition B-2. That is, the total consumption power 7003 was the lowest when measured under the condition B-2 corresponding to that of the fan control device 1 according to this embodiment and was reduced from the value measured under the condition B-1 by about 3%.

[0150] Next, results of measurements performed under the conditions B-3 and B-4 will be described. FIG. 18A illustrates data indicative of the result of measurement of the front-stage average revolution number 8001A, the rear-stage average revolution number 8001B and the device noise 8002 performed under the conditions B-3 and B-4, FIG. 18B illustrates data indicative of the result of measurement of the front-stage average revolution number 8001A, the rear-stage average revolution number 8001B and the consumption power 8003 performed under the conditions 18-3 and 18-4 and FIG. 18C illustrates data indicative of the result of analysis of the frequency of the device noise 8002 performed under the conditions B-3 and B-4. FIG. 19A is a diagram 3050 illustrating the result of measurement performed under the condition B-3 and FIG. 19B is a diagram 3060 illustrating the result of measurement performed under the condition B-3.

[0151] As illustrated in FIGS. 18A and 19A, under the condition B-3, the front-stage average revolution number 8001A was 12576 min^{-1} and the rear-stage average revolution number was 13354 min^{-1} . This result is the same as those attained under the conditions A-1 and B-1. On the other hand, as illustrated in FIGS. 18A and 19B, under the condition B-4, the front-stage average revolution number was 12826 min^{-1} and the rear-stage average revolution number 8001B was 12809 min^{-1} . That is, these values are smaller than the value of the rear-stage average revolution number 8001B measured under the condition B-3.

[0152] As illustrated in FIG. 18A and FIGS. 19A and 19B, the device noise 8002 under the condition B-3 was 58.7 db(A) and the device noise 8002 under the condition B-4 was 57.7 db(A). That is, the device noise 8002 measured under the condition B-4 which is the same as that of the fan control device 1 according to this embodiment was lower than that measured under the condition B-3 and was reduced from the value measured under the condition B-3 by about 1 db(A) as in the case in the relation between the conditions B-1 and B-2.

[0153] As described above, it has been found that even when the air flow rates of air generated from each front-stage fan and each rear-stage fan are varied, the same result may be obtained by changing the amount of voltages applied in the case that the front-stage fans and the rear-stage fans are disposed in series and in parallel. Incidentally, the values of the device noise illustrated in FIG. 18A are calculated on the basis of the result of analysis of the frequency of the device noise illustrated in FIG. 18C.

[0154] As illustrated in FIG. 18B and FIGS. 19A and 19B, the total consumption power 8003 of the front-stage and rear-stage fans was 27.80 W under the condition B-3 and was 26.87 W under the condition B-4. That is, the total consumption power 8003 was also the lowest when measured under the condition B-4 which is the same as that of the fan control device 1 according to this embodiment as in the case in the relation between the conditions B-1 and B-2 and was reduced from the value measured under the condition B-3 by about 3%.

[0155] As described above, according to the embodiment 2, the air flow rate of air cooling the heating elements 52a and 52b which is determined from the temperatures of the heating elements 52a and 52b, the system impedance within the electronic equipment 50 and the total PQ characteristic of the fans 3a and 3b attained in a state in which the difference in revolution number between the fans 3a and 3b is maintained in the predetermined tolerance is obtained. In addition, the revolution number of each of the fans 3a and 3b is controlled on the basis of the temperatures of the heating elements and the environmental temperature such that the difference in revolution number between the fans 3a and 3b is set in the predetermined tolerance. That is, in the embodiment 2, the revolution number of each of the fans 3a and 3b is controlled on the basis of the heating element temperatures and the environmental temperature such that the needed air flow rate which is needed for cooling the heating elements 52a and 52b and is determined from the temperatures of the heating elements 52a and 52b, the system impedance within the electronic equipment 50 and the total PQ characteristic of the fans 3a and 3b obtained in a state in which the revolution numbers of the fans 3a and 3b are controlled to coincide with each other in the predetermined tolerance may be obtained in a state in which the revolution numbers of the fans 3a and 3b coincide with each other in the predetermined tolerance.

[0156] That is, according to this embodiment, such a situation that the total noise generated from the fans 3a and 3b owing to the surplus noise generated from the fan of the largest revolution number may be avoided by maintaining the difference in revolution number between the fans 3a and 3b in the predetermined tolerance. In addition, in this embodiment, the needed air flow rate may be obtained by taking the temperatures of the heating elements 52a and 52b, the system impedance within the electronic equipment 50 and the total PQ characteristic of the fans 3a and 3b obtained in a state in which the difference in revolution number between the fans 3a and 3b is in the predetermined tolerance into consideration. Therefore, according to this embodiment, the air flow rate suited to cool the heating elements 52a and 52b may be obtained in a state in which the difference in revolution number between the fans 3a and 3b is maintained in the predetermined tolerance regardless of the configuration of the electronic equipment 50 concerned and the locations of the respective fans 3a and 3b within the electronic equipment 50.

[0157] As described above, according to this embodiment, the noise generated from the plurality of fans 3a and 3b may be reduced while attaining the air flow rate needed for cooling the heating elements 52A and 52B within the electronic equipment 50 using the plurality of fans 3a and 3b.

[0158] In addition, according to this embodiment, the revolution number of the rear-stage fan 3b is reduced more remarkably than that attained when the energy of the same amount is supplied to the both fans 3a and 3b and hence the service life of the rear-stage fan 3b may be increased. Further,

according to this embodiment, addition of components is not needed and hence the above mentioned effects may be realized at a cost equivalent to an ever attained cost.

[0159] Incidentally, a fan control program is stored in the ROM 17 of the fan control device 1 and functions as mentioned above are implemented by executing this fan control program using the processor 18. Next, an example of a computer for executing the fan control program will be illustrated. FIG. 20 is a functional block diagram illustrating a computer for executing the fan control program.

[0160] As illustrated in FIG. 20, a computer 600 serving as the fan control device 1 includes an HDD 610, a RAM 620, a ROM 630, a CPU 60 and a bus 650 for connecting these elements with one another. The ROM 630 corresponds to the ROM 17 illustrated in FIG. 2 and stores in advance the fan control program. The fan control program includes a temperature detection program 631 and a control program 632.

[0161] Then, the CPU 640 reads the temperature detection program 631 and the control program 632 out of the ROM 630 and executes these programs. As a result of execution of these programs, the programs 631 and 632 come to function respectively as a temperature detection process 641 and a control process 642. As described above, the CPU 640 corresponds to the processor 18 in FIG. 2.

[0162] The ROM 630 includes the equipment state storage section 171 and the control data storage section 172 and stores the equipment state management table 61, the heating-element-temperature-based PWM value determination tables 71a to 71c and the environmental-temperature-based PWM value determination tables 72a to 72c in these storage sections. The CPU 640 reads these tables stored in the ROM 630 and stores these tables in the RAM 620 such that the processes 641 and 642 execute various processes utilizing the data stored in the RAM 620.

Embodiment 3

[0163] Although, in the above mentioned embodiment 2, the evolution numbers of the fans 3a and 3b detected using the revolution number detecting sections 13a and 13b are used only for revolution number error check, the revolution numbers of the fans 3a and 3b may be utilized as feedback information used to set the difference in revolution number between the fans 3a and 3b in the predetermined tolerance. Next, an embodiment involving a case as mentioned above will be described. FIG. 21 is a block diagram illustrating a configuration of a fan control device according to an embodiment 3. Incidentally, the same numerals are assigned to parts having the same configurations as those previously described and description thereof will be omitted.

[0164] As illustrated in FIG. 21, in a fan control device 1' according to this embodiment, a processor 18' acquires information on the revolution numbers of the fans 3a and 3b from the revolution number detecting sections 13a and 13b. Next, specific configurations of the processor 18' and a ROM 17' according to this embodiment will be described herein below. FIG. 22 is a block diagram illustrating specific configurations of the processor 18' and the ROM 17' according to the embodiment 3.

[0165] As illustrated in FIG. 22, the processor 18' according to this embodiment includes the error processing section 181, the temperature information acquiring section 182, an input value determining section 183', the database preparing section 184 and a revolution number information acquiring section 185. The revolution number information acquiring

section 185 acquires information on the revolution numbers of the front-stage fan 3a and the rear-stage fan 3b respectively from the revolution number detecting sections 13a and 13b. As described above, the revolution number information acquiring section 185 and the revolution number detecting section 13a function as an example of front-stage revolution number detecting means for detecting the revolution number of the front-stage fan 3a and the revolution number information acquiring section 185 and the revolution number detecting section 13a functions as an example of rear-stage revolution number detecting means for detecting the revolution number of the rear-stage fan 3b.

[0166] The input value detecting section 183' then performs feedback control on the revolution number of the rear-stage fan 3b on the basis of information acquired from the revolution number information acquiring section 185. Specifically, in the case that a difference in revolution number between the front-stage fan 3a and the rear-stage fan 3b is out of a predetermined tolerance, the input value determining section 183' changes the revolution number of the rear-stage fan such that the difference in revolution number between the front-stage fan 3a and the rear-stage fan 3b is set in the predetermined tolerance. Processing as mentioned above is executed with reference to a rear-stage PWM value change table stored in a control data storage section 172'.

[0167] The control data storage section 172' according to this embodiment stores a PWM value for the rear-stage fan 3b obtained when a difference in evolution number between the front-stage fan 3a and the rear-stage fan 3 is reduced to have a value in the predetermined tolerance per revolution number. Next, information stored in the control data storage section 172' will be described. FIG. 23 is a diagram illustrating information stored in the control data storage section according to the embodiment 3.

[0168] As illustrated in FIG. 23, rear-stage PWM value change tables 73a to 73c corresponding to the system impedances A to C are stored in the control data storage section 172' according to this embodiment in addition to the heating-element-temperature-based PWM value determination tables 71a to 71c and the environmental-temperature-based PWM value determination tables 72a to 72c. FIG. 24 illustrates an example of the rear-stage PWM change table 73a.

[0169] As illustrated in FIG. 24, in the rear-stage PWM value change table 73a, each front-stage revolution number indicative of the revolution number of each front-stage fan 3a is stored corresponding to each rear-stage PWM value. For example, in the rear-stage PWM value change table 73a, the front-stage revolution number "jjj" is stored corresponding to the rear-stage PWM value "N_{rj}".

[0170] The rear-stage PWM value stored in the rear-stage PWM value change table 3a is a PWM value needed to control the revolution number of the rear-stage fan 3b to have a difference relative to the evolution number of the front-stage fan 3a in a predetermined tolerance. That is, for example, in the case that the revolution number "kkk" of the front-stage fan 3a has been acquired from the revolution number information acquiring section 185, the input value determining section 183' determines the rear-stage PWM value "N_{rk}" corresponding to the acquired revolution number with reference to the rear-stage PWM value change table 73a. The input value determining section 183' then inputs the pulse of the determined rear-stage PWM value "N_{rk}" into the rear-stage fan 3b via the pulse generator 15b. Owing to the above mentioned operations, even when the revolution number of the

front-stage fan **3a** differs from the revolution number of the rear-stage fan **3b**, the fan control device **1'** will be capable of performing correction such that the difference in revolution number between these fans is set in the predetermined tolerance.

[0171] Next, specific operations of the processor **18'** according to this embodiment will be described. FIG. **25** is a flowchart illustrating an example of processing executed using the processor **18'** according to the embodiment 3. Incidentally, in FIG. **25**, in procedures of processing executed using the processor **18'**, only a procedure of processing involving control of the revolution numbers of the front-stage and rear-stage fans **3a** and **3b** will be described. Processes executed at steps **S301** to **S311** in FIG. **25** are the same as the processes executed at steps **S201** to **S211** in FIG. **11** and hence description thereof will be omitted.

[0172] As illustrated in FIG. **25**, after an instruction to rotate the fans **3a** and **3b** has been given at step **S311**, the input value determining section **183'** measures the revolution numbers of the fans (step **S312**). Specifically, the input value determining section **183'** acquires information on the revolution numbers of the front-stage and rear-stage fans **3a** and **3b** from the revolution number information acquiring section **185**.

[0173] Next, the input value determining section **183'** judges whether a difference in revolution number between the front-stage and rear-stage fans is in a predetermined tolerance (step **S313**). In the case that it has been judged that the difference in revolution number between the fans is in the predetermined tolerance in execution of the above mentioned process (Yes at step **S313**), the input value determining section **183'** shifts the process to step **S312**.

[0174] On the other hand, in the case that the difference in revolution number between the fans is not in the predetermined tolerance (No at step **S313**), the input value determining section **183'** changes the rear-stage PWM value (step **S314**). Specifically, the input value determining section **183'** determines, on the basis of information on the revolution number of the front-stage fan **3a** acquired from the revolution number acquiring section **185**, the rear-stage PWM value corresponding to the acquired revolution number of the front-stage fan **3a** with reference to the rear-stage PWM value change table. The input value determining section **183'** then gives an instruction to rotate the fans (step **S315**). Specifically, the input value determining section **183'** instructs the pulse generator **15b** to input the pulse of the rear-stage PWM value which has been determined at step **S312** into the rear-stage fan **3b**. Owing to the above mentioned operation, the pulse of the rear-stage PWM value conforming to the revolution number of the front-stage fan **3a** is input into the rear-stage fan **3b** and the revolution numbers of the front-stage fan **3a** and the rear-stage fan **3b** come into coincidence with each other in the predetermined tolerance.

[0175] As described above, in the embodiment 3, in the case that the difference in revolution number between the front-stage fan **3a** and the rear-stage fan **3b** is out of the predetermined tolerance, the revolution number of the rear-stage fan is changed such that the difference in revolution numbers between the fans is set in the predetermined tolerance. Owing to the above mentioned operation, it may become possible to more set the difference in revolution number between the front-stage fan **3a** and the rear-stage fan **3b** in the predetermined tolerance.

[0176] Although several embodiments have been described in detail with reference to the accompanying drawings, these embodiments are merely examples and the embodiments may be modified in other forms which are altered and improved in a variety of ways on the basis of skills of persons in the art including the embodying aspects as described above.

[0177] For example, although in the above mentioned embodiments, the database preparing section **184** is used only in the case that heating-element-temperature-based PWM value determination tables **71a** to **71b** and the environmental-temperature-based PWM value determination tables **72a** to **72c** are prepared, the revolution numbers of the fans **3a** and **3b** may be controlled using the database preparing section **184**.

[0178] Specifically, first, the database preparing section **184** acquires the temperatures of the heating elements or the environmental temperature from the temperature information acquiring section **182**. Then, the database preparing section **184** calculates a front-stage PWM value and a rear-stage PWM value of pulses to be input into the respective fans **3a** and **3b** in the case that an air flow rate needed for cooling the heating elements **52a** and **52b** is obtained in a state in which a difference in revolution number between the fans **3a** and **3b** is in a predetermined tolerance on the basis of the acquired temperature(s). Then, the database preparing section **184** notifies the input value determining section **183** (or the input value determining section **183'**) of the calculated front-stage PWM value and rear-stage PWM value.

[0179] All examples and conditional language recited herein are intended for pedagogical purposes to aid the reader in understanding the invention and the concepts contributed by the inventor to furthering the art, and are to be construed as being without limitation to such specifically recited examples and conditions, nor does the organization of such examples in the specification relate to a showing of the superiority and inferiority of the invention. Although the embodiments of the present invention have been described in detail, it should be understood that the various changes, substitutions, and alterations could be made hereto without departing from the spirit and scope of the invention.

What is claimed is:

1. A fan controlling apparatus for controlling a plurality of fans which are tandemly arranged in ventilation direction of a chamber to control a temperature of a hot generating object placed in the chamber, comprising:

a memory for storing data of the rotational speed each of fans in relation to the temperature of the heat generating object; and

a controller for controlling the rotational speed of each of the fans respectively in dependence on the temperature of the heat generating object in reference to the data stored in the memory.

2. The fan controlling apparatus according to claim 1, wherein

the controller controls the rotational speed of each of the fans so that the difference of an actual rotational speed of each of the fans lower than predetermined value.

3. The fan controlling apparatus according to claim 1, wherein

the data that the memory stored are control parameters of each of the fans with respect to a plurality of the temperatures.

4. The fan controlling apparatus according to claim 3, wherein

the control parameters are respectively values of pulse width in accordance with the pulse width control of each fan, and

the parameters are respectively parameters corresponding to pulse width inputs to each of the fans.

5. The fan controlling apparatus according to claim 1, wherein

the controller controls the rotational speed of each of the fans so that the difference of an actual rotational speed of each of the fans lower than 10 percents.

6. A fan controlling method for controlling a plurality of fans which are tandemly arranged in ventilation direction of a chamber to control a temperature of a hot generating object placed in the chamber, comprising:

detecting the temperature of a hot generating object; and controlling the rotational speed of each of the fans respectively in dependence on the temperature detected in reference to data stored in the memory, the memory storing the data of the rotational speed each of fans in relation to the temperature of the heat generating object.

7. The fan controlling method according to claim 6, wherein

the controlling controls the rotational speed of each of the fans so that the difference of an actual rotational speed of each of the fans lower than predetermined value.

8. The fan controlling method according to claim 6, wherein

the data that the memory stored are control parameters of each of the fans with respect to a plurality of the temperatures.

9. The fan controlling method according to claim 8, wherein

the control parameters are respectively values of pulse width in accordance with the pulse width control of each fan, and

the parameters are respectively parameters corresponding to pulse width inputs to each of the fans.

10. The fan controlling method according to claim 6, wherein

the controlling controls the rotational speed of each of the fans so that the difference of an actual rotational speed of each of the fans lower than 10 percents.

11. A computer-readable recording medium storing a computer program controlling a plurality of fans which are tandemly arranged in ventilation direction of a chamber to control a temperature of a hot generating object placed in the chamber, the program being designed to make a computer perform the steps of:

detecting the temperature of a hot generating object; and controlling the rotational speed of each of the fans respectively in dependence on the temperature detected in reference to data stored in the memory, the memory storing the data of the rotational speed each of fans in relation to the temperature of the heat generating object.

* * * * *