



US 20070138119A1

(19) **United States**

(12) **Patent Application Publication**  
**Schwerdlin**

(10) **Pub. No.: US 2007/0138119 A1**

(43) **Pub. Date: Jun. 21, 2007**

(54) **COLLAPSIBLE CLOTHES DRYING RACK**

(52) **U.S. Cl. .... 211/202**

(75) **Inventor: Robert C. Schwerdlin, Bolingbrook, IL (US)**

(57) **ABSTRACT**

Correspondence Address:  
**NEAL, GERBER, & EISENBERG**  
**SUITE 2200**  
**2 NORTH LASALLE STREET**  
**CHICAGO, IL 60602 (US)**

A collapsible clothes drying rack is disclosed herein. An embodiment of the collapsible drying rack has a first frame member that is collapsible between a folded position and an extended position. The first frame member may have a first locking arm engaged thereto. The embodiment may also have a plurality of rods, wherein each rod may be of equal length. Each rod may have a first end and a second end, and the first end of each rod may be selectively engaged to either the first frame member or the first locking arm. The embodiment may also have a second frame member collapsible between a folded position and an extended position. The second frame member may have a second locking arm engaged thereto. The second end of each of rod may be selectively engaged to either the second frame member or the second locking arm.

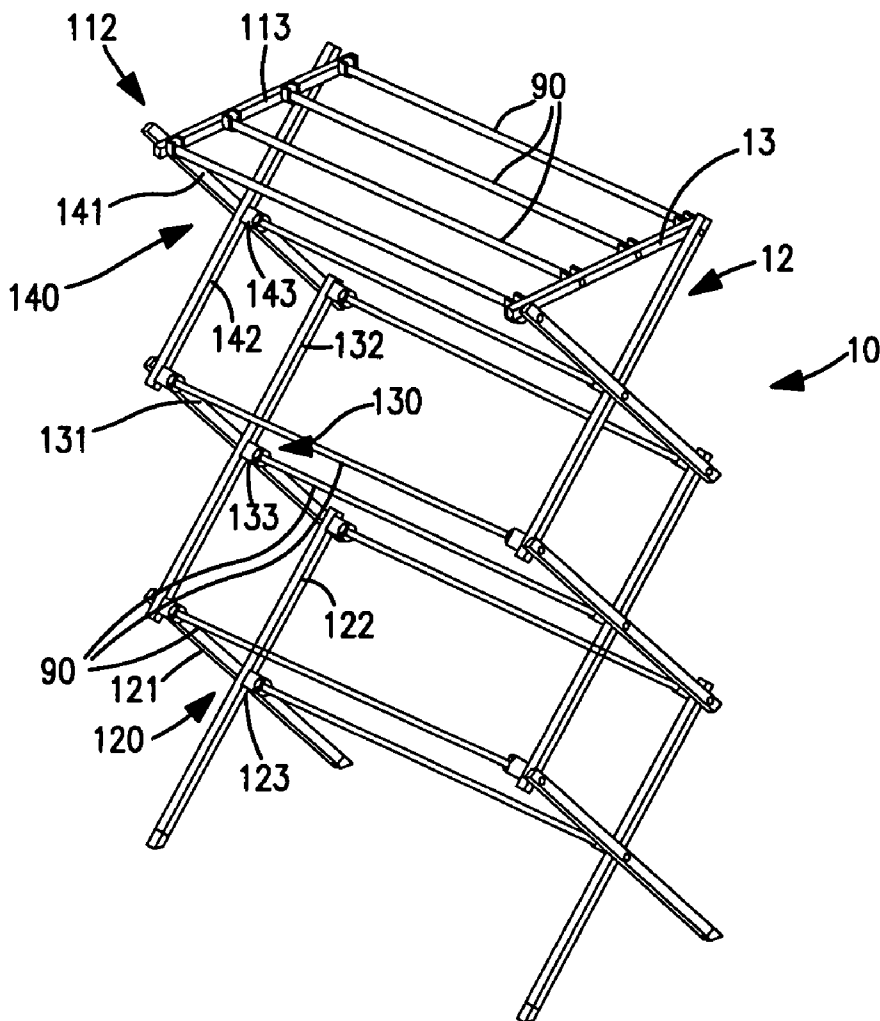
(73) **Assignee: Home Products International, Inc., Chicago, IL**

(21) **Appl. No.: 11/312,190**

(22) **Filed: Dec. 19, 2005**

**Publication Classification**

(51) **Int. Cl. A47B 43/00 (2006.01)**



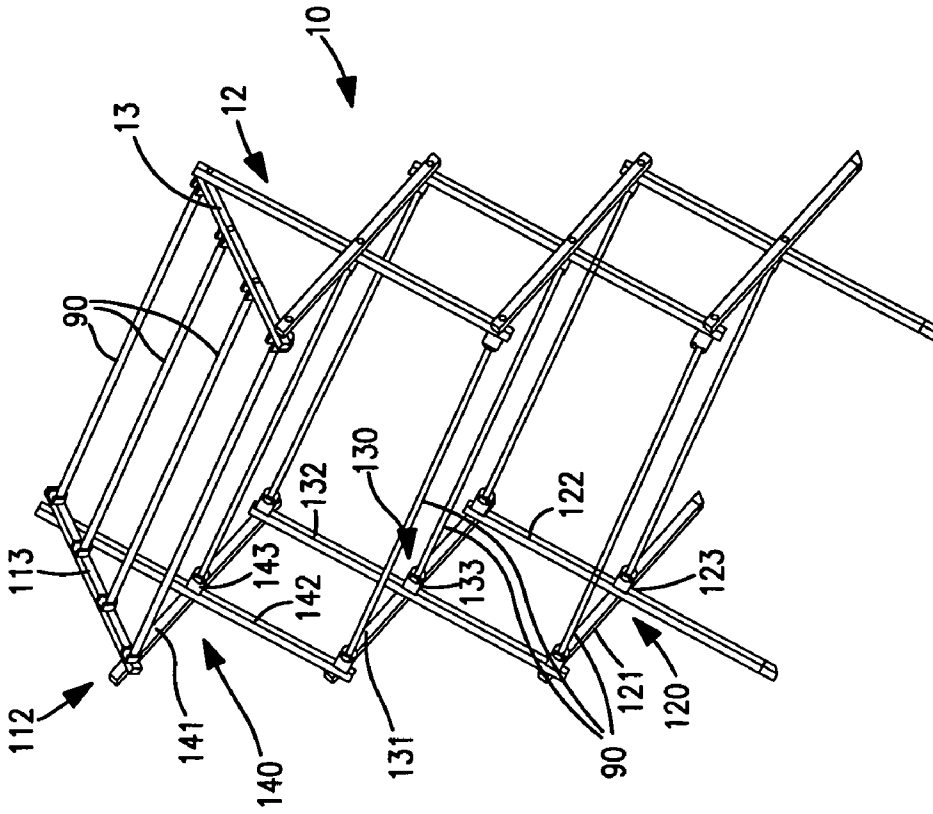


FIG. 1

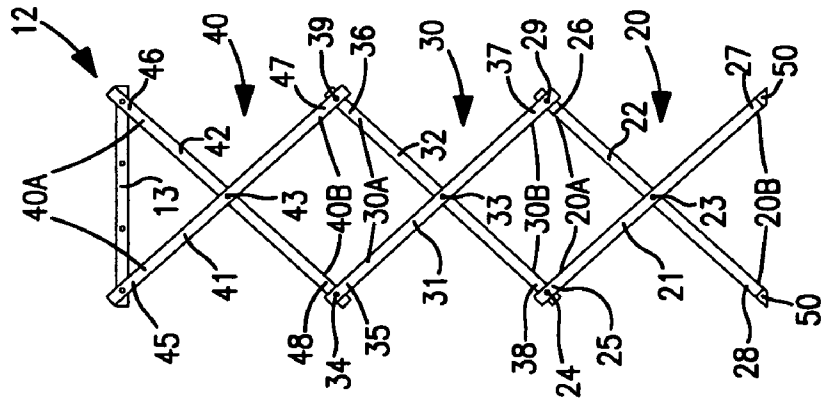


FIG. 2

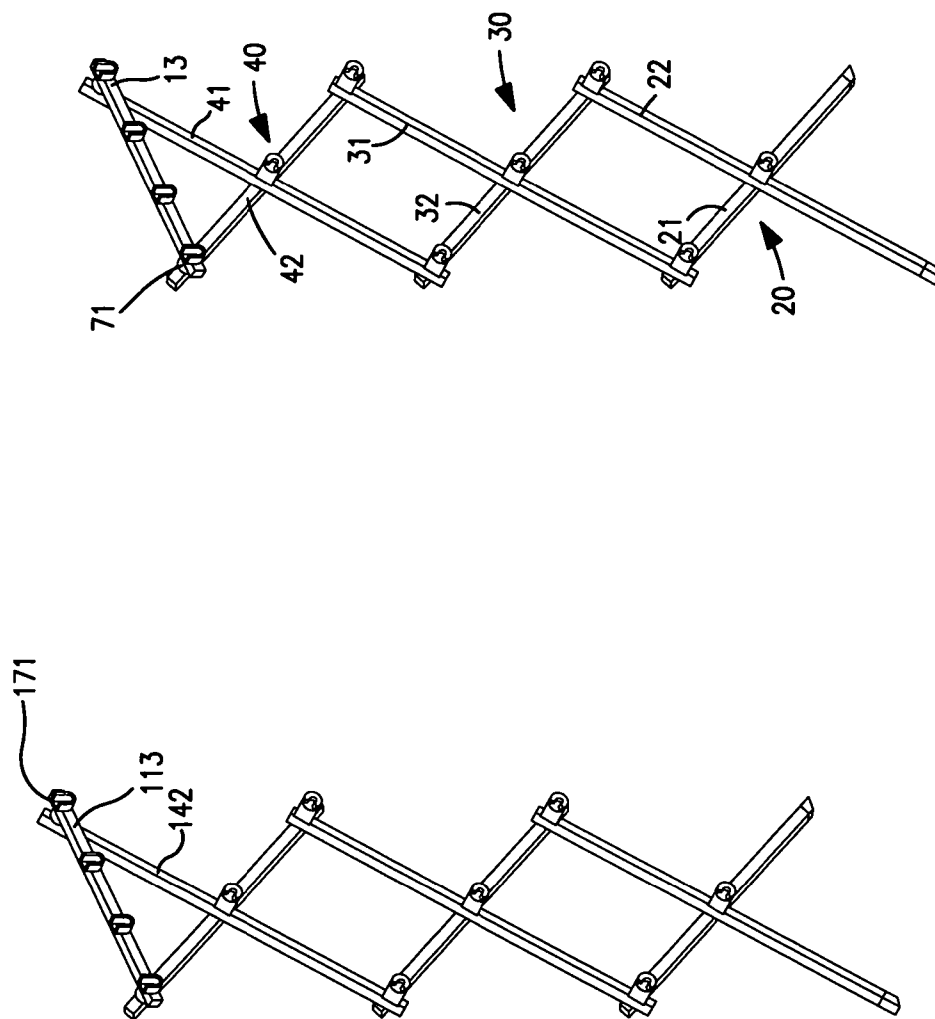
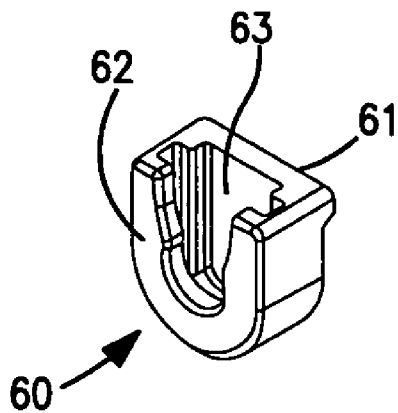
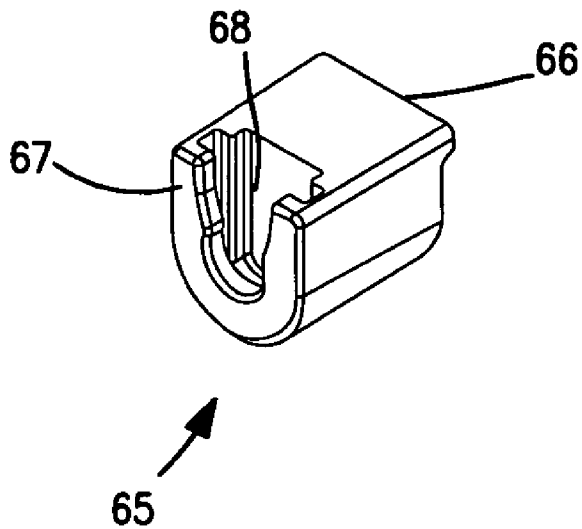


FIG. 4

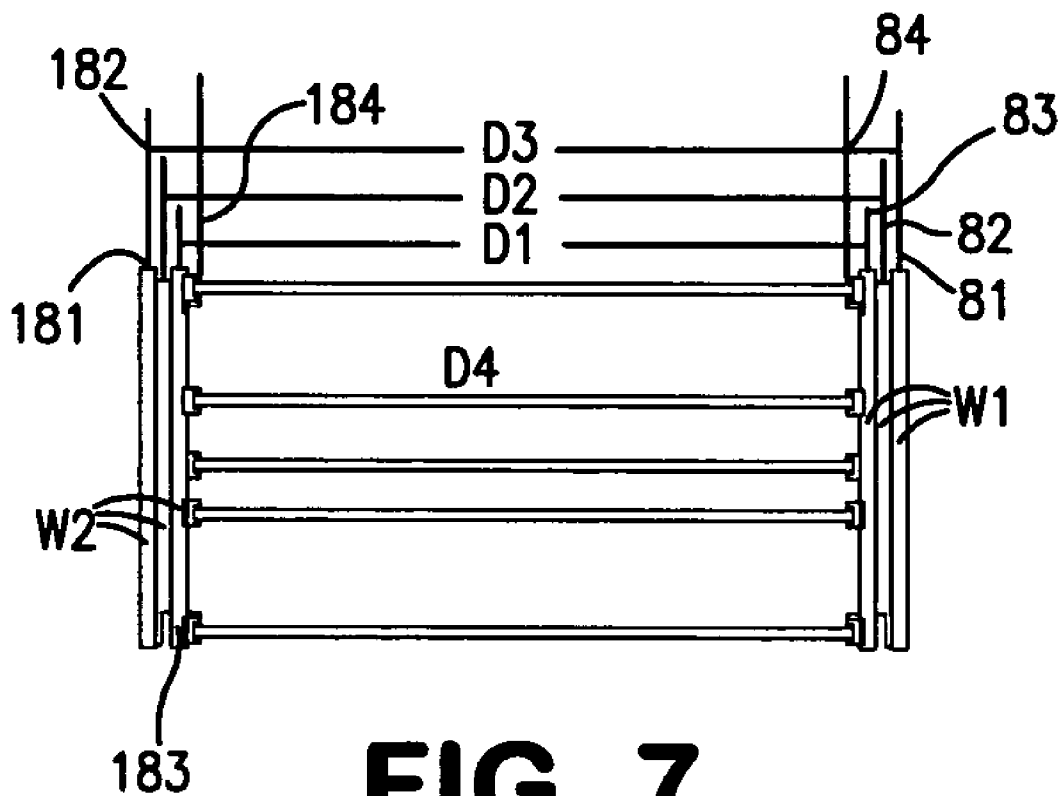
FIG. 3



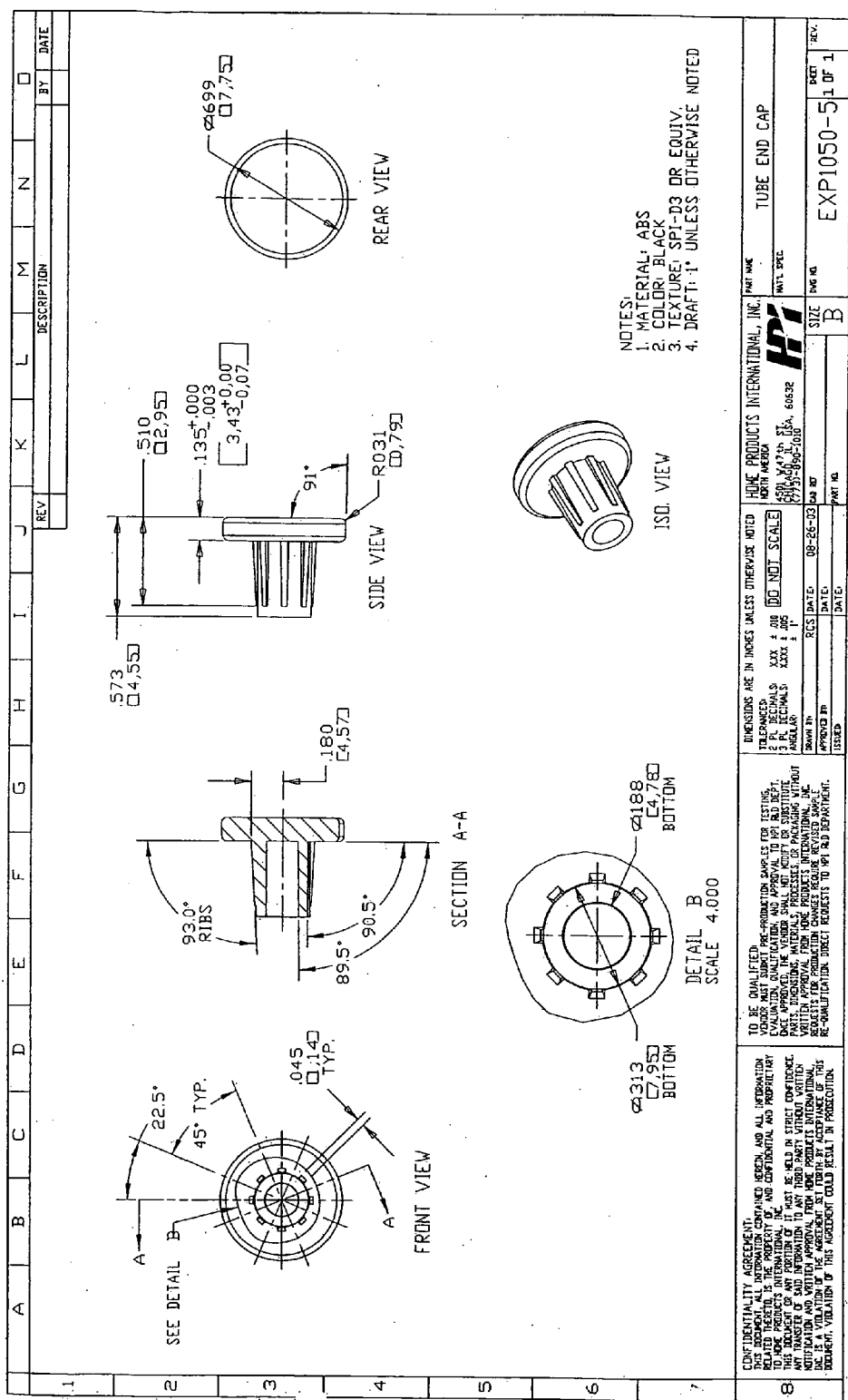
**FIG. 5**



**FIG. 6**

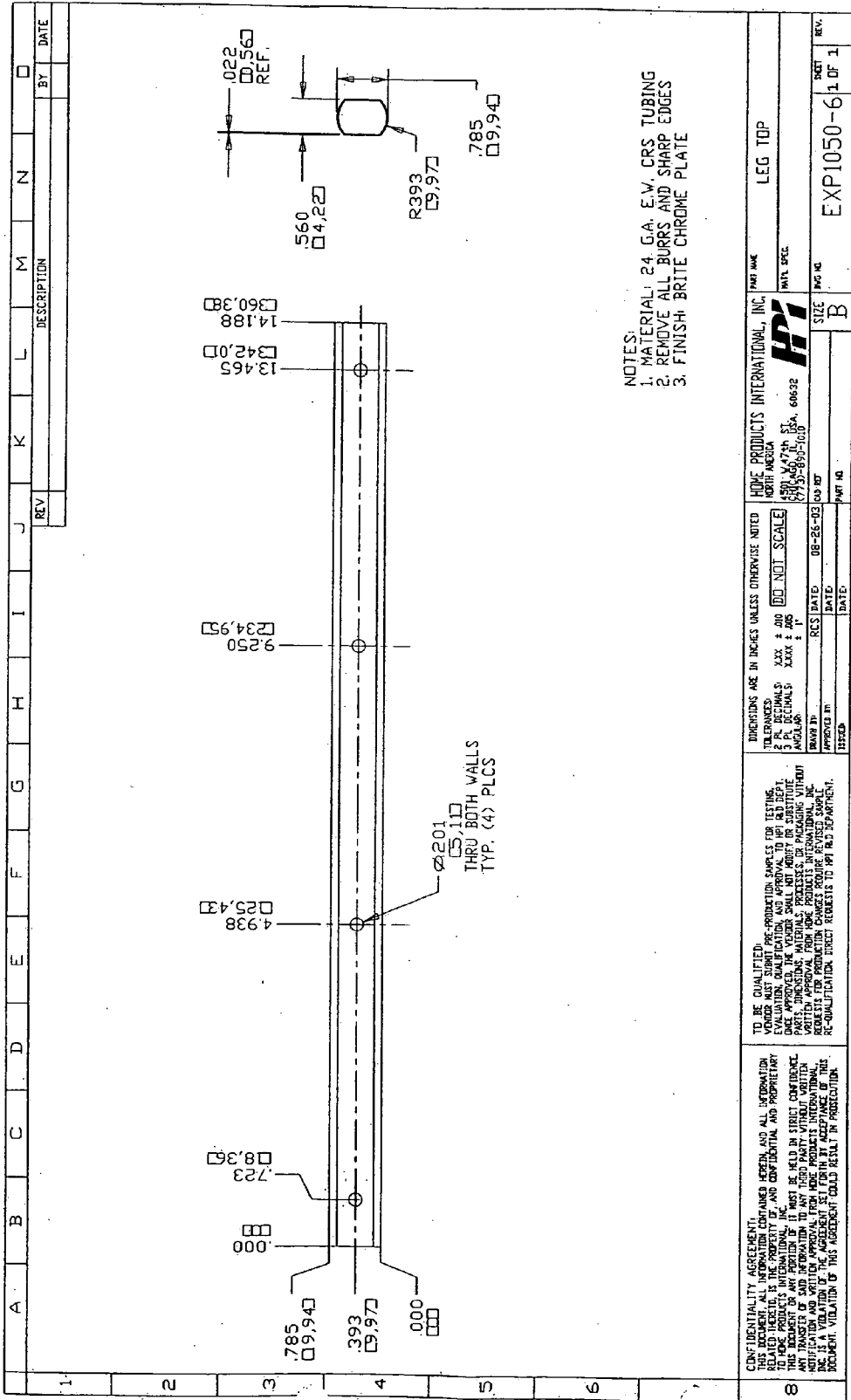


**FIG. 7**

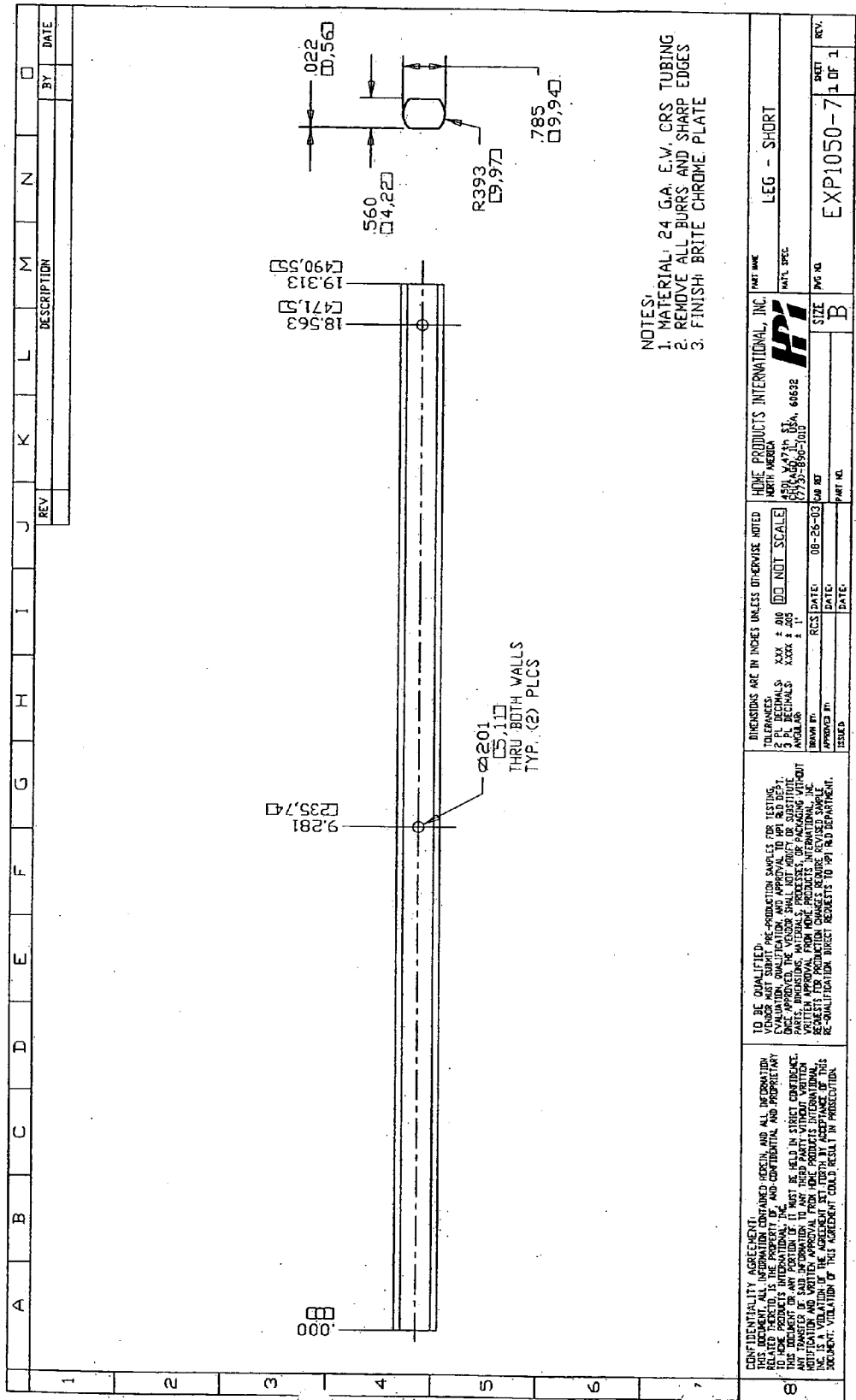


NOTES:  
 1. MATERIAL: ABS  
 2. COLOR: BLACK  
 3. TEXTURE: SPI-D3 OR EQUIV.  
 4. DRAFT: 1° UNLESS OTHERWISE NOTED

CONFIDENTIALITY AGREEMENT: THIS DOCUMENT IS THE PROPERTY OF HOME PRODUCTS INTERNATIONAL, INC. AND CONTAINS CONFIDENTIAL AND PROPRIETARY INFORMATION. IT IS TO BE KEPT IN STRICT CONFIDENCE. NO DISCLOSURE OR REPRODUCTION OF THIS INFORMATION IS PERMITTED WITHOUT THE WRITTEN APPROVAL OF HOME PRODUCTS INTERNATIONAL, INC. HOME PRODUCTS INTERNATIONAL, INC. ACCEPTS NO LIABILITY FOR DAMAGES OF ANY KIND, INCLUDING REASONABLE ATTORNEY'S FEES, ARISING FROM THE USE OF THIS INFORMATION. VIOLATION OF THIS AGREEMENT COULD RESULT IN PROSECUTION.		DIMENSIONS ARE IN INCHES UNLESS OTHERWISE NOTED TELEPHONICS 5 IN. DECIMALS 3 ANGULAR XXX # ARE DO NOT SCALE ACC. 1" DRAWN BY: 08-26-03 APPROVED BY: [DATE] ISSUED: [DATE]		PART NAME: TUBE END CAP MTL SPEC: [SPEC] SIZE: B		PART NO: EXP1050-51 OF 1 REV: [REV]	
HOME PRODUCTS INTERNATIONAL, INC. NORTH AMERICA 4501 W. 47th St. Minneapolis, MN 55412-1008 (612) 835-3300		DRAWN BY: 08-26-03 APPROVED BY: [DATE] ISSUED: [DATE]		PART NO: EXP1050-51 OF 1 REV: [REV]		PART NO: EXP1050-51 OF 1 REV: [REV]	



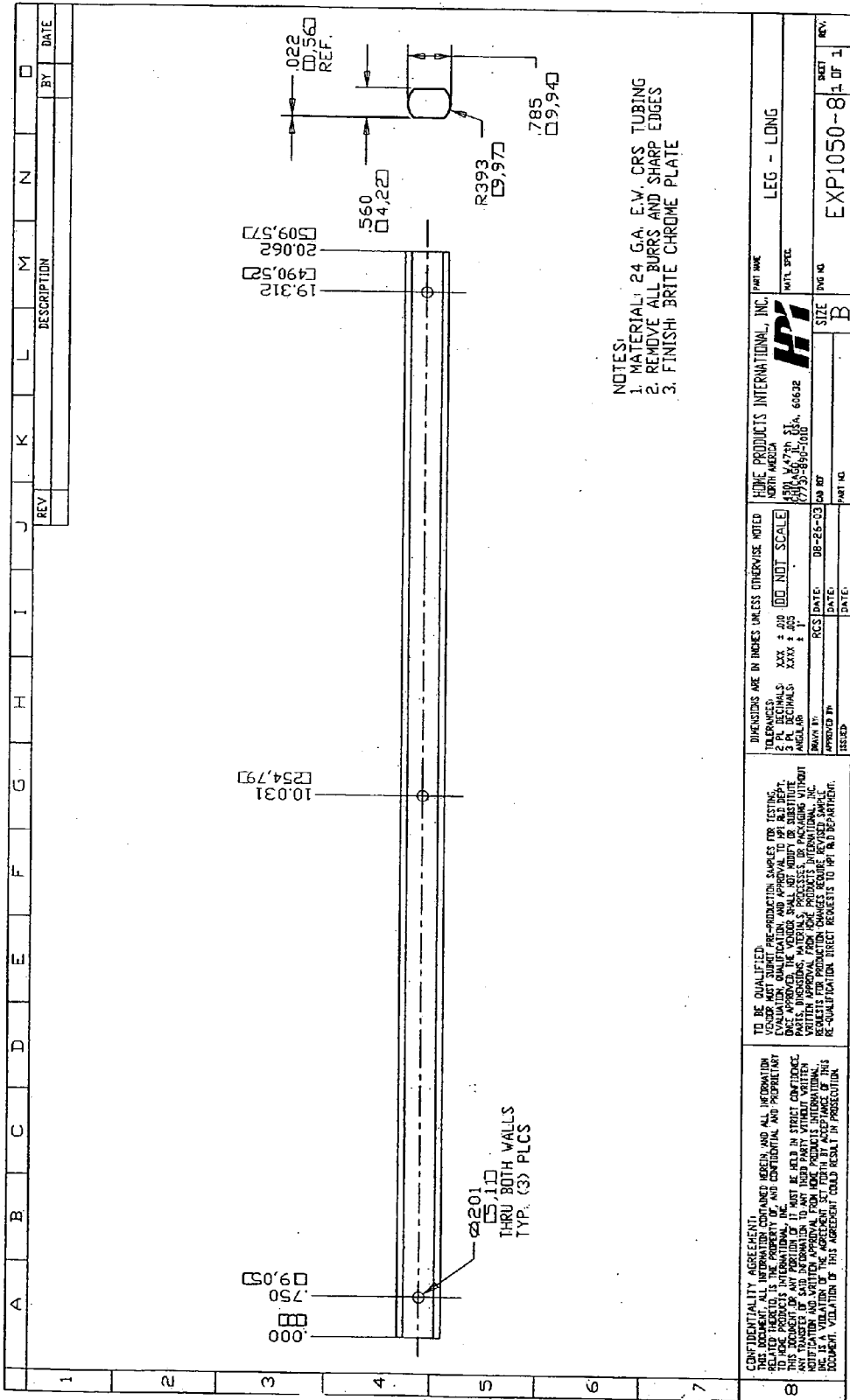
NOTES:  
 1. MATERIAL: 24 G.A. E.V. CRS TUBING  
 2. REMOVE ALL BURRS AND SHARP EDGES  
 3. FINISH: BRITE CHROME PLATE



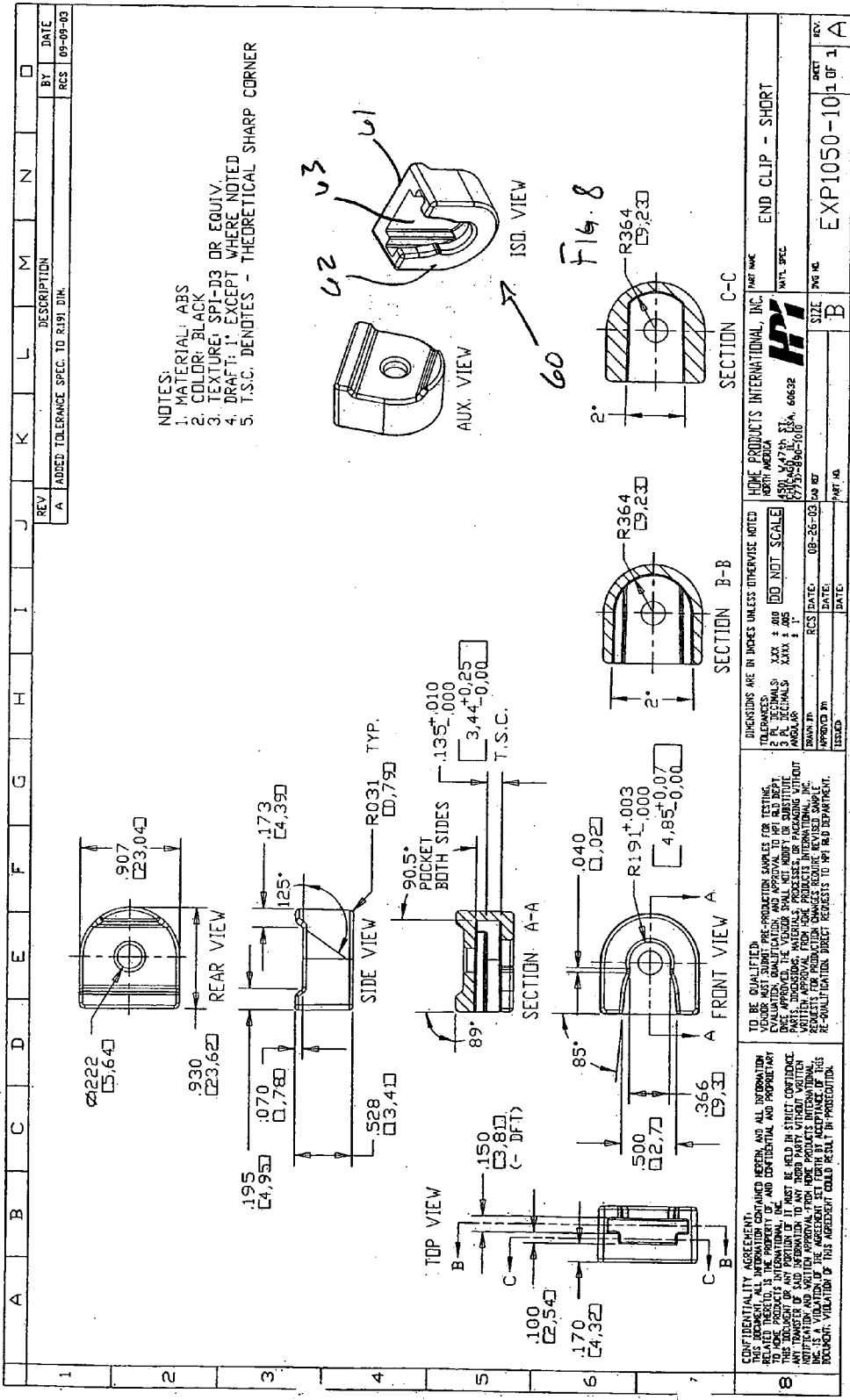
- NOTES:
1. MATERIAL: 24 G.A. E.V. CRS TUBING
  2. REMOVE ALL BURRS AND SHARP EDGES
  3. FINISH: BRITE CHROME PLATE

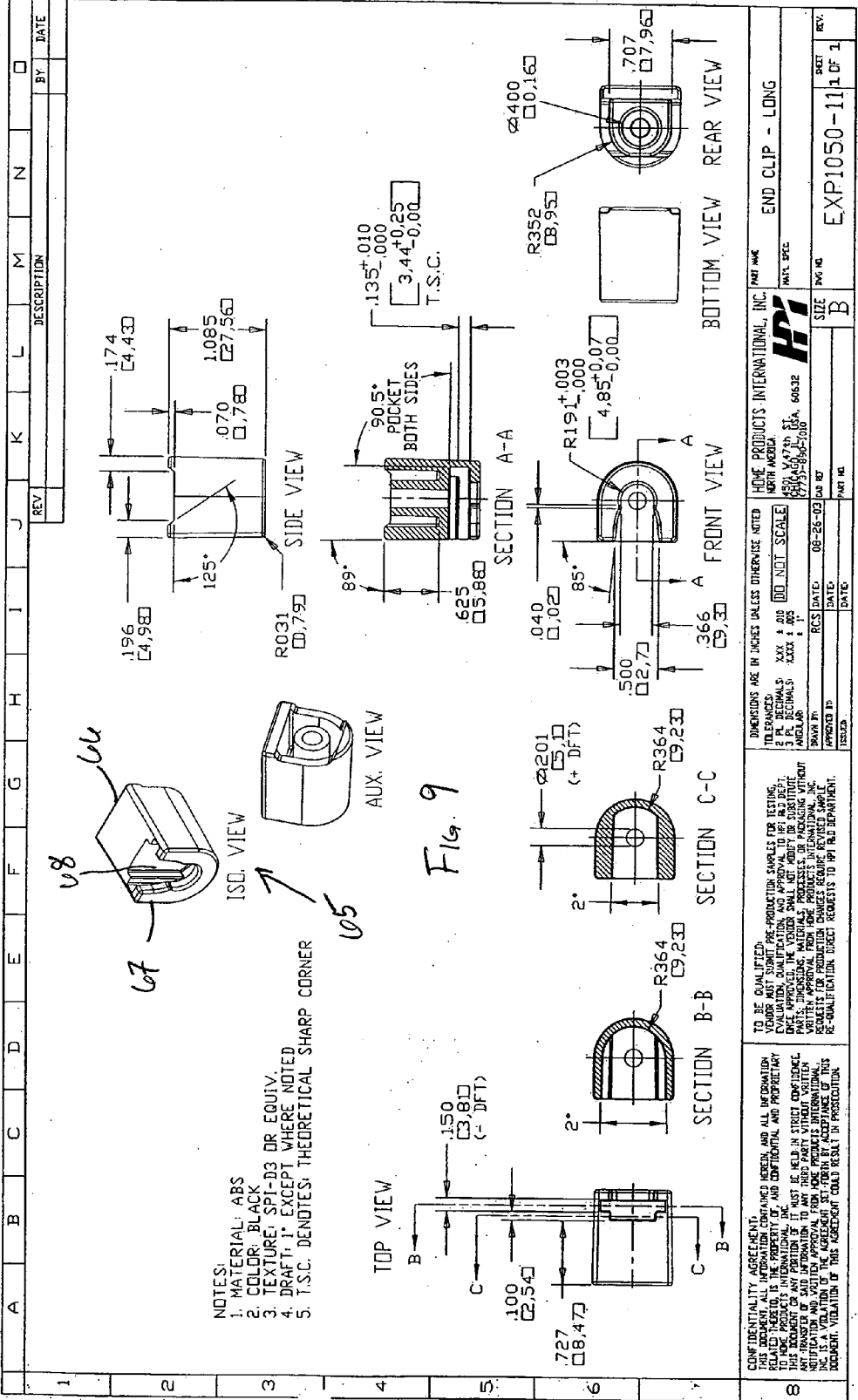
CONFIDENTIALITY AGREEMENT. THIS DOCUMENT CONTAINS INFORMATION OF A CONFIDENTIAL AND PROPRIETARY NATURE. IT IS THE PROPERTY OF HOME PRODUCTS INTERNATIONAL, INC. AND IS TO BE KEPT IN STRICT CONFIDENCE. IT IS NOT TO BE REPRODUCED OR TRANSMITTED IN ANY FORM OR BY ANY MEANS, WITHOUT THE WRITTEN APPROVAL OF HOME PRODUCTS INTERNATIONAL, INC. A VIOLATION OF THIS AGREEMENT MAY BE CAUSAL TO LEGAL ACTION.		TO BE QUALIFIED. VENDOR MUST SUBMIT PRE-PRODUCTION SAMPLES FOR TESTING, EVALUATION, QUALIFICATION, AND APPROVAL TO SPI AND DEPT. 2 PL. DECIMALS XXX ± .005. PAGES, INDICATIONS, MATERIAL SPECIFICATIONS, AND WRITTEN APPROVAL FROM HOME PRODUCTS INTERNATIONAL, INC. REQUESTS FOR PRODUCTION CHANGES REQUIRE REVISED SAMPLES. RE-QUALIFICATION SUBJECT REQUESTS TO SPI AND DEPARTMENT.		DIMENSIONS ARE IN INCHES UNLESS OTHERWISE NOTED. TOLERANCES: 2 PL. DECIMALS XXX ± .005. 3 PL. DECIMALS XXX ± .005. 4 PL. DECIMALS XXX ± .005. 5 PL. DECIMALS XXX ± .005. 6 PL. DECIMALS XXX ± .005. 7 PL. DECIMALS XXX ± .005. 8 PL. DECIMALS XXX ± .005. 9 PL. DECIMALS XXX ± .005. 10 PL. DECIMALS XXX ± .005. 11 PL. DECIMALS XXX ± .005. 12 PL. DECIMALS XXX ± .005. 13 PL. DECIMALS XXX ± .005. 14 PL. DECIMALS XXX ± .005. 15 PL. DECIMALS XXX ± .005. 16 PL. DECIMALS XXX ± .005. 17 PL. DECIMALS XXX ± .005. 18 PL. DECIMALS XXX ± .005. 19 PL. DECIMALS XXX ± .005. 20 PL. DECIMALS XXX ± .005. 21 PL. DECIMALS XXX ± .005. 22 PL. DECIMALS XXX ± .005. 23 PL. DECIMALS XXX ± .005. 24 PL. DECIMALS XXX ± .005. 25 PL. DECIMALS XXX ± .005. 26 PL. DECIMALS XXX ± .005. 27 PL. DECIMALS XXX ± .005. 28 PL. DECIMALS XXX ± .005. 29 PL. DECIMALS XXX ± .005. 30 PL. DECIMALS XXX ± .005. 31 PL. DECIMALS XXX ± .005. 32 PL. DECIMALS XXX ± .005. 33 PL. DECIMALS XXX ± .005. 34 PL. DECIMALS XXX ± .005. 35 PL. DECIMALS XXX ± .005. 36 PL. DECIMALS XXX ± .005. 37 PL. DECIMALS XXX ± .005. 38 PL. DECIMALS XXX ± .005. 39 PL. DECIMALS XXX ± .005. 40 PL. DECIMALS XXX ± .005. 41 PL. DECIMALS XXX ± .005. 42 PL. DECIMALS XXX ± .005. 43 PL. DECIMALS XXX ± .005. 44 PL. DECIMALS XXX ± .005. 45 PL. DECIMALS XXX ± .005. 46 PL. DECIMALS XXX ± .005. 47 PL. DECIMALS XXX ± .005. 48 PL. DECIMALS XXX ± .005. 49 PL. DECIMALS XXX ± .005. 50 PL. DECIMALS XXX ± .005. 51 PL. DECIMALS XXX ± .005. 52 PL. DECIMALS XXX ± .005. 53 PL. DECIMALS XXX ± .005. 54 PL. DECIMALS XXX ± .005. 55 PL. DECIMALS XXX ± .005. 56 PL. DECIMALS XXX ± .005. 57 PL. DECIMALS XXX ± .005. 58 PL. DECIMALS XXX ± .005. 59 PL. DECIMALS XXX ± .005. 60 PL. DECIMALS XXX ± .005. 61 PL. DECIMALS XXX ± .005. 62 PL. DECIMALS XXX ± .005. 63 PL. DECIMALS XXX ± .005. 64 PL. DECIMALS XXX ± .005. 65 PL. DECIMALS XXX ± .005. 66 PL. DECIMALS XXX ± .005. 67 PL. DECIMALS XXX ± .005. 68 PL. DECIMALS XXX ± .005. 69 PL. DECIMALS XXX ± .005. 70 PL. DECIMALS XXX ± .005. 71 PL. DECIMALS XXX ± .005. 72 PL. DECIMALS XXX ± .005. 73 PL. DECIMALS XXX ± .005. 74 PL. DECIMALS XXX ± .005. 75 PL. DECIMALS XXX ± .005. 76 PL. DECIMALS XXX ± .005. 77 PL. DECIMALS XXX ± .005. 78 PL. DECIMALS XXX ± .005. 79 PL. DECIMALS XXX ± .005. 80 PL. DECIMALS XXX ± .005. 81 PL. DECIMALS XXX ± .005. 82 PL. DECIMALS XXX ± .005. 83 PL. DECIMALS XXX ± .005. 84 PL. DECIMALS XXX ± .005. 85 PL. DECIMALS XXX ± .005. 86 PL. DECIMALS XXX ± .005. 87 PL. DECIMALS XXX ± .005. 88 PL. DECIMALS XXX ± .005. 89 PL. DECIMALS XXX ± .005. 90 PL. DECIMALS XXX ± .005. 91 PL. DECIMALS XXX ± .005. 92 PL. DECIMALS XXX ± .005. 93 PL. DECIMALS XXX ± .005. 94 PL. DECIMALS XXX ± .005. 95 PL. DECIMALS XXX ± .005. 96 PL. DECIMALS XXX ± .005. 97 PL. DECIMALS XXX ± .005. 98 PL. DECIMALS XXX ± .005. 99 PL. DECIMALS XXX ± .005. 100 PL. DECIMALS XXX ± .005.	
HOME PRODUCTS INTERNATIONAL, INC. 4501 W. 47TH ST. MILWAUKEE, WI 53222 (733) 895-1000		PART NAME: LEG - SHORT		MATERIAL SPEC: 24 G.A. E.V. CRS TUBING	
RCS DATE: 08-26-03		DATE: 08-26-03		DATE: 08-26-03	
ISSUED:		DATE:		DATE:	
PART NO. B		SIZE B		REV. 1 OF 1	
EXP1050-7		REV. 1 OF 1		REV. 1 OF 1	











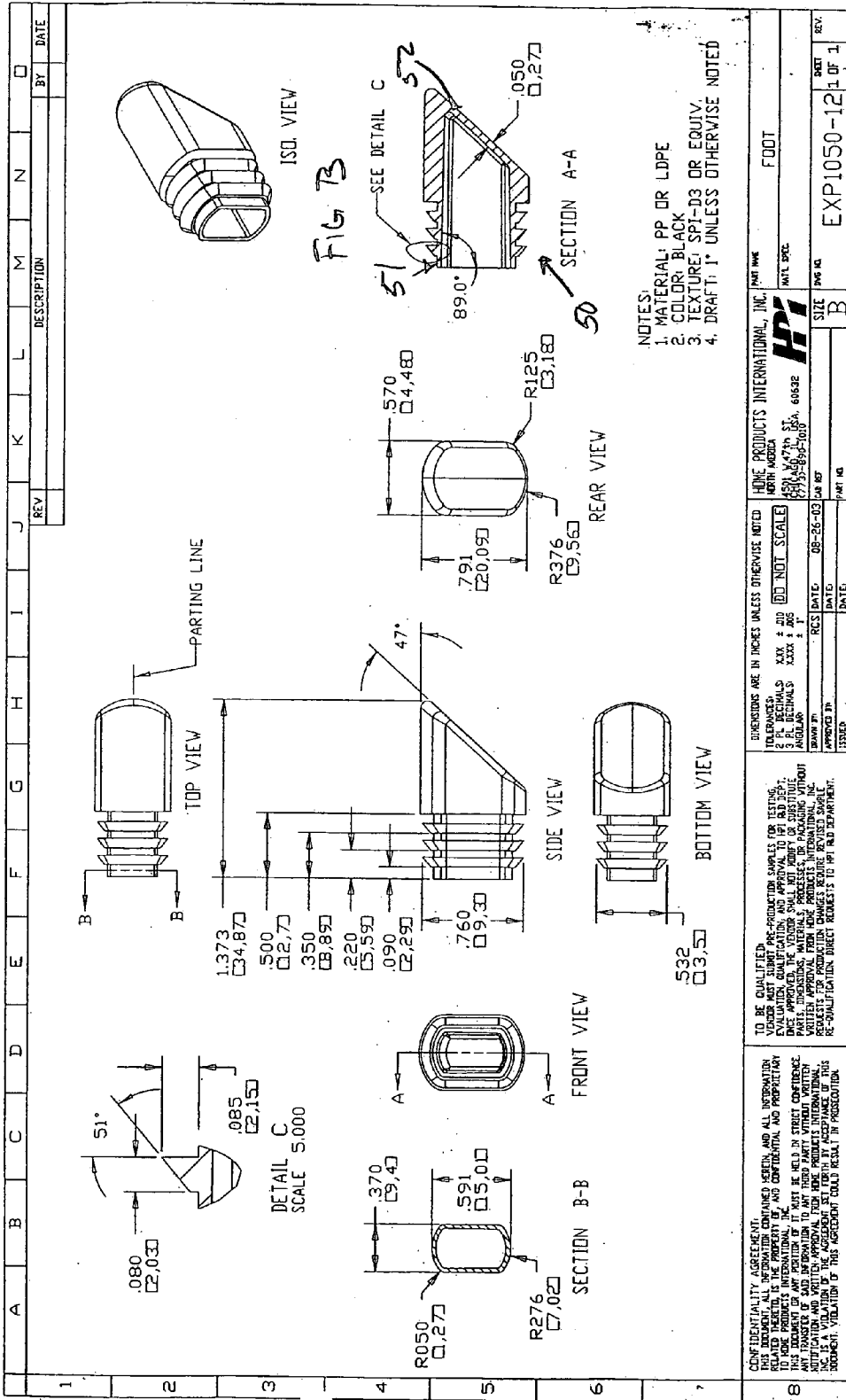
REV	DATE	BY

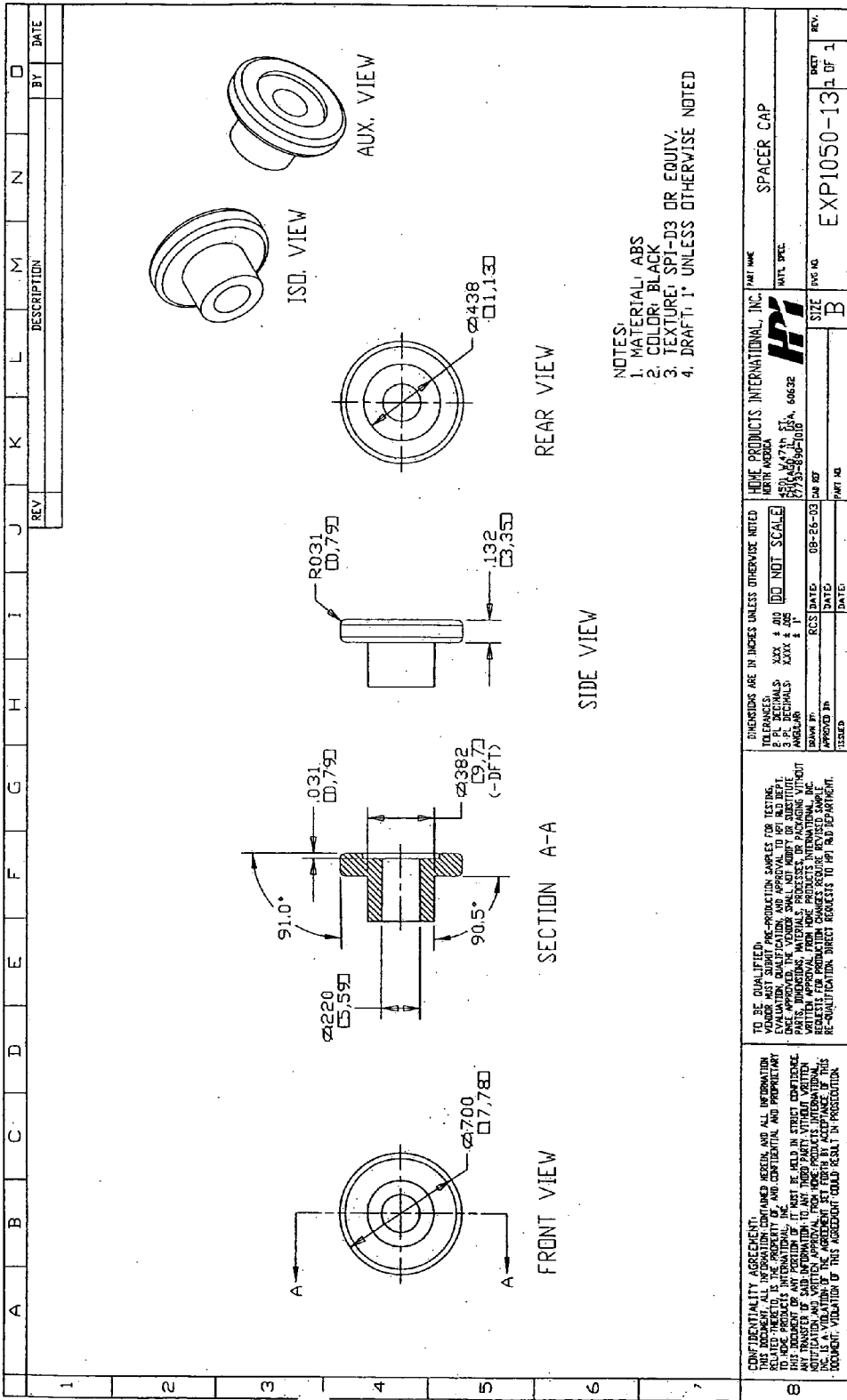
HOME PRODUCTS INTERNATIONAL, INC. MORRISVILLE, NC 27560	PART NAME END CLIP - LONG
DATE: 08/26/03 DRAWN BY: [UNRECOGNIZED] CHECKED BY: [UNRECOGNIZED]	PART SPEC
RCS: DATE: 08-26-03 DESIGNED BY: [UNRECOGNIZED]	SIZE B
APPROVED BY: [UNRECOGNIZED]	SHEET EXP1050-11 OF 1

**CONFIDENTIALITY AGREEMENT:**  
 THIS DOCUMENT AND ALL INFORMATION CONTAINED HEREIN, AND ALL INFORMATION RELATED THERETO, IS THE PROPERTY OF AND CONFIDENTIAL AND PROPRIETARY INFORMATION OF HOME PRODUCTS INTERNATIONAL, INC. IT IS TO BE KEPT IN STRICT CONFIDENCE, NOT REPRODUCED OR DISCLOSED TO ANY THIRD PARTY WITHOUT WRITTEN AUTHORIZATION AND WRITTEN APPROVAL FROM HOME PRODUCTS INTERNATIONAL, INC. ANY UNAUTHORIZED DISCLOSURE OF THIS INFORMATION TO ANY OTHER PERSON OR ENTITY WITHOUT THE WRITTEN CONSENT OF HOME PRODUCTS INTERNATIONAL, INC. IS STRICTLY PROHIBITED. VIOLATION OF THIS AGREEMENT COULD RESULT IN PROSECUTION.

**TO BE QUALIFIED:**  
 THE PRODUCTION SAMPLES FOR TESTING SHALL BE QUALIFIED AS SUCH BY THE QUALITY CONTROL DEPARTMENT. THE QUALIFICATION REQUESTS FOR PRODUCTION SAMPLES SHALL BE SUBMITTED TO THE QUALIFICATION DIRECT REQUESTS TO RPT R&D DEPARTMENT.



CONFIDENTIALITY AGREEMENT: THIS DOCUMENT, ALL INFORMATION CONTAINED HEREIN, AND ALL INFORMATION TO WHICH THIS DOCUMENT REFERS, IS UNCLASSIFIED AND CONFIDENTIAL AND PROPRIETARY TO HOME PRODUCTS INTERNATIONAL, INC. IT IS TO BE KEPT UNDER STRICT CONFIDENTIALITY AND NOT TO BE DISCLOSED TO ANY OTHER PARTY WITHOUT THE WRITTEN APPROVAL OF HOME PRODUCTS INTERNATIONAL, INC. IT IS A VIOLATION OF THIS AGREEMENT TO DISCLOSE OR TO ACCEPTANCE OF THIS DOCUMENT. A VIOLATION OF THIS AGREEMENT COULD RESULT IN PROSECUTION.



<p>CONFIIDENTIALITY AGREEMENT:                  THIS DOCUMENT CONTAINS ALL INFORMATION AND ALL INFORMATION RELATED HERETO IS THE PROPERTY OF, AND CONFIDENTIAL AND PROPRIETARY TO, HPM. IT IS TO BE KEPT IN STRICT CONFIDENCE AND NOT TO BE DISCLOSED OR REPRODUCED IN ANY MANNER WITHOUT THE WRITTEN AUTHORIZATION OF HPM. HPM PRODUCTS INTERNATIONAL, INC. ACCEPTS NO LIABILITY FOR ANY ERRORS OR OMISSIONS. HPM PRODUCTS INTERNATIONAL, INC. ACCEPTS NO LIABILITY FOR ANY ERRORS OR OMISSIONS. HPM PRODUCTS INTERNATIONAL, INC. ACCEPTS NO LIABILITY FOR ANY ERRORS OR OMISSIONS.</p>	<p>HPM PRODUCTS INTERNATIONAL, INC.                  HPM, INC.                  4501 W. 47th St., #60632                  Tulsa, OK 74137-4501                  TEL: 918-436-1010                  FAX: 918-436-1010</p> <p>DATE: 08-26-03                  DRAWN BY: [REDACTED]                  CHECKED BY: [REDACTED]                  APPROVED BY: [REDACTED]                  ISSUED: [REDACTED]</p>
<p>TO BE QUALIFIED RE-PRODUCTION SAMPLES FOR TESTING, EVALUATION, QUALIFICATION AND APPROVAL TO HPI AND DEPT. ONCE APPROVED, THE VENDOR SHALL NOT MODIFY OR SUBSTITUTE ANY DIMENSIONS OR MATERIALS FROM THE PRODUCTION SAMPLE WITHOUT APPROVAL FROM HPM PRODUCTS INTERNATIONAL, INC. RE-QUALIFICATION FOR PRODUCTION SAMPLES REQUIRE REVISED SAMPLE RE-QUALIFICATION. DIRECT REQUESTS TO HPI AND DEPARTMENT.</p>	<p>DIMENSIONS ARE IN INCHES UNLESS OTHERWISE NOTED.                  TOLERANCES:                  2 PL. DECIMALS XXX ± .00                  3 PL. DECIMALS XXXX ± .00                  DECIMALS XXXX ± .00</p> <p>DO NOT SCALE</p>
<p>HPM PRODUCTS INTERNATIONAL, INC.                  HPM, INC.                  4501 W. 47th St., #60632                  Tulsa, OK 74137-4501                  TEL: 918-436-1010                  FAX: 918-436-1010</p>	<p>DATE: 08-26-03                  DRAWN BY: [REDACTED]                  CHECKED BY: [REDACTED]                  APPROVED BY: [REDACTED]                  ISSUED: [REDACTED]</p>

<p>HPM PRODUCTS INTERNATIONAL, INC.                  HPM, INC.                  4501 W. 47th St., #60632                  Tulsa, OK 74137-4501                  TEL: 918-436-1010                  FAX: 918-436-1010</p>	<p>SPACER CAP</p>
<p>DATE: 08-26-03                  DRAWN BY: [REDACTED]                  CHECKED BY: [REDACTED]                  APPROVED BY: [REDACTED]                  ISSUED: [REDACTED]</p>	<p>DATE: 08-26-03                  DRAWN BY: [REDACTED]                  CHECKED BY: [REDACTED]                  APPROVED BY: [REDACTED]                  ISSUED: [REDACTED]</p>
<p>SIZE B</p>	<p>SIZE B</p>
<p>EXP1050-13</p>	<p>EXP1050-13</p>
<p>1 of 1</p>	<p>1 of 1</p>

**COLLAPSIBLE CLOTHES DRYING RACK**

**BACKGROUND OF THE INVENTION**

[0001] This invention relates to a collapsible clothes drying rack.

**SUMMARY OF THE INVENTION**

[0002] A collapsible clothes drying rack is disclosed herein. The details of the invention are set forth below in connection with the detailed description of the embodiments.

[0003] A better understanding of the present invention will be obtained from the following detailed descriptions and accompanying drawings, which set forth illustrative embodiments that are indicative of the various ways in which the principals of the invention may be employed.

**BRIEF DESCRIPTION OF THE DRAWINGS**

[0004] FIG. 1 is a perspective view of an embodiment of the present invention.

[0005] FIG. 2 is a front end view of the embodiment depicted in FIG. 1.

[0006] FIG. 3 is a perspective view of an embodiment of a second frame of the present invention.

[0007] FIG. 4 is a perspective view of an embodiment of a first frame of the present invention.

[0008] FIG. 5 is a perspective view of the tube end cap.

[0009] FIG. 6 is a side view of a tube end cap.

[0010] FIG. 7 is a perspective view of an end cap.

[0011] FIG. 8 is a perspective view of a short end clip.

[0012] FIG. 9 is a perspective view of a long end clip.

[0013] FIG. 10 is a perspective view of a spacer cap.

[0014] FIG. 11 is a top view of the present invention.

[0015] FIG. 12 is a side view of an alternate embodiment of the present invention.

**DETAILED DESCRIPTION OF THE DRAWINGS**

[0016] Turning now to the figures, where like reference numerals refer to like elements, there is illustrated in FIG. 1 an exemplary collapsible clothes drying rack 10 having frames 12 and 112. Frames 12 and 112 are collapsible between a folded position and an extended position. Frames 12 and 112 are mirror images of one another and are each mounted to and separated by a plurality of rods 90.

[0017] In the embodiment depicted in FIG. 4, frame 12 is comprised of a series of vertically-arrayed, "X"-shaped subassemblies 20, 30 and 40. Subassembly 20 is comprised of first member 21 and second member 22. First member 21 has first end 25 and second end 27, while second member 22 has first end 26 and second end 28. As shown, first ends 25 and 26 form subassembly first end 20A, while second ends 27 and 28 form subassembly second end 20B. First member 21 and second member 22 are rotatably joined at pivot point 23, which, in the depicted embodiment, is located at the approximate midpoint of both first member 21 and second

member 22. It will be appreciated that the depicted location of pivot point 23 is exemplary and not limiting.

[0018] In the depicted embodiment, foot 50 is engaged to each of second ends 27 and 28. Foot 50 comprises first end 51, which is selectively engaged to first member 21 or second member 22, and second end 52. Second end 52 of foot 50 is angled such that, when drying rack 10 is fully assembled and frame 12 is in the extended position, second end 52 of foot 50 is parallel with and engages the surface (not shown) that frame 12 is resting on.

[0019] Subassembly 30 is comprised of a structure that is similar to subassembly 20. Subassembly 30 comprises first member 31 and second member 32. First member 31 has first end 35 and second end 37, while second member 32 has first end 36 and second end 38. As shown, first ends 35 and 36 form subassembly first end 30A, while second ends 37 and 38 form subassembly second end 30B. First member 31 and second member 32 are rotatably joined at pivot point 33, which, in the depicted embodiment, is located at the approximate midpoint of both first member 31 and second member 32. It will be appreciated that the depicted location of pivot point 33 is exemplary and not limiting.

[0020] As shown in FIG. 4, subassembly second end 20B is pivotally attached to subassembly first end 30A. Specifically, first member 21 of subassembly 20 is pivotally engaged to second member 32 of subassembly 30 at rotation point 24. Rotation point 24 is located at first end 25 of first member 21, and second end 38 of second member 32. Similarly, second member 22 of subassembly 20 is rotatably engaged to first member 31 of subassembly 30 at rotation point 29. Rotation point 29 is located at first end 26 of second member 22, and second end 37 of first member 31. In this manner, rotation of first member 21 and second member 22 about pivot point 23 will cause first member 31 and second member 32 to rotate about pivot point 33.

[0021] As seen, the structure of subassembly 40 may be similar to both subassemblies 30 and 20. As depicted, subassembly 40 comprises first member 41 and second member 42. First member 41 has first end 45 and second end 47, while second member 42 has first end 46 and second end 48. As shown, first ends 45 and 46 form subassembly first end 40A, while second ends 47 and 48 form subassembly second end 40B. First member 41 and second member 42 are rotatably joined at pivot point 43, which, in the depicted embodiment, is located at the approximate midpoint of both first member 41 and second member 42. It will be appreciated that the depicted location of pivot point 43 is exemplary and not limiting.

[0022] As shown, subassembly second end 30B is pivotally attached to subassembly first end 40A. Specifically, first member 31 of subassembly 30 is pivotally engaged to second member 42 of subassembly 40 at rotation point 34. Rotation point 34 is located at first end 35 of first member 31, and second end 48 of second member 42. Similarly, second member 32 of subassembly 30 is rotatably engaged to first member 41 of subassembly 40 at rotation point 39. Rotation point 39 is located at first end 36 of second member 32, and second end 47 of first member 41. In this manner, rotation of first member 31 and second member 32 about pivot point 33, or the rotation of first member 21 and second member 22 about pivot point 23, will cause first member 41 and second member 42 to rotate about pivot point 43.

[0023] It will be appreciated that the depicted embodiment is illustrative only, and not limiting. For example, frame 12 may comprise only one subassembly, such as subassembly 20. Alternatively, frame 12 may comprise two subassemblies, such as subassemblies 20 and 40. As a further alternative, frame 12 may comprise more than three subassemblies, such as a subassembly 20, a plurality of subassemblies 30 and a subassembly 40. It will also be appreciated that frame 12 and frame 112 may be completely collapsible between an extended position and a collapsed position. As depicted, drying rack 10 may also be collapsible between an extended position and a collapsed position when assembled, as described more fully below.

[0024] As stated above, frames 12 and 112 are mirror images of one another. As such, the structure of frame 112 may be identical to frame 12, and will only be briefly described herein. For example, frame 112 may comprise a series of vertically-arrayed, "X"-shaped subassemblies 120, 130 and 140. Subassembly 120 is comprised of first member 121 and second member 122, rotatably joined at pivot point 123. Subassembly 130 is comprised of first member 131 and second member 132, rotatably joined at pivot point 133. Subassembly 140 is comprised of first member 141 and second member 142, rotatably joined at pivot point 143. Subassembly 120 is rotatably engaged to subassembly 130 at rotation points 124 and 129. Subassembly 130 is also rotatably engaged to subassembly 140 at rotation points 134 and 139.

[0025] As seen, for example, in FIG. 1, frame 12 also comprises locking arm 13, while frame 112 comprises locking arm 113. As shown in FIG. 4, locking arm 13 is pivotally connected to second member 42 at locking pivot point 71, which is located at first end 46 of second member 42. Locking arm 13 may be selectively engaged to first end 45 of first member 41. When engaged, locking arm 13 locks frame 12 in the extended position. Likewise, as shown in FIG. 3, locking arm 113 may be pivotally connected to second member 142 at locking pivot point 171, which is located at first end 146 of second member 142. Locking arm 113 may be selectively engaged to first end 145 of first member 141. When engaged, locking arm 113 locks frame 112 in the extended position. Locking arms 13 and 113 are described in detail below. However, it will be appreciated by those in the art that multiple methods of selectively engaging locking arms 13 and 113 to second members 42 and 142, respectively, are within the scope of the present invention.

[0026] As seen in FIG. 11, first members 21, 31 and 41, second members 22, 32, and 42 and locking arm 13 each comprise the same width, W1. Also, first members 21, 31 and 41 each lie in a common plane 81. Likewise, second members 22, 32 and 42 lie in a common plane 82, which is proximate to plane 81. Finally, locking arm 13 lies in a plane 83, which is proximate to plane 82. Thus, plane 82 is situated between planes 81 and 83. Frame 112 has an analogous structure, as depicted in FIG. 11. First members 121, 131 and 141, second members 122, 132, and 142 and locking arm 113 each comprise the same width, W2. Also, first members 121, 131 and 141 each lie in a common plane 181; second members 122, 132 and 142 lie in a common plane 182, which is proximate to plane 181; and locking arm 113 lies in a plane 183, which is proximate to plane 182 such that plane 182 is between planes 181 and 183. It will be appreciated that W1 may be equal to W2, or the two widths

may be different. Regardless, when rack 10 is assembled, with frame 12 opposed to frame 112, distance D1, which is the distance between planes 83 and 183, is smaller than distance D2, which is the distance between planes 82 and 182. Distance D2, in turn, is smaller than distance D3, which is the distance between planes 81 and 181.

[0027] To account for the differences in the distances, a plurality of short end clips 60 and long end clips 65 are attached to frames 12 and 112. As depicted in FIG. 8, each short end clip 60 comprises a first end 61, which is attached to one of frames 12 or 112, and a second end 62. As depicted in FIG. 9, each long end clip 65 comprises a first end 66, which is attached to one of frames 12 or 112, and a second end 67. A plurality of short end clips 60 may be engaged to each of locking arms 13 and 113, while a plurality of long end clips 65 may be engaged to each of subassemblies 20, 30, 40, 120, 130 and 140. As depicted, long end clips 66 may be attached at midpoints 23, 33, 43, 123, 133 and 143, as well as rotation points 24, 29, 34, 39, 124, 129, 134 and 139. However, it will be appreciated that long end clips 65 may be engaged to the subassemblies at any point, although if engaged at certain points, the long end clips 65 may prevent frames 12 and 112 from collapsing between the folded and extended positions. Additionally, each short end clip 60 engaged to locking arm 13 may be in a paired relationship with a short end clip 60 engaged to locking arm 113. Likewise, each long end clip 65 engaged to frame 12 may be in a paired relationship with a long end clip 65 engaged to frame 112.

[0028] When the short end clips 60 and long end clips 65 are engaged to frames 12 and 112, common plane 84 is formed by each of the second ends 62 and 67 of the short end clips 60 and long end clips 65 engaged to frame 12. Likewise, a common plane 184 is formed by each of the second ends 62 and 67 of the pluralities of short end clips 60 and long end clips 65 engaged to frame 112. When rack 10 is fully assembled, common planes 84 and 184 are separated by a distance D4.

[0029] As discussed above, each locking arm 13 and 113 selectively engages each first member 41 and 141, respectively. In the embodiment depicted, for example, in FIGS. 3 and 4, locking spacer cap 76, which is identical to an end cap 93, is attached to first member 41 at first end 45. Locking end clip 77, which may be identical to a short end clip 60, is attached to locking arm 13 at the end opposite of locking pivot point 71. In the depicted embodiment, locking end clip 77 and any short end clips 60 are attached to opposing sides of locking arm 13. In this way, locking spacer cap 76 cooperates with locking end clip 77 to selectively engage locking arm 13 with first member 41.

[0030] Likewise, locking spacer cap 176, which is identical to an end cap 93, is attached to first member 141 at first end 145. Locking end clip 177, which is identical to a short end clip 60, is attached to locking arm 113 at the end opposite of locking pivot point 171. In the depicted embodiment, locking end clip 177 and any short end clips 60 are attached to opposing sides of locking arm 113. In this way, locking spacer cap 176 cooperates with locking end clip 177 to selectively engage locking arm 113 with first member 141.

[0031] It will be appreciated that the description of locking arms 13 and 113 are exemplary and not limiting. For



example, FIG. 12 depicts an alternate embodiment of the present invention, where locking arms 13 and 113 engage second members 32 and 132, respectively. It will also be appreciated that the arrangement of short end clips 60 and long end clips 65 depicted in FIG. 12 may vary from the arrangement of short end clips 60 and long end clips 65 depicted in previous embodiments. For example, short end clips 60 may be engaged to each of the subassemblies of the first and second frame members, while a long end clip 65 may be engaged to second arms 42 and 142, proximate to locking pivot points 71 and 171. In this manner, each of the second ends of each of the short end clips and the long end clips engaged to the first frame member continue to form a common plane. Likewise, each of the second ends of each of the short end clips and the long end clips engaged to the second frame member continue to form a common plane.

[0032] In the depicted embodiment, a plurality of rods 90 extend between and are selectively secured to frames 12 and 112. For ease of manufacture and assembly, each rod 90 is the same length. Because of the identical lengths of the rods 90, each rod 90 may be connected to frames 12 and 112 at any corresponding point. Each rod 90 comprises a first end 91 and a second end 92.

[0033] End caps 93 are configured to alternatively selectively engage either a long end clip 65 or a short end clip 60. An end cap 93 is attached to each first end 91 and each second end 92 of each rod 90. A connecting element, such as notch 63, is formed at second end 62 of each short end clip 60. Each notch 63 is formed to cooperate with an end cap 93, so as to releasably secure an end cap 93 to the respective short end clip 60. Similarly, a connecting element, such as notch 68, is formed at each second end 67 of each long end clip 65. Each notch 68 is also formed to cooperate with an end cap 93 to releasably secure an end cap 93 to the respective long end clip 65. As depicted, each notch 63 and 68 may be formed to releasably secure an end cap 93 such that the corresponding rod 90 may be perpendicular to frames 12 or 112. In the depicted embodiment, each notch 63 and 68 is formed to provide an audible cue, such as a snapping sound, to inform the user as to when the end cap 93 is releasably secured within the corresponding notch. Because each notch 63 and 68 may releasably secure an end cap 93, and because each notch 63 and 68 lie in respective planes 84 and 184, thus separated by a common distance D4, any rod 90 may engage any pair of short end clips 60 or any pair of long end clips 65.

[0034] While specific embodiments of the invention have been described in detail, it will be appreciated by those skilled in the art that various modifications and alternatives to those details could be developed in light of the overall teachings of the disclosure. Accordingly, the particular arrangement disclosed is meant to be illustrative only and not limiting as to the scope of the invention which is to be given the full breadth of the appended claims and any equivalents thereof.

What is claimed is:

1. A collapsible clothes drying rack comprising:

a first frame member collapsible between a folded position and an extended position, the first frame member comprising a first locking arm engaged thereto;

a plurality of rods, wherein each rod is of equal length and comprises a first end and a second end, wherein the first end of each rod is selectively engaged to either the first frame member or the first locking arm; and

a second frame member collapsible between a folded position and an extended position, the second frame member comprising a second locking arm engaged thereto, wherein the second end of each of rod is selectively engaged to either the second frame member or the second locking arm.

2. The collapsible clothes drying rack as set forth in claim 1, further comprising a plurality of long end clips engaged to the first frame member, wherein each of the long end clips is releasably secured to the first end of one of the plurality of rods such that the rod is generally perpendicular to the first frame member.

3. The collapsible clothes drying rack as set forth in claim 2, further comprising a plurality of short end clips engaged to the first locking arm, wherein each of the short end clips is releasably secured to the first end of one of the plurality of rods such that the rod is generally perpendicular to the first frame member.

4. The collapsible clothes drying rack as set forth in claim 1, further comprising a plurality of long end clips engaged to the second frame member, wherein each of the long end clips is releasably secured to the second end of one of the plurality of rods such that the rod is generally perpendicular to the second frame member.

5. The collapsible clothes drying rack as set forth in claim 4, further comprising a plurality of short end clips engaged to the second locking arm, wherein each of the short end clips is releasably secured to the second end of one of the plurality of rods such that the rod is generally perpendicular to the second frame member

6. A collapsible clothes drying rack comprising:

a first frame member collapsible between a folded and an extended position, the first frame member comprising a first series of vertically-arrayed, generally "X"-shaped subassemblies, wherein each subassembly comprises a first arm and a second arm, rotatably joined at a pivot point, and wherein each of the subassemblies in the first series is pivotably attached to at least one vertically adjacent subassembly;

a first locking arm rotatably engaged to the first arm of one of the first frame member's subassemblies;

a plurality of rods, wherein each rod is of equal length and comprises a first end, selectively engaged to the first frame member, and a second end;

a second frame member collapsible between a folded position and an extended position, wherein the second frame member is selectively engaged to the second end of each of the plurality of rods, the second frame member comprising a second series of vertically-arrayed, generally "X"-shaped subassemblies, wherein each subassembly of the second series comprises a first arm and a second arm, rotatably joined at a pivot point, and wherein each of the subassemblies in the second series is rotatably attached at least one of its extremities to a vertically adjacent subassembly; and

a second locking arm rotatably engaged to the first arm of one of the second frame member's subassemblies;

wherein the plurality of rods maintains each frame member in a spaced, parallel relationship in both the extended position and the folded position

7. The collapsible clothes drying rack as set forth in claim 6, wherein the first locking arm is rotatably engaged to the uppermost subassemblies of the first frame member, and the second locking arm is rotatably engaged to the uppermost subassembly of the second frame member.

8. The collapsible clothes drying rack as set forth in claim 7, further comprising a plurality of long end clips engaged to each of the subassemblies of each of the frame members and a plurality of short end clips engaged to each locking arm.

9. The collapsible clothes drying rack as set forth in claim 8, wherein each of the short end clips attached to the first locking arm is in a paired relationship with a corresponding short end clip attached to the second locking arm.

10. The collapsible clothes drying rack as set forth in claim 4, wherein each of the long end clips attached to the subassemblies of the first frame member is in a paired relationship with a corresponding long end clip attached to the subassemblies of the second frame member.

11. The collapsible clothes drying rack as set forth in claim 10, further comprising an end cap attached at the first end and the second end of each rod, wherein each end cap is formed to cooperate with a short end clip or long end clip such that any rod may be releasably secured to any pair of short end clips or long end clips.

12. A collapsible clothes drying rack comprising:

a first frame member comprising:

at least one generally "X"-shaped subassembly;

a plurality of long end clips attached to each of the at least one subassembly of the first frame member;

a first locking arm attached to the at least one subassembly; and

a plurality of short end clips attached to the first locking arm;

a second frame member, wherein the second frame member is parallel to the first frame member and comprises:

at least one generally "X"-shaped subassemblies;

a plurality of long end clips attached to each of the at least one subassembly of the second frame member;

a second locking arm attached to the at least one subassembly; and

a plurality of short end clips attached to the second locking arm; and

a plurality of rods, wherein each rod is of equal length and comprises a first end, selectively engaged to either the long end clips attached to the at least one subassembly of the first frame member or the short end clips attached to the first locking arm, and a second end, selectively engaged to either the long end clips attached to the at least one subassembly of the second frame member or the short end clips attached to the second locking arm.

13. The collapsible clothes drying rack as set forth in claim 12, further comprising an end cap formed on the first end and on the second end of each rod, wherein each end cap engages either a short end clip or a long end clip such that

the rod is oriented perpendicular to both the first frame member and the second frame member.

14. The collapsible clothes drying rack as set forth in claim 12, wherein each of the short end clips attached to the first locking arm is in a paired relationship with a short end clip attached to the second locking arm.

15. The collapsible clothes drying rack as set forth in claim 12, wherein each of the long end clips attached to the at least one subassembly of the first frame member is in a paired relationship with a long end clip attached to the at least one subassembly of the second frame member.

16. The collapsible clothes drying rack as set forth in claim 12, wherein the first frame member comprises a plurality of generally "X"-shaped subassemblies.

17. The collapsible clothes drying rack as set forth in claim 16, wherein the second frame member comprises a plurality of generally "X"-shaped subassemblies.

18. The collapsible clothes drying rack as set forth in claim 12, wherein the first frame member and the second frame member are collapsible between an extended position and a collapsed position.

19. A collapsible clothes drying rack comprising:

a first frame member collapsible between a collapsed position and an extended position, the first frame member comprising:

at least one long end clip having a first end and a second end, wherein the first end is engaged to the first frame member and the second end forms a long end clip connecting element; and

at least one short end clip having a first end and a second end, wherein the first end is engaged to the first frame member and the second end forms a short end clip connecting element;

wherein the second end of the at least one short end clip engaged to the first frame member lies in a common plane with the second end of the at least one long end clip engaged to the first frame member;

a second frame member collapsible between a collapsed position and an extended position, the second frame member comprising:

at least one long end clip having a first end and a second end, wherein the first end is engaged to the second frame member and the second end forms a long end clip engagement element; and

at least one short end clip having a first end and a second end, wherein the first end is engaged to the second frame member and the second end forms a short end clip engagement element;

wherein the second end of the at least one short end clip engaged to the second frame member lies in a common plane with the second end of the at least one long end clip engaged to the second frame member; and

a plurality of rods positioned between and selectively engaged to the first frame member and the second frame member;

20. The collapsible clothes drying rack as set forth in claim 19, wherein each of the plurality of rods comprises a first end and a second end, wherein the first end of each rod alternatively engages the long end clip engagement element

or the short end clip engagement element formed on the at least one long end clip and the at least one short end clip engaged to the first frame member, and wherein the second end of each rod alternatively engages the long end clip engagement element or the short end clip engagement element formed on the at least one long end clip and the at least one short end clip engaged to the second frame member.

**21.** The collapsible clothes drying rack as set forth in claim 20, wherein the first frame member further comprises a first locking mechanism.

**22.** The collapsible clothes drying rack as set forth in claim 21, wherein the second frame member further comprises a second locking mechanism.

**23.** The collapsible clothes drying rack as set forth in claim 22, wherein the at least one short end clip engaged to the first frame member is located on the first locking mechanism.

**24.** The collapsible clothes drying rack as set forth in claim 23, wherein the at least one short end clip engaged to the second frame member is located on the second locking mechanism.

**25.** The collapsible clothes drying rack as set forth in claim 24, wherein a first sound is produced when the first end of any of the plurality of rods engages either the long end clip engagement element or the short end clip engagement element, and wherein a second sound is produced when the second end of any of the plurality of rods engages either the long end clip engagement element or the short end clip engagement element.

**26.** The collapsible clothes drying rack as set forth in claim 25, wherein the first sound is the same as the second sound.

\* \* \* \* \*