

Jan. 23, 1940.

J. R. HALL ET AL

2,188,292

ELECTRIC TARGET MACHINE WITH REVERSING TARGET

Filed Aug. 25, 1939

7 Sheets-Sheet 1

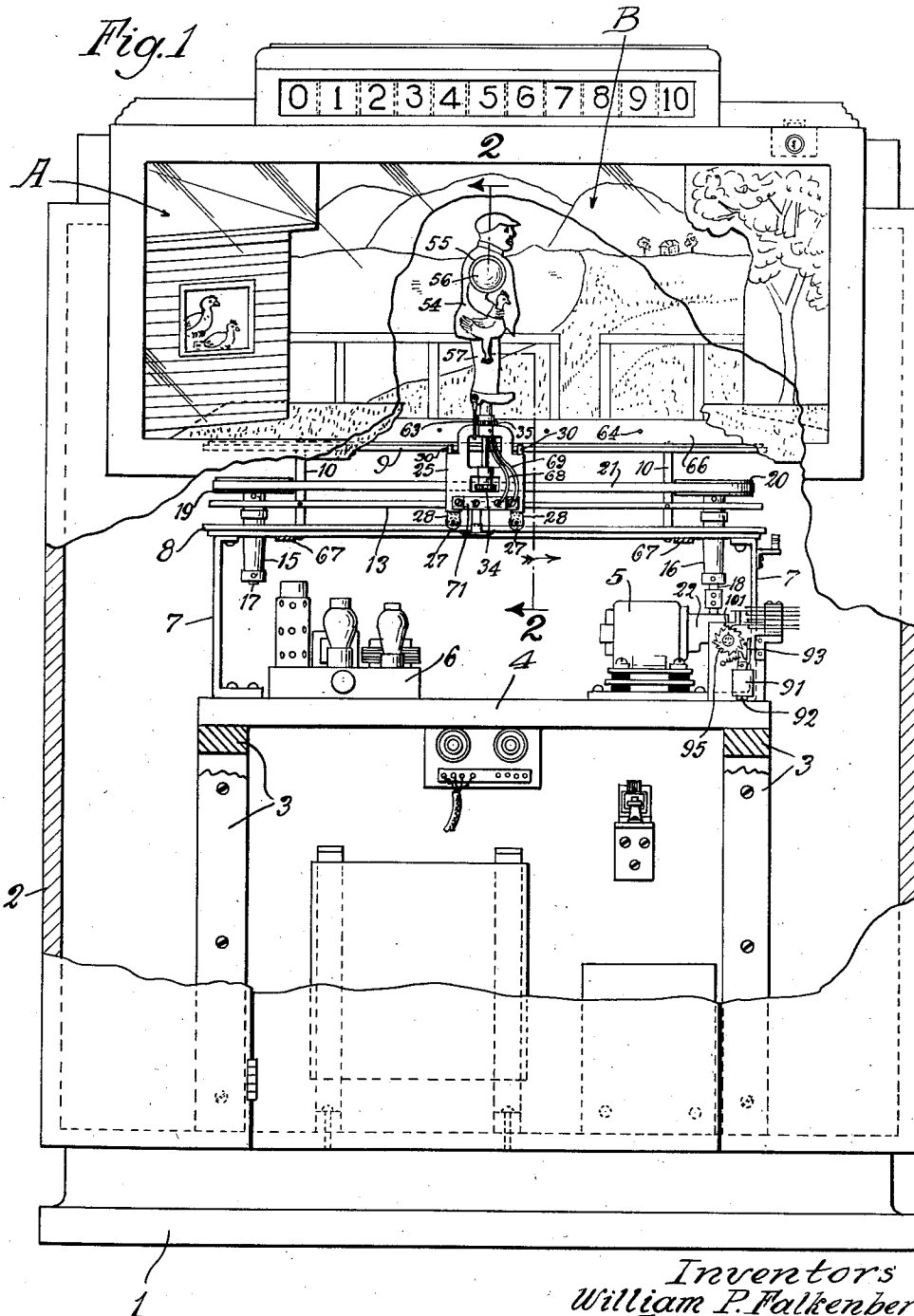

Inventors
William P. Falkenberg
Jawn R. Hall
by *Robert Hunter*
Attorneys

Jan. 23, 1940.

J. R. HALL ET AL

2,188,292

ELECTRIC TARGET MACHINE WITH REVERSING TARGET

Filed Aug. 25, 1939

7 Sheets—Sheet 2

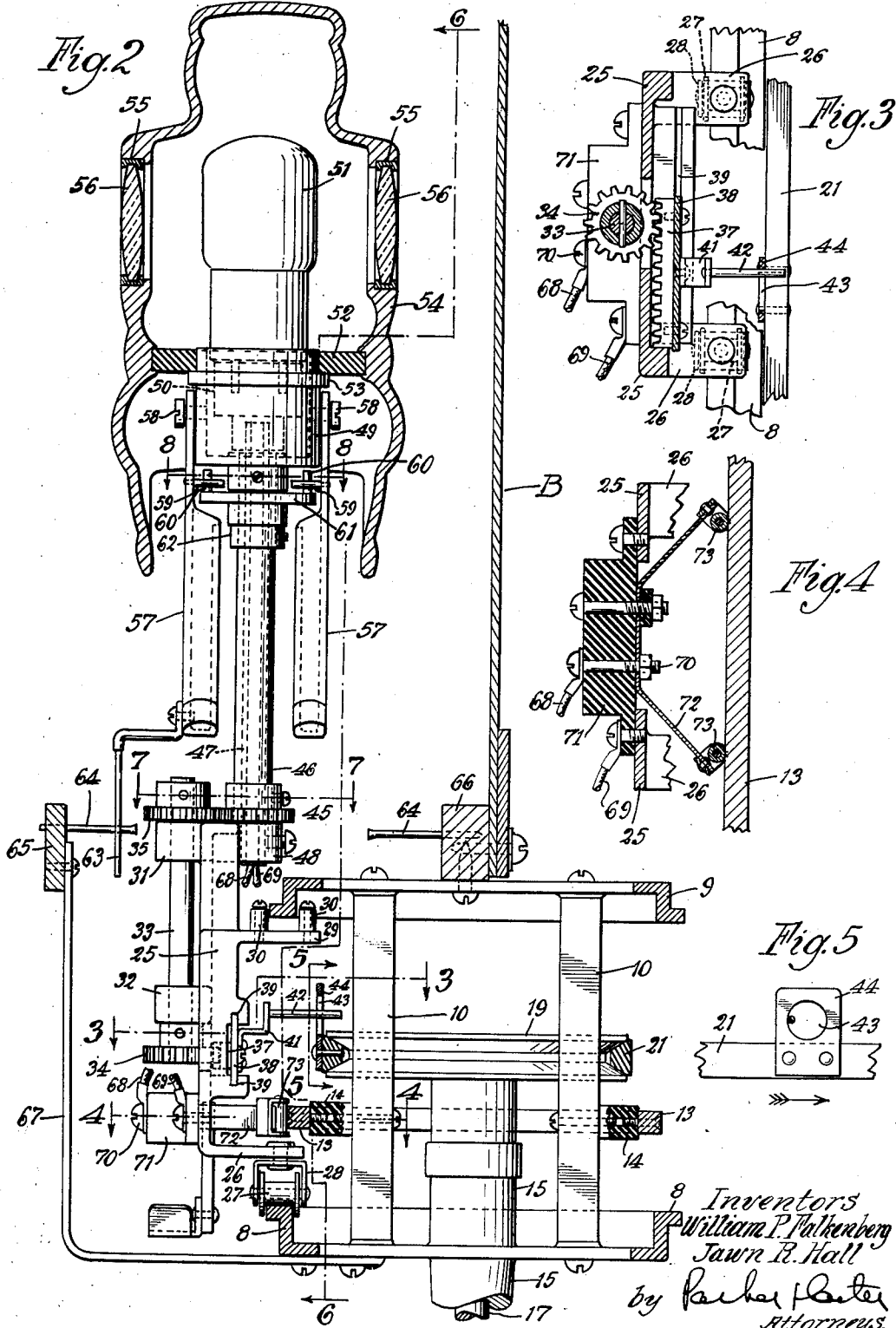

8 Inventors
William P. Walkerberg
Jawn B. Hall
by Fisher Porter
attorneys.

Jan. 23, 1940.

J. R. HALL ET AL

2,188,292

ELECTRIC TARGET MACHINE WITH REVERSING TARGET

Filed Aug. 25, 1939

7 Sheets-Sheet 3

Fig. 6

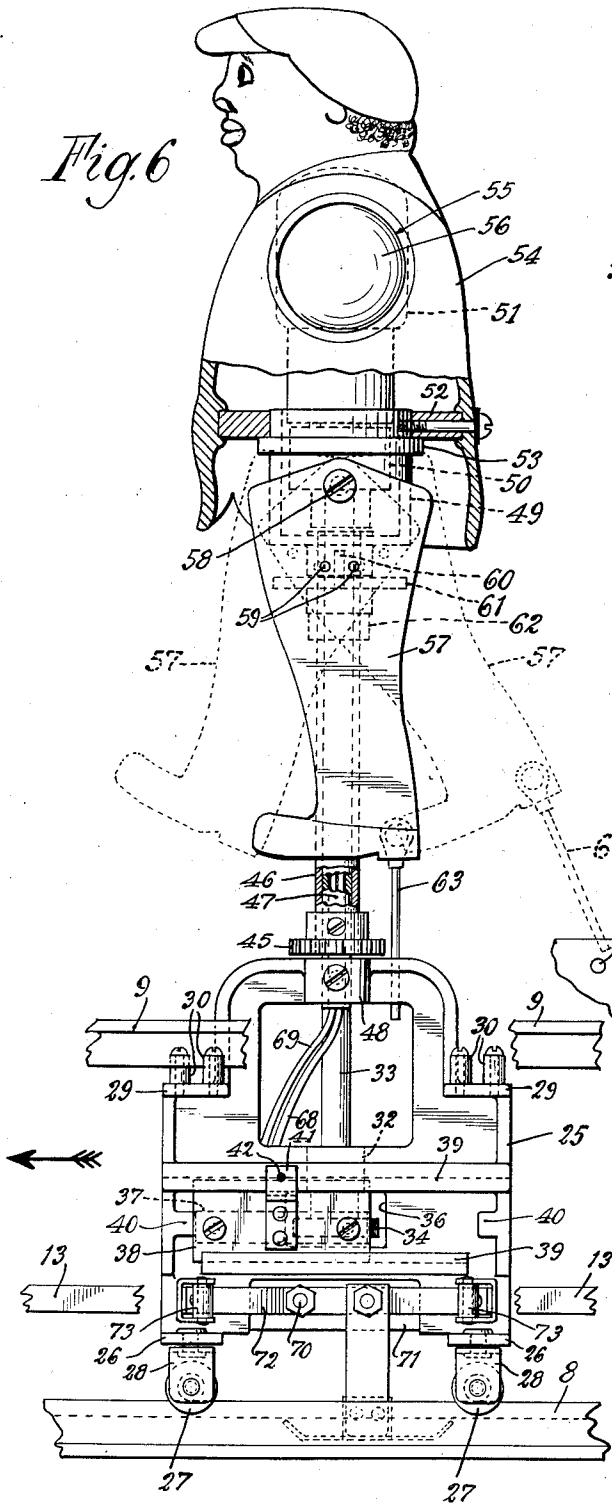

Fig. 7

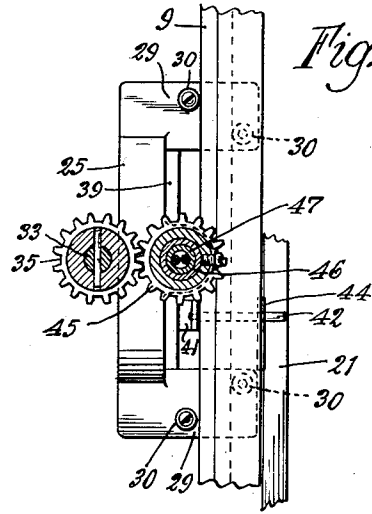
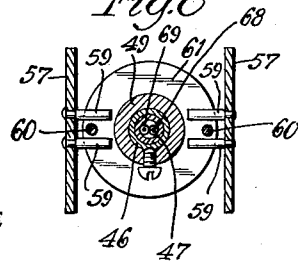

Fig. 8



Inventors
William P. Falkenberg
Jawn R. Hall
by *Loche Patz*
Attorneys.

Jan. 23, 1940.

J. R. HALL ET AL

2,188,292

ELECTRIC TARGET MACHINE WITH REVERSING TARGET

Filed Aug. 25, 1939

7 Sheets-Sheet 4

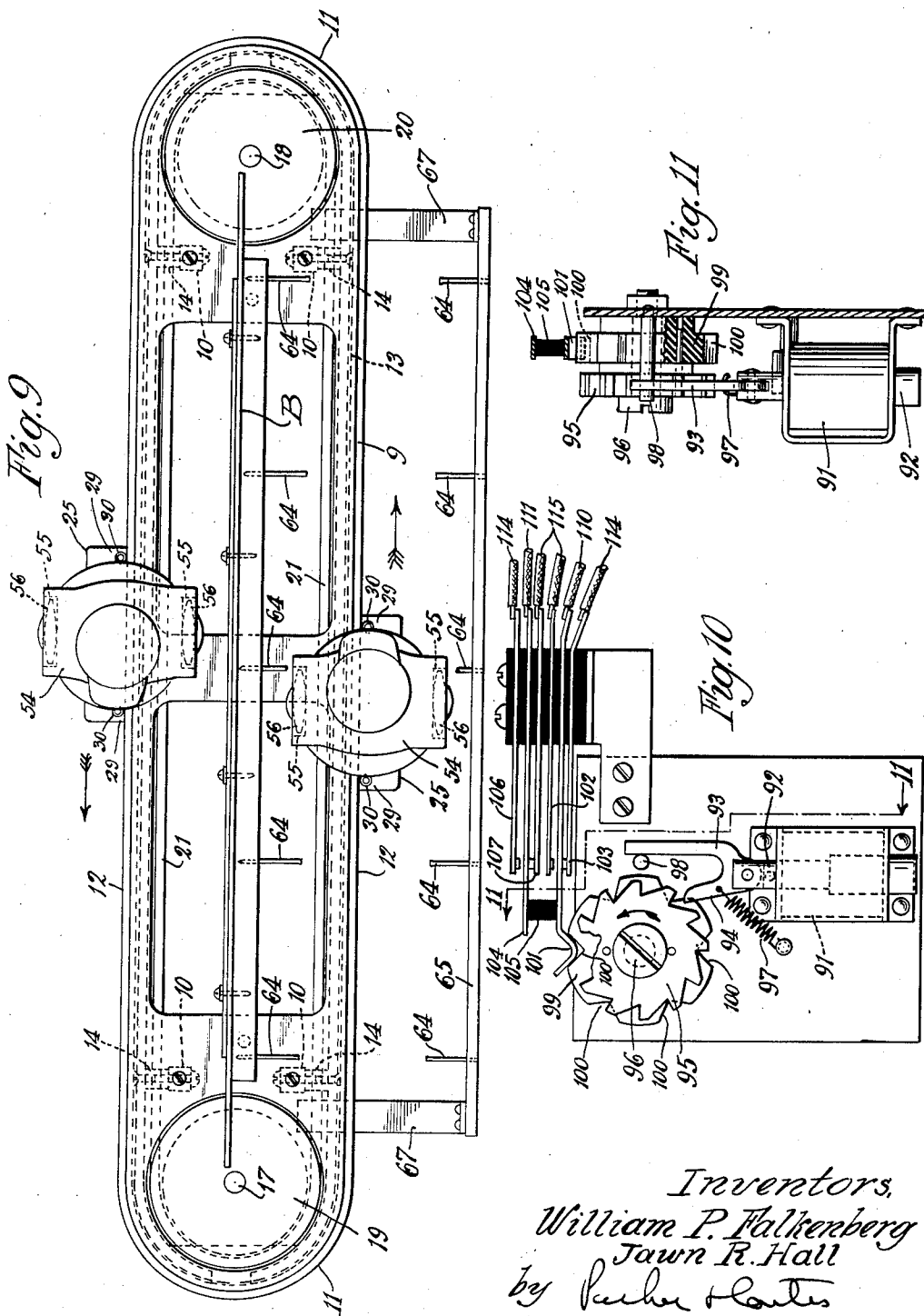

Inventors,
William P. Falkenberg
Jawn R. Hall
by Parker & Hester
Attorneys

Jan. 23, 1940.

J. R. HALL ET AL

2,188,292

ELECTRIC TARGET MACHINE WITH REVERSING TARGET

Filed Aug. 25, 1939

7 Sheets-Sheet 5

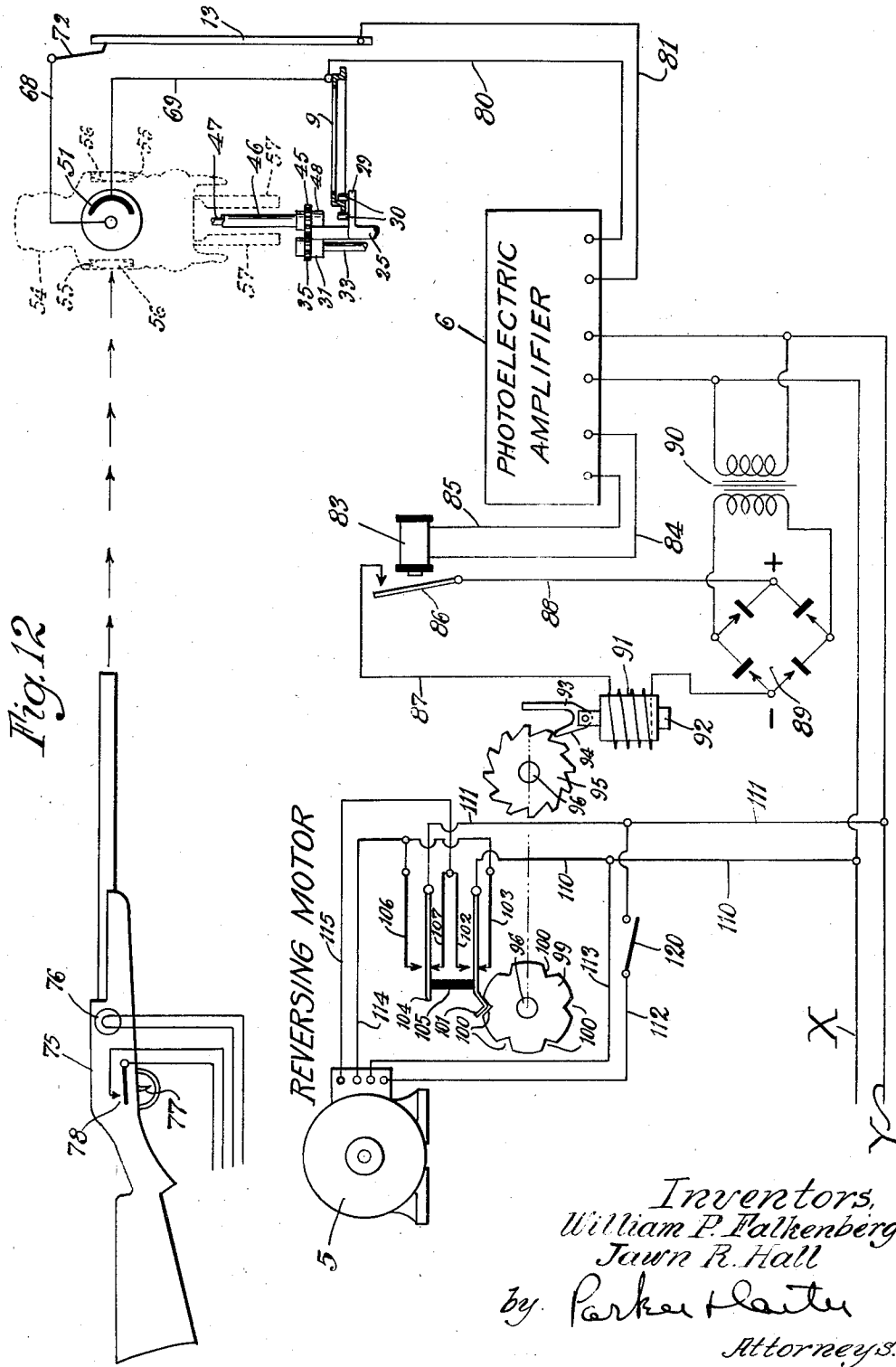

Jan. 23, 1940.

J. R. HALL ET AL

2,188,292

ELECTRIC TARGET MACHINE WITH REVERSING TARGET

Filed Aug. 25, 1939

7 Sheets—Sheet 6

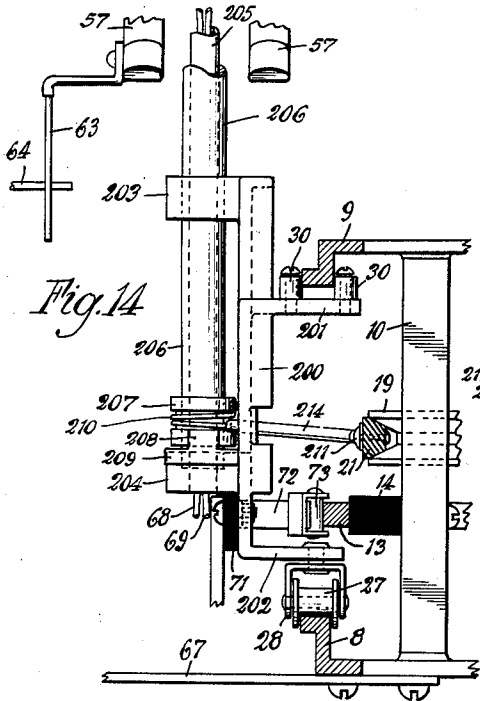

Fig. 14

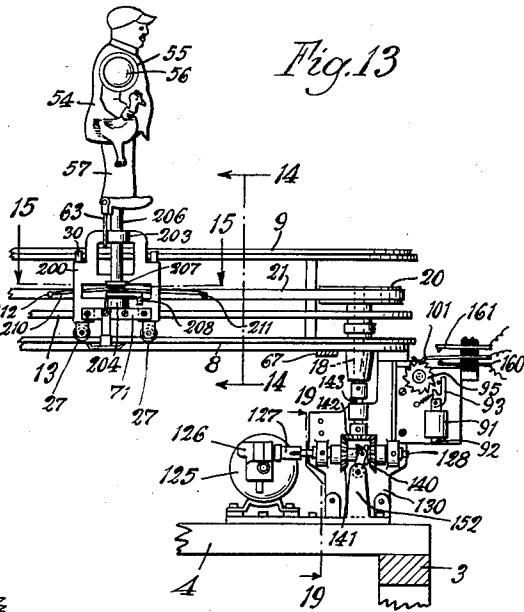

Fig. 13

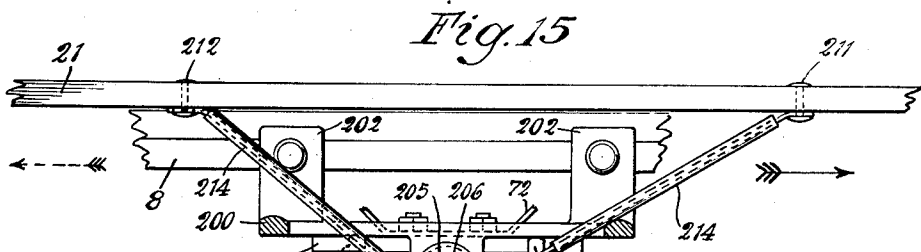

Fig. 15

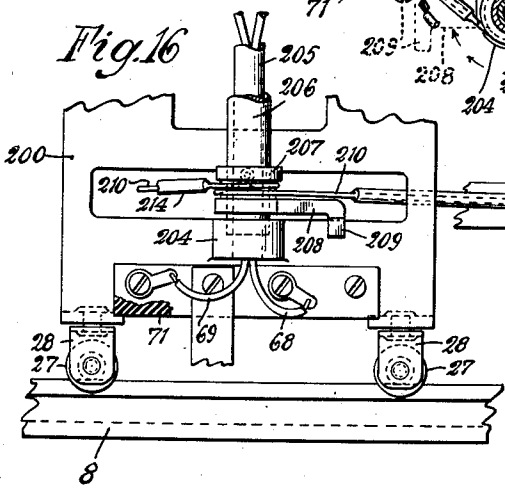

Fig. 16

Inventors
William P. Falkenberg
Joun R. Hall
by Parker Slater
Attorneys.

Jan. 23, 1940.

J. R. HALL ET AL

2,188,292

ELECTRIC TARGET MACHINE WITH REVERSING TARGET

Filed Aug. 25, 1939

7 Sheets-Sheet 7

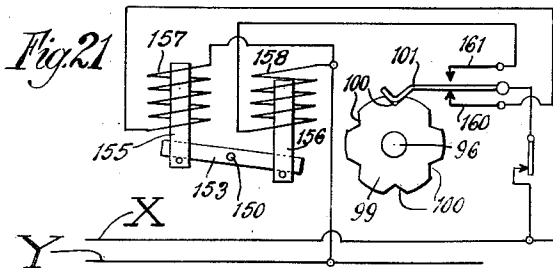
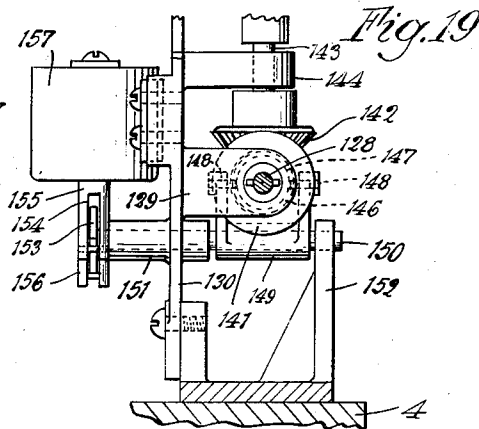
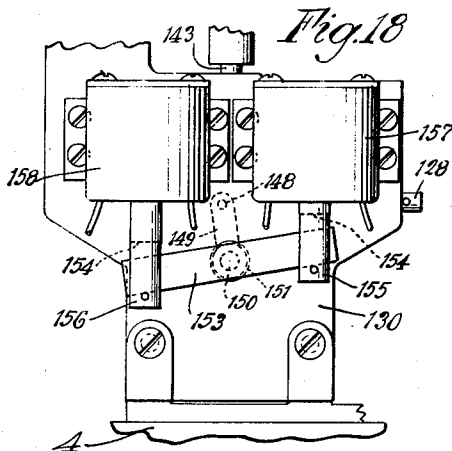
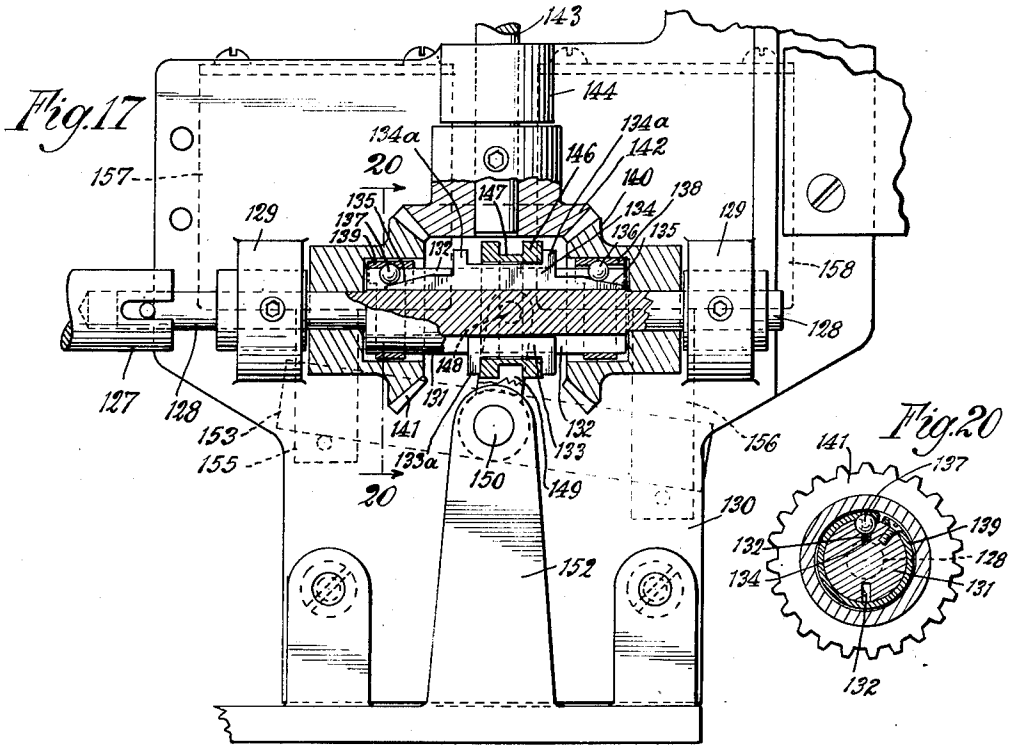

Inventors
William P. Falkenberg
Jawn R. Hall
by *Pecker Foster*
Attorneys

UNITED STATES PATENT OFFICE

2,188,292

ELECTRIC TARGET MACHINE WITH REVERSING TARGET

Jawn R. Hall and William P. Falkenberg, Los Angeles, Calif., assignors to Rayolite Rifle Range Company, Chicago, Ill., a corporation of Oklahoma

Application August 25, 1939, Serial No. 291,858

20 Claims. (Cl. 273—105.2)

Our invention relates to an improvement in electric target rifle ranges and has for one purpose the provision of an improved target.

Another purpose is the provision of a target, for use in connection with target guns shooting a flash of light, which is normally moved in one direction and which reverses its direction of movement when struck by a flash of light from the gun.

Another purpose is the provision of improved means for reversing the movement of the target actuating motor in response to a hit against the target.

Another purpose is the provision of an improved target structure which reverses when its direction of movement changes.

Other purposes will appear from time to time in the course of the specification and claims.

We illustrate our invention more or less diagrammatically in the accompanying drawings wherein:

Fig. 1 is a front elevation with parts broken away;

Fig. 2 is a section on an enlarged scale along the line 2—2 of Fig. 1;

Fig. 3 is a section on the line 3—3 of Fig. 2;

Fig. 4 is a section on the line 4—4 of Fig. 2;

Fig. 5 is a section on the line 5—5 of Fig. 2;

Fig. 6 is a section on the line 6—6 of Fig. 2;

Fig. 7 is a section on the line 7—7 of Fig. 2;

Fig. 8 is a section on the line 8—8 of Fig. 2;

Fig. 9 is a plan view of the target structure;

Fig. 10 is a front elevation of part of the reversing mechanism;

Fig. 11 is a section on the line 11—11 of Fig. 10; Fig. 12 is a wiring diagram;

Fig. 13 is a partial view of the structure shown in Fig. 1, illustrating a modification;

Fig. 14 is a section on the line 14—14 of Fig. 13;

Fig. 15 is a section on the line 15—15 of Fig. 13;

Fig. 16 is an enlarged view of part of the structure shown in Fig. 13;

Fig. 17 is an enlarged view of the reversing means shown in Fig. 13, with parts in vertical section;

Fig. 18 is a rear elevation on a reduced scale of part of the structure shown in Fig. 17;

Fig. 19 is a section on the line 19—19 of Fig. 13;

Fig. 20 is a section on the line 20—20 of Fig. 17;

Fig. 21 is a partial showing of a modified portion of the wiring diagram.

Like parts are indicated by like characters throughout the specification and drawings.

Referring to the drawings, 1 generally indicates any suitable base upon which the cabinet structure 2 is mounted. Mounted on the base and within the cabinet structure is a framework generally indicated as 3 which supports a platform 4 upon which is mounted any suitable re-

versible motor 5. 6 is an amplifier, the details of which do not of themselves form part of the present invention.

Mounted upon the platform 4, as upon supports 7, is a track structure which includes a lower track member 8 and an upper track member 9, the two track members being supported upon supporting spacing members 10 and forming closed loops as shown in Fig. 9 with arcuate end portions 11 and horizontal rectilinear parallel connecting portions 12. A third rail 13 is mounted upon the supports 10 upon insulating blocks 14 and conforms in general to the location of the tracks 8, 9.

Formed integrally or positioned with relation to the bottom rail 8 are fixed vertical sleeves 15, 16 in which are rotatable shafts 17, 18 which carry at their upper ends pulleys 19, 20 about which passes the belt 21. The shaft 18, shown at the right hand side of the structure as shown in Fig. 2, is connected by any suitable drive means, gear reduction or the like, diagrammatically indicated as 22 with the motor 5 whereby, when the motor is actuated, the belt 21 is driven.

Mounted for movement upon the tracks 8, 9 is a carriage frame generally indicated as at 25. It has offset portions 26 carrying rollers 27 engaging and resting upon the track 8. The rollers are provided with swivel connections 28 to permit the carriage to ride around arcuate end portions 11 of the track structure. The upper portion of the carriage frame 25 has offset ears 29, each one of which carries a pair of vertically axised rollers 30, somewhat offset and engaging opposite sides of the lower portion of the upper track 9. The offset relationship of the rollers or pins 30, as shown for example in Fig. 7, permits the carriage to ride around the arcuate track sections 11 without cramping or being slowed down.

Journalled in the carriage frame 25, as in the bearings 31, 32 is the vertical shaft 33 having a bottom gear 34 and a top gear 35. The bottom gear 34 extends through a slot 36 and meshes with a rack 37 mounted on a slide 38 slidable in guides 39 of the carriage member 25. Abutment stops 40 limit its movement in each direction.

A bracket 41 on the slide 38 carries an outwardly extending pin 42 which penetrates an aperture 43 of substantially greater diameter. This aperture is located in an upstanding lug 44 mounted on the belt 21. The upper gear 35 meshes with a gear 45 on the upstanding sleeve 46. The sleeve 46 in turn is journaled on an inner sleeve 47 which is fixed on a boss 48 mounted on or forming part of the carriage structure 25. The outer sleeve 46 carries at its upper end a cup-shaped member 49. The inner fixed sleeve 47 extends upwardly into the cup-shaped member and carries a socket 50 for the photo-

electric cell 51, the details of which do not of themselves form part of the present invention.

52 indicates a ring seated on the circumferential flange 53 of the cup structure 49. 52 in turn carries an outer shell or body generally indicated as at 54 which may for example simulate a negro carrying a chicken, or any other suitable design. It is apertured at each side as at 55 and any suitable lenses 56 may be employed in order to direct light against the light sensitive cell 51 when the electric light flash gun below described is properly aimed.

Hinged to the cup-shaped member 49 are a pair of legs generally indicated as 57. Each such leg is pivoted as at 58 and carries two pins 59 between which are positioned upstanding pins 60 on a rotatable disc or collar 61, which is loosely mounted on the outer sleeve 46 and which is supported by any suitable collar 62. One of the legs 57 carries a depending arm 63 which may engage pins 64 on bars 65, 66 located at opposite sides of the forward track of the track structure. The bar 65 may be held by any suitable bracket 67.

It will be understood that the target structure is reversible and when the housing 54 is faced in and is traveling in one direction, the member 63 engages one set of pins 64, whereas when the device is faced in and is traveling in the opposite direction, it engages the other set of pins 64 and causes a swinging of the legs which simulates a walking or running movement. The pins 64 may be spaced sufficiently close together along the path of movement of the target to keep the legs swinging to simulate a natural walking or running movement.

It will be understood that in the position of the parts as shown in Fig. 6, the target is traveling in the direction of the arrow. If the motor 5 is reversed and the direction of movement is reversed, then the reversal of movement, with a consequent reversal in the driving direction of the belt 21, will cause the member 38 to slide in the guides 39 as far as the opposite stop 40 will permit. This in turn will cause the rack 37 to rotate the gear 34 and will thereby rotate through the gears 35 and 45 the outer sleeve 46. This will turn the housing 54 around to face in the opposite direction, so that the target figure or housing 54 always appears to be moving in the proper direction to simulate walking or running on the part of the miniature figure which it forms.

It will be understood that any suitable wiring connections may be employed. We show for example wires 68, 69 in circuit with the photo cell 51. Wire 69 is grounded on the carriage structure whereas the wire 68 is secured to any suitable binding post 70 mounted in any suitable block of insulating material 71. By means of the spring 72 and the rollers or contacts 73 it connects with the third rail 13.

Any suitable gun or electric flash light means may be employed. We illustrate in the wiring diagram for example a gun structure generally indicated as 75 in which is an electric light source 76, a trigger 77, and a trigger switch 78. It will be understood that in response to a pull of the trigger 77 and a closure of the switch 78, any circuit, the details of which do not form part of the present invention, causes the light source 76 to emit a flash of light which, if the operator aims correctly, will strike the photo cell 51.

Any suitable coil control mechanism, if de-

sired, may be employed, and the number of shots available for a single coin may be limited. However, these features do not of themselves form part of the present invention and are not herein described in detail.

We illustrate, however, means for reversing the movement of the target structure in response to every hit so that the negro, if hit, may reverse his direction of movement. It will be understood, of course, that the housing 54 may simulate a negro, a hen house being illustrated at A in Fig. 1. As soon as the target is initially moved, with the negro moving toward the hen house, a successful hit will cause him to reverse his direction of movement and leave the hen house. This of course is merely one example of a practical use of our invention.

Any desired number of individual targets may be employed and in Fig. 9 we illustrate two. It will be understood that the rear scenery panel B masks the movements of the targets on the rear turn or stretch of the track portions. If no hit is scored, the targets keep moving uniformly in the same direction and reverse their movement only if struck.

Referring in greater detail to the reversing mechanism and wiring diagram, illustrated in Fig. 12, 80 is the ground connection which is in circuit with the line 69 and 81 is a conductive connection from the third rail 13. 6 indicates a photoelectric amplifier thus put in circuit with the photo cell 51. When the photo cell 51 is struck by a flash of light from the electric lamp 76 of the gun 75, the photoelectric amplifier 6 energizes the photoelectric relay 83 through a circuit including the lines 84 and 85. The relay switch 86 then closes a circuit including the lines 87 and 88. 89 generally indicates a rectifier energized by the transformer 90. 91 is a solenoid having an armature 92 having a hinged fork 93 including a dog portion 94 opposed to a ratchet wheel 95 on a shaft 96. 97 is a spring normally holding the dog 94 in the position in which it is shown in Fig. 10, with the long arm of the fork 93 in contact with the fixed pin 98.

When the photo cell 51 is struck, the solenoid 91 is energized and imparts an upward movement to the armature which moves the dog 94 into contact with one of the teeth of the ratchet wheel 95. This rotates the ratchet one step. Held against movement in relation to the ratchet is the disc 99 of insulating material which is provided with peripheral notches 100. There is one notch for every two teeth of the ratchet 95.

It will thus be understood that at one step a high portion of the disc 99 is opposed to the reversing switch generally indicated as 101, and at the next step a low portion of the notch 100 is opposed thereto. For example, in the position in which the parts are shown in Fig. 10, the reversing switch leaf 101 is seated in one of the notches 100 and is out of contact with the opposed switch member 102 and is in contact with a lower contact member 103. At the same time, its associated leaf 104 with the spacing block 105 of insulating material is out of contact with the opposed contact member 106 and is in contact with the opposite contact member 107. This relationship is reversed at each energization of the solenoid 91, that is to say, each time the operator is successful in hitting the photo cell 51 with a flash of light.

Referring to the wiring diagram, the commercial current source, which includes the lines X and Y, in this case alternating current, pro-

vides the energy for the photoelectric amplifier 6 and for the transformer 90. It also, by the lines 110, 111 provides energy for the motor 5 as by the conductive connections 112 and 113.

5 The lines 110, 111 also extend up to the reversing switch, to the leaves 101 and 104. 114 and 115 further connect the windings of the motor 5 with the leaves 103, 106 and 102, 107, respectively. Thus, the lines 114, 115 are reversed at each hit in relation to the main lines 110, 111 or X and Y, and the reversing motor changes its direction of movement at each hit.

10 Any suitable switch 120 may be employed, which serves to break the motor circuit. It will be understood that it may be opened and closed manually or, for slot machine operation, any suitable means may be employed for breaking the switch 120 after a predetermined number of shots.

20 Referring to the modified form of Figs. 13 and following, 125 illustrates a motor having a constant rotational direction. 126 is any suitable gear reduction, and 127 indicates a coupling effective to drive a driving shaft 128 mounted in the bearings 129 on any suitable base 130. The shaft 128 has an enlarged central portion 131 having two diametrically opposed slots 132, as shown for example in Fig. 20. Axially slideable in one of said slots is a retaining member or block 133. In the opposite slot is the slideable wedge member 134, having cam ends 135 opposed to locking balls 136, 137, which in turn are opposed to locking bands 138, 139. The locking bands 138 and 139 are split as illustrated in Fig. 20, and each has one of its free ends secured to the enlarged portion 131 of the shaft 128. The locking bands are positioned within suitable apertures in pinions 140, 141, respectively, and serve to engage the pinions frictionally, when expanded by means of the balls 136, 137 and cam ends 135 of the wedge member 134. It will be understood that these pinions are loose on the shaft 128 and that both pinions are in mesh with the bevel gear 142 on the vertical shaft 143, mounted in any suitable bearing 144 in the base 130.

45 Surrounding the shaft 128 and its enlarged portion 131 is a clutch ring 146. It will be observed, as in Fig. 17, that the members 133 and 134 each has outwardly extending prongs 133a and 134a, located at opposite sides of said ring 146. The rings is provided with a groove 147 engaged by or receiving the pins 148, mounted on a pivoted yoke 149, fixed on a shaft 150, mounted in any suitable bearing or bearings 151, 152, on the base 130. The opposite end of the shaft 150 carries a lever 153, the ends of which are received in slot 154 of plungers 155, 156, associated with electric magnetic coils 157, 158, which also may be mounted on the base 130 at any suitable point thereof. The vertical shaft 143 is connected by any suitable coupling to the shaft 18, controlling the pulley 20, that portion of the device being the same as shown in the form of Figs. 1 and following, it being understood that the rotation of the pulley 20 is effective to rotate the belt 21, which actuates the target mechanism elsewhere described.

70 In the operation of the above variation it will be understood that it is in contrast with the form shown in the earlier figures, in which a reversing motor 5 was employed, the rotational direction of the motor 5 being actually reversed in order to reverse the movement of the belt 21 and thus of the target. In the present device,

as shown in Figs. 13 and following, the motor itself, indicated at 125, has a uni-directional rotation. The motor, however, drives a clutch mechanism, which clutch mechanism is actuated to reverse the rotation of the pulley 20, and thus to reverse the direction of movement of the belt 21.

10 In contrasting, for example Fig. 21 with Fig. 12, the cam 99, with its notches 100 and its opposed leaf switch or contact 101, is opposed to but two switch contacts, namely 160 and 161. One of the switch contacts 160 is in circuit with the electric magnetic coil 157 and therefore is effective, when the circuit is closed, to energize the coil 157 and pull up its corresponding plunger 155, this being the position of the parts shown in Figs. 17, 18 and 21. This movement of the lever 153 is effective to rotate the shaft 150 to move the clutch wedge 134, and thus to de-clutch one of the pinions 136 or 137 and put 20 the other in clutch.

It will be understood, without going into the wiring diagram, that the wheel 99 of Fig. 21, as in Fig. 12, is rotated one step in response to every hit recorded against the photo cell 51. The result of a hit is the movement of the member 99 one step, and if the contact 101 is in a notch, the movement of the member 99 one step leaves the contact in engagement with one of the intermediate portions of maximum diameter. On the other hand, if the contact 101 is already in contact with one of the portions of maximum diameter, a hit will cause it to drop into one of the notches. It will be understood that the result of a hit, therefore, is always to energize one of the solenoids and to de-energize the other. Hence, each hit results in a movement of the clutch mechanism above described and the consequent reversal in the direction of rotation of the pulley 20 and thus the direction of movement of the belt 21.

45 This change in the directional movement of the belt 21 causes a reversal in the position of the target 54. We may employ the same reversal means, shown for example in Figs. 2 to 8. However, we illustrate in Figs. 14, 15 and 16 a variant reversing means, which is somewhat simpler. Referring, for example, to Figs. 14 to 16, we illustrate a carriage 200 having upper flanges 201 and lower flanges 202. On the lower flanges 202 are mounted the rollers 27, and on the upper flanges are mounted the rollers 30, which serve to center and guide the carriage just as in connection with the corresponding structure of Fig. 2. A similar electric contact 72 is also employed on the two carriages.

55 Mounted on the carriage 200 are an upper bearing 203 and a lower bearing 204. An inner stationary shaft 205, surrounded by an outer movable sleeve 206, extends downwardly through the bearing 203 and is secured to the lower bearing structure 204. The sleeve 206 is rotatable about the shaft 205 and is rotatable within both of the bearings. It carries an exterior reel 207, which in turn carries an arm 208 with flanges 209, adapted to abut against the carriage 200, and thus to limit the rotation of the reel of the sleeve 206 to approximately 180 degrees, as illustrated in Fig. 15. Surrounding and secured to the reel is a flexible cable 210, the opposite ends of which are secured to the belt 21, as at 211 and at 212. It will therefore be understood that, in response to a change in the direction of movement of the belt 21, the reel is rotated through 180 degrees of arc, and this causes a correspond- 75

ing rotation of the sleeve 206 and of the target structure carried thereby.

The dotted line position in Fig. 15 illustrates one limit of rotation of the reel and the lever, and the full line position illustrates the other. 214 are any suitable sleeves or guards for protecting the ends of the flexible member 210 where it may pass through or engage any portion of the carriage 200. It will be understood that the target structure 54 may be the same as shown in Fig. 2 or elsewhere.

It will be realized that whereas we have described and illustrated a practical and operative device, nevertheless many changes may be made in the size, shape, number and disposition of parts without departing from the spirit of our invention. We therefore wish our description and drawings to be taken as in a broad sense illustrative and diagrammatic, rather than as limiting us to our precise showing.

We claim:

1. In a target device, a target member and means for imparting movement thereto along a predetermined path, and means for reversing the movement of said target member along said path in response to a hit, said target member having a plurality of faces, and means for reversing said target member when the direction of movement of said target member is reversed, whereby at the time of a change of direction of movement of the target member a different face is presented to the observer.

2. In a target device, a reversible target member having a plurality of faces, means for imparting movement to said target member along a predetermined path, means for reversing the movement of the target member along said path when a hit is scored, and means for reversing said target member in response to the change in its direction of movement, whereby a different face is exposed to the marksman.

3. In a target device, a carriage and means for moving it along a predetermined path, a target member rotatably mounted upon said carriage, said target member having a pair of diametrically opposed faces, a photosensitive member mounted on and moving with said carriage and located within said target member, each face of said target member being apertured whereby, at each normal position of said target member, one of said apertures is aligned with said photosensitive member, and means for reversing said target member in response to a hit.

4. In a target device, a movable target including a carriage, guiding means therefor, and means for moving the carriage, including a belt, and means for actuating it, a target support rotatably mounted on said carriage for rotation about a generally vertical axis, a target element mounted on and rotatable with said support, and means for rotating said target element and support in response to a change in the direction of movement of the belt, including a flexible member secured at each end to the belt and having an intermediate portion surrounding and secured to the support, said support including a fixed portion mounted on said carriage, and a sleeve surrounding and rotatable about said fixed portion, a reel on said sleeve about which said flexible member is passed and to which it is secured, and means for limiting the rotation of said reel to a predetermined arc.

5. A target device including a guide, a carriage mounted for movement therealong, motor means adapted to reciprocate the carriage along

the guide, a target having a plurality of faces movably mounted on the carriage, means associated with the carriage and target for moving the target with respect to the carriage upon a change of direction of carriage movement to bring a new face of the target into the view of an observer, photo-sensitive means on the carriage and operatively associated with the several faces of the target, means for controlling the motor means to cause a reversal thereof and bring about a change in direction of travel of the carriage along the guide, an electric connection for the photo-sensitive means operative independent of the position of the target and carriage, and an electric amplifying device in circuit with the photo-sensitive means, and the motor control means, whereby the current controlled in the photo-sensitive means by a flash of light directed upon the face of the target exposed to the observer and impinging upon said means causes the operation of the motor control to reverse the motor.

6. In a target device, a carriage, and means for imparting movement thereto, a target member movably mounted upon said carriage and having a plurality of apertured faces, light sensitive means on the carriage so located that at a plurality of positions of the target member with respect to the carriage, an aperture is aligned with the light sensitive means, means for reversing the direction of movement of the carriage, and means for moving the target member in relation to the carriage.

7. In a target device, a carriage, and means for imparting movement thereto, a target member movably mounted upon said carriage and having a plurality of apertured faces, light sensitive means on the carriage so located that at a plurality of positions of the target member with respect to the carriage, an aperture is aligned with the light sensitive means, means for reversing the direction of movement of the carriage, and means for moving the target member in relation to the carriage when the direction of movement of the carriage is reversed.

8. In a target device, a carriage, and means for imparting movement thereto, a target member movably mounted upon said carriage and having a plurality of apertured faces, light sensitive means on the carriage so located that at a plurality of positions of the target member with respect to the carriage, an aperture is aligned with the light sensitive means, means for reversing the direction of movement of the carriage, when the light sensitive means is struck by a flash of light, and means for moving the target member in relation to the carriage.

9. In a target device, a carriage, and means for imparting movement thereto, a target member movably mounted upon said carriage and having a plurality of apertured faces, light sensitive means on the carriage so located that at a plurality of positions of the target member with respect to the carriage, an aperture is aligned with the light sensitive means, means for reversing the direction of movement of the carriage, when the light sensitive means is struck by a flash of light, and means for moving the target member in relation to the carriage when the direction of movement of the carriage is reversed.

10. In a target device, a target carriage and means for imparting movement thereto along a predetermined path, a target member, rotatably mounted upon the carriage, and having a pair of generally diametrically opposed faces, a photo-

sensitive member mounted on and moving with the carriage and located within the target member, each face of the target member being apertured, whereby at each firing position of said target member, one of the apertures is aligned with the photo-sensitive member, means for reversing the direction of movement of the carriage and means for rotating the target member through an angle of approximately 180 degrees.

11. In a target device, a target carriage and means for imparting movement thereto along a predetermined path, a target member rotatably mounted upon the carriage, and having a plurality of visible target faces arranged generally back to back, a photo-sensitive member mounted on and moving with the carriage and located within the target member, each face of the target member being apertured, whereby, at each firing position of the target member, one of said apertures is aligned with the photo-sensitive member, means for reversing the direction of movement of the carriage, and means for rotating the target member through an angle such that the face visible prior to reversal is hidden and a face invisible prior to reversal becomes visible.

12. In a target device, a target carriage and means for imparting movement thereto along a predetermined path, a target member rotatably mounted upon the carriage, and having a pair of generally diametrically opposed faces, means for rotating the target upon said carriage, a photo-sensitive member mounted on and moving with the carriage and located within the target member, each face of the target member being apertured, whereby, at each firing position of said target member, one of the apertures is aligned with the photo-sensitive member.

13. A target device including a housing having an opening on one side thereof, a track within the housing behind the opening, a flexible drive member generally parallel with and co-extensive with the track, a motor adapted to drive the flexible member, motor control means including means for reversing the direction of rotation of the motor, a carriage mounted for travel along the track, a driving connection between the carriage and the flexible member, a target on the carriage having a plurality of apertured faces, only one of which is at a time visible through the open side of the housing, light sensitive means on the carriage so positioned with respect to the target faces as to be exposed to view only through the aperture in the target face which is visible through the open wall of the housing, means associated with the target adapted upon each reversal in direction of movement of the carriage to bring a different target face into view through the open wall of the housing, and coin control means for conditioning the entire device for operation.

14. In a target device, a target carriage and means for moving it along a path, light sensitive means mounted on and moving with said carriage, a target figure movably mounted on said carriage, said figure having a plurality of target faces, each such face being apertured in line with said light sensitive means, and means for moving said figure in relation to said carriage and for exposing said plurality of faces individually to the user of the target device with said light sensitive means exposed to the user through an aperture of the particular target face exposed to the user.

15. A target device including a target body

mounted for movement, light sensitive means mounted within said target body, said body having a plurality of target faces, each such face being apertured in line with said light sensitive means, and means for moving said body for exposing said plurality of faces individually to the user of the target device, with said light sensitive means exposed to the user through an aperture of the particular target face exposed to the user.

16. A target device including a target body mounted for movement, light sensitive means mounted within said target body, said body having a plurality of target faces, each such face being apertured in line with said light sensitive means, means for moving said body for exposing said plurality of faces individually to the user of the target device, with said light sensitive means exposed to the user through an aperture of the particular target face exposed to the user, and means responsive to energization of said light sensitive means by a flash of light through the aperture of said particular face for actuating the target body moving means.

17. In a target device, a carriage, and means for imparting movement thereto, a target member movably mounted upon said carriage and having a plurality of apertured faces, light sensitive means on the carriage so located that at a plurality of positions of the target member with respect to the carriage an aperture is aligned with the light sensitive means, means for reversing the direction of movement of the carriage, and means for moving the target member in relation to the light sensitive means.

18. In a target device, a carriage, and means for imparting movement thereto, a target member movably mounted upon said carriage and having a plurality of apertured faces, light sensitive means on the carriage so located that at a plurality of positions of the target member with respect to the carriage an aperture is aligned with the light sensitive means, means for reversing the direction of movement of the carriage, and means for moving the target member from one of said positions to another of said positions.

19. In a target device, a carriage, and means for imparting movement thereto, a target member movably mounted upon said carriage and having a plurality of apertured faces, light sensitive means on the carriage so located that at a plurality of positions of the target member with respect to the carriage an aperture is aligned with the light sensitive means, means for reversing the direction of movement of the carriage, means for moving the target member from one of said positions to another of said positions, and means controlled by the marksman for actuating said reversing means and actuating said target moving means.

20. A target device including a target body mounted for movement, light sensitive means mounted within said target body, said body having a plurality of target faces, each such face being apertured in line with said light sensitive means, means for moving said body for exposing said plurality of faces individually to the user of the target device, with said light sensitive means exposed to the user through an aperture of the particular target face exposed to the user, and means controlled by the marksman for actuating said body moving means.

JAWN R. HALL.

WILLIAM P. FALKENBERG.