

Sept. 23, 1952

D. LEWIS

2,611,491

COLLAPSIBLE DISPLAY RACK FOR CIGAR BOXES AND SIMILAR ITEMS

Filed Aug. 11, 1950

3 Sheets-Sheet 1

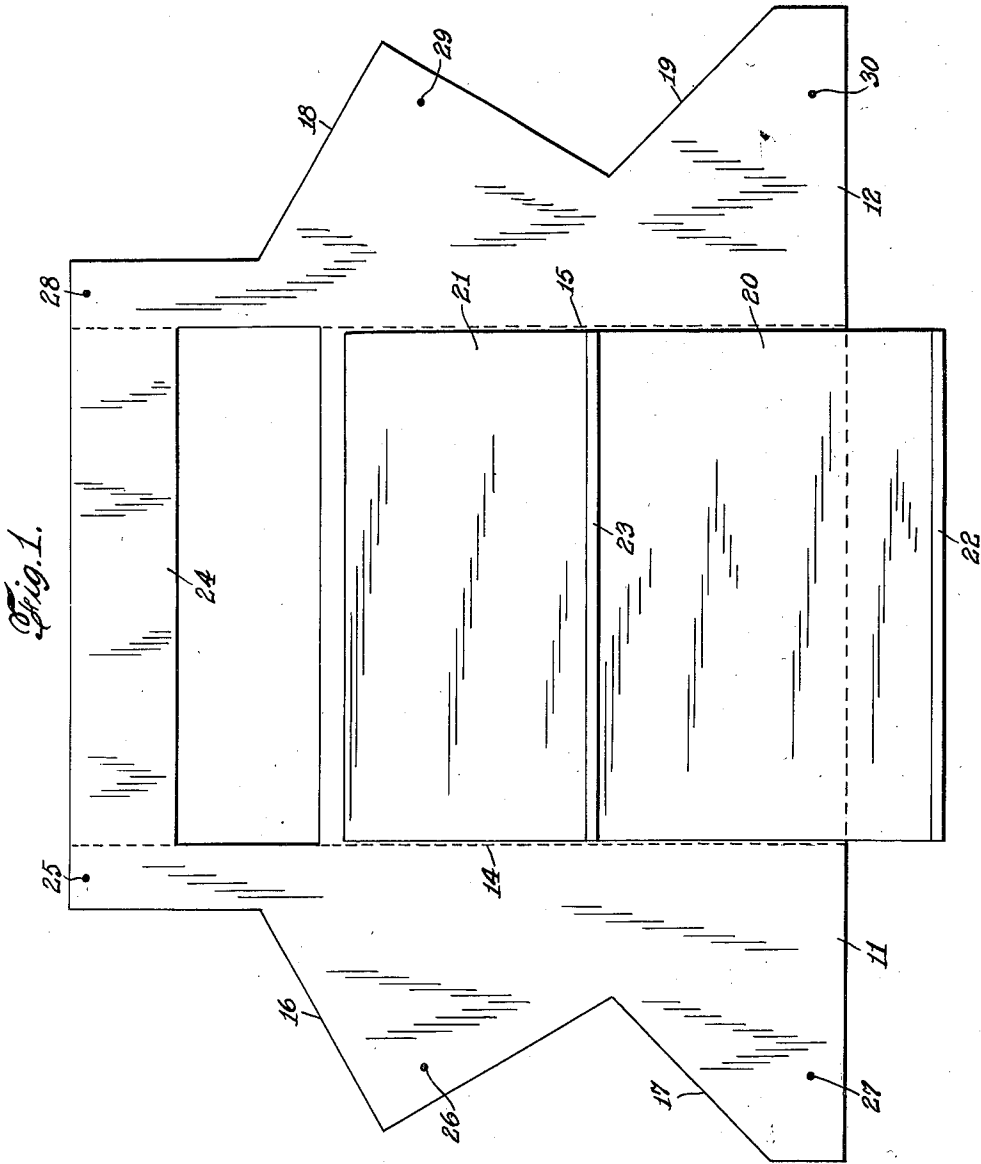

INVENTOR.  
DONALD LEWIS

BY *Arthur H. Moran*  
ATTORNEY.

Sept. 23, 1952

D. LEWIS

2,611,491

COLLAPSIBLE DISPLAY RACK FOR CIGAR BOXES AND SIMILAR ITEMS

Filed Aug. 11, 1950

3 Sheets-Sheet 2

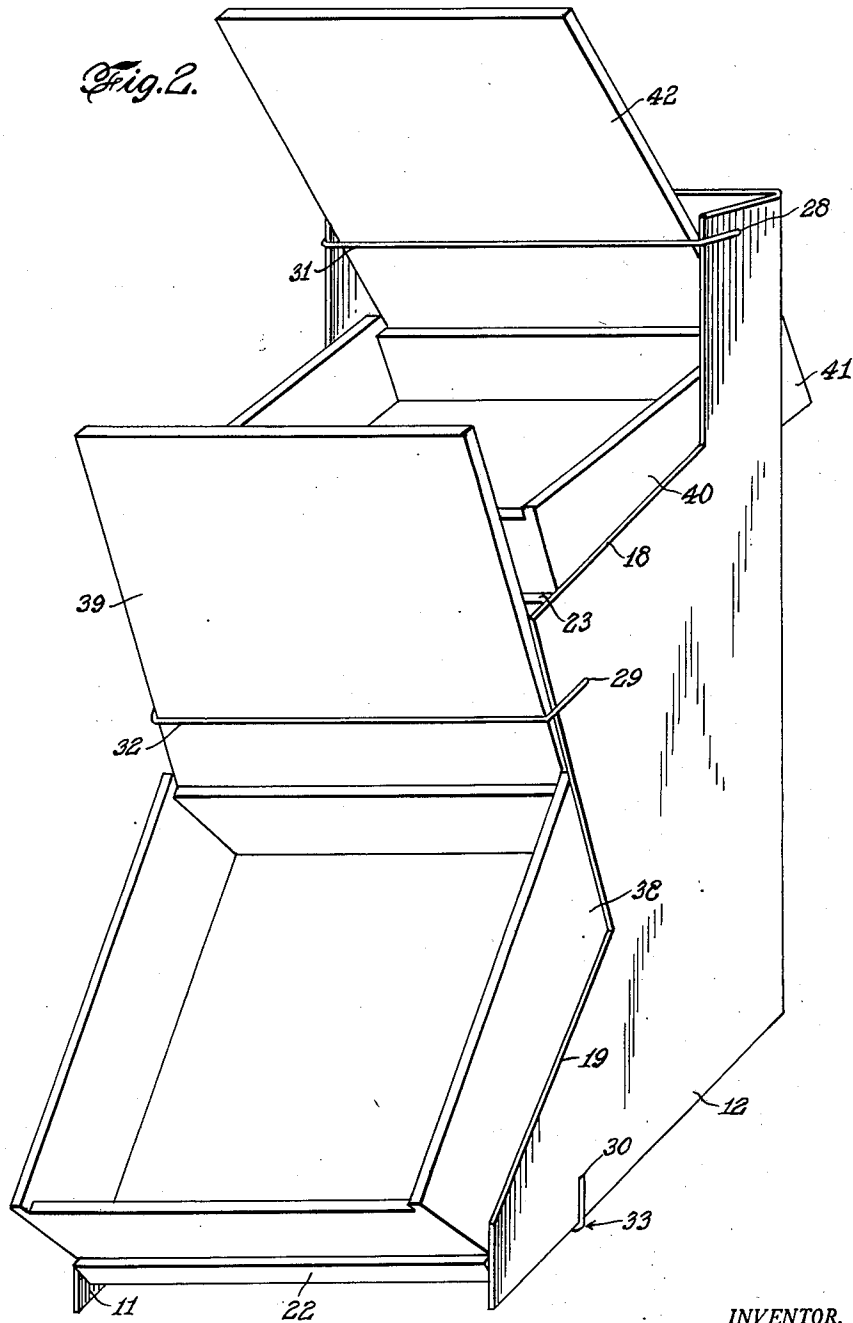

INVENTOR.  
DONALD LEWIS

BY *James W. Keaton*  
ATTORNEY.

Sept. 23, 1952

D. LEWIS

2,611,491

COLLAPSIBLE DISPLAY RACK FOR CIGAR BOXES AND SIMILAR ITEMS

Filed Aug. 11, 1950

3 Sheets-Sheet 3

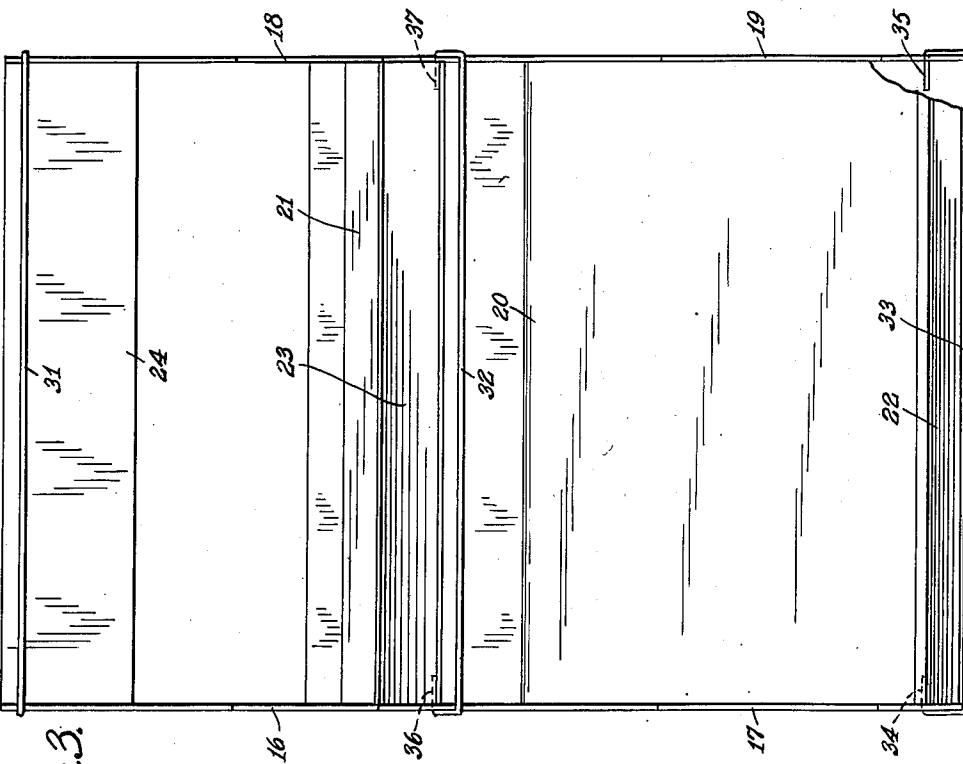
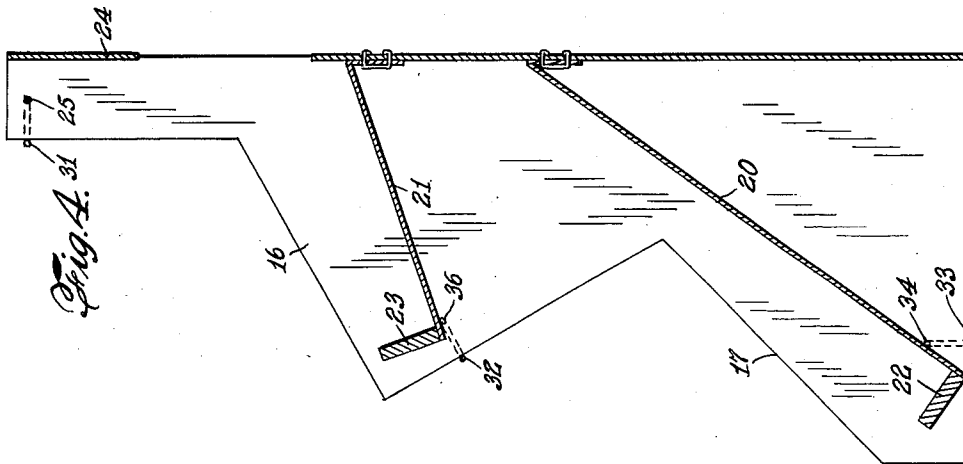

Fig. 3.

INVENTOR.  
DONALD LEWIS

BY *James H. Mason*  
ATTORNEY

# UNITED STATES PATENT OFFICE

2,611,491

## COLLAPSIBLE DISPLAY RACK FOR CIGAR BOXES AND SIMILAR ITEMS

Donald Lewis, Dallas, Tex., assignor to I. Lewis Cigar Manufacturing Company, Newark, N. J., a corporation of New Jersey

Application August 11, 1950, Serial No. 178,769

2 Claims. (Cl. 211-73)

1

2

This invention relates to a collapsible display rack and has as a particular object the provision of a stand adapted for the attractive display and exhibition of cigars and similar items of merchandise in the original containers while situated on counters, in store windows and in similar places where they are offered for sale.

Cigars are usually placed in open boxes with the lids elevated so as to show prominently the brand label on the inside of the cover as well as the cigars situated in the container. Customarily these tops are merely propped up or held in upright position in makeshift fashion by props, adhesive tape or similar means.

An object of the invention is to provide a display stand for holding a plurality of cigar boxes at an elevated position in tandem relationship to each other and with the lids positioned so as to afford unimpaired vision of the immediately adjacent box and to provide means for readily collapsing the entire assembly for shipping convenience.

In accordance with the invention, a display rack is provided comprising a blank cutout having a back portion and side wings hinged thereto and one or more trays hinged to the back which may be moved into an angular position when the stand is erected for supporting cigar boxes or the like, and cross members for positioning the side wings adjacent to the trays and for holding the trays at an angular position to display the contents of the boxes and whereby the box tops are elevated so that the brand names may be readily displayed to and viewed by prospective purchasers.

Referring to the drawings, Figure 1 shows the blank cutout for the display stand in flattened position for shipping purposes. Figure 2 is a perspective view of the display stand in assembled position and showing a plurality of cigar boxes disposed therein for dispensing and sale purposes. Figure 3 is a front elevation of my improved display stand showing in particular the arrangement of the cross members for supporting the trays and for holding the box lids in upright position. Figure 4 is a vertical section of my improved cigar box stand.

Referring to the drawings and in particular to Figure 1, it will be seen that a blank cutout is provided, suitably stamped from cardboard or other semi-rigid material, comprising a backing 10 and side wing members 11 and 12 connected with the back 10 along hinge lines 14 and 15. These side wings 11 and 12 are provided with angularly sloping stepped portions 16 and 17 on side wing 11 and 18 and 19 on side wing 12 for a purpose that

will later be apparent. Hingedly secured to the backing 10 of the blank cutout are trays 20 and 21 for supporting the cigar boxes when the device is in assembled position. The lower tray 20 is somewhat longer than the upper tray 21 for properly positioning the boxes relative to one another for display purposes and terminates in a flange 22. A similar flange 23 is provided at the extremity of the upper tray 21.

It will be observed that the upper portion of the backing 10 is formed with a rectangular cutout area 24 through which a portion of the container extends when mounted upon the tray 23. The side wing 11 has openings 25 at the upper extremity, 26 on the stepped portion 16, and 27 on the stepped portion 17, while side wing 12 has similar openings 28, 29 and 30 as will be readily apparent.

The blank cutout is very easily assembled in upright position for the supporting and displaying of cigar boxes, lipsticks, pencils and similar articles of merchandise and it will be seen that the wings 11 and 12 are merely moved forward at 90° to the backing 10 and the trays 20 and 21 moved into a sloping position whereupon cross members such as wires or struts 31, 32 and 33 are threaded into the respective pairs of openings, 25-26, 27-28 and 29-30. Although these cross members or struts may assume many forms, it will be observed that in the present embodiment for purposes of illustration I have shown these members to be of semi-flexible steel wire reversely bent at the extremities as shown at 34 and 35 in Figure 3 on the wire strut 33.

It will be apparent from the foregoing that the wire strut 33 positions the side wings 11 and 12 closely adjacent to the edges of the lower box supporting tray 20 and the reverse extensions 34 and 35 thereof provide support for lower tray 20 as shown particularly in Figure 4. The cross member 32 is likewise provided with reverse bends 36 and 37 which perform the function of properly locating the side wings 11 and 12 with respect to the sides of the upper tray 21 and at the same time provide supporting means through extensions 36 and 37 for the upper tray 21 as will be clearly apparent from Figure 4. The upper cross member or strut 31 of similar form serves to properly position the upper portions of the side wings 11 and 12 relative to each other.

When the display stand has been assembled in the foregoing manner and as shown particularly in Figure 4, a container for cigars or similar articles 38 may be positioned upon the lower tray 20 in the manner shown best in Figure 2 so that the lower edge of the box is supported by

the flange 22 on the tray 20 and the box top 39 is slipped in back of the cross member 32 and is thereby supported in upright position for the prominent display of the brand name on the inside of the box top. A second container 40 for cigars or other articles may be located directly above and adjacent to the box 38 in the manner illustrated in Figure 2 so that the lower front edge of the box engages the flange 23 on the upper tray 21 and the rear lower edge of the box 41 protrudes through the opening 24 formed in the backing 10. It will be observed that the top of the box 42 is maintained and held in an elevated position to prominently display the brand name on the interior thereof by virtue of the cross member 31.

A most important advantage of the present invention is that it effects valuable economy in the saving of counter space since two or more boxes may be situated in prominent display position on counter space usually occupied by a single box. This feature is rendered feasible through the low center of gravity of the display in its entirety resulting in the stand's possession of a very substantial degree of stability.

When the boxes are displayed on my improved rack in the foregoing manner it will be appreciated that the contents of both boxes as well as the trade names on the interior of the cover members are clearly visible and displayed in an attractive manner to shoppers viewing the displays through store windows or while the display stands are situated on cigar store counters or the like. Furthermore, it will be appreciated that while affording an attractive display means for the articles in question the stand may be conveniently shipped and stored in flattened blank position and may be easily assembled and the containers for cigars or similar articles conveniently positioned thereon for display purposes.

Other advantages of the invention will readily be apparent to those skilled in the art and various changes and modifications of the specific embodiments described herein may be made without departing from the spirit and scope of the invention as defined by the appended claims.

I claim:

1. A rack for the display of cigar boxes and similar containers comprising a collapsible cut out of cardboard or other suitable material hav-

ing a back portion and hinged side wing portions at either side of the back portion, a plurality of trays for supporting cigar boxes in display fashion transversely hinged to the back portion of the cut out and located one above the other in spaced relation, the side wings being cut away to afford a clear view of the container contents, cross members connected at the outer extremities of the wings for holding the wings closely adjacent to the sides of the trays, means attached to the side wings for supporting the trays at an angular position when said wings are held closely adjacent thereto by said cross members, the cross members being located above the hinge point of each box supporting tray thereby providing a support for holding the box top in an elevated position to display cigars or other articles contained within the box.

2. A rack for the display of cigar boxes and similar containers comprising a collapsible cardboard cut out having a back portion and side wings hinged to thereto, a plurality of trays hinged transversely relative to the back portion and disposed one above another in spaced relation, means attached to the side wings for supporting the trays in sloping fashion when said wings are closely positioned to the sides of the trays, the side wings of the device being cut away at an angle approximating the slope at which the trays and boxes supported thereon are disposed at, cross members connecting the outer extremities of the wings together and in close proximity to the sides of the box supporting trays, said cross members being disposed above the hinge point of each of the trays for holding the box top in display position whereby the brand name and container contents of the boxes displayed on said rack are prominently visible.

DONALD LEWIS.

REFERENCES CITED

The following references are of record in the file of this patent:

UNITED STATES PATENTS

Number	Name	Date
1,189,371	Lyons	July 4, 1916
1,662,637	Chase	Mar. 13, 1928
1,827,803	Silberstein	Aug. 14, 1930
2,298,427	Slanhoff	Oct. 13, 1942