



US007845499B2

(12) **United States Patent**  
**Higgins et al.**

(10) **Patent No.:** **US 7,845,499 B2**

(45) **Date of Patent:** **Dec. 7, 2010**

(54) **APPARATUS AND METHOD FOR SEPARATING AND CONCENTRATING FLUIDS CONTAINING MULTIPLE COMPONENTS**

(75) Inventors: **Joel C. Higgins**, Claypool, IN (US);  
**Matthew Swift**, Fort Wayne, IN (US);  
**Nathan Gordon**, Plymouth, IN (US);  
**Barry F. Hecker**, Pierceton, IN (US)

(73) Assignee: **Biomet Biologics, LLC**, Warsaw, IN (US)

(\* ) Notice: Subject to any disclaimer, the term of this patent is extended or adjusted under 35 U.S.C. 154(b) by 1231 days.

(21) Appl. No.: **11/441,276**

(22) Filed: **May 25, 2006**

(65) **Prior Publication Data**

US 2006/0273050 A1 Dec. 7, 2006

**Related U.S. Application Data**

(63) Continuation-in-part of application No. 10/932,882, filed on Sep. 2, 2004, now Pat. No. 7,374,678, which is a continuation-in-part of application No. 10/445,381, filed on May 23, 2003, now Pat. No. 7,179,391.

(60) Provisional application No. 60/383,013, filed on May 24, 2002.

(51) **Int. Cl.**  
**B01D 21/26** (2006.01)

(52) **U.S. Cl.** ..... **210/380.1**; 210/782; 210/789; 210/360.1; 210/516; 422/72; 422/101; 494/43; 494/50; 494/67; 604/6.01; 604/6.05; 604/6.15; 604/218; 604/403

(58) **Field of Classification Search** ..... 210/782, 210/789, 787, 360.1, 380.1, 513-516, 518, 210/121, 122; 422/72, 101; 494/43, 50, 494/67, 16; 604/6.01, 6.05, 6.15, 218, 403  
See application file for complete search history.

(56) **References Cited**

U.S. PATENT DOCUMENTS

280,820 A 7/1883 Hickson

(Continued)

FOREIGN PATENT DOCUMENTS

AU 696278 1/1999

(Continued)

OTHER PUBLICATIONS

Clotalyt™ Automatic Clotting Factor, Would you like to have an autologous thrombin for rapid clotting and haemostasis?, brochure, Biomet Biologics, Inc., Feb. 2007 (12 pages).

(Continued)

*Primary Examiner*—Tony G Soohoo  
*Assistant Examiner*—David C Mellon

(74) *Attorney, Agent, or Firm*—Harness, Dickey

(57) **ABSTRACT**

An apparatus that allows for separating and collecting a fraction of a sample. The apparatus, when used with a centrifuge, allows for the creation of at various fractions in the apparatus. A buoy system that may include a first buoy portion and a second buoy member operably interconnected may be used to form at least three fractions from a sample during a substantially single centrifugation process. Therefore, the separation of various fractions may be substantially quick and efficient. Also selected fractions from the sample can be applied to a patient, either alone or as part of a mixture.

**29 Claims, 16 Drawing Sheets**

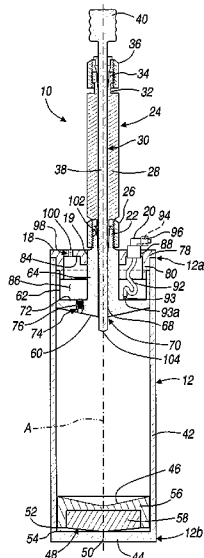

U.S. PATENT DOCUMENTS							
593,333	A	11/1897	Park	4,632,761	A	12/1986	Bowers et al.
1,468,313	A	9/1923	Lux	4,639,316	A	1/1987	Eldegheidy
1,593,814	A	7/1926	Vogel	4,650,678	A	3/1987	Fuhge et al.
2,553,004	A	5/1951	Rabatine	4,655,211	A	4/1987	Sakamoto et al.
3,409,165	A	11/1968	Creith	4,672,969	A	6/1987	Dew
3,441,143	A	4/1969	Kudlaty	4,675,117	A	6/1987	Neumann et al.
3,453,364	A	7/1969	Flodin et al.	4,680,025	A	7/1987	Kruger et al.
3,469,369	A	9/1969	Helmke	4,714,457	A	12/1987	Alterbaum
3,508,653	A	4/1970	Coleman	4,735,616	A	4/1988	Eibl et al.
3,545,671	A	12/1970	Ross	4,735,726	A	4/1988	Duggins
3,723,244	A	3/1973	Breillatt, Jr.	4,755,300	A	7/1988	Fischel et al.
3,779,383	A	12/1973	Ayres	4,755,301	A	7/1988	Bowers
3,785,549	A	1/1974	Latham, Jr.	4,770,779	A	9/1988	Ichikawa et al.
3,814,248	A	6/1974	Lawhead	4,776,964	A	10/1988	Schoendorfer et al.
3,850,369	A	11/1974	Bull et al.	4,818,291	A	4/1989	Iwatsuki et al.
3,879,295	A	4/1975	Glover et al.	4,818,386	A	4/1989	Burns
3,894,952	A	7/1975	Ayres	4,828,710	A	5/1989	Itoh et al.
3,896,733	A	7/1975	Rosenberg	4,832,851	A	5/1989	Bowers et al.
3,897,343	A	7/1975	Ayres	4,844,818	A	7/1989	Smith
3,909,419	A	9/1975	Ayres	4,846,835	A	7/1989	Grande
3,929,646	A	12/1975	Adler	4,850,952	A	7/1989	Figdor et al.
3,931,010	A	1/1976	Ayres et al.	4,853,137	A	8/1989	Ersson et al.
3,931,018	A	1/1976	North, Jr.	4,871,462	A	10/1989	Fischel et al.
3,935,113	A	1/1976	Ayres	4,874,368	A	10/1989	Miller et al.
3,941,699	A	3/1976	Ayres	4,877,520	A	10/1989	Burns
3,951,801	A	4/1976	Ayres	4,879,031	A	11/1989	Panzani et al.
3,957,654	A	5/1976	Ayres	4,902,281	A	2/1990	Avoy
3,972,812	A	8/1976	Gresl, Jr.	4,909,251	A	3/1990	Seelich et al.
3,982,691	A	9/1976	Schultz	4,917,801	A	4/1990	Luderer et al.
4,001,122	A	1/1977	Griffin	4,928,603	A	5/1990	Rose et al.
4,046,699	A	9/1977	Zine, Jr.	4,929,242	A	5/1990	Desecki et al.
4,055,501	A	10/1977	Cornell	4,939,081	A	7/1990	Figdor et al.
4,059,108	A	11/1977	Latham, Jr.	4,943,273	A	7/1990	Pages et al.
4,077,396	A	3/1978	Wardlaw et al.	4,946,601	A	8/1990	Fiehler
4,088,582	A	5/1978	Murty et al.	4,957,637	A	9/1990	Cornell
4,146,172	A	3/1979	Cullis et al.	4,957,638	A	9/1990	Smith
4,152,270	A	5/1979	Cornell	4,983,157	A	1/1991	Pober et al.
4,154,690	A	5/1979	Ballies et al.	4,983,158	A	1/1991	Headley
4,159,896	A	7/1979	Levine et al.	4,985,153	A	1/1991	Kuroda et al.
4,187,979	A	2/1980	Cullis et al.	5,000,970	A	3/1991	Shanbhag et al.
4,204,537	A	5/1980	Latham, Jr.	5,002,571	A	3/1991	O'Donnell, Jr. et al.
4,225,580	A	9/1980	Rothman et al.	5,019,243	A	5/1991	McEwen et al.
4,269,718	A	5/1981	Persidsky	5,024,613	A	6/1991	Vasconcellos et al.
4,294,707	A	10/1981	Ikeda et al.	5,030,215	A	7/1991	Morse et al.
4,298,598	A	11/1981	Schwarz et al.	5,030,341	A	7/1991	McEwen et al.
4,300,717	A	11/1981	Latham, Jr.	5,045,048	A	9/1991	Kaleskas et al.
4,303,193	A	12/1981	Latham, Jr.	5,047,004	A	9/1991	Wells
4,314,823	A	2/1982	Rich, Jr. et al.	5,053,127	A	10/1991	Schoendorfer et al.
4,322,298	A	3/1982	Persidsky	5,053,134	A	10/1991	Luderer et al.
4,362,567	A	12/1982	Schwarz et al.	5,071,570	A	12/1991	Shiraki et al.
4,364,832	A	12/1982	Ballies et al.	5,080,262	A	1/1992	Herold et al.
4,377,572	A	3/1983	Schwarz et al.	5,086,784	A	2/1992	Levine et al.
4,379,849	A	4/1983	Heimreid	5,100,564	A	3/1992	Pall et al.
4,414,976	A	11/1983	Schwarz et al.	5,104,375	A	4/1992	Wolf et al.
4,416,654	A	11/1983	Schoendorfer et al.	5,112,484	A	5/1992	Zuk, Jr.
4,417,981	A	11/1983	Nugent	5,112,490	A	5/1992	Turpen
4,424,132	A	1/1984	Iriguchi et al.	5,131,907	A	7/1992	Williams et al.
4,427,650	A	1/1984	Stroetmann et al.	5,137,832	A	8/1992	Levine et al.
4,427,651	A	1/1984	Stroetmann et al.	5,141,645	A	8/1992	Shiraki et al.
4,442,655	A	4/1984	Stroetmann et al.	5,147,290	A	9/1992	Jonsson
4,443,345	A	4/1984	Wells	5,152,905	A	10/1992	Pall et al.
4,446,021	A	5/1984	Aufderhaar et al.	5,156,613	A	10/1992	Sawyer
4,453,939	A	6/1984	Zimmerman et al.	5,165,938	A	11/1992	Knighton
4,464,167	A	8/1984	Schoendorfer et al.	5,171,456	A	12/1992	Hwang et al.
4,511,662	A	4/1985	Baran et al.	5,173,295	A	12/1992	Wehling et al.
4,537,767	A	8/1985	Rothman et al.	5,178,602	A	1/1993	Wells
RE32,089	E	3/1986	Blatt et al.	5,185,001	A	2/1993	Galanakis
4,610,656	A	9/1986	Mortensen	5,190,057	A	3/1993	Sarfarazi
4,617,009	A	10/1986	Ohlin et al.	5,190,759	A	3/1993	Lindblad et al.
4,627,879	A	12/1986	Rose et al.	5,197,985	A	3/1993	Caplan et al.
4,631,055	A	12/1986	Redl et al.	5,203,825	A	4/1993	Haynes et al.
				5,204,537	A	4/1993	Bennet et al.
				5,206,023	A	4/1993	Hunziker et al.

5,207,638 A	5/1993	Choksi et al.	5,733,466 A	3/1998	Benebo et al.
5,217,426 A	6/1993	Bacehowski et al.	5,733,545 A	3/1998	Hood, III
5,217,627 A	6/1993	Pall et al.	5,736,033 A	4/1998	Coleman et al.
5,219,328 A	6/1993	Morse et al.	5,738,796 A	4/1998	Bormann et al.
5,226,877 A	7/1993	Epstein	5,750,025 A	5/1998	Holmes et al.
5,226,914 A	7/1993	Caplan et al.	5,785,700 A	7/1998	Olson
5,234,608 A	8/1993	Duff	5,786,217 A	7/1998	Tube et al.
5,236,604 A	8/1993	Fiehler	5,788,662 A	8/1998	Antanavich et al.
5,258,126 A	11/1993	Pall et al.	5,795,489 A	8/1998	Holm et al.
5,260,420 A	11/1993	Burnouf-Radosevich et al.	5,795,571 A	8/1998	Cederholm-Williams et al.
5,269,927 A	12/1993	Fiehler	5,795,751 A	8/1998	Apel
5,271,852 A	12/1993	Luoma, II	5,811,094 A	9/1998	Caplan et al.
5,279,825 A	1/1994	Wehling et al.	5,811,151 A	9/1998	Hendriks et al.
5,281,342 A	1/1994	Biesel et al.	5,817,519 A	10/1998	Zelmanovic et al.
5,290,552 A	3/1994	Sierra et al.	5,823,986 A	10/1998	Peterson
5,290,918 A	3/1994	Bui-Khac et al.	5,824,084 A	10/1998	Muschler
5,298,171 A	3/1994	Biesel et al.	5,830,359 A	11/1998	Knight et al.
5,304,372 A	4/1994	Michalski et al.	5,833,866 A	11/1998	Brown
5,316,674 A	5/1994	Pall et al.	5,834,418 A	11/1998	Brazeau et al.
5,318,524 A	6/1994	Morse et al.	5,837,150 A	11/1998	Langley et al.
5,318,782 A	6/1994	Weis-Fogh	5,840,502 A	11/1998	Van Vlasselaer
5,321,126 A	6/1994	van Dommelen et al.	5,860,937 A	1/1999	Cohen
5,322,620 A	6/1994	Brown et al.	5,863,892 A	1/1999	Stern et al.
5,330,974 A	7/1994	Pines et al.	5,865,785 A	2/1999	Bischof
5,344,752 A	9/1994	Murphy	5,889,584 A	3/1999	Wardlaw
5,370,802 A	12/1994	Brown	5,895,346 A	4/1999	Wells et al.
5,376,263 A	12/1994	Fischel	5,899,874 A	5/1999	Jonsson et al.
5,387,187 A	2/1995	Fell et al.	5,900,245 A	5/1999	Sawhney et al.
5,393,674 A	2/1995	Levine	5,906,934 A	5/1999	Grande et al.
5,395,923 A	3/1995	Bui-Khac et al.	5,916,557 A	6/1999	Berlowitz-Tarrant et al.
5,403,272 A	4/1995	Deniega et al.	5,916,743 A	6/1999	Lake et al.
5,405,607 A	4/1995	Epstein	5,918,622 A	7/1999	Perez et al.
5,411,885 A	5/1995	Marx	5,924,972 A	7/1999	Turvaville et al.
5,417,650 A	5/1995	Gordon	5,934,803 A	8/1999	Hutter
5,420,250 A	5/1995	Lontz	5,938,621 A	8/1999	Kelly et al.
5,443,481 A	8/1995	Lee	5,955,032 A	9/1999	Kelly et al.
5,454,958 A	10/1995	Fiehler	5,955,436 A	9/1999	Kunkle, Jr.
5,456,693 A	10/1995	Conston et al.	5,958,250 A	9/1999	Brown et al.
5,456,885 A	10/1995	Coleman et al.	5,958,253 A	9/1999	Holm
5,474,687 A	12/1995	Van Vlasselaer	5,980,734 A	11/1999	Itoh et al.
5,486,359 A	1/1996	Caplan et al.	6,010,627 A	1/2000	Hood, III
5,494,578 A	2/1996	Brown et al.	6,022,306 A	2/2000	Dumont et al.
5,494,592 A	2/1996	Latham, Jr. et al.	6,025,201 A	2/2000	Zelmanovic et al.
5,501,371 A	3/1996	Schwartz-Feldman	6,027,655 A	2/2000	Holm
5,505,685 A	4/1996	Antwiler	6,051,146 A	4/2000	Green et al.
5,510,102 A	4/1996	Cochrum	6,051,147 A	4/2000	Bischof
5,533,518 A	7/1996	Vogler	6,053,856 A	4/2000	Hlavinka
5,560,830 A	10/1996	Coleman et al.	6,054,122 A	4/2000	MacPhee et al.
5,575,778 A	11/1996	Hardt et al.	6,063,297 A	5/2000	Antanavich et al.
5,577,513 A	11/1996	Van Vlasselaer	6,063,624 A	5/2000	Kandler et al.
5,585,007 A	12/1996	Antanavich et al.	6,071,421 A	6/2000	Brown
5,588,958 A	12/1996	Cunningham et al.	6,071,422 A	6/2000	Hlavinka et al.
5,589,462 A	12/1996	Patat et al.	6,071,423 A	6/2000	Brown et al.
5,601,727 A	2/1997	Bormann et al.	6,090,793 A	7/2000	Zimmermann et al.
5,607,579 A	3/1997	Latham, Jr. et al.	6,096,309 A	8/2000	Prior et al.
5,614,106 A	3/1997	Payrat et al.	6,117,425 A	9/2000	MacPhee et al.
5,618,663 A	4/1997	Delmas et al.	6,123,655 A	9/2000	Fell
5,632,895 A	5/1997	Tsukagoshi et al.	6,150,163 A	11/2000	McPherson et al.
5,632,905 A	5/1997	Haynes	6,153,113 A	11/2000	Goodrich et al.
5,641,414 A	6/1997	Brown	6,183,737 B1	2/2001	Zaleske et al.
5,641,622 A	6/1997	Lake et al.	6,196,987 B1	3/2001	Holmes et al.
5,643,192 A	7/1997	Hirsh et al.	6,197,325 B1	3/2001	MacPhee et al.
5,645,540 A	7/1997	Henniges et al.	6,200,287 B1	3/2001	Keller et al.
5,646,004 A	7/1997	Van Vlasselaer	6,200,606 B1	3/2001	Peterson et al.
5,648,223 A	7/1997	Van Vlasselaer	6,214,338 B1	4/2001	Antanavich et al.
5,649,903 A	7/1997	Deniega et al.	6,221,315 B1	4/2001	Giesler et al.
5,663,051 A	9/1997	Vlasselaer	6,245,900 B1	6/2001	Yamasaki et al.
5,674,173 A	10/1997	Hlavinka et al.	6,264,890 B1	7/2001	Bochringer et al.
5,707,331 A	1/1998	Wells et al.	6,274,090 B1	8/2001	Coelho et al.
5,707,647 A	1/1998	Dunn et al.	6,277,961 B1	8/2001	Hock et al.
5,707,876 A	1/1998	Levine	6,280,400 B1	8/2001	Niermann
5,716,616 A	2/1998	Prockop et al.	6,296,602 B1	10/2001	Headley
5,723,331 A	3/1998	Tube et al.	6,316,247 B1	11/2001	Katz et al.

6,322,785 B1 11/2001 Landesberg et al.  
 6,327,491 B1 12/2001 Franklin et al.  
 6,328,765 B1 12/2001 Hardwick et al.  
 6,342,157 B1 1/2002 Hood, III  
 6,351,659 B1 2/2002 Vilsmeier  
 6,368,298 B1 4/2002 Beretta et al.  
 6,398,972 B1 6/2002 Blasetti et al.  
 6,406,671 B1 6/2002 DiCesare et al.  
 6,410,334 B1 6/2002 Schmolz  
 6,417,004 B1 7/2002 Brady et al.  
 6,440,444 B2 8/2002 Boyce et al.  
 6,444,228 B1 9/2002 Baugh et al.  
 6,472,162 B1 10/2002 Coelho et al.  
 6,508,778 B1 1/2003 Verkaart et al.  
 6,516,953 B1 2/2003 DiCesare et al.  
 6,544,162 B1 4/2003 Van Wie et al.  
 6,558,341 B1 5/2003 Swisher  
 6,596,180 B2 7/2003 Baugh et al.  
 6,629,919 B2 10/2003 Egozy et al.  
 6,676,629 B2 1/2004 Andrew et al.  
 6,719,901 B2 4/2004 Dolecek et al.  
 6,733,471 B1 5/2004 Ericson et al.  
 6,758,978 B1 7/2004 Bedell  
 6,777,231 B1 8/2004 Katz et al.  
 6,803,022 B2 10/2004 DiCesare et al.  
 6,811,777 B2 11/2004 Mishra  
 6,835,377 B2 12/2004 Goldberg et al.  
 RE38,730 E 4/2005 Wells et al.  
 6,899,813 B2 5/2005 Dolecek et al.  
 6,905,612 B2 6/2005 Dorian et al.  
 6,911,202 B2 6/2005 Amir et al.  
 RE38,757 E 7/2005 Wells et al.  
 7,011,644 B1 3/2006 Andrew et al.  
 7,077,273 B2 7/2006 Ellsworth et al.  
 7,179,391 B2 2/2007 Leach et al.  
 7,223,346 B2 5/2007 Dorian et al.  
 7,470,371 B2\* 12/2008 Dorian et al. .... 210/787  
 2001/0009757 A1 7/2001 Bischof et al.  
 2002/0076400 A1 6/2002 Katz et al.  
 2002/0082220 A1 6/2002 Hoemann et al.  
 2002/0090711 A1 7/2002 Karlsson  
 2002/0104808 A1 8/2002 Blasetti et al.  
 2002/0114775 A1 8/2002 Pathak  
 2002/0161449 A1 10/2002 Muschler  
 2002/0169408 A1 11/2002 Beretta et al.  
 2002/0172666 A1 11/2002 Sacchi et al.  
 2002/0182664 A1 12/2002 Dolecek et al.  
 2003/0033021 A1 2/2003 Plouhar et al.  
 2003/0033022 A1 2/2003 Plouhar et al.  
 2003/0050709 A1 3/2003 Noth et al.  
 2003/0050710 A1 3/2003 Petersen et al.  
 2003/0082152 A1 5/2003 Hedrick et al.  
 2003/0185803 A1 10/2003 Kadiyala et al.  
 2003/0191429 A1 10/2003 Andrew et al.  
 2004/0120942 A1 6/2004 McGinnis et al.  
 2004/0171146 A1 9/2004 Katz et al.  
 2004/0182395 A1 9/2004 Brookman  
 2004/0182788 A1 9/2004 Dorian et al.  
 2004/0182795 A1 9/2004 Dorian et al.  
 2005/0076396 A1 4/2005 Katz et al.  
 2005/0084961 A1 4/2005 Hedrick et al.  
 2005/0109716 A1 5/2005 Leach et al.  
 2005/0130301 A1 6/2005 McKay et al.  
 2005/0153441 A1 7/2005 Hedrick et al.  
 2005/0153442 A1 7/2005 Katz et al.  
 2005/0196874 A1 9/2005 Dorian et al.  
 2005/0260174 A1 11/2005 Fraser et al.  
 2005/0260175 A1 11/2005 Hedrick et al.  
 2005/0282275 A1 12/2005 Katz et al.  
 2006/0083720 A1 4/2006 Fraser et al.  
 2006/0196885 A1 9/2006 Leach et al.  
 2006/0273049 A1 12/2006 Leach et al.  
 2006/0278588 A1 12/2006 Woodell-May

2007/0034579 A1 2/2007 Dorian et al.  
 2007/0036768 A1 2/2007 Fraser et al.  
 2007/0075016 A1 4/2007 Leach  
 2008/0217264 A1 9/2008 Leach et al.  
 2008/0217265 A1 9/2008 Leach et al.  
 2008/0283474 A1 11/2008 Leach et al.  
 2009/0014391 A1 1/2009 Leach et al.  
 2009/0101599 A1 4/2009 Dorian et al.  
 2009/0221075 A1 9/2009 Dorian et al.

FOREIGN PATENT DOCUMENTS

BR	9103724	3/1993
CA	1321138	8/1993
CA	2182862	6/1996
CN	1074709	7/1993
DE	56103	10/1860
DE	1443359	11/1968
DE	4202667	5/1993
EP	090997	10/1983
EP	0102773	3/1984
EP	0109374	5/1984
EP	0 142 339	11/1984
EP	0244834	11/1987
EP	0253198	1/1988
EP	0295771	12/1988
EP	0 417 818	9/1990
EP	0534178	3/1993
EP	534178	3/1993
EP	0592242	4/1994
EP	1 005 910	6/2000
EP	1006360	6/2000
EP	1289618	3/2003
EP	1427279 A1	6/2004
EP	1467746 A2	10/2004
EP	1509326	3/2005
EP	1670315 A2	6/2006
EP	1716901	11/2006
GB	854715	11/1960
JP	60-053845	3/1985
JP	60250014	12/1985
JP	2036872	2/1990
JP	02071747	3/1990
JP	02129224	10/2000
WO	WO-8400905	3/1984
WO	WO-8802259	4/1988
WO	WO-9010031	9/1990
WO	WO-9222312	12/1992
WO	WO-9305067	3/1993
WO	WO-9308904	5/1993
WO	WO-9407548	4/1994
WO	WO-9617871	6/1996
WO	WO00/61256	10/2000
WO	WO01/03756	1/2001
WO	WO01/83068	11/2001
WO	WO-0238610	5/2002
WO	WO-02060925	8/2002
WO	WO-03024215 A1	3/2003
WO	WO03/088905	4/2003
WO	WO 03/015800	6/2003
WO	WO-03053362 A2	7/2003
WO	WO-03092894	11/2003
WO	WO-03099412	12/2003
WO	WO-2004009207	1/2004
WO	WO-2004104553	12/2004
WO	WO-2005034843 A2	4/2005
WO	WO-2007142908 A1	12/2007

OTHER PUBLICATIONS

FibroStik™ Plasma Concentrator, Attention Operating Surgeon, Cell Factor Technologies, Inc., Jul. 2003.  
 GPS® III System, GPS® III Platelet Separation System, Leadership through Technology, brochure, Jul. 2007 (8 sheets).

- GPS® System, "Shoulder Recovery with the GPS® Platelet Concentrate System, Rotator Cuff Surgical Techniques," brochure, Cell Factor Technologies, Inc., Biomet Orthopaedics, Inc., (2004) 6 pages.
- International Search Report and Written Opinion mailed Jul. 2, 2008 for International Application No. PCT/US2008/004687 which claims priority to U.S. Appl. No. 60/911,407, filed Apr. 12, 2007.
- International Search Report for International Application No. PCT/US/0316506 mailed Oct. 13, 2003 which claims benefit of U.S. Appl. No. 60/383,013, filed May 24, 2002.
- International Search Report for International Application No. PCT/US2007/012587 mailed Nov. 6, 2007 which claims benefit of U.S. Appl. No. 11/441,276, filed May 25, 2006.
- Written Opinion of the International Preliminary Examining Authority mailed Mar. 17, 2009 for International Application No. PCT/US2008/004687 which claims priority to U.S. Appl. No. 60/911,407, filed Apr. 12, 2007.
- Anesthesiology, vol. 81, No. 4, pp. 1074-1077, Oct. 1994, Hiromasa Mitsuhashi, M.D., et al., "An Anaphylactic Reaction to Topical Fibrin Glue".
- Ann Thorac Surg, vol. 53, pp. 530-531, 1992, Mehmet C. Oz, M.D., et al., "Autologous Fibrin Glue From Intraoperatively Collected Platelet-Rich Plasma".
- Ann Thorac Surg, vol. 56, pp. 387-389, 1993, Robert L. Quigley, M.D., et al., "Intraoperative Procurement of Autologous Fibrin Glue".
- Bang, N.U., et al., "Plasma Protein Requirements for Human Platelet Aggregation" Ann. N.Y. Acad. Sci., 201:280-299 (1972).
- Berguer, R., R. L. Staerckel, E. E. Moore, F. A. Moore, W. B. Galoway, and M. B. Mockus. "Warning: fatal reaction to the use of fibrin glue in deep hepatic wounds. Case reports." *J Trauma* 31 (3 1991): 408-11.
- Berruyer, M., J. Amiral, P. Ffrench, J. Belleville, O. Bastien, J. Clerc, A. Kassir, S. Estanove, and M. Dechavanne. "Immunization by bovine thrombin used with fibrin glue during cardiovascular operations. Development of thrombin and factor V inhibitors," *J Thorac Cardiovasc Surg* 105 (5 1993): 892-7.
- Biopolymers, vol. 27, pp. 763-774, 1988, Gerald Marx, "Mechanism of Fibrin Coagulation Based on Selective, Cation-Driven, Protofibril Association".
- Brodke, et al., "Bone Grafts Prepared with Selective Cell Retention Technology Heal Canine Segmental Defects as Effectively as Autograft", SCR-Enriched Bone Crafts Heal Canine Segmental Defects, Journal of Orthopaedic Research (May 2006) pp. 857-866.
- Casali, B., F. Rodeghiero, a. Toso, B. Palmieri, R. Immovilli, C. Ghedini, and P. Rivasi. "Fibrin glue from single-donation autologous plasmapheresis." *Transfusion* 32 (7 1992): 641-3.
- Dallari, et al., "In Vivo Study on the Healing of Bone Defects Treated with Bone Marrow Stromal Cells, Platelet-Rich Plasma, and Freeze-Dried Bone Allografts, Alone and in Combination." Healing of Bone Defects, Journal of Orthopaedic Research (May 2006) pp. 877-888.
- DelRossi, A. J., A. C. Cernaianu, R. A. Vertrees, C. J. Wacker, S. J. Fuller, J. Cilley Jr., and W. A. Baldino. "Platelet-rich plasma reduces postoperative blood loss after cardiopulmonary bypass." *J Thorac Cardiovasc Surg* 100 (2 1990): 281-6.
- Drug Intelligence and Clinical Pharmacy, vol. 22, pp. 946-952, Dec. 1988, Dennis F. Thompson, et al., "Fibrin Glue: A Review of Its Preparation, Efficacy, and Adverse Effects as a Topical Hemostat".
- Edlich, Richard F., George T. Rodeheaver, and John G. Thacker. "Surgical Devices in Wound Healing Management." In *Wound Healing: Biochemical & Clinical Aspects*, ed. I. Kelman Cohen, Robert F. Diegelmann, and William J. Lindblad. 581-600. 1st ed., vol. Philadelphia: W.B. Saunders Company, 1992).
- Epstein, G. H., R. A. Weisman, S. Zwillingenberg, and A. D. Schreiber. "A new autologous fibrinogen-based adhesive for otologic surgery." *Ann Otol Rhinol Laryngol* 95 (1 Pt 1 1986): 40-5.
- First clinical results: Kuderma, H. and Helene Matras. "Die klinische Anwendung der Klebung van Nervenastomosen mit Gerinnungssubstanzen bei der Rekonstruktion verletzter peripherer Nerven." *Wein Klin Wochenschr* 87 (15 1975): 495-501.
- Galois, et al., "Cartilage Tissue Engineering: State-of-the-Art and Future Approaches," *Pathol Biol (Paris)*, 53(10), Dec. 2005.
- Gibble, J. W. and P. M. Ness. "Fibrin glue: the perfect operative sealant?" *Transfusion* 30 (Aug. 1990): 741-7.
- GPS® System, "GPS® Platelet Concentrate System," Cell Factor Technologies, Inc., Biomet Orthopaedics, Inc., (2004) (9 pages).
- GPS® System, "Shoulder Recovery with the GPS® Platelet Concentrate System, Rotator Cuff Surgical Techniques," Cell Factor Technologies, Inc., Biomet Orthopaedics, Inc., (2004) 3 pages, [http://www.cellfactortech.com/global\\_products.cfm](http://www.cellfactortech.com/global_products.cfm), printed Sep. 16, 2005.
- GPS®II System, Gravitational Platelet Separation System, "Accelerating the Body's Natural Healing Process," Cell Factor Technologies, Inc., Biomet Europe (2005) 16 pages, [http://www.cellfactortech.com/global\\_products.cfm](http://www.cellfactortech.com/global_products.cfm), printed Sep. 16, 2005.
- GPS®II System, Gravitational Platelet Separation System, "User Manual," Cell Factor Technologies, Inc., Biomet Europe [date unknown] 13 pages, [http://www.cellfactortech.com/global\\_products.cfm](http://www.cellfactortech.com/global_products.cfm), printed Sep. 16, 2005.
- Grove, et al., "Plasticity of Bone Marrow-Derived Stem Cells," *Stem Cells: Concise Review*, Jan. 22, 2004.
- Harris, E.L.V. Concentration of the Extract. In. Protein Purification Methods: A Practical Approach Harris, E.L.V.; Angal, S.; Editors. (1989) Publisher: (IRL Press, Oxford, UK), pp. 67-69.
- Hartman, A. R., D. K. Galanakis, M. P. Honig, F. C. Seifert, and C. E. Anagnostopoulos. "Autologous whole plasma fibrin gel. Intraoperative procurement." *Arch Surg* 127 (Mar. 1992): 357-9.
- Hennis, H. L., W. C. Stewart, and E. K. Jeter. "Infectious disease risks of fibrin glue [letter]." *Ophthalmic Surg* 23 (Sep. 1992): 640.
- Jackson, C. M. and Y. Nemerson. "Blood coagulation." *Annu Rev Biochem* 49 (811 1980): 765-811.
- Jorgensen, et al., "Stem Cells for Repair of Cartilage and Bone: The Next Challenge in Osteoarthritis and Rheumatoid Arthritis," *Annals of Rheumatic Diseases*, Aug. 2000.
- Journal of Oral Maxillofacial Surgery, vol. 43, pp. 605-611, 1985, Helene Matras, M.D., "Fibrin Seal: The State of the Art".
- Karpatkin, S., "Heterogeneity of Human Platelets. VI., Correlation of Platelet Function with Platelet Volume", *Blood*, vol. 51, No. 2 (Feb. 1978).
- Kjaergard, H. K., U. S. Weis-Fogh, H. Sorensen, J. Thiis, and I. Rygg. "A simple method of preparation of autologous fibrin glue by means of ethanol." *Surg Gynecol Obstet* 175 (1 1992): 72-3.
- Kjaergard, H. K., Fogh Us Weis, and J. J. Thiis. "Preparation of autologous fibrin glue from pericardial blood." *Ann Thorac Sur* 55 (Feb. 1993): 543-4.
- Laryngoscope vol. 99, pp. 974-976, Sep. 1989, Kyosti Laitakari, M.D., et al., "Autologous and Homologous Fibrinogen Sealants: Adhesive Strength".
- Laryngoscope, vol. 95, pp. 1074-1076, Sep. 1985, Karl H. Siedentop, M.D., et al., "Autologous Fibrin Tissue Adhesive".
- Laryngoscope, vol. 96, pp. 1062-1064, Oct. 1986, Karl H. Siedentop, M.D., et al., "Extended Experimental and Preliminary Surgical Findings with Autologous Fibrin Tissue Adhesive Made from Patient's Own Blood".
- Lasher, Lisa, M.D., "My Experience with PRP," PowerPoint presentation, [http://www.cellfactortech.com/global\\_products.cfm](http://www.cellfactortech.com/global_products.cfm), printed Sep. 16, 2005.
- Lerner, R. and N. S. Binur. "Current status of surgical adhesives." *J Surg Res* 48 (Feb. 1990): 165-81.
- Lu, et al., "Bone Marrow Mesenchymal Stem Cells: Progress in Bone/Cartilage Defect Repair," 19(1), Jan. 2002.
- Matras, Helene, H. P. Dinges, H. Lassmann, and B. Mamoli. "Zur nahtlosen interfazikularen Nervenreplantation im Tierexperiment." *Wein Med Wochenschr* 122 (37 1972): 517-523.
- Minntech® Filtration Technologies Group, "Hemocor HPH® Hemoconcentrator," Minntech Corporation (2004); <http://www.minntech.com/ftg/products/hph/index.html>, printed Jul. 15, 2004 (2 pages).
- Minntech® Filtration Technologies Group, "Medical Applications: Blood Filtration" Minntech Corporation (2004); [http://www.minntech.com/ftg/industries/medical/blood\\_filter.html](http://www.minntech.com/ftg/industries/medical/blood_filter.html), printed Jul. 15, 2004 (1 page).
- Minntech® Filtration Technologies Group, "Renaflo® II Hemofilter," Minntech Corporation (2004); <http://www.minntech.com/ftg/products/renaflo/index.html>, printed Jul. 15, 2004 (2 pages).

- Molnar, Amy, "Stem Cells from Muscles Can Repair Cartilage, Study Finds Genetically Engineered Muscle-Derived Stem Cells Improved Cartilage Repair in Rats", American College of Rheumatology, (2005).
- Moretz, W., Jr., J. Shea Jr., J. R. Emmett, and J. Shea. "A simple autologous fibrinogen glue for otologic surgery." *Otolaryngol Head Neck Surg* 95 (Jan. 1986): 122-4.
- Nilsson, et al., "Bone Repair Induced by Bone Morphogenetic Protein in Ulnar Defects in Dogs," The Journal of Bone and Joint Surgery, vol. 68 B., No. 4, Aug. 1986.
- Otolaryngologic Clinics of North America, vol. 27, No. 1, pp. 203-209, Feb. 1994, Dean M. Toriumi, M.D., et al., "Surgical Tissue Adhesives in Otolaryngology-Head and Neck Surgery".
- Ponticciello, Michael S., "A Rapid Technique for the Isolation and Concentration of Stem Cells from Human Bone Marrow", Cell Factor Technologies, Inc. (undated) 1 page.
- Sanal, M. "Does fibrin glue cause foreign body reactions? [letter]." *Eur J Pediatr Surg* 3 (Mar. 1993): 190.
- Sanal, M., H. Dogruyol, A. Gurpinar, and O. Yerci. "Does fibrin glue cause foreign body reactions?" *Eur J Pediatr Surg* 2 (May 1992): 285-6.
- Schmidt, K.G., et al., "Labelling of Human and Rabbit Platelets with Indium-Oxine Complex", 23:97-106 (1979).
- Schmidt, K.G., et al., "Preparation of Platelet Suspensions from Whole Blood in Buffer", *Scand. J. Hoemato*, 23:88-96 (1979).
- Sierra, D. H. "Fibrin sealant adhesive systems: a review of their chemistry, material properties and clinical applications." *J Biomater Appl* 7 (4 1993): 309-52.
- Swift, Mathew J., et al., "Characterization of Growth Factors in Platelet Rich Plasma," 1-Cell Factor Technologies, [http://www.cellfactortech.com/global\\_products.cfm](http://www.cellfactortech.com/global_products.cfm), printed Sep. 16, 2005.
- The American Journal of Surgery, vol. 168, pp. 120-122, Aug. 1994, Roy L. Tawes, Jr., M.D., et al., "Autologous Fibrin Glue: The Last Step in Operative Hemostatis".
- The American Surgeon, vol. 55, pp. 166-168, Mar. 1989, William D. Spotnitz, M.D., et al., "Successful Use of Fibrin Glue During 2 Years of Surgery at a University Medical Center".
- The Sports Medicine Center, "Knee Cartilage Implantation", Carticel™, "Autologous Cultured Chondrocyte Implantation", <http://www.orthoassociates.com/carticel.htm> (printed Apr. 6, 2006).
- The Stone Clinic, "Platelet Rich Plasma (PRP)", web site printed May 2006.
- Vox Sanguinis, vol. 68: 82-89, Feb. 1995, Boomgaard et. al, Pooled Platelet Concentration Prepared by the . . . .
- Weis-Fogh, U. S. "Fibrinogen prepared from small blood samples for autologous use in a tissue adhesive system." *Eur Surg Res* 20 (May 6, 1988): 381-9.
- Wiseman, David M., David T. Rovee, and Oscar M. Alvarez. "Wound Dressings: Design and Use." In *Wound Healing: Biochemical & Clinical Aspects*, ed. I. Kelman Cohen, Robert F. Diegelmann, and William J. Lindblad. 562-580. 1st ed., vol. Philadelphia: W. B. Saunders Company, 1992).
- "Cell Isolation Techniques, Methods and Materials, Working with Enzymes," (2004) (9 pages) Worthington Biochemical Corp.
- "Cell Isolation Theory, Tissue Types," (2004) (5 pages) Worthington Biochemical Corp.
- "Cytori Celution Cell Concentrate Device," Exhibit 14, 510(k) Summary, FDA approval K060482 (Sep. 28, 2006).
- "Frequently Asked Questions, 1. Kits, 2. Enzymes," (2003) 3 pages Worthington Biochemical Corp.
- "Trypsinization of Adherent Cells," (undated) 2 pages.
- DeUgarte, M.D., Daniel A., et al., "Future of Fat as Raw Material for Tissue Regeneration," (2007) pp. 215-219, Lippincott Williams & Wilkins, Inc.
- DiMuzio, Paul et al., "Development of a Tissue-Engineered Bypass Graft Seeded with Stem Cells," *Vascular*, vol. 14, No. 6, (2006) pp. 338-342, BC Decker, Inc.
- Frasier, John K., et al., "Plasticity of human adipose stem cells toward endothelial cells and cardiomyocytes," *Nature Clinical Practice Cardiovascular Medicine*, vol. 3, Supplement 1 (Mar. 2006) pp. S33-S37.
- Gimble, Jeffrey M., "Adipose-Derived Stem Cells for Regenerative Medicine," *Circulation Research* (2007) pp. 1249-1260, American Heart Association, Inc.
- Gomillion, Cheryl T., et al., "Stem cells and adipose tissue engineering," *Biomaterials* 27, Science Direct (2006) pp. 6052-6063, Elsevier.
- Guilak, Frank, et al., "Adipose-derived adult stem cells for cartilage tissue engineering," *Biorheology* 41 (2004) pp. 389-399, IOS Press.
- Hattori, et al., "Osteogenic Potential of Human Adipose Tissue-Derived Stromal Cells as an Alternative Stem Cell Source," *Cells Tissues Organs* (2004) 178:2-12 Karger.
- International Preliminary Report on Patentability completed Aug. 13, 2009 for PCT/US2008/004687 claiming benefit of U.S. Appl. No. 60/911,407, filed Apr. 12, 2007.
- International Search Report and Written Opinion mailed Jul. 3, 2009 for PCT/US2009/035564 claiming benefit of U.S. Appl. No. 61/078,178, filed Jul. 3, 2008.
- Lendeckel, Stefan, et al., "Autologous stem cells (adipose) and fibrin glue used to treat widespread traumatic calvarial defects: case report," *Journal of Cranio-Maxillofacial Surgery* (2004) European Association for Cranio-Maxillofacial Surgery.
- Nakagami, Hironori, et al., "Novel Autologous Cell Tehrapy in Ischemic Limb Disease Through Growth Factor Secretion by Cultured Adipose Tissue-Derived Stromal Cells," *Angiogenesis by Adipose Tissue-Derived Cells*, (2005) pp. 2542-2547, American Heart Association, Inc.
- Nathan, Suresh., et al., "Cell-Based Therapy in the Repair of Osteochondral Defects: A Novel Use for Adipose Tissue," *Tissue Engineering*, vol. 9, No. 4 (2003) pp. 733-744 Mary Ann Liebert, Inc.
- Parker, Anna M., et al., Adipose-derived stem cells for the regeneration of damaged tissues, Expert Opinion, Cell- & Tissue-based Therapy, Expert Opin. Biol. Ther. (2006) pp. 567-578 Informa UK Ltd.
- Planat-Bénard, V., et al., "Spontaneous Cardiomyocyte Differentiation From Adipose Tissue Stroma Cells," *Adipose-Derived Cell Cardiomyocyte* (2004) pp. 223-229 American Heart Association, Inc.
- Rangappa, Sunil, M.D., "Transformation of Adult Mesenchymal Stem Cells Isolated From the Fatty Tissue Into Cardiomyocytes," *Adult Stem Cells Transformed into Cardiomyocytes*, (2003) pp. 775-779 Ann Thorac Surg.
- Rigotti, M.D., et al., "Clinical Treatment of Radiotherapy Tissue Damage by Lipoaspirate Transplant: A Healing Process Mediated by Adipose-Derived Adult Stem Cells," *Plastic and Reconstructive Surgery*, Breast, PRS Journal vol. 119, No. 5, Stem Cell Therapy for Angiogenesis, (Pub. 2005) pp. 1409-1422.
- Rubin, M.D., et al., "Clinical Treatment of Radiotherapy Tissue Damage by Lipoaspirate Transplant: A Healing Process Mediated by Adipose-Derived Adult Stem Cells," *Plastic and Reconstructive Surgery*, Discussion vol. 119, No. 5, Stem Cell Therapy for Angiogenesis, (2007) pp. 1423-1424.
- Schäffler, Andreas, et al., "Concise Review: Adipose Tissue-Derived Stromal Cells—Basic and Clinical Implications for Novel Cell-Based Therapies," *Tissue-Specific Stem Cells, Stem Cells®* (2007) pp. 818-827 AlphaMed Press.
- Sigma-Aldrich® Alkaline Phosphatase (Procedure No. 85), drug fact sheet, (2003) pp. 1-2, Sigma-Aldrich, Inc.
- Takahashi, Kazutoshi et al., "Induction of Pluripotent Stem Cells from Adult Human Fibroblasts by Defined Factors," *Cell*, (2007) pp. 1-12, Elsevier Inc.
- Yoon, Eulsik, M.D., Ph.D., et al., "In Vivo Osteogenic Potential of Human Adipose-Derived Stem Cells/Poly Lactide-Co-Glycolic Acid Constructs for Bone Regeneration in a Rat Critical-Sized Calvarial Defect Model," *Tissue Engineering*, vol. 13, No. 3 (2007) pp. 619-627 Mary Ann Liebert, Inc.
- Zhang, Duan-zhen, et al., "Transplantation of autologous adipose-derived stem cells ameliorates cardiac function in rabbits with myocardial infarction," *Chinese Medical Journal*, vol. 120, No. 4 (2007) pp. 300-307 General Hospital of Shenyang Military Region, Shenyang, China.
- Zuk, Patricia A., Ph.D., "Multilineage Cells from Human Adipose Tissue: Implications for Cell-Based Therapies," *Tissue Engineering*, vol. 7, No. 2, (2001) pp. 211-228 Mary Ann Liebert, Inc.

Coller, et al., "The pH Dependence of Quantitative Ristocetin-Induced Platelet Aggregation: Theoretical and Practical Implications—A New Device for Maintenance of Platelet-Rich Plasma pH, Blood," vol. 47, No. 5 (May 1976).  
Harvest SmartPrep PRP-20 Procedure Pack, "Instructions for Use".

Harvest Technologies Brochure, SmartPreP 2 (2002).  
Symphony II Platelet Concentrate System/PCS Brochure; DePuy (Jan. 2003).

\* cited by examiner

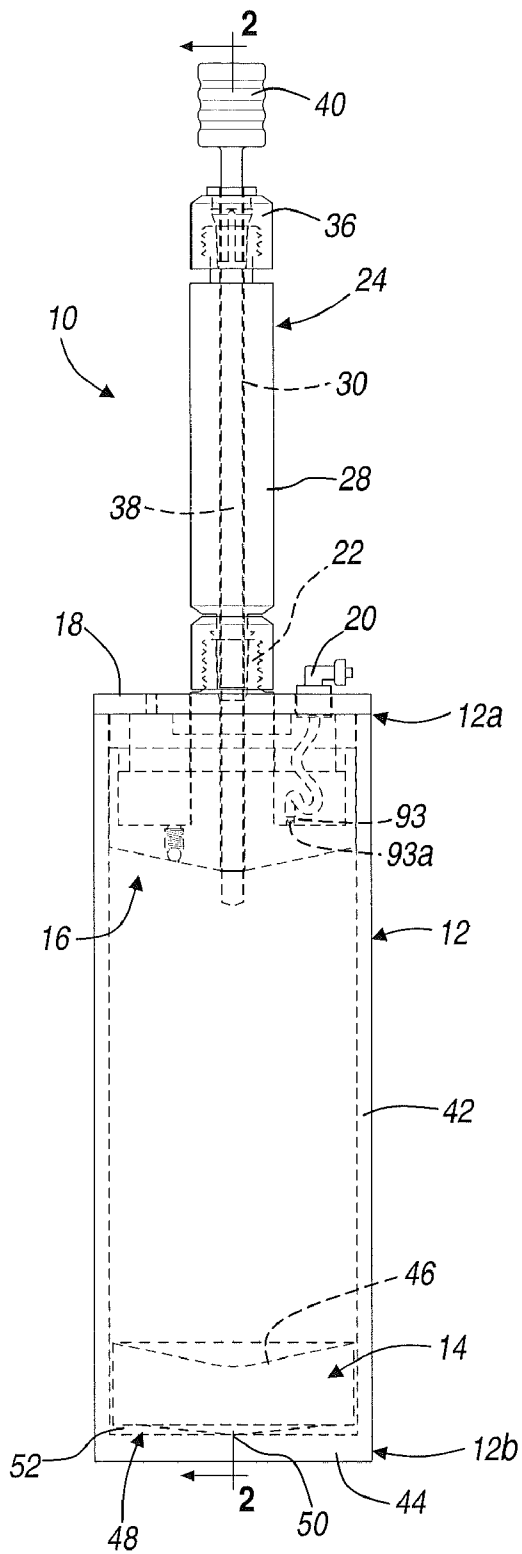

FIGURE 1

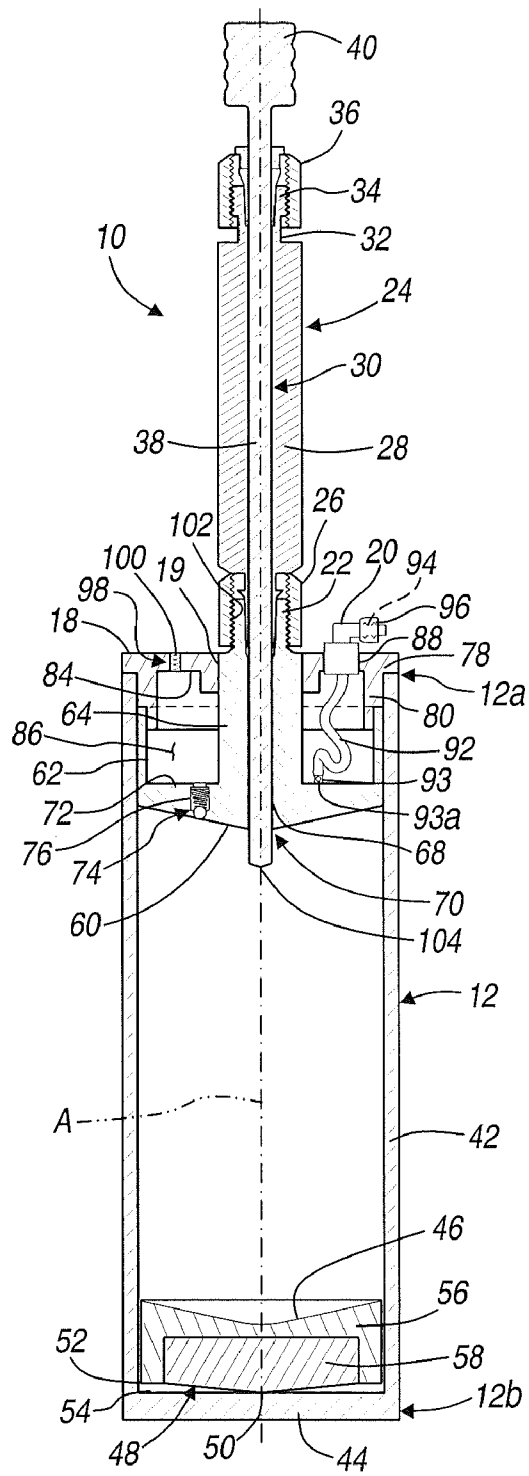
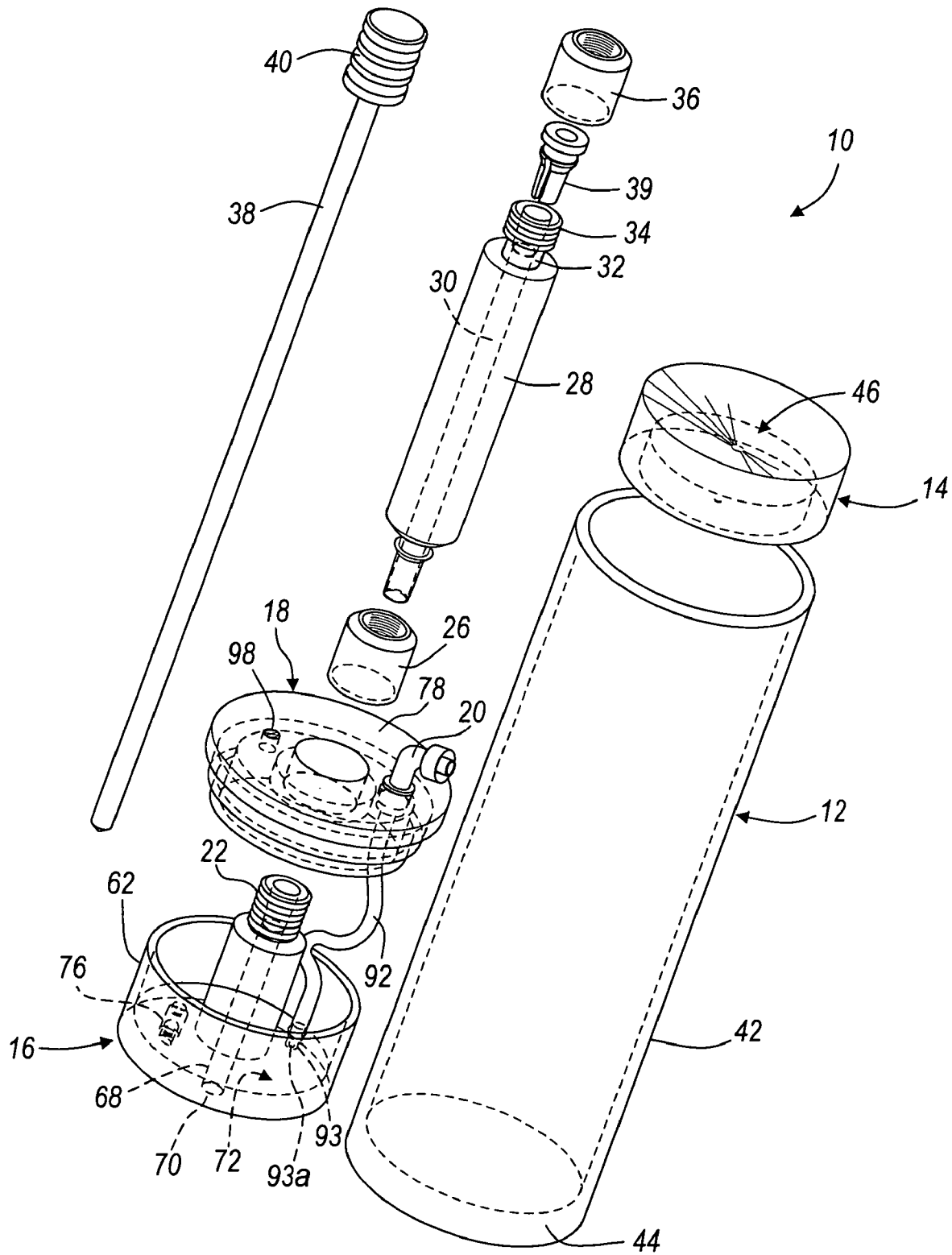

FIGURE 2





**FIGURE 3**

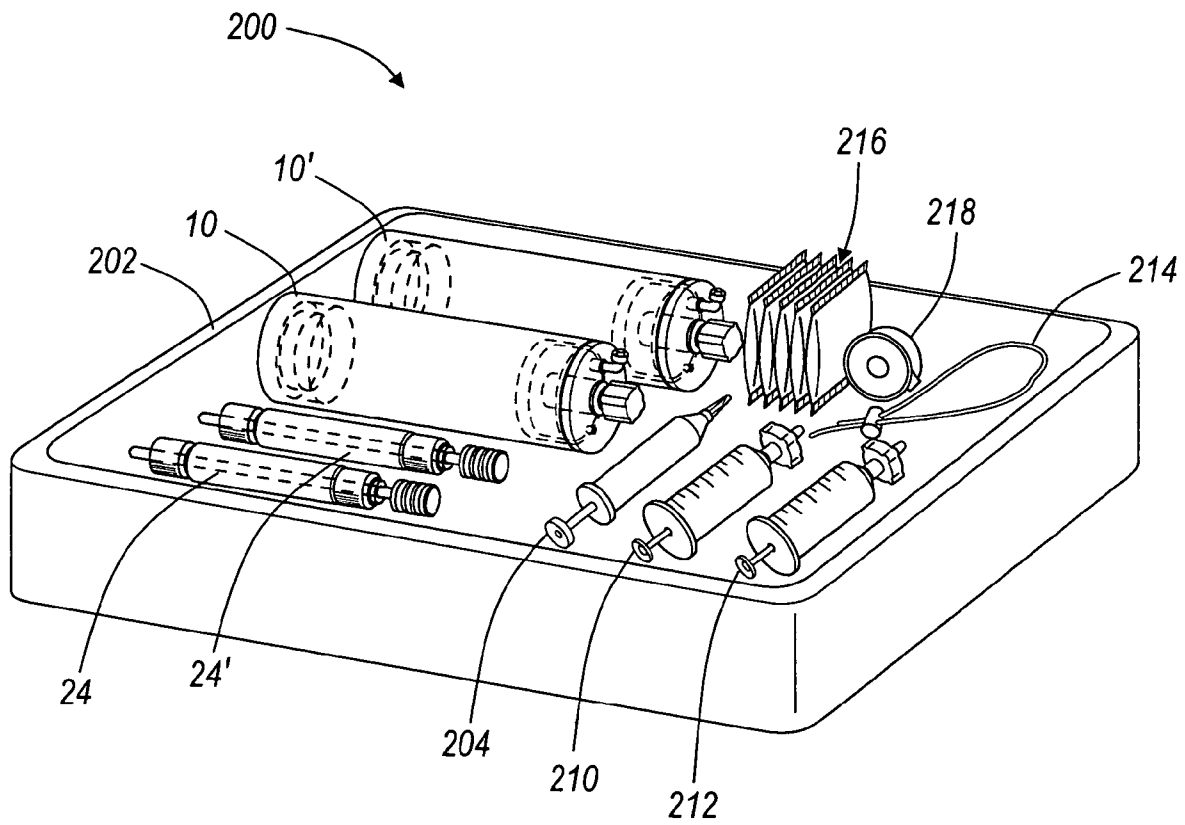

FIGURE 4

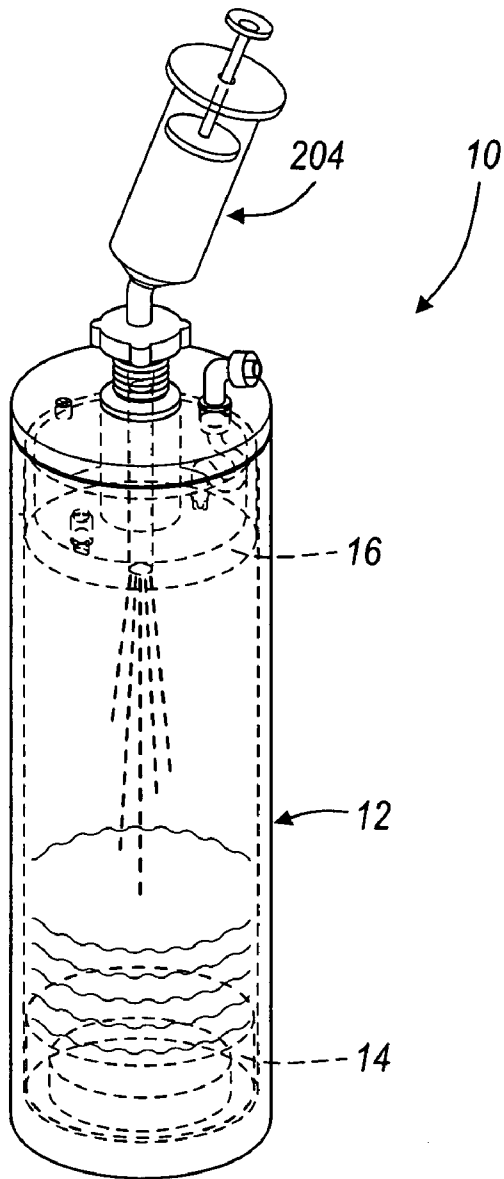

FIGURE 5A

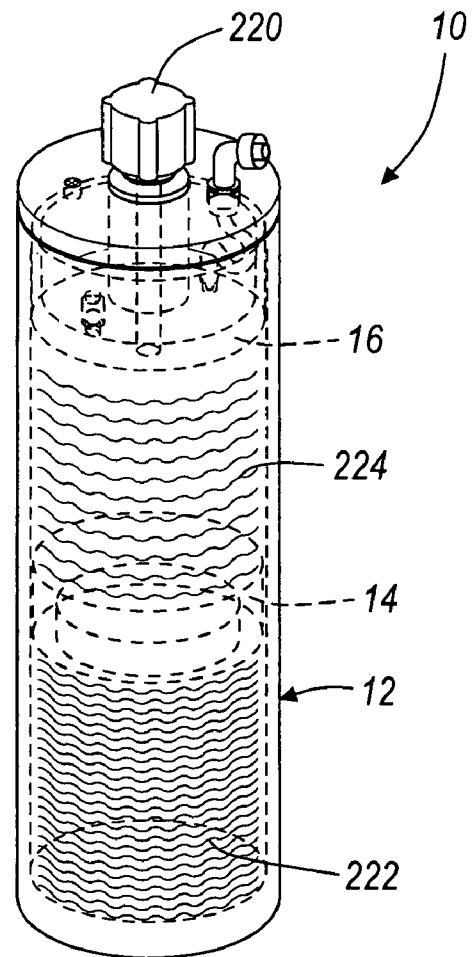

FIGURE 5B

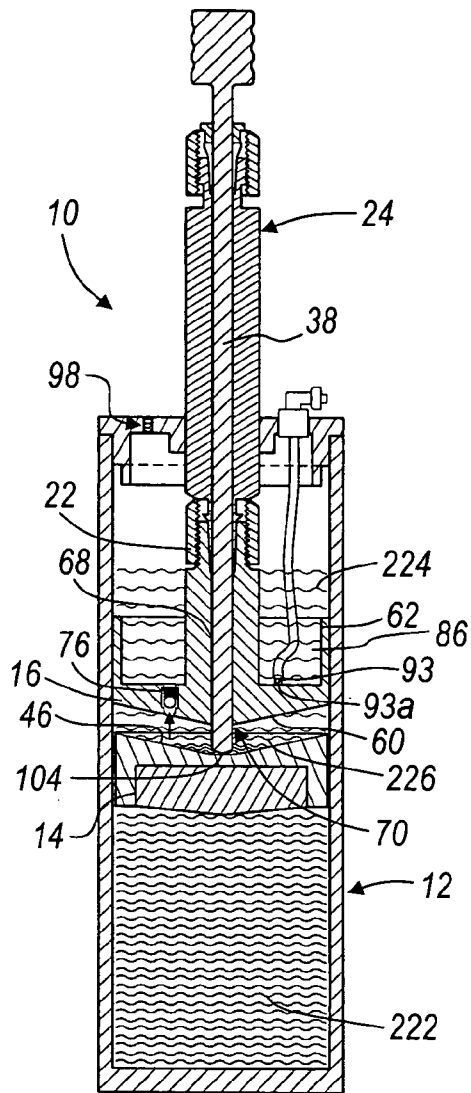

FIGURE 5C

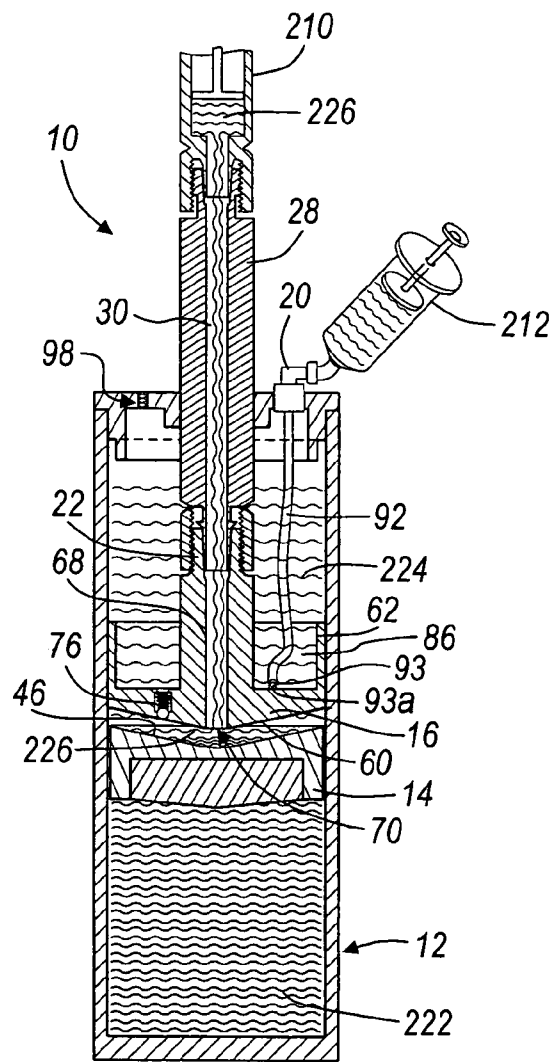

FIGURE 5D

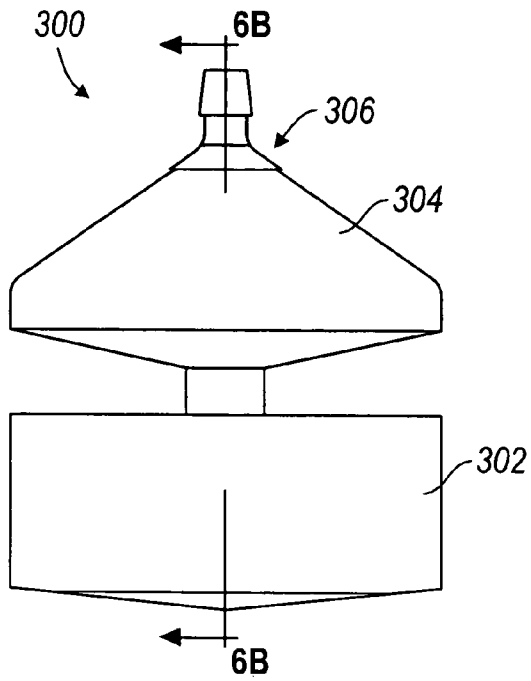

FIGURE 6A

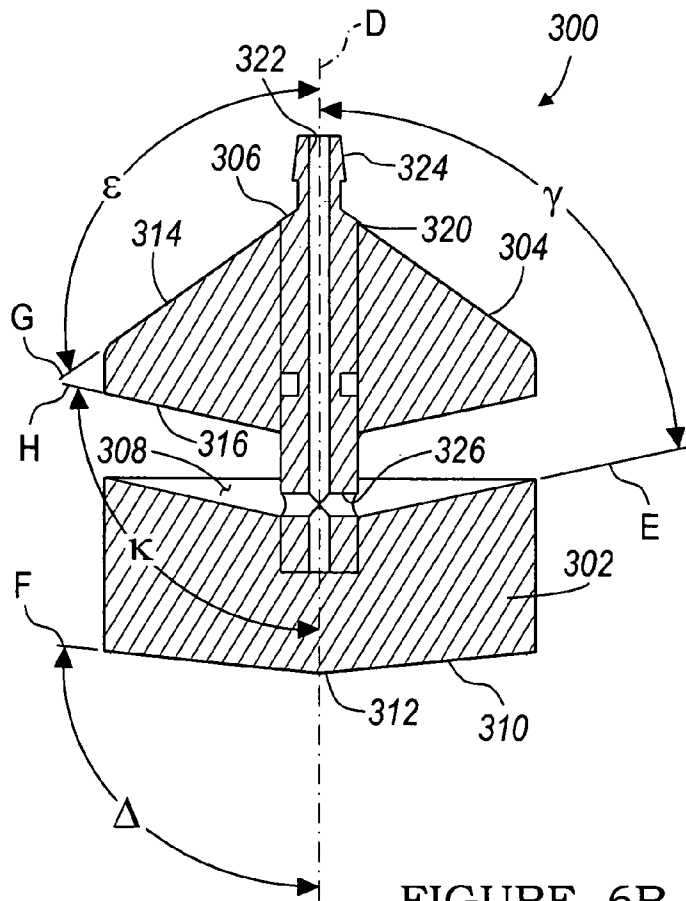

FIGURE 6B

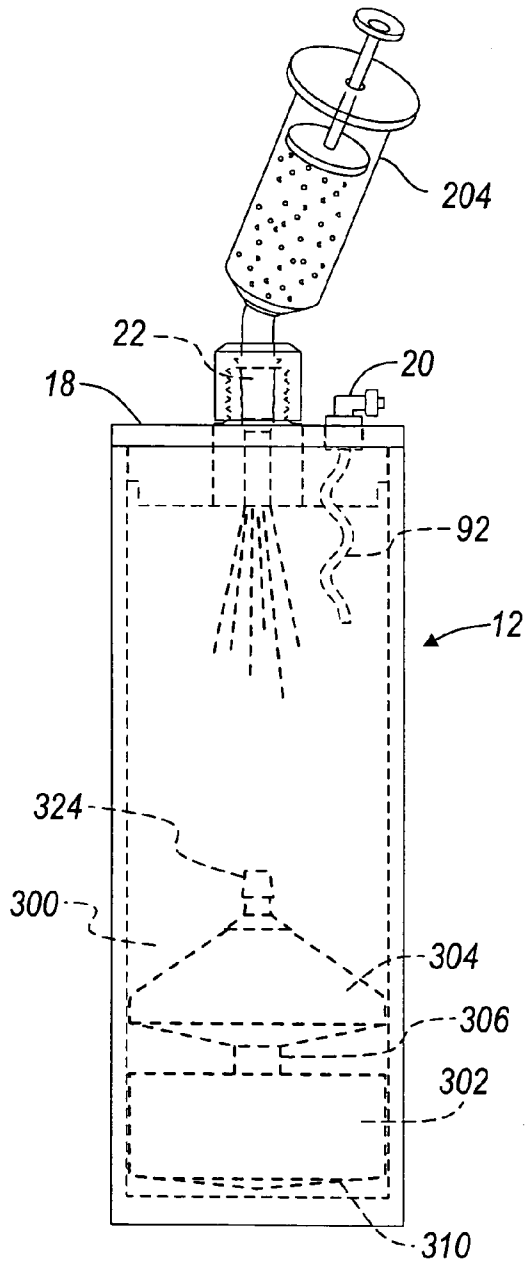

FIGURE 7A

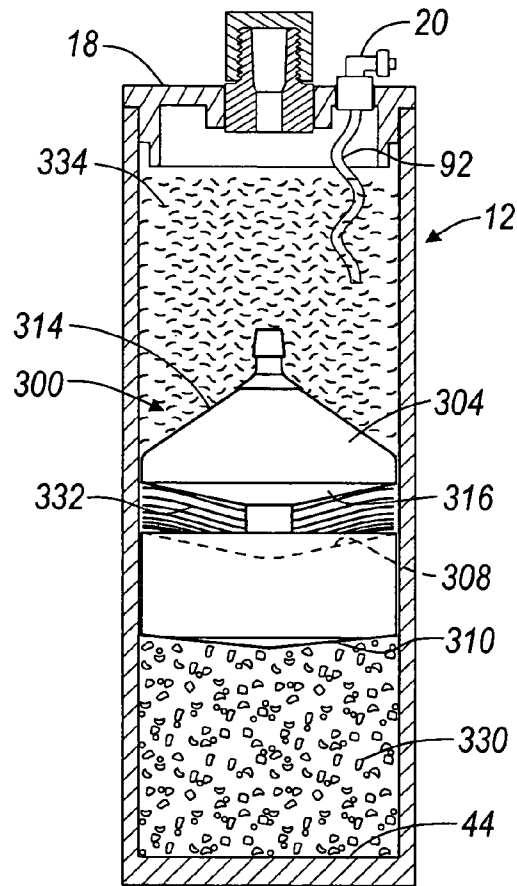

FIGURE 7B

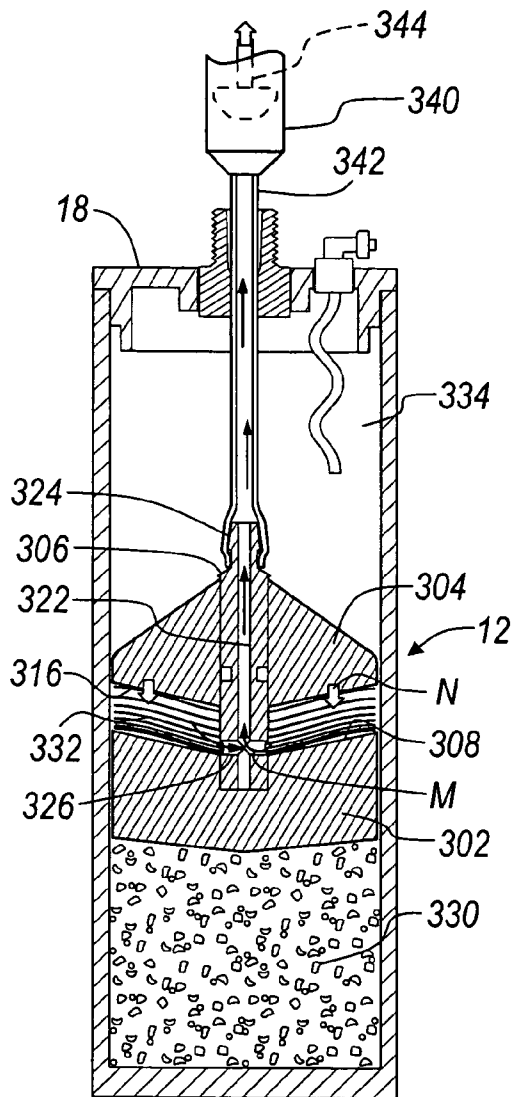

FIGURE 7C

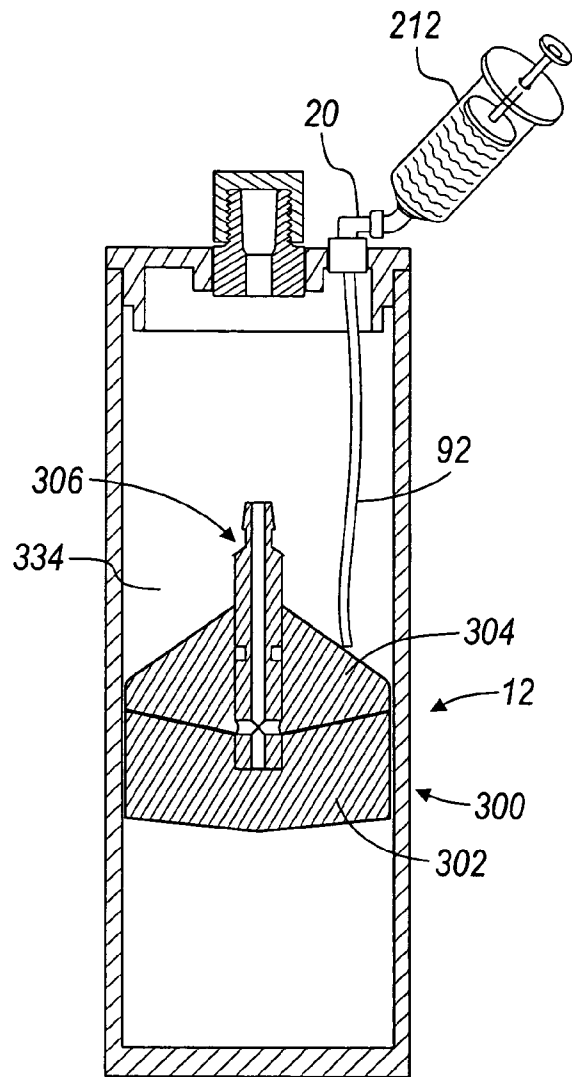
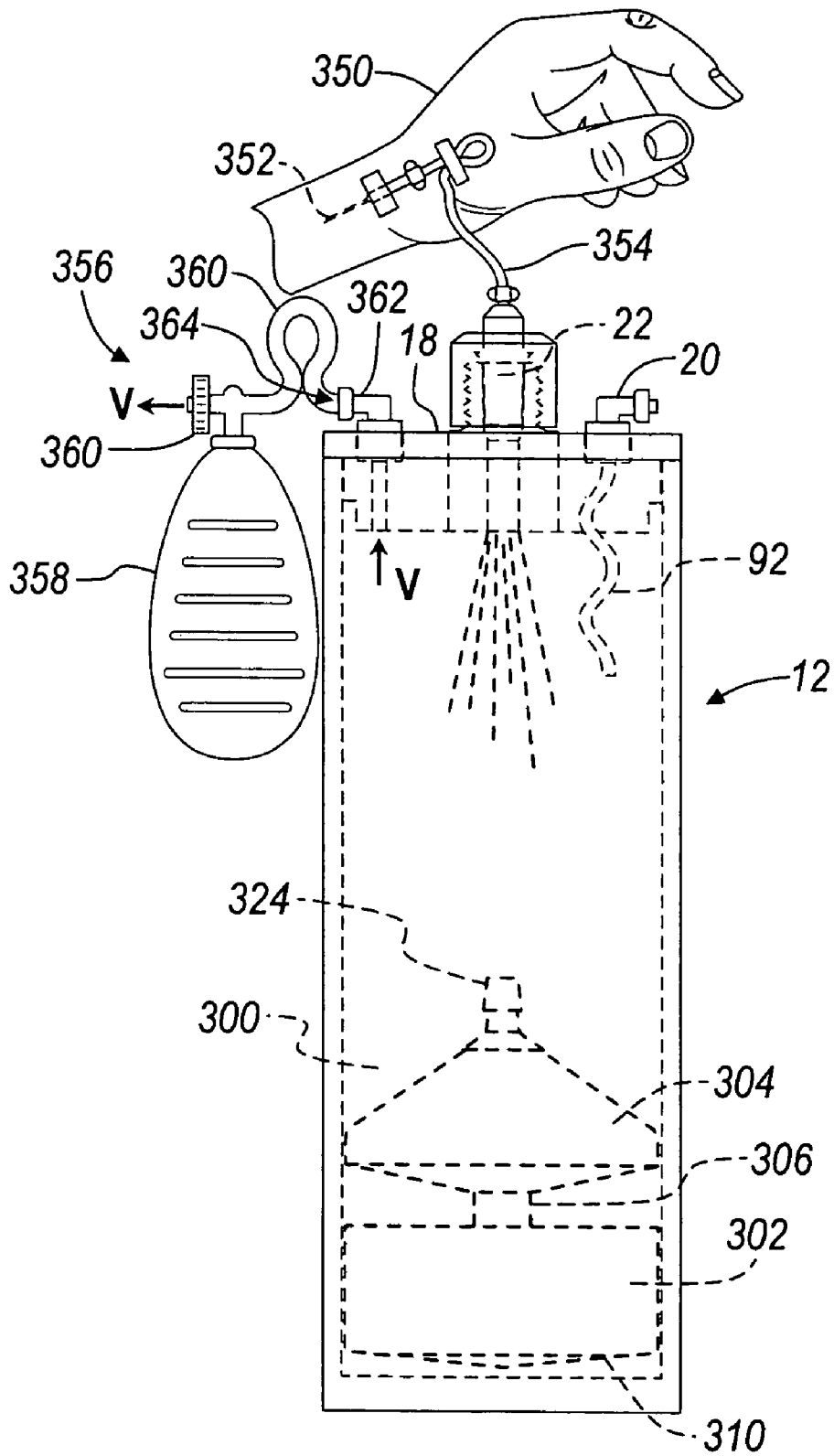

FIGURE 7D



**FIGURE 8**



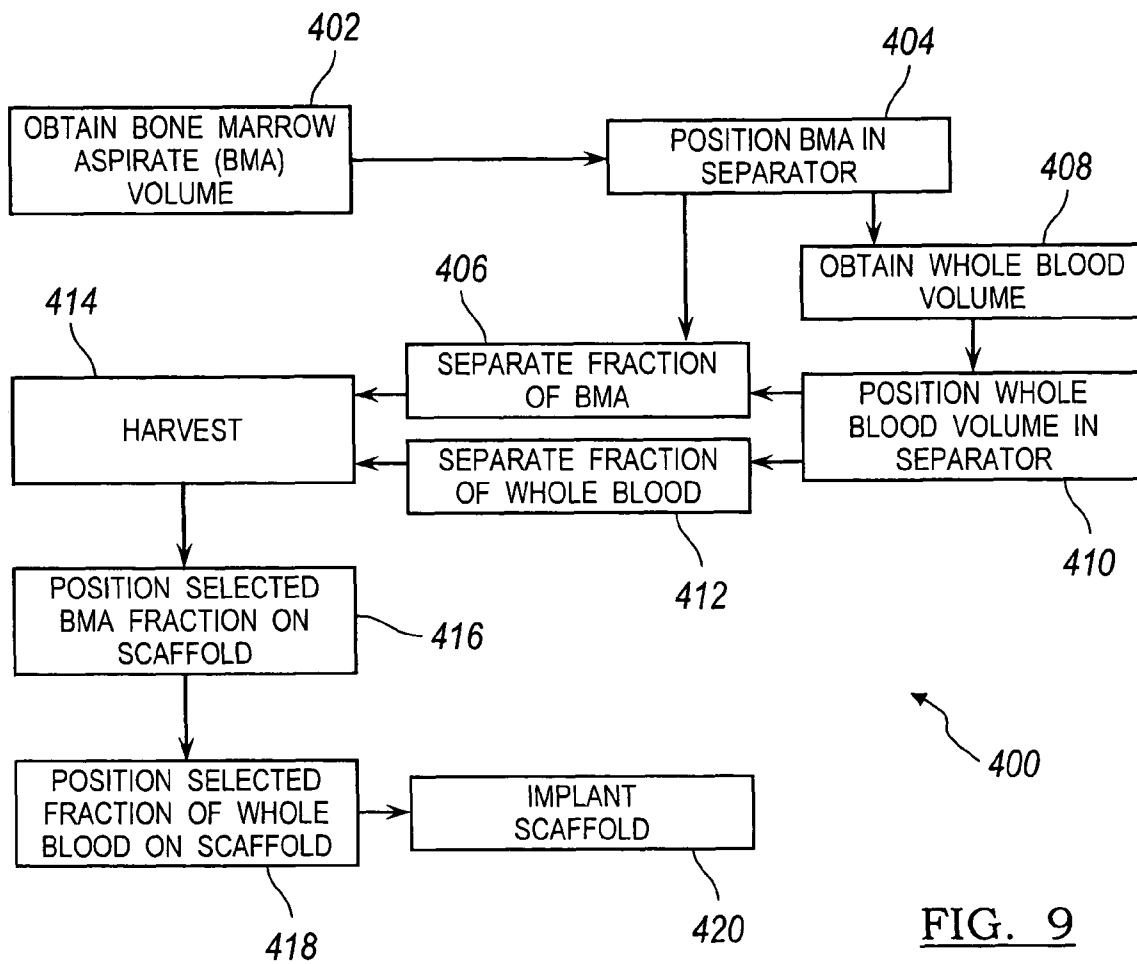

FIG. 9

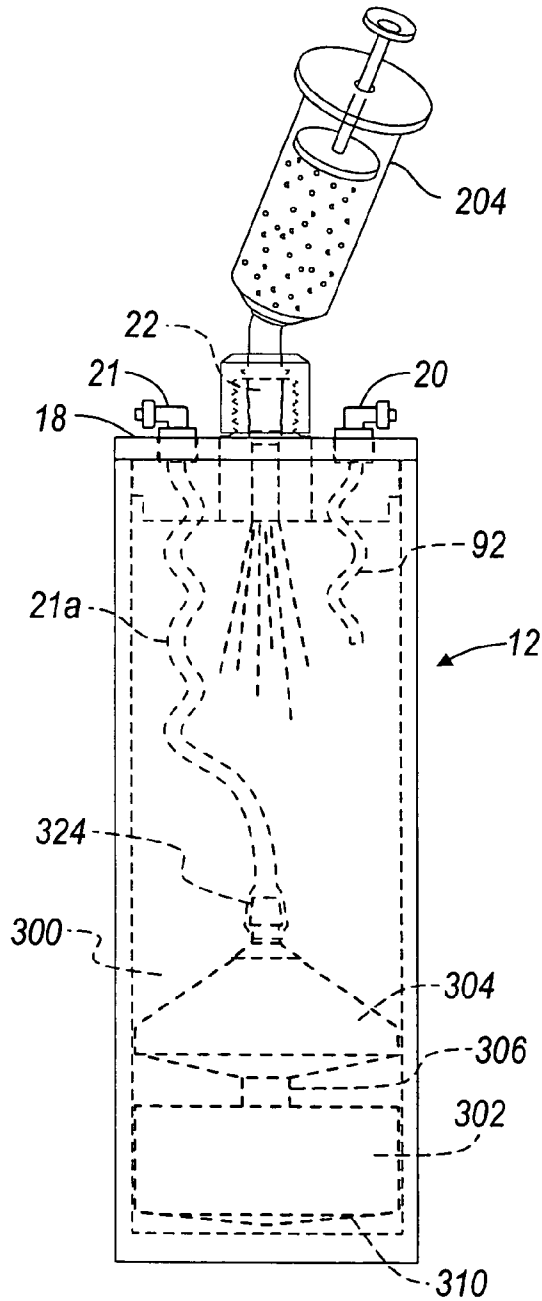

FIGURE 10A

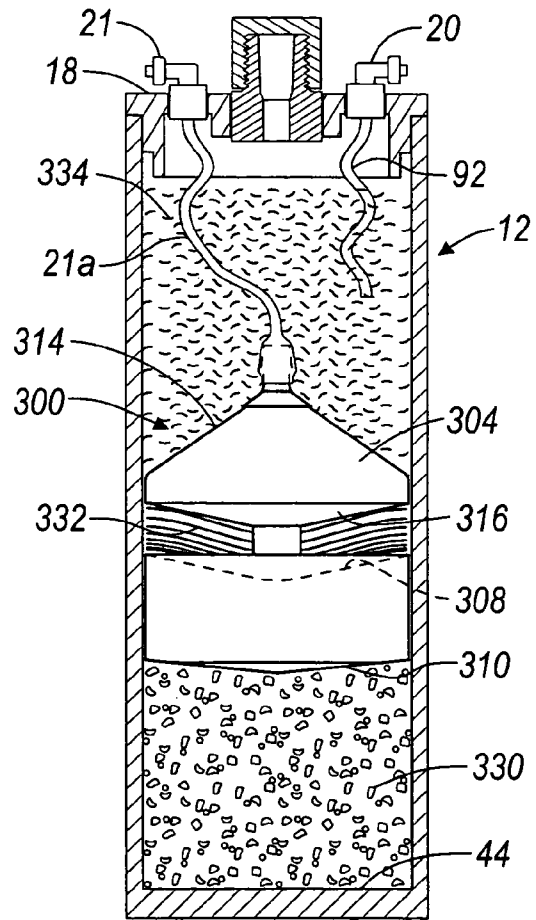
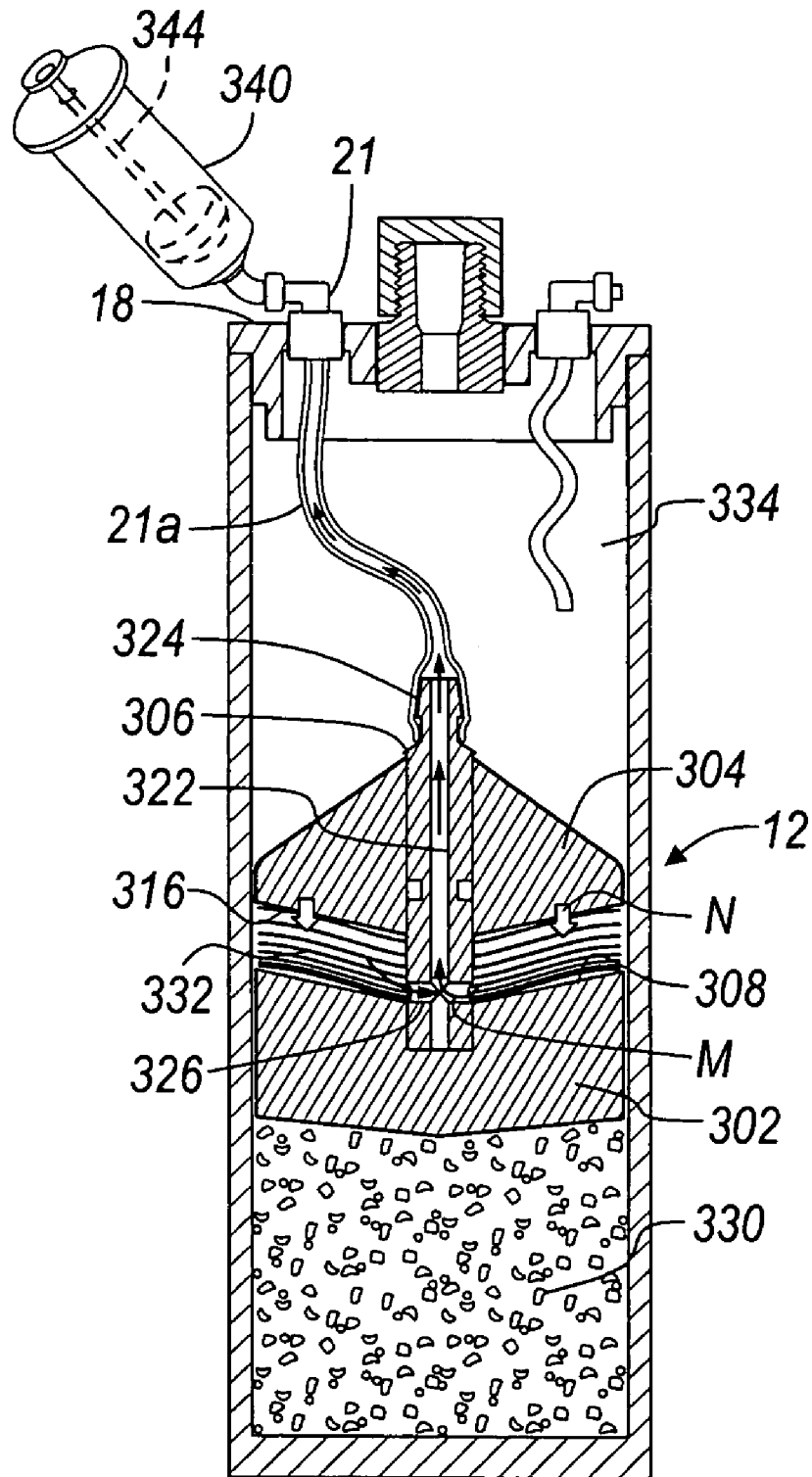

FIGURE 10B



**FIGURE 10C**

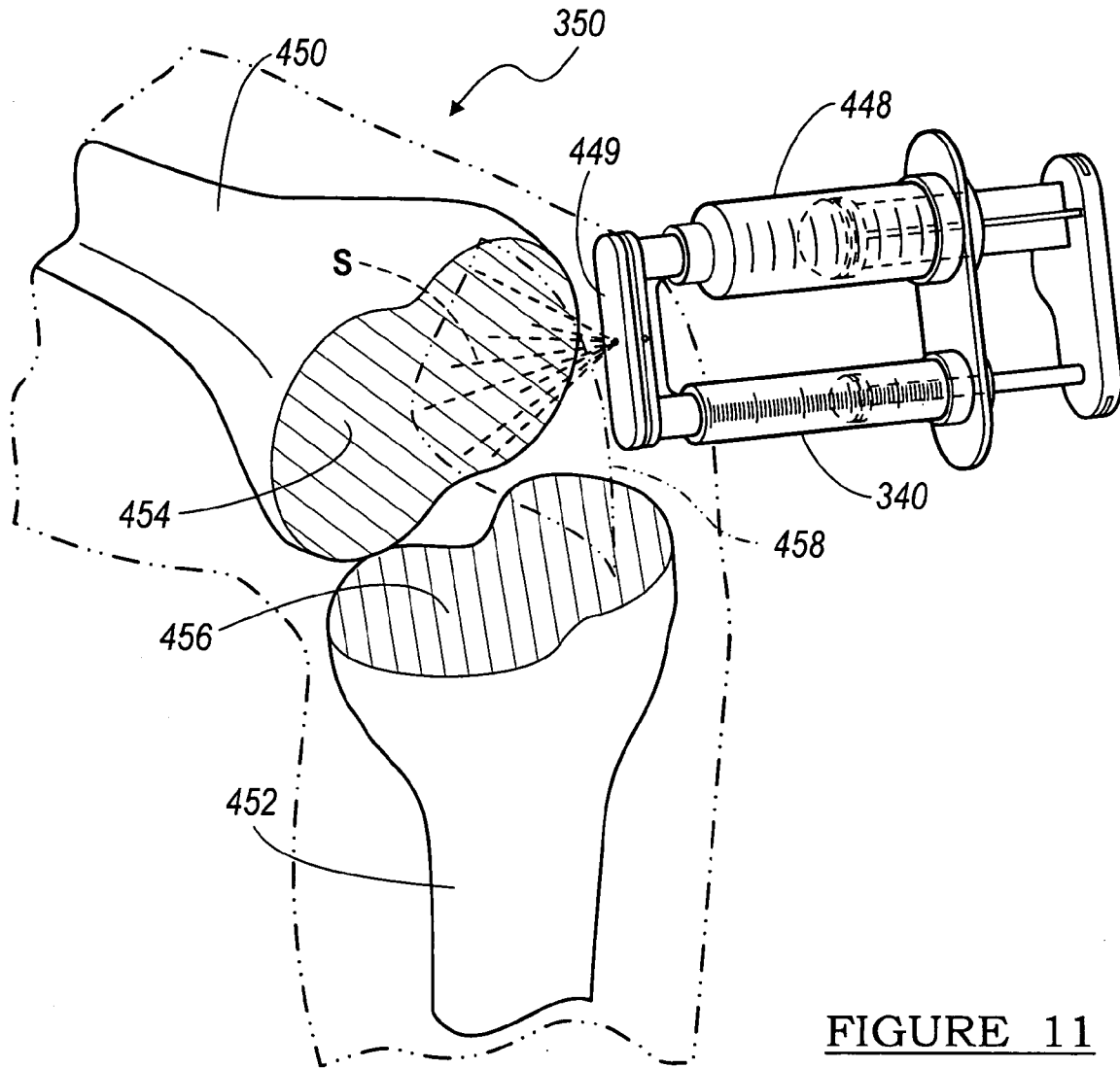

FIGURE 11

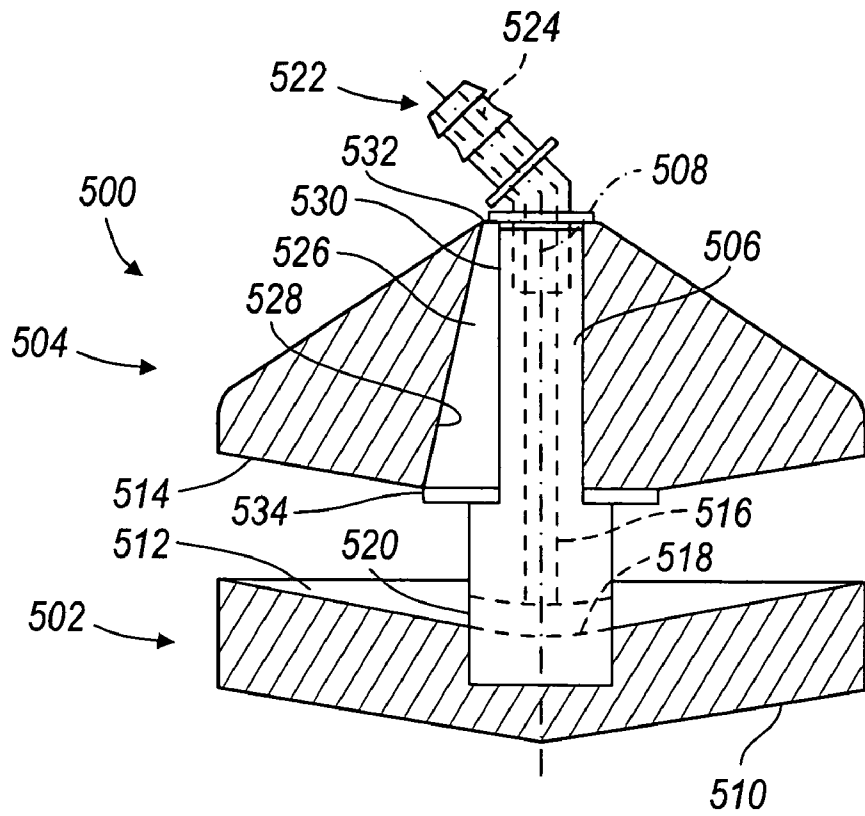

FIGURE 12

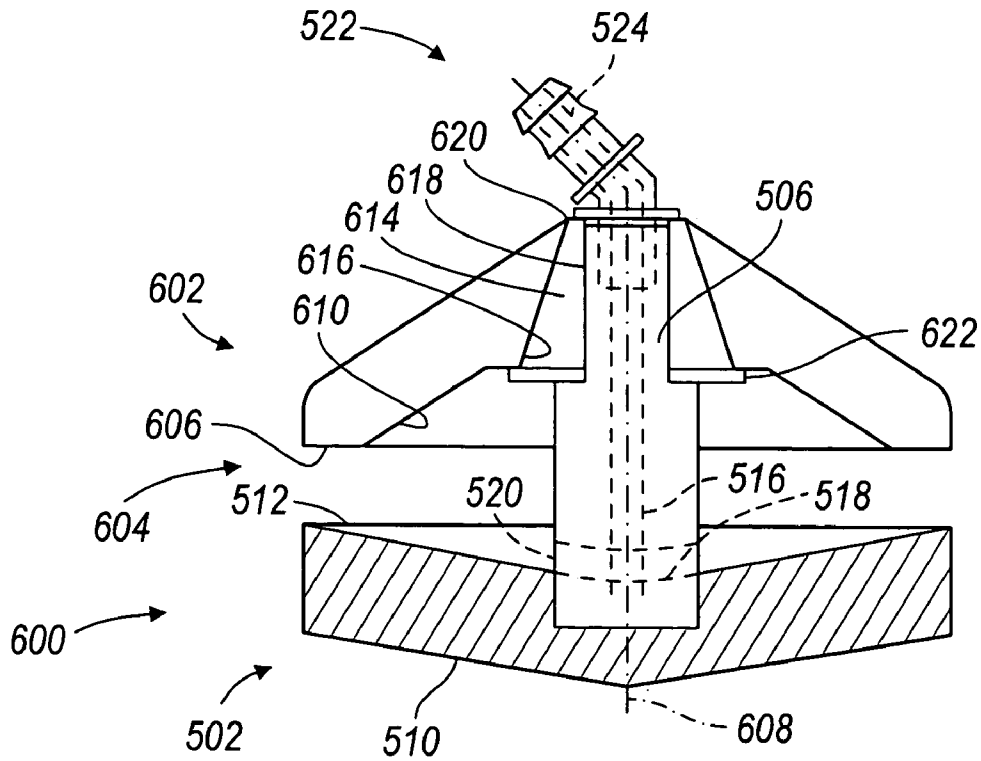

FIGURE 13

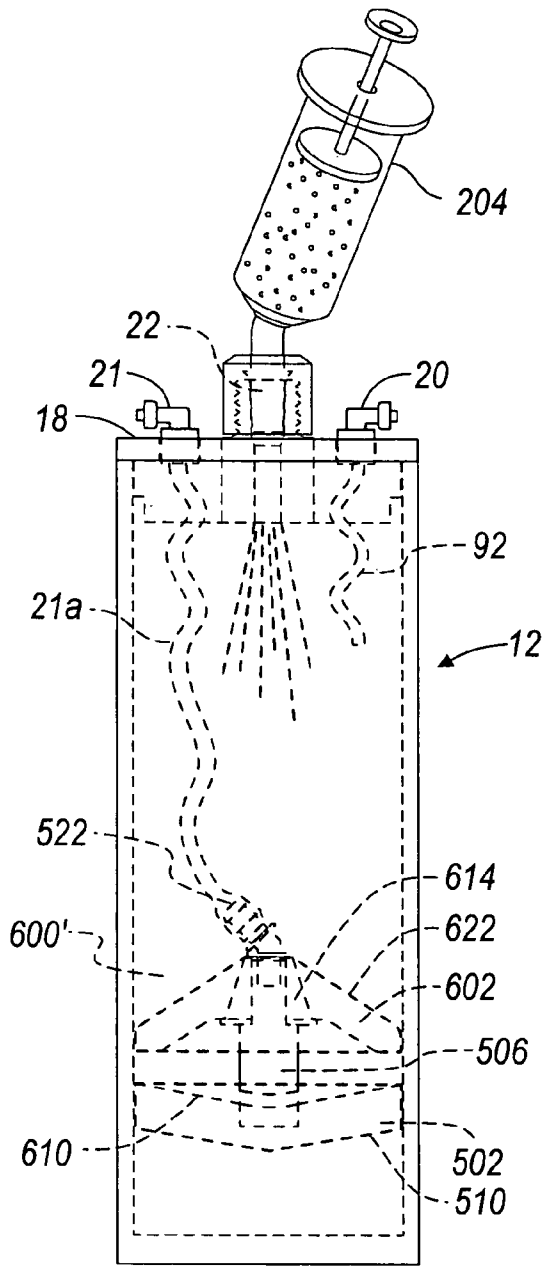

FIGURE 14A

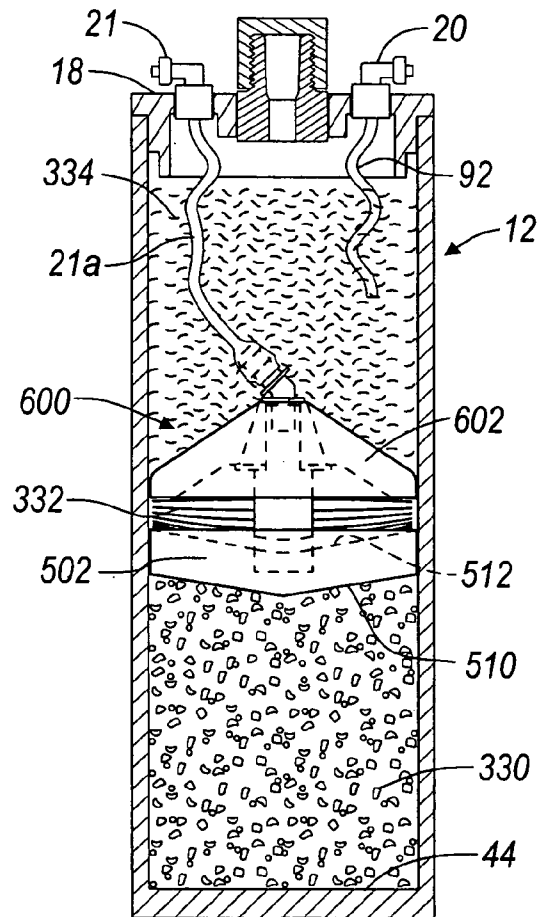
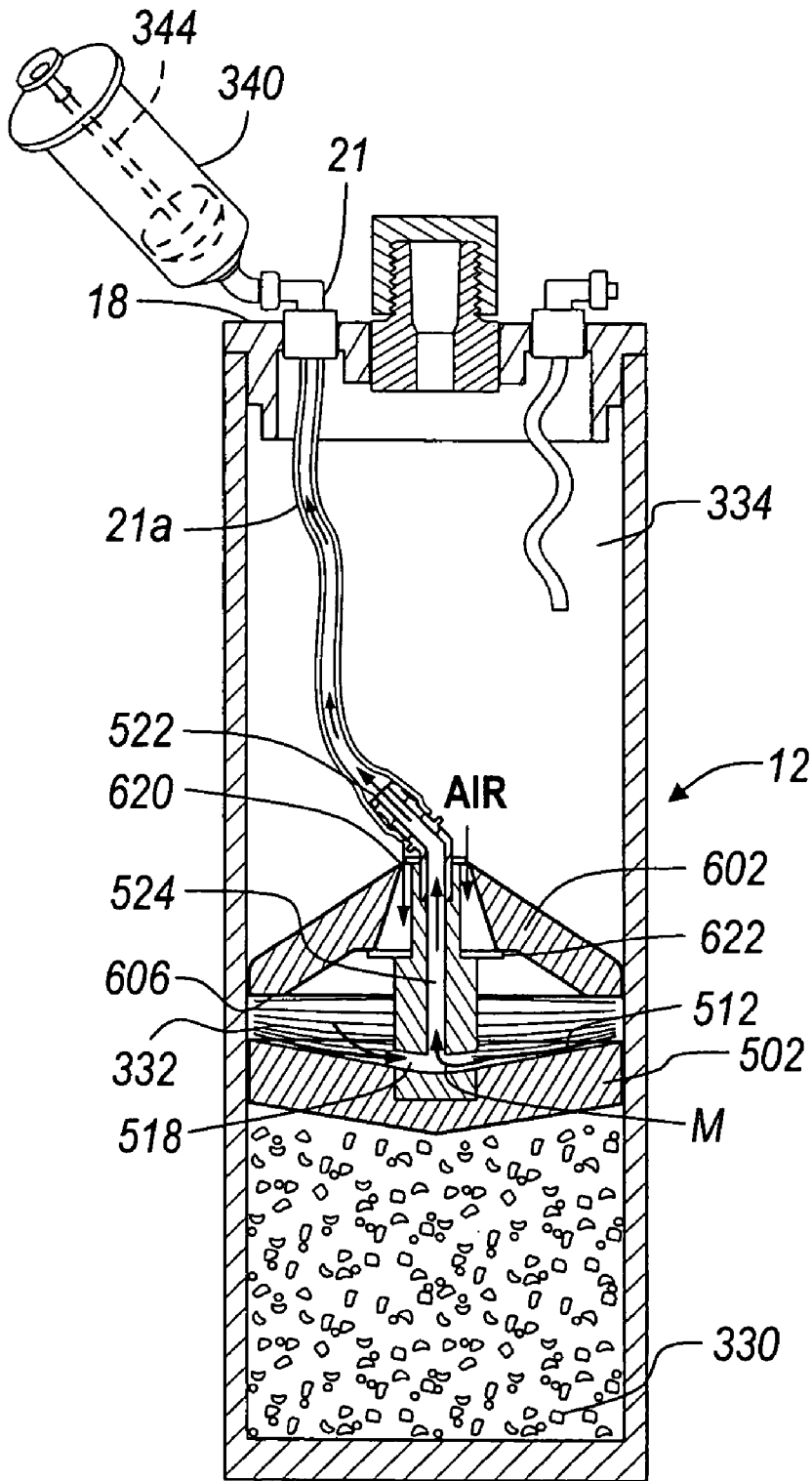

FIGURE 14B



**FIGURE 14C**

**APPARATUS AND METHOD FOR  
SEPARATING AND CONCENTRATING  
FLUIDS CONTAINING MULTIPLE  
COMPONENTS**

CROSS-REFERENCE TO RELATED  
APPLICATIONS

This application is a continuation-in-part of U.S. patent application Ser. No. 10/932,882, filed Sep. 2, 2004, entitled "APPARATUS AND METHOD FOR SEPARATING AND CONCENTRATING FLUIDS CONTAINING MULTIPLE COMPONENTS", which is a continuation-in-part of U.S. patent application Ser. No. 10/445,381, filed May 23, 2003, entitled "APPARATUS AND METHOD FOR SEPARATING AND CONCENTRATING FLUIDS CONTAINING MULTIPLE COMPONENTS" that claimed the benefit of U.S. Provisional Application No. 60/383,013, filed on May 24, 2002. The disclosures of the above applications are incorporated herein by reference.

FIELD

The present teachings relate to a multiple component fluid and a concentrator/separator, and more particularly relates to a container operable with a centrifuge to separate and concentrate various biological components.

BACKGROUND

Various fluids, such as whole blood or various other biological fluids may be separated into their constituent parts, also referred to as fractions or phases. For example, whole blood samples may include a plurality of constituents that may be separated by density in a device such as a centrifuge. The whole blood sample may be placed in a test tube, or other similar device, which is then spun in a centrifuge. In the centrifuge the whole blood is separated into different fractions depending upon the density of that fraction. The centrifugal force separates the blood or other sample into different fractions. In addition, various elements may be added to the test tube to create more than two fractions. In particular, commonly used gels may be used to divide the whole blood into a plurality of different fractions which may include fractions such as platelets, red blood cells, and plasma. Various other biological fluids may be separated as well. For example, nucleated cells may be separated and extracted from bone marrow or adipose tissue sample.

Many of these systems, however, do not provide a simple or efficient method to extract any more than one fraction and especially a fraction other than the top fraction. The top fraction of whole blood is plasma, or other blood constituents suspended in plasma. Thus, to extract other fractions the plasma fraction must either be removed and spun again to obtain the constituents suspended in this plasma. It is difficult to pierce the top fraction without co-mingling the sample. Accordingly, obtaining the other fractions is difficult with commonly known systems.

Other systems have attempted to alleviate this problem by providing a float or other device that is disposed within the sample at the interfaces of the different fractions during the centrifuge process. Nevertheless, these systems still do not allow a simple way to remove the different fractions without remixing the sample fractions. In addition, many of the systems do not allow an easy and reproducible method to remove the desired sample fraction.

Therefore, it is desired to provide a device to allow for the easy and reproducible removal of a particular fraction which does not happen to be the top fraction of a sample. It is desired to remove the required sample without mixing the different fractions during the extraction process. In addition, it is desired to provide a device which allows for a consistent extraction which includes known volumes or concentration of the fraction elements. Moreover, it is desired to separate and concentrate a selected fraction with one centrifugation step.

SUMMARY

An apparatus that separates and concentrates a selected fraction or component of a fluid, such as a biological fluid. For example, a buffy coat or platelet fraction or component of a whole blood sample or an undifferentiated cell component of bone marrow or adipose tissue sample. The apparatus, when used with a centrifuge, is generally able to create at least two fractions. It also provides for a new method of extracting the buffy coat fraction or component or middle fraction from a sample.

The apparatus includes a container to be placed in a centrifuge after being filled with a sample. A buoy or fraction separator, having a selected density that may be less than one fraction but greater than a second fraction, is disposed in the container. In addition, a second buoy may be placed in the container with the first. During the centrifuge processing, the buoy is forced away from a bottom of the container as the denser fraction collects at the bottom of the container. The buoy is generally able to physically separate the denser fraction from another fraction of the sample.

In addition to providing a first buoy and/or a second buoy, a buoy system may be provided. Generally, the buoy system may separate the sample into at least three fractions. The fractions may be separated or extracted from the container without substantially comingling the various fractions. Generally, a first buoy and a second buoy operate together to separate the sample into the various fractions and a syringe or tube may then be interconnected with a portion of the buoy system to extract the selected fractions. For example, a first buoy may be generally density tuned to a red blood cell fraction of a whole blood sample, and a second buoy tuned to a density less than the density of the plasma fraction.

According to various embodiments a method of forming an enriched scaffold for application relative to an anatomy is taught. The method may include obtaining a volume of a first whole material and obtaining a volume of a second whole material. A first fraction of the first whole material and a second fraction of the second whole material may be formed. At least one of the first fraction or the second fraction may be applied to the scaffold.

According to various embodiments a method of withdrawing a material directly from a patient and collecting a selected fraction of the material in a container is taught. The method may include forming an access to port to the patient. A pressure differential in a collection container may be formed relative to the patient. A connection may be made between the patient and the collection container via the port. The collection container may be filled with the material and separating the material to form the selected fraction.

Further areas of applicability of the present invention will become apparent from the detailed description provided hereinafter. It should be understood that the detailed description and specific examples, while indicating various embodiment of the invention, are intended for purposes of illustration only and are not intended to limit the scope of the invention.



## BRIEF DESCRIPTION OF THE DRAWINGS

The present invention will become more fully understood from the detailed description and the accompanying drawings, wherein:

FIG. 1 is a plan view of a separator including a depth gage affixed to a plunger in a tube according to a first embodiment of the present invention;

FIG. 2 is a cross-section view taken along line 2-2 of FIG. 1;

FIG. 3 is an exploded of the separator apparatus;

FIG. 4 is a kit including the separator according to an embodiment of the present invention;

FIG. 5A is a plan view of the separator being filled;

FIG. 5B is a plan view of a blood sample in the separator after the centrifuge process;

FIG. 5C is a plan view of the plunger plunged into the tube with the depth gage to further separate the blood sample;

FIG. 5D is a plan view of the buffy coat and the plasma fractions being extracted from the separator;

FIG. 6A is a side plan view of a buoy system according to various embodiments;

FIG. 6B is a cross-sectional view of the buoy system of FIG. 6a;

FIG. 7A is a plan view of a separator according to various embodiments being filled;

FIG. 7B is a plan view of a separator, according to various embodiments, after a centrifugation process;

FIG. 7C is a plan view of a separator system being used to extract a selected fraction after the centrifugation process;

FIG. 7D is a plan view of a second fraction being extracted from the separator according to various embodiments;

FIG. 8 is a schematic view of an assisted blood withdrawal device;

FIG. 9 is a block diagram of a method for implanting selected fractions of a fluid;

FIGS. 10A-10C is a plan view of a separator system in operation;

FIG. 11 is an environmental view of a sprayer system with a two-part mixture being expressed onto a portion of an anatomy;

FIG. 12 is a partial cross-section view of a bouy system according to various embodiments;

FIG. 13 is a detail partial cross-section view of a bouy system according to various embodiments; and

FIG. 14A-14C is a plan view of a separator system in operation.

## DETAILED DESCRIPTION OF VARIOUS EMBODIMENTS

The following description of various embodiments is merely exemplary in nature and is in no way intended to limit the invention, its application, or uses. Although the following description exemplary refers to a blood separation, it will be understood that the present invention may be used to separate and concentrate any appropriate material. It will be further understood that many multi-component or multi-fraction fluids may be separated. The components or fractions are generally inter-mingled in the whole sample but may be separated with a centrifuge device that causes increased local gravity or gravitational forces.

With reference to FIGS. 1-3, according to various embodiments a separator 10, also referred to as a concentrator, is illustrated according to a first embodiment of the present invention. The separator 10 generally includes a tube or container 12 that is adapted to hold a fluid sample, such as an

anti-coagulated whole blood sample, for further processing. It will be understood that the tube may hold other solutions including constituents of more than one density, such as bone marrow or a mixture of whole blood and bone marrow. The tube 12 includes a top or open end 12a, which is closeable, and a bottom or closed end 12b. The bottom 12b may also be selectively closeable.

Disposed within the tube 12 is a first piston or buoy 14 that is able to move along a central axis A of the tube 12. The buoy 14 is generally nearer the bottom end 12b of the tube 12 rather than the open end 12a. Also disposed within the tube 12 is a second piston or plunger 16. The plunger 16 is also able to move within the tube 12 generally between a position closer to the open end 12a to a position closer to the closed end 12b of the tube 12. A cap 18 substantially mates with the open end 12a of the tube 12 to close the tube 12 save for ports formed in the cap 18. Extending from the cap 18 is a plasma valve or port 20 that communicates with an area, described further herein, within the tube 12 defined between the plunger 16 and the cap 18. It will be understood that the plasma port 20 is merely exemplary in nature and simply allows for removal of a selected fraction of a sample, such as plasma from whole blood.

The cap 18 also includes a depth gage port 19. Extending from the plunger 16 and through the depth gage port 19 is a first plunger port 22. A depth guide or gage 24 includes a female connector 26 adapted to connect with the first plunger port 22. The depth gage 24 also includes a depth gage housing or cannula 28. The depth gage housing 28 defines a depth gage bore 30. Incorporated in the housing 28 and extending distal from the end mating with the plunger is a neck 32. The neck 32 includes external neck threads 34. The external neck threads 34 are adapted to engage appropriate internal threads of a mating member.

The mating member may include a compression nut 36 that mates with the external neck threads 34 to lock a depth gage rod 38 in a predetermined position. A split bushing 39 is also provided to substantially seal the depth gage housing 28 when the depth gage rod 38 is locked in place. The depth gage rod 38 extends through the depth gage housing 28 and terminates at a rod handle 40. The rod handle 40 may be a form easily manipulated by a human operator. The rod 38 extends coaxially with axis A of the tube 12. The depth gage rod 38 extends through the plunger 16 a predetermined distance and may be locked at that distance with the compression nut 36.

Although the tube 12 is described here as a cylinder, it will be understood that other shapes may be used, such as polygons. The internal portions, such as the cap 18, buoy 14, and plunger 16, would also include this alternate shape. Preferably the tube 12 is formed of a thermal plastic material which is flexible under the forces required to separate blood. The tube 12 may be made of a material that includes the properties of both lipid and alcohol resistance. These properties help increase the separation speed and decrease the amount of material which may cling to the tube wall 42. For example, CYROLITE® MED2 multipolymer material including acrylic produced by Cyro Industries of Rockaway, N.J. may be used to produce the tube 12.

The tube 12 has a tube wall 42 with a thickness of between about 0.01 millimeters and about 30.0 millimeters, although the tube wall 42 may be any appropriate thickness. The thickness of the tube wall 42 allows the tube wall 42 to flex during the centrifuge process yet be rigid enough for further processing of a blood sample disposed in the tube 12. The tube 12 is closed at the bottom end 12b with a tube bottom 44 formed of the same material as the tube wall 42 and is formed integrally therewith. Generally the tube bottom 44 has a thickness

which is substantially rigid under the forces required to separate the sample such that it does not flex.

The buoy 14 includes an upper or collection face 46 that defines an inverse cone or concave surface. Generally the cone has an angle of between about 0.5° to about 45°, and may be about 0.5° to about 90° from a vertical axis, wherein the apex of the cone is within the buoy 14. The collection face 46 forms a depression in the buoy 14 which collects and concentrates material during the separation process. Additionally, the buoy 14 has a bottom face 48 that defines an inverse cone, dome, or covered surface. The buoy bottom face 48 includes an apex 50 that engages the tube bottom 44 before a buoy edge 52 engages the tube bottom 44. The buoy 14 includes a material that is a substantially rigid such that the buoy edges 52 never meet the tube bottom 44. Therefore, there is a gap or free space 54 formed between the buoy edge 52 and the tube bottom 44 along the perimeter of the buoy 14.

The separator 10 is generally provided to separate a multi-component fluid that generally includes various components or constituents of varying densities that are co-mingled or mixed together. The separator 10 includes the buoy 14 that is of a selected density depending upon a selected constituent of the multi-constituent liquid. Although the buoy 14 may be tuned or of any selected density, the following example relates to separation of whole blood to various components. Therefore, the buoy 14 will be discussed to include a selected density relative to whole blood separation. It will be understood, however, that the buoy 14 may be of any appropriate density depending upon the multi-component fluid being separated.

The buoy 14 may be formed of any appropriate material that may have a selected density. For example, when the separator 10 is to separate blood, the buoy 14 generally has a density which is greater than that of red blood cells in a whole blood sample, but less than the plasma or non-red blood cell fraction of a whole blood sample. For blood, the density of the buoy 14 is generally between about 1.02 g/cc and about 1.09 g/cc.

To achieve the selected density, the buoy 14 may be formed as a composite or multi-piece construction, including a plurality of materials. Particularly, a first or outside portion 56 defines the collection face or surface 46 and the buoy edge 52 and is formed of the same material as the tube 12. The outside portion 56 defines a cup or void into which a plug or insert 58 is placed. The insert 58 has a mass such that the density of the entire buoy 14 is within the selected range, for example the range described above. Generally, a high density polyethylene may be used, but the material and size of the insert 58 may be altered to produce the desired density of the buoy 14. Alternatively, the buoy 14 may be formed of a single suitable material that has a density in the selected range. Nevertheless, the buoy 14 formed unitarily or of a single material would still include the other portions described in conjunction with the buoy 14.

The outside portion 56 of the buoy 14 also defines the outside circumference of the buoy 14. The outside circumference of the buoy 14 is very close to the internal circumference of the tube 12. Due to the operation of the buoy 14, however, described further herein, there is a slight gap between the outside of the buoy 14 and the inside of the tube 12. Generally, this gap is between about 1 and about 10 thousandths of an inch around the entire circumference of the buoy 14. Generally, it is desired that the distance between the outside circumference of the buoy 14 and the inside circumference of the tube 12 is great enough to allow a selected material or component to pass. For example, in whole blood the distance is

selected so that red blood cells may pass through the gap without being lysed, damaged, or activated.

The plunger 16 includes a plunger front or collection face 60 and a plunger wall 62 that extends from the plunger front face 60. The plunger wall 62 extends relatively perpendicular to the plunger front face 60 and substantially parallel to the tube wall 42. Extending from the center of the plunger 16 is a sample collection projection 64. Extending from the top of the collection projection 64 is the first plunger port 22. The sample collection projection 64 includes a plunger sample collection bore 68 defined therethrough. The plunger sample collection bore 68 terminates at a sample collection aperture 70 that is substantially in the center of the plunger front face 60. The plunger front face 60 also defines an inverse cone where the sample collection aperture 70 is the apex of the cone. The plunger front face 60 defines a cone with an angle substantially similar or complementary to the collection face 46 of the buoy 14. In this way, the plunger front face 60 may mate substantially completely with the collection face 46 for reasons described more fully herein.

The plunger 16 also includes a back face 72. Extending from the plunger front face 60 to the back face 72 is a bore 74. A check valve 76 is operably connected to the bore 74. The check valve 76 allows a liquid to move from the plunger front face 60 to the back face 72 while not allowing the liquid to move from the back face 72 to the plunger front face 60. Therefore, the check valve 76 is substantially a one-way valve which allows a material to move in only one direction. The check valve 76 may also operate automatically allowing flow in only one predetermined direction. Alternatively, the check valve 76 may be operated manually and include a portion extending from the check valve 76 requiring manipulation to stop or start a flow through the check valve 76.

The plunger 16 may be made out of any appropriate material which does not interfere with the separation of the fractions of the fluid, such as whole blood. The plunger 16, however, is made of a material that is flexible or at least partially deformable. A flexible material allows the plunger 16 to have an external circumference defined by the plunger walls 62 that is substantially equal to the internal circumference of the tube 12. Because of the deformability of the plunger 16, however, the plunger 16 is still able to move within the tube 12. The plunger 16 is able to move through the tube 12 and also substantially wipe the interior of the tube wall 42. This creates, generally, a moveable seal within the tube 12. Thus, substantially no material escapes the action of the separator 10 when the plunger 16 is plunged into the tube 12. This also helps concentrate the portion of the sample desired to be collected, described more fully herein.

The cap 18 provides a structure to substantially close the tube 12. The cap 18 particularly includes a plate 78 that has an external circumference substantially equal to the external circumference of the tube 12. Extending from the plate 78 and into the tube 12 is a flange 80. The external circumference of the flange 80 is substantially equal to the internal circumference of the tube 12. In this way, the cap 18 substantially closes the tube 12. It will be understood the cap 18 may be in any form so long as the cap 18 substantially closes and/or seals the tube 12 when installed.

Formed through the center of the plate 78 is the depth gage port 19. The depth gage port 19 is also adapted to receive the sample collection projection 64. The first plunger port 22 extends above the plate 78 through the depth gage port 19. The circumference of the depth gage port 19 is substantially equal to the external circumference of the sample collection projection 64 such that a liquid seal is formed. The plate 78 defines a sample face 84 that includes an interior side of the

cap **18**. The area between the sample face **84** of the cap **18** and the back face **72** of the plunger **16** define a plasma collection area **86**. Although the plasma collection area **86** is exemplary called the plasma collection area, it will be understood that the plasma collection area **86** may also collect any appropriate fraction of the sample that is positioned within a separator **10**. The plasma collection area **86** is merely an exemplary name and an example of what material may be collected in the area of the separator **10**. As discussed herein, the separator **10** may be used to separate whole blood into various fractions, therefore the plasma collection area **86** is used to collect plasma. The plasma collection area **86** also allows a space for the check valve **76** to be installed.

A second bore **88** is formed in the plate **78**. Extending through the second bore **88** is the plasma collection valve **20**. In liquid communication with the plasma collection valve **20** is a plasma collection tube **92**. The plasma collection tube **92** has a length such that the plasma collection tube **92** is able to extend from the plasma collection valve **20** to substantially the tube bottom **44**. The plasma collection tube **92**, however, is flexible enough such that it may be folded or compressed to fit within the plasma collection area **86** when the plunger is substantially near the top **12a** of the tube **12**. The plasma collection tube **92** may also be connected to a hose barb **93** that includes a plasma collection bore **93a**. The plasma collection bore **93a** is substantially level with the plunger back face **72**. Alternatively, the plasma collection bore **93a** may be positioned below the plunger back face **72** but in fluid communication with the plasma collection tube **92**.

The outboard side of the plasma collection valve **20** may include external threads **94** to mate with internal threads of a plasma valve cap **96**. Therefore, the plasma collection valve **20** may be selectively opened and closed via the plasma valve cap **96**. It will be understood, however, that other appropriate means may be used to open and close the plasma collection valve **20** such as a clip or a plug. It will be understood that the plasma collection valve **20**, plasma collection tube **92**, plasma collection bore **88** may be used to collect any appropriate material or fraction from the separator **10**.

Also formed in the plate **78** is a vent bore **98**. The vent bore **98** allows air to flow into the collection area **86** as the plunger **16** is being plunged into the tube **12**. The vent bore **98** may include a filter **100** such that liquid cannot escape from the tube **12**. The filter **100** allows air to enter or escape from the collection area **86** while maintaining the liquid seal of the tube **12** produced by the cap **18**.

Selectively attachable to the first plunger port **22** is the depth gage **24**. The female connector **26** interconnects the depth gage housing **28** to the first plunger port **22**. Internal threads in the female connector **26** mate with an external thread **102** formed on the first plunger port **22**. It will be understood, however, that other engagement mechanisms between the depth gage **24** and the plunger **16** may be used. For example, a snap connection rather than a threaded connection between the two may be used.

The depth gage housing **28** is formed to be substantially rigid. Suitable materials, when sized properly, include polycarbonate and CYROLITE® MED2 multipolymer material including acrylic. The material preferably is both rigid and does not substantially react with the sample. It is rigid enough to provide a mechanism to plunge the plunger **16** into the tube **12**. In addition the external circumference of the depth gage housing **28** is substantially equal to the circumference of the depth gage port **19** in the plate **78**. Therefore, as the plunger **16** is being plunged into the tube **12** with the depth gage **24**, no liquid material is allowed to escape around the depth gage housing **28** and through depth gage port **19**.

Formed within the depth gage housing **28** is the bore **30** which receives the depth gage rod **38**. The depth gage rod **38** extends through the sample collection bore **68** of the sample collection projection **64** and protrudes through the sample collection aperture **70** a predetermined length. The depth gage rod **38** extends through the sample collection aperture **70** a length such that when an end **104** of the depth gage rod **38** meets the buoy **14**, the volume defined by the collection face **46** and the plunger front face **60** is between about 5 percent and about 30 percent of the total volume of the sample that the tube **12** holds. The projection of the depth gage rod **38** allows for an easily reproducible collection amount and concentration over several trials.

The compression nut **36** locks the depth gage rod **38** in the predetermined position. Nevertheless, once the plunger **16** has been plunged to the desired depth in the tube **12**, the compression nut **36** may be loosened so that the depth gage rod **38** may be removed from the plunger **16** and the depth gage housing **28** without moving the plunger **16**. A syringe or other appropriate device may then be affixed to the external neck threads **34** of the depth gage **24** to extract the fraction or phase that is between the plunger front face **60** and the collection face **46**. As described further herein, the fraction or phase that is left between the plunger front face **60** and the collection face **46** may be the buffy coat of a whole blood sample. Nevertheless, it will be understood that the fraction between the plunger front face **60** and the collection face **46** may be any appropriate fraction of the sample that is disposed in the separator **10**.

The separator **10** may be provided alone or in a kit **200**, as illustrated in FIG. **4**. The kit **200** may be placed in a tray **202** which is covered to provide a clean or sterile environment for the contents of the kit **200**. The kit **200** may include at least a first separator **10** and a second separator **10'**. A first depth gage **24** and a second depth gage **24'** are also provided, one for each separator **10**, **10'**. The kit **200** also generally includes a first syringe **204**, including a needle, to draw a biological sample, such as blood from a patient. The first syringe **204** may also be used to place the sample in the first separator **10**. After centrifuging the sample a second device or syringe **210** may be used to extract a first fraction of the sample. While a third device or syringe **212** may be used to extract a second fraction of the sample. Also a tourniquet **214** and other medical supplies, such as gauze **216** and tape **218**, may be provided to assist the practitioner. It will be understood the elements of the kit **200** are merely exemplary and other appropriate items or elements may be included.

With reference to FIGS. **5A-5D** a method using the blood separator **10** is illustrated. The following example relates specifically to the taking and separation of a sample of whole blood from a patient. Nevertheless, it will be understood that another appropriate biological material may be separated and concentrated using the separator **10**. For example, bone marrow may be separated and concentrated using the separator **10**. The various fractions of the bone marrow are similar to the fractions of whole blood. Generally, the bone marrow includes a fraction that includes substantially dense material and a second phase that is less dense and has other components suspended therein, such as nucleated cells. The bone marrow sample may be positioned in the separator **10**, similarly to the whole blood as described herein, and separated in a substantially similar manner as the whole blood. The separator **10** can then be used to remove nucleated cells from the bone marrow sample whereas the separator **10**, as described herein, is used to remove the buffy coat from the whole blood which includes platelets and other appropriate materials.

A mixture of whole blood and bone marrow may be positioned in the separator **10** for separation and concentration. Similar methods and steps will be used to separate the mixture of whole blood and bone marrow with a main difference being the material that is separated. It will also be understood that various centrifuge times or forces may be altered depending upon the exact material that is being separated with the separator **10**. It will also be understood that the separation of whole blood, bone marrow, or a mixture of whole blood and bone marrow are merely exemplary of the materials that may be separated using the separator **10**.

With reference to FIGS. 5A-5D and to a whole blood sample, a sample of whole blood taken from a patient is placed in the tube **12** with an anticoagulant using the first syringe **204** or other appropriate delivery method. In particular, the first syringe **204** may be connected to the first plunger port **22**. After which the blood sample is provided to the tube **12** via the sample collection bore **68** and sample collection aperture **70**. A cap **220** is then placed over the first plunger port **22** to substantially seal the tube **12**.

After the whole blood sample is delivered to the tube **12**, the separator **10** is placed in a centrifuge. The second separator **10'**, substantially identical to the first, is placed opposite the first separator **10** including the sample in a centrifuge. The second separator **10'** may also include a second sample or may include a blank, such as water, so that the centrifuge is balanced. The second separator **10'** balances the centrifuge, both by weight and dynamics.

The separator **10** is then spun in the centrifuge in a range between about 1,000 and about 8,000 RPMs. This produces a force between about 65 and about 4500 times greater than the force of normal gravity, as generally calculated in the art, on the separator **10** and the blood sample placed in the separator **10**. At this force, the more dense material in a whole blood sample is forced towards the bottom **12b** of the tube **12**. The dense material, such as red blood cells or a red blood cell fraction **222**, collects on the tube bottom **44**. Because the buoy **14** has a density that is less than the red blood cell fraction **222**, it is forced in a direction toward the top **12a** of the tube **12** in the centrifuge. Nevertheless, because the buoy **14** is denser than a plasma fraction **224**, the buoy **14** does not reach the top **12a** of the tube **12**.

The forces also affect the tube wall **42**. The forces compress the tube **12** linearly along axis A thereby bowing or flexing the tube wall **42**. As the tube wall **42** compresses it increases the diameter of the tube **12** making it easier for the buoy **14** to move in the direction of the top **12a** of the tube **12**. In addition, the bottom face **48**, defining an inverse cone, helps the initial movement of the buoy **14**. Because the buoy **14** is not substantially flat along its bottom, it does not form a vacuum interaction with the tube bottom **44**. Therefore, the initial movement of the buoy **14** away from the tube bottom **44** is quicker than if the bottom of the buoy **14** was flat.

During the centrifuge process the red blood cells of the red blood cell fraction **222** force the buoy **14** in the direction of the top **12a** of the tube **12** because the buoy **14** is less dense than the red blood cell fraction **222**. Although the whole blood sample, including the red blood cells is loaded above the buoy **14**, the red blood cells are able to move between the buoy **14** and the tube wall **42** because the circumference of the buoy **14** is less than the internal circumference of the tube **12**. During the centrifuge process the buoy **14** stops at an interface of a plasma fraction **224** and the red blood cell fraction **222** because of the selected or tuned density of the buoy **14**.

With particular reference to FIG. 5B, the centrifuge process has been completed and the buoy **14** has moved to the interface of the red blood cell fraction **222** and plasma frac-

tion **224**. After the centrifuge has slowed or stopped, and before or after the tube **12** has been removed from the centrifuge, the tube wall **42** decompresses which helps support the buoy **14** at the interface position. It is also understood that applying an external pressure to the tube **12** via fingers or another apparatus may help stabilize the buoy **14** during the plunging procedure described herein.

On or near collection face **46** is a third fraction **226** including a small, yet concentrated, amount of red blood cells, white blood cells, platelets, and a substantial portion of a buffy coat of the blood sample. Although the plasma is also present near the collection face **46** at this point the solid portions of the buffy coat are more compressed against the collection face **46**. The position of the buoy **14** also helps in this matter. Because the buoy **14** is a single body it defines the interface of the plasma fraction **224** and the red blood cell fraction **222**. Also the density of the buoy **14** assures that it has not passed into the plasma fraction **224**. Therefore, the fractions remain separated after the centrifuge process. In addition because the buoy **14** is tuned to the density of the red blood cell fraction **222**, it is not affected by variations in the density of the plasma fraction **224** and the buoy's **14** position is always at the interface of the red blood cell fraction **222** and the plasma fraction **224**.

With particular reference to FIG. 5C, the depth gage **24** is affixed to the first plunger port **22** of the sample collection projection **64**. After connecting the depth gage **24** to the first plunger port **22**, the plunger **16** is plunged into the tube **12** by pushing on the depth gage **24**. As this is performed the plasma fraction **224**, formed and separated above the buoy **14**, is able to flow through the check valve **76** into the plasma collection area **86**. This displacement of the plasma fraction **224** allows the plunger **16** to be plunged into the tube **12** containing the blood sample.

The plunger **16** is plunged into the tube **12** until the point where the end **104** of the depth gage rod **38** reaches the buoy **14**. The volume left in the collection face **46** is the third fraction **226** and is determined by the depth gage **24**. It may be adjusted by selectively determining the amount that the depth gage rod **38** extends below the plunger front face **60**. By adjusting the depth gage **24**, the concentration of the third fraction **226** can be adjusted depending upon the desires of the operator.

The plasma fraction **224** is held in the plasma collection area **86** for later withdrawal. Therefore, the use of the plunger **16** and the buoy **14** creates three distinct fractions that may be removed from the tube **12** after only one spin procedure. The fractions include the red blood cell fraction **222**, held between the buoy **14** and the tube bottom **44**. The third or buffy coat fraction **226** is held between the plunger **16** and the buoy **14**. Finally, the plasma fraction **224** is collected in the plasma collection area **86**.

The third fraction **226** may be extracted from the tube **12** first, without commingling the other fractions, through the sample collection bore **68**. With particular reference to FIG. 5D, the depth gage rod **38** may be removed from the depth gage housing **28**. This creates a sample collection cannula which includes the depth gage bore **30**, the sample collection bore **68**, and the sample collection aperture **70**. After the depth gage rod **38** has been removed, the second syringe **210** may be affixed to the depth gage housing **28** via the external neck threads **34**. The second syringe **210** may be substantially similar to the first syringe **204**.

Before attempting to withdraw the third fraction **226** the separator **10** may be agitated to re-suspend of the platelets and concentrated red blood cells in a portion of the plasma remaining in the collection face **46**. This allows for easier and

more complete removal of the third fraction 226 because it is suspended rather than compressed against the collection face 46. A vacuum is then created in the second syringe 210 by pulling back the plunger to draw the third fraction 226 into the second syringe 210.

As the third fraction 226 is drawn into the second syringe 210 the plunger 16 moves towards the buoy 14. This action is allowed because of the vent bore 98 formed in the cap 18. Atmospheric air is transferred to the plasma collection area 86 through the vent bore 98 to allow the third fraction 226 to be removed. This also allows the movement of the plunger 16 towards the buoy 14. This action also allows the plunger 16 to “wipe” the collection face 46. As the plunger front face 60 mates with the collection area 46 the third fraction 226 is pushed into the sample collection aperture 70. This ensures that substantially the entire third fraction 226 collected in the collection area 46 is removed into the second syringe 210. It can also increase the repeatability of the collection volumes. In addition, because the second syringe 210 does not protrude out the sample collection aperture 70, it does not interfere with the collection of the third fraction 226. Once the plunger front face 60 has mated with the collection face 46 there is substantially no volume between the plunger 16 and the buoy 14.

Once the third fraction 226 is extracted the second syringe 210 is removed from the first plunger port 22. Also the extraction of the third fraction 226 leaves the plasma fraction 224 and the red blood cell fractions 222 separated in the tube 12. At this point a third syringe 212 may be affixed to the plasma collection valve 20. The third syringe 212 is connected to the external threads 94 of the plasma collection valve 20 to ensure a liquid tight connection. It will be understood, however, that another connection mechanism such as a snap or compression engagement may be used to connect the third syringe 212 to the plasma collection valve 20.

A vacuum is then created in the third syringe 212 to draw the plasma fraction 224 from the plasma collection area 86 through the plasma collection tube 92. As discussed above, the plasma collection tube 92 is connected to the hose barb 93. Therefore, the plasma flows through the plasma collection bore 93a through the hose barb 93, and then through the plasma collection tube 92. It will be understood that the plasma collection tube 92 may alternatively simply rest on the plunger back face 72 to collect the plasma fraction 224. In this way the plasma fraction 224 may be removed from the blood separator 10 without commingling it with the red blood cell fraction 222. After the plasma fraction 224 is removed, the separator 10 may be dismantled to remove the red blood cell fraction 222. Alternatively, the separator 10 may be discarded in an appropriate manner while retaining the red blood cell fraction 222.

The separator 10 allows for the collection of three of a whole blood sample’s fractions with only one centrifugation spin. The interaction of the buoy 14 and the plunger 16 allows a collection of at least 40% of the available buffy coat in the whole blood sample after a centrifuge processing time of about 5 minutes to about 15 minutes. The complementary geometry of the plunger front face 60 and the collection face 46 help increase the collection efficiency. Although only the cone geometry is discussed herein, it will be understood that various other geometries may be used with similar results.

The plunger front face 60 being flexible also helps ensure a complete mating with the collection face 46. This, in turn, helps ensure that substantially the entire volume between the two is evacuated. The process first begins with the suction withdrawal of the third fraction 226 via the second syringe 210, but is completed with a fluid force action of the third

fraction 226 as the plunger front face 60 mates with the collection face 46. As the plunger front-face 60 mates with the collection face 46 the fluid force assists in removal of the selected fraction.

The plunger 16 also substantially wipes the tube wall 42. Because the plunger 16 is formed of a flexible material it forms a seal with the tube wall 42 which is movable. Therefore, substantially no liquid is able to move between the plunger wall 62 and the tube wall 42. Material is substantially only able to go past the plunger front face 60 via the check valve 76.

The complementary geometry also helps decrease the collection time of the third fraction 226. Therefore, entire time to prepare and remove the third fraction 226 is generally about 5 to about 40 minutes. This efficiency is also assisted by the fact that the separator 10 allows for the removal of the third fraction 226 without first removing the plasma fraction 224, which includes the buffy coat, and respinning the plasma fraction 224. Rather one spin in the separator 10 with the whole blood sample allows for the separation of the buffy coat for easy extraction through the plunger 16.

As discussed above, the separator 10 may be used to separate any appropriate multi-component material. For example, a bone marrow sample may be placed in the separator 10 to be centrifuged and separated using the separator 10. The bone marrow sample may include several fractions or components that are similar to whole blood fractions or may differ therefrom. Therefore, the buoy 14 may be altered to include a selected density that is dependent upon a density of a selected fraction of the bone marrow. The bone marrow may include a selected fraction that has a different density than another fraction and the buoy 14 may be designed to move to an interface between the two fractions to allow for a physical separation thereof. Similar to the whole blood fraction, the plunger 16 may then be moved to near a collection face 46 of the buoy 14. The fraction that is then defined by the collection face 46 and the plunger 16 may be withdrawn, as described for the removal of the buffy coat from the whole blood sample. For example, the middle fraction or third fraction in the bone marrow sample may include a fraction of undifferentiated or stem cells.

It will also be understood that mixtures of various fluids may be separated in the separator 10. For example, a mixture of whole blood and bone marrow may be positioned in the separator 10 at a single time. The buoy 14 may be tuned to move to an interface that will allow for easy removal of both the buffy coat, from the whole blood sample, and the undifferentiated cells, from the bone marrow sample. Nevertheless, it will be understood that the separator 10 may be used within any appropriate biological material or other material having multiple fractions or components therein. Simply, the buoy 14 may be tuned to the appropriate density and the plunger 16 may be used to cooperate with the buoy 14 to remove a selected fraction.

With reference to FIGS. 6A and 6B, a buoy system 300 is illustrated. The buoy system 300 generally includes a first buoy or fraction separator member 302 and a second buoy member or fraction separator 304. The first buoy 302 and the second buoy 304 may be operably interconnected with a buoy system cylinder or member 306. The buoy system 300 may be placed in a tube, such as the tube 12. The tube 12 may be formed of any appropriate material, such as the CYROLITE® MED2 multipolymer material including acrylic as discussed above. Nevertheless, the buoy system 300 may be designed to fit in the tube 12 or may be formed to fit in any appropriate member that may be disposed within a selected centrifuging device. It will be understood that the following discussion

13

relating to buoy system 300 to be substantially matched to the size of the tube 12 is merely exemplary. As the buoy 14 may be sized to fit in any appropriate tube, the buoy system 300 may also be sized to fit in any appropriate tube. It will be further understood that the tube 12 may be any appropriate shape. The tube 12 need not only be cylindrical but may also be or include conical portions, polygonal portions, or any other appropriate shapes.

The first buoy 302 of the buoy system 300 may be generally similar in geometry to the buoy 14. It will be understood that the first buoy member 302 may be formed in the appropriate manner including shape or size to achieve selected results. Nevertheless, the first buoy member 302 generally includes an exterior diameter that may be slightly smaller than the interior diameter of the tube 12. Therefore, the first buoy member 302 may be able to move within the tube 12 during the centrifugal process. Also, as discussed above, the tube 12 may flex slightly during the centrifuging process, thus allowing the first buoy member 302 to include an exterior diameter substantially equivalent to the interior diameter of the tube 12. As discussed further herein, during the centrifugation process, a portion of the fraction of a sample may pass between the exterior wall of the first buoy member 302 and the tube 12.

The first buoy member 302 may generally include a density that is substantially equivalent to a first or selected fraction of the sample. If the sample to be separated includes whole blood and is desired to separate the red blood cells from the other portions of the sample, the first buoy member 302 may have a selected density that may be about 1.00 grams per cc (g/cc) to about 1.10 g/cc. It will be understood that the density of the first buoy member 302 may be any appropriate density, depending upon the fraction to be separated, and this range of densities is merely exemplary for separating red blood cells from a whole blood sample.

In addition, the first buoy member 302 includes a collection face or area 308 at a proximal or upper portion of the first buoy member 302. The collection face 308 generally defines a concave area of the first buoy member 302 and may have a selected angle of concavity. The buoy assembly 300 defines a central axis D. The collection face 308 defines a surface E that is formed at an angle  $\gamma$  to the central axis D of the buoy system 300. The angle  $\gamma$  may be any appropriate angle and may be about 0.5° to about 90°. The angle  $\gamma$  may, however, be between about 45° and 89.5°. Nevertheless, it will be understood that the angle  $\gamma$  may be any appropriate angle to assist in collection of a selected fraction or portion of the sample by the first buoy member 302.

A bottom or lower surface 310 of the first buoy member 302 may define a bottom face. The bottom face 310 may also be formed at an angle D relative to the central axis D. The bottom surface 310 defines a surface or plane F that may be formed at an angle A relative to the central axis D of the buoy system 300. The angle A may be any appropriate angle and may be about 90° to about 160°. For example, the angle A may be about 15°. Similarly to the buoy bottom face 48, the bottom surface 310 defines an apex 312 that may first engage the bottom 12d of the tube 12, such that most or the majority of the bottom surface 310 does not engage the tube 12. As illustrated further herein, the apex 312 allows for a free space or gap to be formed between the bottom face 310 of the first buoy member 302 and the bottom 12b of the tube 12.

The second buoy member 304 may include an outer diameter substantially equivalent to the outer diameter of the first buoy member 302. Therefore, the second buoy 304 may move with the first buoy 302, particularly if the second buoy 304 is interconnected with the first buoy 302 with the buoy central cylinder 306. Nevertheless, the second buoy member 304

14

may be allowed to move substantially freely within the tube 12 during the centrifuging process.

The second buoy member 304 also includes an upper or superior surface 314 that defines a plane G that is formed at an angle relative to the central axis D of the buoy system 300. The angle  $\epsilon$  of the plane G relative to the central axis D of the buoy system 300 may be any appropriate angle. For example, the angle  $\epsilon$  may be about 90° to about 150°. Generally, the angle  $\epsilon$  may assist in allowing a selected fraction or a portion of the sample to pass over the top surface 314 and past the second buoy member 304 during the centrifuging process.

The second buoy member 304 also define a bottom or inferior surface 316 that also defines a plane H that may be formed at an angle K relative to the central axis D of the buoy system 300. The angle K may be any appropriate angle, such as about 90° to about 150°. Nevertheless, the angle K may be substantially complementary to the angle  $\gamma$  of the collection face 308 of the first buoy member 302. For example, if the angle  $\gamma$  is about 80°, the angle K may be about 100°, such that substantially 180° or a straight line is formed when the first buoy member 302 engages the second buoy member 304. This may be for any appropriate reason, such as extraction of a fraction that may be disposed near the collection face 308 of the first buoy member 302. Nevertheless, the angle K may be any appropriate angle as the angle  $\gamma$ .

The second buoy member 304 may be formed to include any appropriate density. For example, the second buoy member 304 may include a density that is less than the plasma fraction of a whole blood sample. It will be understood that the second buoy member 304 may include any appropriate density and a density that is less than the plasma fraction of a whole blood sample is merely exemplary. Nevertheless, if a whole blood sample is desired to be separated and the plasma sample is to be substantially separated from another fraction, the second buoy member 304 may include a density that is less than the plasma fraction of the whole blood sample. Therefore, the density of the second buoy member 304 may be about 0.01 g/cc to about 1.03 g/cc. As described herein, if the second buoy member 304 includes a density less than the plasma fraction of a whole blood sample and the first buoy member 302 includes a density greater than that of the red blood cells, the buoy system 300 may be substantially positioned near an interface between the red blood cell fraction and the plasma fraction of a whole blood sample. Therefore, as discussed above, and further described herein, the platelet or buffy coat fraction of the whole blood sample may be substantially collected near or in the collection face 308 of the buoy system 300.

The buoy post 306 may operably interconnect the first buoy member 302 and the second buoy member 304. The buoy post 306 may be any appropriate connection member. The buoy post need not be a single cylindrical portion. For example the buoy post 306 may include one or more members interconnecting the first buoy member 302 and the second buoy member 304, such as around a perimeter thereof. In addition, the buoy post 306 may include any appropriate shape or geometry.

The buoy system post 306 may be rigidly affixed to the first buoy member 302 and the second buoy member 304, such that the first buoy member 302 may not move relative to the second buoy member 304 and vice versa. Alternatively, the buoy post 306 may be slidably connected to either or both the first buoy member 302 and the second buoy member 304. According to various embodiments, the buoy post 306 is generally fixedly connected to the first buoy member 302 and slidably interconnected to the second buoy member 304. The buoy post 306 may include a catch portion or lip 320 that is

able to engage a portion of the second buoy member **304**, such that a range of travel of the second buoy member **304**, relative to the first buoy member **302** is limited. Nevertheless, the range of travel of the second buoy member **304** towards the first buoy member **302** may be substantially unlimited until the second buoy member **304** engages the first buoy member **302**.

The buoy post **306** may also define a central cannula or bore **322**. The post bore **322** may include a connection portion **324** substantially defined near an upper or a proximal end of the buoy post **306**. This may allow for interconnection of various components with the buoy post **306**, such that various components may be moved through the bore **322** from an exterior location. The buoy post **306** may also define a port or cannula **326** that connects the post cannula **322** with the collection face **308**. Therefore, a substance may travel through the post cannula **322** and through the port **326**. Various substances may then be provided to or removed from the collection face **308** of the first buoy member **302**.

The buoy system **300** may be used to separate a selected multi component sample, such as a whole blood sample. With continuing reference to FIGS. **6A** and **6B**, and reference to FIGS. **7A-7D**, a method of using the buoy system **300**, according to various embodiments, is illustrated and described. With reference to FIGS. **7A-7D**, like reference numerals are used to indicate like portions of the tube **12** and the associated mechanisms described in FIGS. **1-3**. Therefore, it will be understood that the buoy system **300** may be used with the tube **12** or any other appropriate tube or container system or apparatus. Nevertheless, for simplicity, the description of a method of use of the buoy system **300** will be described in conjunction with the tube **12**.

The tube **12** may include the cap **18** that further defines a plasma valve or port **20**. Extending through the cap **18** and interconnecting with a first flexible tube or member **92**, the plasma port **20** may be used to extract a selected fraction of the sample that is positioned above the second buoy member **304**. As illustrated above, the first tube **92** may also be interconnected with a selected portion of the system, such as the top surface **314** of the second buoy member **304**. As illustrated above, a valve may be positioned and is operably interconnected the tube **92** with the upper surface **314** of the second buoy member **304**. Nevertheless, such a valve is not necessary and it may be provided merely for convenience.

Other portions of the blood separator system **20**, particularly those portions of the tube **12** and the cap **18** that have various valves connected therewith may be included in the tube **12** and used with the buoy system **300**. Nevertheless, once the buoy system **300** is interconnected, it may be positioned in the interior of the tube **12** and the syringe **204** used to place a sample into the tube **12**. The sample may be expressed from the syringe **204** into the interior of the tube **12** and the sample may be any appropriate sample, such as a whole blood sample. Nevertheless, it will be understood, such as discussed above, various other samples may be used, such as bone marrow samples, a mixture of bone marrow and whole blood or nonbiological fluids or materials. It will be understood that two buoys **302** and **304** may generally be near one another when the sample is positioned in the tube **12**, but are illustrated apart for clarity of the present discussion.

Also, the sample may be placed in the tube **12** according to various methods. As described above, an anticoagulant or other components may be mixed with the whole blood sample, if a whole blood sample is used, before the whole blood sample is positioned within the tube **12**. The syringe

**204** is connected with the plunger port **22** extending from the cap **18**, although a plunger may not be used in various embodiments.

After the sample is positioned within the tube **12**, as described above, a cap may be positioned over the port **22**, such that the sample is not allowed to escape from the tube **12**. After the sample is placed in the tube **12** and the cap placed on the port **22**, the tube **12** including the sample and the buoy system **300** may be centrifuged.

With reference to FIG. **7B**, after a centrifugation of the tube **12**, including the buoy system **300**, substantially three fractions of the sample may be formed. A first fraction **330** may be positioned between the bottom face **310** and the bottom of the tube **44**. A second fraction may be positioned between the collection face **308** and the bottom surface **316** of the second buoy **304**. In addition, a third fraction may be positioned between the upper surface **314** and the cap **18** of the tube **12**. Generally, the first fraction **330**, the second fraction **332**, and the third fraction **334** are substantially physically separated with the buoy system **300**. During the centrifugation process, the tube **12** may flex slightly to allow for ease of movement of the buoy system **300** through the tube **12** and the sample. Nevertheless, the buoy system **300**, during the centrifugation process, substantially creates the three fractions **330**, **332**, and **334** without the operation of an operator. Therefore, the formation of at least three fractions may be substantially simultaneous and automatic using the buoy system **300**.

The buoy system **300** substantially separates the fractions **330**, **332**, and **334**, such that they may be easily removed from the tube **12**. For example, with reference to FIG. **7C**, a syringe or other instrument **340** may be used to extract the second fraction **332** by interconnecting a cannula or bored tube **342** with the connection portion **324** of the buoy cylinder **306**. By drawing the plunger **344** into the extraction syringe **340**, a vacuum or upward force is produced within the extraction syringe **340**. This force draws the second fraction **332** through the ports **326** of the buoy post **306** and through the buoy cannula **322**. Therefore, the second fraction **332** may be extracted from the tube **12** without substantially comingling the second fraction **332** with either the first fraction **330** or the third fraction **334**. The second fraction **332** is drawn in the direction of arrow **M** through the cannula **322** and into the extraction syringe **340**.

Alternatively, if the post **306** is not provided other portions may be provided to gain access to the second fraction **332**. For example, if a plurality of members are provided around the perimeter of the first buoy **302** and the second buoy **304** a valve portion, such as a puncture-able valve, may be provided in the second buoy **304** to be punctured with an object. In this way an extraction needle may puncture the valve to gain access to the second fraction **332**. Regardless, it will be understood that the buoy system **300** may be able to form a plurality of fractions, such as the three fractions **330**, **332**, and **334** and at least the second fraction **332** may be extracted without substantially comingling the various fractions.

During the extraction of the second fraction **332** through the cannula **322**, the second buoy member **304** may move in the direction of arrow **N** towards the first buoy member **302**. As described above, the collection face **308** of the first buoy member may include an angle  $\gamma$  that is substantially complementary to the bottom face **316** of the second buoy member **304**. Therefore, if the second buoy member **304** is allowed to move along the buoy cylinder **306**, the bottom face **316** of the second buoy member **304** may be able to substantially mate with the collection face **308** of the first buoy member **302**. Alternatively, if the second buoy member **304** is not allowed to move, the second buoy member may be provided with a



17

vent port or valve, such that the extraction of the second fraction 332 from the collection face 308 may not be hindered by the buildup of undesirable forces. Nevertheless, if the second buoy member 304 may move, the interaction of the bottom face 316 of the second buoy member 304 may assist in substantially removing the entire second fraction 332 from the tube 12. As described above, the bottom face 60 of the plunger 16 may also serve a similar purpose when engaging the collection face 46 of the buoy 14.

With reference to FIG. 7D, once the second fraction 332 has been extracted from the tube 12, the second buoy member 304 may substantially mate with a portion of the first buoy member 302. As discussed above, the second buoy member 304 may substantially only mate with the first buoy member 302 if the second buoy member 304 is able to substantially move relative to the first buoy member 302. Therefore, it will be understood that the second buoy member 304 need not necessarily mate with the first buoy member 302 and is merely exemplary of an operation of various embodiments. Nevertheless, once the second fraction 332 has been extracted from the tube 12, the port 20 may be used in conjunction with a selected instrument, such as a plasma extraction syringe 212 to remove the plasma or the third fraction 334 from the tube 12 using the extraction tube 92 interconnected with the port 20.

As described above, the tube 92 allows for extraction of the third fraction 334 from the tube 12 without comingling the third fraction 334 with the remaining first fraction 330 in the tube 12. Therefore, similar to the separator and extraction system 10, three fractions may be substantially formed within the tube 12 with the buoy system 300 and may be extracted without substantially comingling the various fractions. Once the third fraction 334 is extracted from the tube 12, the buoy system 300 may be removed from the tube 12, such that the first fraction 330 may be removed from the tube 12. Alternatively, the first fraction 330 may be discarded with the tube 12 and the buoy system 300 as a disposable system. Alternatively, the system may be substantially reusable, such that it can be sterilized and may be sterilized for various uses.

The description of the method of use of the buoy system 300 is exemplary of a method of using a system according to various other embodiments. It will be understood, however, that various specifics may be used from various embodiments to allow for the extraction of selected fractions. For example, the centrifugation process may be substantially a single step centrifugation process. The buoy system 300, according to various embodiments, may allow for the formation of three fractions during a single centrifugation process. This centrifugation process may occur at any appropriate speed, such as about 1000 rpms to about 8000 rpms. This speed may produce a selected gravity that may be approximately 4500 times greater than the normal force of gravity. Nevertheless, these specifics are not necessary to the operation of the buoy system 300 according to various embodiments. The buoy system 300, according to various embodiments, may be used to extract a plurality of fractions of a sample after only a single centrifuging process and without substantially comingling the various fractions of the sample.

With reference to FIG. 8, the blood collection and separation system that includes the tube 12, according to various embodiments, may be filled with a multi-component fluid or solution, such as blood from a patient, is illustrated. The tube 12 may include any appropriate separation system, such as the separation system 300. Nevertheless, in addition to filling the tube 12 with a fluid from the syringe 204 any appropriate method may be used to fill the tube 12. For example, when a

18

solution, including a plurality of components, is placed into the tube 12 it may be collected directly from a source.

For example, a patient 350 may be provided. The patient 350 may be provided for a selected procedure, such as generally an operative procedure or other procedure that requires an intravenous connection 352, such as a butterfly needle, to be provided in the patient 350. The intravenous connection 352 generally provides a tube 354 extending therefrom. The tube 354 may be used to withdraw fluids from the patient 350 or provide materials to the patient 350, such as medicines or other selected components. Nevertheless, the intravenous connection 352 is generally provided for various procedures and may be used to fill the tube 12.

The tube 354 may interconnect with the plunger port 22 or any appropriate portion of the tube 12. The port 22 may be used to connect with the tube 354 in a similar manner as it would connect with the syringe 204, if the syringe 204 was provided. Nevertheless, it will be understood that the tube 354 may be provided directly to the tube 12 from the patient 350. This may reduce the number of steps required to fill the tube 12 and reduce possible cross-contamination from the patient 350 with the various components. Moreover, making a connection directly with the patient 350 may make the withdrawal and collection of blood from the patient 350 more efficient.

Once the tube 354 is interconnected with the tube 12 the pressure differential between the patient 350, such as the intravenous pressure of the blood, may be used to fill the tube 12 to a selected volume. In addition, a vacuum system 356 may be provided. The vacuum system 356 may include a vacuum inducing portion or member 358, such as a resilient bulb. The vacuum inducing member 358 may be interconnected with the tube 12 through a selected connecting portion 360.

The vacuum connecting portion 360 may interconnect with an orifice 362. The orifice 362 may be interconnected or extend from the cap 18 or provided in any appropriate portion with the tube 12. Nevertheless, a first one way valve 364 may be provided along the connection portion 360 or near the orifice 362. The one way valve 364 provides that a flow of a fluid, such as a gas, may pass in a first direction but not in a second. A second one way valve 366 may also be provided downstream from the first one way valve 364. In this way, a vacuum may be created with the vacuum inducing member 358, such that air is drawn out of the tube 12 and removed through the second one way valve 366 in the direction of arrow V. Due to the first and second one-way valves 364, 366 the air is generally withdrawn from the tube 12 without substantially allowing the air to flow back into the tube 12. Thus, a vacuum can be created within the tube 12 to assist with removing a selected volume of fluid, such as blood, from the patient 350.

Because the tube 12 may be filled substantially directly from the patient 350, the collection of the fluid, such as blood, may be provided substantially efficiently to the tube 12. Although any appropriate mechanism may be used to assist in withdrawing the blood from the patient 350 the vacuum system 356 may be provided including the vacuum inducing member 358. Any appropriate vacuum creating device may be used, such as a mechanical pump or the like. Nevertheless, the tube 12 may be filled for use during a selected procedure.

As discussed above, the tube 12 may be used to separate a selected portion of the blood obtained from the patient 350 substantially intraoperatively. Therefore, the collection or separation of the various components may be substantially autologous and substantially intraoperatively. Moreover, obtaining the fluid directly from the patient 350 may increase



the efficiency of the procedure and the efficiency of the intra-operative or the operative procedure.

With reference to FIG. 9, the separator **10** may be used to separate any appropriate material. The material may be separated for any purpose, such as a surgical procedure. For example, a selected fraction of a bone marrow aspirate or a bone marrow portion may be produced with the separator **10** according to various embodiments. The selected fraction of the bone marrow aspirate may include various components, such as undifferentiated cells. The various undifferentiated cells may be positioned in a selected scaffold or relative to a selected portion of a patient for providing a volume of the undifferentiated cells to the patient. It will be understood that the method described according to FIG. 9 is merely exemplary of various embodiments that may be used to provide a selected fraction of a bone marrow aspirate or other material to a patient or selected position. The selected portion may be placed on the scaffold in any appropriate manner, such as by spraying, dipping, infiltrating, or any appropriate method.

A method of selecting or creating a selected fraction of a bone marrow aspirate in a selected scaffold according to a method **400** is illustrated in FIG. 9. Generally, the method **400** may start in block **402** in obtaining a bone marrow aspirate volume. The bone marrow aspirate (BMA) may be obtained in any selected or generally known manner. For example, a selected region of bone, such as a portion near an operative procedure, may be used to obtain the bone marrow aspirate. Generally, an accessing device, such as a syringe and needle, may be used to access an intramedullary area of a selected bone. The BMA may then be withdrawn into the syringe for various procedures. Once a selected volume of the BMA is obtained in block **402**, the BMA may be positioned in the separator **10** according to various embodiments in block **404**. The BMA may be positioned in any appropriate separator, such as those described above including the separator **10**. Once the BMA is positioned in the separator **10**, a selected fraction of the BMA may be separated from the BMA in block **406**.

The selected fraction of the BMA may include undifferentiated cells or any appropriate portion of the BMA. The fractionation or separation of various fractions of the BMA may allow for a volume of BMA to be taken from a single location and the separation or concentration of the selected portion may be performed in the separator **10**. Generally, obtaining a small volume of the selected portion from a plurality of locations may be used to obtain an appropriate volume of BMA or selected fraction of the BMA. Nevertheless, the separator **10** may allow for separating a selected volume from a single location from which the BMA is obtained. This may reduce the time of a procedure and increase the efficiency of obtaining the selected fraction of the BMA.

In addition to obtaining a volume of the BMA in block **402**, a volume of whole blood may be obtained in block **408**. The volume of blood obtained in block **408**, according to any appropriate procedure, including those described above, may then be positioned in the separator **10**, in block **410**. The whole blood may be positioned in any appropriate separator, such as those described above or a separator to separate a selected fraction of the whole blood. As described above, the whole blood may be separated into an appropriate fraction, such as a fraction including a platelet portion or buffy coat. The whole blood may be separated into selected fractions in block **412**. It will be understood that the BMA and the whole blood volume may be obtained substantially simultaneously or consecutively in block **402** and **408**. Similarly, the selected fractions of the BMA obtained in block **406** and whole blood obtained in block **412** may also be performed substantially

sequentially or simultaneously. For example, the separator **10** including the volume of the BMA may be positioned in a separating device, such as a centrifuge, substantially opposite, so as to balance, the separator **10** including the volume of the whole blood. Therefore, a single separation, such as centrifuge procedure may be used to separate both the BMA and the whole blood into selected fractions. This again may increase the efficiency of the procedure to provide both a selected fraction of the BMA and a selected fraction of the whole blood substantially simultaneously.

The selected fractions of the BMA and the whole blood, provided in block **406** and **412** may be harvested in block **414**. The selected fractions of the BMA and the whole blood, may be harvested in block **414** for appropriate purposes, such as those described herein. The separator **10** may be used to obtain the selected fractions of the BMA and the whole blood, through various procedures, such as those described above.

After harvesting the selected fractions of the BMA and the whole blood in block **414**, the selected fraction of the BMA may be positioned on an appropriate scaffold in block **416**. The scaffold in block **416** may be any appropriate scaffold, such as synthetic bone substitutes or allogenic tissue. The scaffolds may be used for appropriate procedures, such as hard or soft tissue grafting, including uses in non-union or chronic wounds. The undifferentiated cells of the BMA may allow for a substantial source of cells for use during a substantially natural healing after an operative procedure, for example, the natural healing of a patient may use the supplied undifferentiated cells. Therefore, the scaffold may be positioned in a selected portion of the anatomy and the cells may be allowed to grow and differentiate into selected portions in the implanted position.

In addition to positioning the selected fraction of the BMA and the scaffold in block **416**, the platelets of the whole blood may be positioned on or near the scaffold of block **418**. The platelets of the whole blood fraction positioned in the scaffold of block **418** may assist the undifferentiated cells and the anatomy into which the scaffold is positioned to allow for a substantially efficient and complete healing. The platelet fraction of the whole blood sample may include various healing and growth factors that may assist in providing an efficient and proper healing in the anatomy. Therefore, the undifferentiated cells of the BMA, or other selected fraction obtained from the separation of the BMA, and the selected fraction of the whole blood, obtained from the separator, may be used with the scaffold to provide a substantially efficient implant. In addition, the separator **10**, or any appropriate separator, such as that described above, may allow for a substantially quick and efficient separation of the BMA and the whole blood into an appropriate fraction for use in the procedure.

After the selected portion of the BMA and the whole blood are positioned on the scaffold in blocks **416** and **418** the scaffold may be implanted in block **420**. As described above, the scaffold may be implanted in any appropriate position in the block **420** for various procedures. It will be understood that the scaffold may be implanted for any appropriate procedure and may allow for positioning the selected portion of the BMA, such as undifferentiated cells, and the selected portion of the whole blood, such as platelets, relative to a selected portion of the anatomy. The scaffold may allow for a bone ingrowth, such as allowed with the undifferentiated cells, to assist in healing of a selected portion of the anatomy.

With reference to FIGS. **10A-10C** the separator **10** can include alternative or multiple portions, apparatuses, or systems to assist in removing any selected portion or fraction from the tube **12**. For example, the tube **12** can also include a second port **21**, which may also be referred to as a plasma rich

port (PRP). A second flexible member, such as a flexible tube **21a**, can interconnect the PRP port **21** and the connection portion **324** of the buoy cylinder **306**.

The syringe **204** can be used to introduce a whole sample, such as whole blood, BMA, combinations thereof, or any appropriate material, to the tube **12**, as discussed above. The tube **12** can then be placed in a centrifuge, or similar device, to separate the whole material into selected fractions. As the buoy system **300** moves, as discussed above, the flexible tube **21a** can remain attached to the cylinder **306**. As discussed above, as the centrifuge forces decrease the tube **12** will decompress and assist in holding the buoy system **300** in place, as illustrated in FIG. **10B**.

Once the centrifugation is complete the extraction syringe **340** may be interconnected with the PRP **21** that is interconnected with the connection portion **324** of the buoy cylinder **306** via the flexible member **21a**. As discussed herein the buoy cylinder allows access to the platelet rich area **332** between the buoy portions **302,304**. Thus, it will be understood, that access may be obtained and the platelet rich portion of the sample **332**, between the two buoys **302,304**, may be extracted in a plurality of ways. The illustrations and method described herein are merely exemplary.

Also, the various fractions of, the material can be used for various purposes, including those discussed above and herein. The various fractions that can be created with a separator **10** can be applied to various portions of the patient **350** for selected purposes. For example, the various fractions or components, for example of whole blood, can include various growth factors, anti-infection or anti-microbial components, and other selected portions. These materials can be applied to the patient **350** (FIG. **11**) for various purposes such as infection prevention or reduction, speed healing, speed in growth, and the like.

As discussed above, the platelet rich plasma and the platelet poor plasma can be withdrawn from the separator **10** according to various embodiments. For example, the extraction syringe **340** can be used to extract the platelet rich plasma **332** from the tube **12**. It will be understood that the platelet rich plasma can be formed in any appropriate manner, including according to various embodiments discussed above.

If the platelet rich plasma is withdrawn into the extraction syringe **340**, the extraction syringe can be used to apply a selected material, such as the platelet rich plasma fraction **332** onto the patient **350**.

It will be understood that the platelet rich plasma and the extraction syringe **340** can be mixed with any selected component either during the application, prior to application, or at any appropriate time. For example, the extraction syringe **340** can be interconnected with an application syringe **448** as part of an application system **449**. The application system can be any appropriate application system such as the one provided with the GPSII system sold by Biomet, Inc. It will be understood, however, that the application system **449** can be any appropriate application system.

The application system **449**, can form a mixed spray **S** that can be sprayed onto a selected portion of the patient **350**. For example, during a procedure, such as during a total, partial, or the like knee replacement, a femur **450** and a tibia **452** may be resected for various purposes. The resected portion of the femur **454** and the resected portion of the tibia **456** may have a portion of the mixture, or any appropriate fraction, sprayed thereon for various purposes. For example, the various portions of the whole blood fraction can include growth factors that assist in bony re-growth or healing after the application of

the material. The implant portions can then be positioned relative to the femur **450** and the tibia **452** and healing can occur thereafter.

Further, an incision **458** can be formed through the soft tissue of the patient **350** to gain access to the various portions, such as the femur **450** and the tibia **452**. A portion of the material, such as a mixture of the platelet rich plasma from the extraction syringe **340** can be mixed with a select other components, such as a material positioned in the second syringe application syringe **448** and sprayed onto soft tissue surrounding the incision **458**. The mixture can be any appropriate mixture, a thrombin can be included in this second application syringe **448** and mixed with platelet rich plasma in the extraction syringe **340**. Alternatively, or in addition thereto, various other clotting agents, pharmaceuticals (e.g., antibiotics, medicines and the like) can be included in the second application syringe **448**. Further, any of the selected materials can be mixed with the platelet rich plasma in the extraction syringe **340** and applied to the patient **350** and in any appropriate manner.

It will be understood that the various fractions, such as the platelet poor plasma, the platelet rich plasma, the buffy coat, and the like, can be applied to the patient **350** and can be formed with the separator **10** according to various embodiments. In addition to the various pharmaceuticals, the buffy coat can provide a selected amount of white blood cells to the wound **458**, the resected site **454, 456**, and the like to assist in reducing or inhibiting post-operative infection and can assist with healing after an operative procedure. Nevertheless, the various components can be formed autologously from the patient's whole blood, from their Bone Marrow Aspirate (BMA), or other biological fluids or materials. Therefore, as discussed above, the chance of contamination because of the use of an external source is reduced.

It will be understood that the selected fraction of the component can be applied during any appropriate procedure for purposes such as speed in healing, anti-infection action or the like. For example, the buffy coat, including the selected portion of white blood cells, platelet anti-microbial peptides and the like can be applied during a cesarean section operation, orthopedic operation, cosmetic operative procedures or the like. It will be understood that the various examples are not intended to limit the teachings or applications of the selected materials such as buffy coat, which can be formed with the separator **10**. Further, the additional materials that can be added to the buffy coat fraction, the other fractions, or the like, are also intended to be merely exemplary and not intended to limit the teachings herein.

As discussed above, the various portions or fractions can be used for assisting in healing, regrowth, and infection or the like. As discussed above the fraction, such as the buffy coat, can include high concentrations of white blood cells or other selected blood components. These fractions, such as the white blood cells can assist in anti-infection and healing of a patient or anatomy. For example, the material can assist in reducing infection after an incision is made and during healing.

Also, as discussed above, the selected fraction can be mixed with other materials for application to a patient. For example, the buffy coat can be mixed with other anti-infection materials, such as pharmaceuticals (i.e. antibiotics) to be applied to a surgical site. Nevertheless, as discussed above the materials can be applied to a surgical site, such as a soft tissue incision, a resected bone portion, or the like for various purposes, such as anti-infection, help in healing, or the like.

Various biological materials or factions thereof can be formed according to selected methods and using various

apparatuses. Apparatuses according to various embodiments, including those discussed herein, can be used to separate a selected fraction of a whole material for various purposes. According to the various embodiments discussed above, a buoy or buoy system, that can also be referred to as separation system, can be used to assist in separating a whole material into various and/or plurality of fractions. It will be understood, however, that any appropriate separation system can be provided to assist in separating a material.

For example, with reference to FIG. 12, a buoy or separation system 500 is illustrated. The buoy system 500 can include portions that are similar to portions discussed above, such as the buoy system 300. As discussed above, the buoy system 300 includes a first buoy portion 302 and a second buoy portion 304. The first buoy portion 302 can move relative to the second buoy portion 304 along the connection portion 306. The second buoy portion 304 can seal relative to a portion of the connection portion 306, such as an O-ring or other appropriate sealing interaction, including a tight fit between the second buoy member 304 and the connection member 306.

The buoy system 500, however, can also include a first buoy portion 502 and a second buoy portion 504. The buoy portions 502, 504 can be formed substantially fixed relative to one another with a connection member 506. The connection member 506 can extend along an axis 508 that can be similar to the axis D discussed above. The connection member 506, however, can fixedly interconnect to the first buoy member 502 and the second buoy member 504. During use of the buoy system 500, the buoy portions 502, 504 remain substantially fixed relative to one another such that they are not able to move relative to one another.

Nevertheless, the second buoy member 502 can define a bottom surface 510 that includes features similar to the bottom surface 310. Further, the first buoy portion 502 can also define a collection face 512 that can include features similar to the collection face 308. The second buoy portion 304 can also define a bottom surface 514 that can include any appropriate configuration, such as the bottom surface 316. Nevertheless, the bottom surface 514 of the second buoy portion 504 need not be formed to substantially mate with the collection surface 512 of the first buoy member 502 as the buoy portions are substantially fixed relative to one another.

Further, the buoy system 500 can be formed in various ways. For example, the buoy system can be formed as a single member, formed of a single piece, or can be formed of multiple pieces that are interconnected to form the buoy system 500. Nevertheless, the buoy system 500 can include any selected density or specific gravity, including those discussed above. It can be selected to form the buoy system 500 to include a density that can substantially position the collection face 512 generally below a fraction including the buffy coat of the whole blood sample. It will be understood that such a density can be any appropriate density such as about 1.00 gram per cc to about 1.10 grams per cc. Nevertheless, the entire buoy system 500 can be designed or formed to include the selected density because the portions of the buoy do not move relative to one another. It will be understood, however, that any appropriate portion of the buoy system 500 can be formed to include the selected density.

The connection member 506 defines a central or first bore 516 passing through the connection portion 506. The central bore 516 can interconnect with a second or traversing bore 518 that includes an opening or multiple openings 520 near the collection surface 512. This can allow a material that is collected near the collection surface 512 to be transported through the central bore 516 as discussed above and further

herein. Further, a hose connection 522 can be provided that defines a bore 524 that interconnects with the central bore 516 of the connection member 506. Although the various portions, including the connection member 506 and the tube connection 522 can be formed as a single member with the other portions of the buoy system 500 or can be formed of separate portions that are interconnected.

The second buoy member 504 can be fixedly connected to the connection portion 506 in any appropriate manner. For example, the second buoy portion 504 can be formed as a single member or a single piece with the connection member 506. Further, the second buoy portion 504 can be connected to the connection member 506 using any appropriate method such as welding, adhesives, or any appropriate method. Nevertheless, a gap or passageway 526 can be defined between an inner wall 528 of the second buoy portion 504 in an outer surface 530 of the connection member 506.

The passage 526 can be provided in any appropriate number in or through the second buoy member 504. The passage 526 can be opened at a selected end such as a top end 532 of the second buoy member 504. As discussed herein, this can allow selected materials to pass through the passage 526 at a selected time. A sealing member or check valve 534 can be provided at a second end of the channel 526 such as an area between the bottom surface 514 of the second buoy member 504 and the collection surface 512. The check valve 534 can allow for passage of a selected material upon the application of a force, such as centrifuging, a vacuum, or the like. The check valve 534 can be any appropriate portion, such as a substantially flexible washer or member that is positioned relative to the second buoy portion 504. The check valve 534 can include a washer or flat portion that is formed of any appropriate material such as a silicone material, a rigid material including a living hinge, or any appropriate configuration. Nevertheless, the check valve 534 can allow for a selected passage of a material or an inhibition of a passage of material at a selected time.

With reference to FIG. 13, a buoy system 600, according to various embodiments, can be provided that is similar to the buoy system 500 illustrated in FIG. 12. The buoy system 600 can include portions that are similar to the portions of the buoy system 500 and like reference numerals are used to reference these portions for brevity of the current discussion. For example, the buoy system 600 can include a bottom buoy portion 602, a collection surface 512, a connection member 506, and bores 516 and 518 that pass through the connection portion 506. As discussed above, the bore 518 can terminate or include a passage or opening 520 that can allow access to the internal bores from the collection surface 512. Further, a hose connection 522 can be provided to interconnect with the selected tool and a bore 524 can be provided therein.

The buoy system 600 can also include a second buoy portion 602 that is similar in operation but different in design from the second buoy portion 504. The second buoy portion 602 can include a top surface that includes a geometry and design substantially similar to the second buoy portion 504. A bottom surface 604, however, of the second buoy member 602 can include a first surface portion of 606 that can be substantially flat or perpendicular to a central axis of 608 of the buoy system 600. A second surface portion 610 can also be defined by the second buoy portion 602 that substantially increases a volume between the collection surface 512 and the bottom surface 604 of the second buoy member 602 relative to the second buoy member 504 illustrated in the buoy system 500. It will be understood that the various surfaces 606, 610 can be provided for any appropriate reason, such as providing a selected volume, separating a selected volume, or any appro-

appropriate purpose. Nevertheless, it will be understood that the various portions of the buoy systems according to various embodiments can be configured and designed for any appropriate purpose, such as separating a selected volume of material, achieving or sequestering a selected volume of material, or any other appropriate purpose.

The first buoy portion **502**, second buoy portion **602**, the connecting portion **506**, and the tube connection **522** can be fixed together in any appropriate manner. For example, the various portions can be formed from a single piece such that they are formed as a single member or piece such as with injection molding, machining, or the like. Further, various portions can be interconnected in any appropriate manner, such as welding, adhesives, or the like. Nevertheless, the second buoy portion **602** can include a passage **614** that is similar to the passage **526** of the buoy system **500**.

The passage **614** can be formed and defined between an inner wall **616** of the second buoy member and an outer wall or portion **618** of the connection member **506**. The passage **614** can be open at a top end **620** of the second buoy member **602** and can be closed with a check valve **622** near a bottom end of the passage **614**. The check valve **622** can be similar to the check valve **634** of the buoy system **500** and can be formed of any appropriate material, configuration or the like.

The buoy systems **500**, **600** having been described above include various portions. Although the buoy systems **500**, **600** can be formed of differing materials, designs, or the like, they can be provided in the separator **10** to separate, sequester, and provide a selected material.

With reference to FIGS. **14A-14C**, the buoy system **600** will be described during use for illustration purposes only. It will be understood that the use of the buoy system **600** can be substantially similar to the use of the buoy system **500** and the geometry of the various portions can be selected for various reasons.

With initial reference to FIG. **14A**, the buoy system **600** can be provided in the tube **12** as discussed above. The buoy system **600** can be interconnected with a platelet rich plasma port **21** through the tube **21a** that interconnects with the tube connection **522**. As discussed above, the connection **522** can interconnect with the bores **516** and **518** to obtain access to the collection face **512**. Nevertheless, a selected material, such as a whole blood sample from the syringe **200**, can be positioned within the tube **12**. As discussed above, once the material is positioned within the tube, the separator system **10**, including the tube **12** and the buoy system **600**, can be positioned in the centrifuge for any selected period of time and under selected conditions, including those discussed above. During the centrifugation of the separator system **10**, the walls of the tube **12** may flex, the buoy system **600** may move, and any other appropriate condition may occur, including those discussed above. Nevertheless, the buoy system **600** includes a selected density, specific gravity or other appropriate configuration can move to a selected region within the whole sample positioned within the tube **12**.

As discussed above, a buffy coat fraction or area **332**, that may also be referred to as a platelet rich plasma (PRP), can be substantially defined between an area of the second buoy portion **602** and the first buoy portion **502**. In a region above the second buoy portion **602** near the cap **18**, may be a platelet poor plasma (PPP) or area **334**, as discussed above. The PPP tube **92** can interconnect with the PPP port **20** for access to the PPP fraction **334**.

As discussed above, the buoy system **600** can define a passage **614** or any appropriate number of passages. During the centrifugation process, a portion of the material, such as the PRP **332**, the PPP **334**, or any other appropriate material

may pass through the passage **614** because of the check valve **622**. Therefore, the passage **614** can be provided to allow for ease of separation and movement of the buoy system **600** for various reasons.

After the centrifugation, the buoy system **600** can come to rest at a selected region within the tube **12**, as illustrated exemplary in FIG. **14B**. A syringe or other appropriate device can be interconnected with the PPP port **20** such that the PPP **334** is substantially withdrawn from the tube **12**. It will be understood that the withdrawal tube **92** can extend to substantially near the second buoy portion **602** to allow for a substantially complete withdrawal of the PPP **334**.

As illustrated in FIG. **14C**, once the PPP **334** is substantially removed from the tube **12**, the upper portion of the tube **12** can be filled with an empty space or atmospheric air. Therefore, the two remaining fractions, including various platelet materials **330** and the PRP or a selected middle fraction **332** is left between the buoy portion **602**, **604**. Briefly, it will be understood that the separation system **10** can be used to separate any appropriate material in the separation of a whole blood sample or materials including blood is merely exemplary. Nevertheless, the PRP **332** can be accessed through the PRP tube **21a** that is interconnected with the PRP port **21**.

A withdrawal device or extraction device, such as the syringe **340**, can be interconnected with the PRP port **21**. A vacuum can be formed in the syringe **340** with the plunger **344** such that a vacuum is also formed within the bores **516**, **518** of the connection member **506**. With the vacuum, the PRP **332** can be withdrawn through the opening **520**, the bores **516**, **518**, and the bore **524** through the tube connection **522** and into the syringe **340**. As the material is drawn from the collection face **512**, the check valve **622** can move to allow atmospheric air to enter into the area defined between the surfaces **604**, **610** and the collection face **512**. Because of the check valve **622**, the pressure differential between the area of the collection phase **512** and the atmospheric pressure surrounding tube **12** and other portions can be substantially released as the material is drawn within to the syringe **340**. Therefore, the material can be easily drawn into the syringe **340**, substantially all the material can be drawn into the syringe **340**, and a back pressure is released to maintain the PRP in the syringe **340**.

It will be understood that the buoy systems **500**, **600** can be used with any appropriate system. The separator **10**, according to various embodiments, including those discussed herein, can be provided for various purposes, such as those discussed above. The buoy systems **500**, **600** can be used in the separator **10** as can any of the other appropriate buoy or separation systems. The separation buoy systems **500**, **600** are merely exemplary and not intended to limit the teachings included herein. It will be understood that separator **10** can be used including any appropriate portions to achieve a separation, sequestering, extraction, or the like of any appropriate materials that are positioned within the separator **10**. The discussion of the use of any selected buoy system, also referred to as a separation system, or the like, is merely exemplary and intended to provide various illustrative devices or applications. Nevertheless, the buoy systems **500**, **600** can be provided to achieve selected results in a separation system **10**.

The description of the teachings is merely exemplary in nature and, thus, variations that do not depart from the gist of the teachings are intended to be within the scope of the teachings. Such variations are not to be regarded as a departure from the spirit and scope of the teachings.

What is claimed is:

1. A system for separating and extracting selected fractions from a container, the system comprising:

a separation system, including:

- a first separation member having a first density;
- a second separation member having a second density;
- a connection member having a wall extending a distance and operably interconnecting said first separation member and said second separation member, the wall having an internal surface defining an internal passage and an external surface;

a first collection face defined by said first separation member;

wherein at least one of said first separation member, said second separation member, or both move along said external surface of said connection member;

wherein a selected fraction is operable to be collected in said first collection face between said first separation member and said second separation member, and accessed with the internal passage.

2. The system of claim 1, further comprising: an extraction member;

wherein said extraction member is operable to engage a portion of said connection member and provide a vacuum force through said internal passage of said connection member to assist in extraction of the selected fraction collected in said collection face.

3. The system of claim 1, further comprising: a container;

an extraction port formed through the container to allow access to the interior of the collection face from an exterior of the container; and

an extraction member that interconnects said extraction port and said connection member.

4. The system of claim 3, wherein said extraction member includes a flexible tube interconnecting said extraction port and said connection member.

5. The system of claim 2, further comprising:

a container into which said separation system is placed; wherein said extraction member is operable to maintain a connection with said connection member while said separation system moves within said container, and/or while said first separation member, said second separation member, or both move along said external surface of said connection member.

6. The system of claim 5, wherein said connection member is operable to move within the container and relative to at least one of said first separation member or said second separation member or both and maintain a connection with said extraction member.

7. The system of claim 2, wherein said extraction member includes a tube defining a longitudinal axis that is substantially rigid along the longitudinal axis;

wherein said extraction member is operable to be connected with said connection member directly from an extraction syringe.

8. The system of claim 1, further comprising:

an extraction instrument operable to be connected with said connection member to withdraw a selected volume from between said first separation member and said second separation member through said internal passage.

9. The system of claim 8, wherein said extraction instrument includes a syringe and a tube extending therefrom.

10. The system of claim 9, wherein said tube includes a longitudinal axis;

wherein said tube is substantially rigid along said longitudinal axis.

11. The system of claim 8, wherein said first separation member, said second separation member, or combinations thereof include a buoy moveable within the container;

wherein said extraction instrument is operable to connect with said connection member when said connection member is at any position within the container, wherein said tube of said extraction instrument connects directly with a connection portion of said connection member at least by expanding over said connection portion of said connection member.

12. The system of claim 8, further comprising:

an extraction port extending from the container;

wherein at least a portion of said extraction instrument substantially permanently interconnects said extraction port and said connection member.

13. The system of claim 12, wherein said extraction member defines a throughbore therethrough operable to allow access to an extraction bore extending from said internal passage to a collection volume between said first separation member and said second separation member from said extraction port.

14. The system of claim 1, further comprising:

an extraction instrument;

wherein said extraction instrument is operable to apply at least a portion of the selected fraction onto an anatomy.

15. The system of claim 14, further comprising:

a second component different from said selected fractions; and

a first application system;

wherein said second component and said selected fraction are operable to be mixed and applied with the first application system.

16. The system of claim 15, further comprising:

a second application apparatus;

wherein at least one of the extraction instrument, the first application system, of combinations thereof and the second application apparatus are operable to apply at least the selected fraction onto an anatomy simultaneously with the second component.

17. The system of claim 1, wherein said first separation member has an exterior surface that includes a first separation face that is convex and has a first angle;

wherein said second separation member has a second exterior surface that includes a second separation face that is concave and has a second angle complementary to said first angle;

wherein said connection member includes a catch portion having a surface extending from said connection member to contact said first separation member to limit movement of said first separation member along said connection member.

18. A system for separating and extracting selected fractions from a container, the system comprising:

a separation system, including:

a connection member extending a length between a first end and a second end;

a first separation member having a first density and moveable along said length of said connection member;

29

a second separation member having a second density different than said first density and fixed near said second end of said connection member;  
 wherein said first separation member is operable to move relative to said second separation member along said length of said connection member; 5  
 a collection volume defined between a first collection face of said first separation member and a second collection face of said second separation member;  
 wherein a first selected fraction of the selected fractions is operable to be collected from said collection volume. 10  
**19.** The system of claim **18**, wherein the second density is greater than the first density.  
**20.** The system of claim **19**, further comprising:  
 a connection portion extending from said connection member; and 15  
 a connection member bore defined by an internal wall of said connection member that extends through the connection member and connects with the connection portion to allow permanent access to the collection volume through the connection member and the first separation member. 20  
**21.** The system of claim **20**, further comprising:  
 a flexible tube connecting said connection portion and a platelet rich plasma portion of the container; 25  
 wherein the first selected fraction is operable to be drawn through the flexible tube from the collection volume.  
**22.** The system of claim **21**, further comprising:  
 an extraction port having a member extending from the container; 30  
 wherein the flexible tube extends from the connection portion to the extraction port and interconnects the extraction port and the connection portion;  
 wherein the flexible tube maintains the interconnection during use of the system. 35  
**23.** The system of claim **22**, further comprising:  
 an extraction instrument operable to be connected with said extraction port to withdraw a selected volume from said collection volume between said first separation member and said second separation member. 40  
**24.** The system of claim **23**, wherein said extraction instrument includes a syringe.  
**25.** The system of claim **20**, further comprising:  
 a catch portion including a surface extending away from and connected to an exterior of the connection member operable to engage the first separation member. 45  
**26.** The system of claim **25**, wherein said first separation member contacts said catch portion in a first direction along said connection member and contacts said second separation member in a second direction along said connection member.

30

**27.** A system for separating and extracting selected fractions from a container, the system comprising:  
 a first separation member and a second separation member interconnected with a connection member having a throughbore through the connection member;  
 a collection volume formed between the first separation member and the second separation member within the container;  
 a tube connected to a connection portion of the connection member an extraction system operably connectable to the tube to extract at least one of the selected fractions from the collection volume; and  
 an extraction port extending through a wall of the container to connect the extraction system to form a passage to the collection volume through the connection member;  
 wherein at least a portion of at least one of the selected fractions is contained within the collection volume after a centrifugation of said first separation member, said second separation member, and said connection member within the container;  
 wherein the tube is substantially permanently connected to said connection portion to allow access to the collection area between the first separation member and the second separation member;  
 wherein said first separation member has a first density and said second separation member has a second density that is higher than said first density;  
 wherein the first separation member has a first collection face and the second separation member has a second collection face;  
 wherein the first collection face is a convex surface having a first angle and the second collection face is a concave surface having a second angle, where the first angle and the second angle are substantially complementary.  
**28.** The system of claim **27**, wherein the first separation member is operable to move along the connection member to allow the first collection face to mate with the second collection face of the second separation member.  
**29.** The system of claim **28**, further comprising:  
 a container, and  
 a catch on said connection member,  
 wherein said first separation member has a first exterior wall defining a first buoy within said container and said second separation member has a second exterior wall defining a second buoy in said container;  
 wherein said first buoy and said second buoy move independently of each other along said connection member;  
 wherein said first buoy is operable to contact said catch.

\* \* \* \* \*