

Sept. 21, 1971

D. ARBLASTER

3,606,889

GUARD ACCESSORY FOR CATHETER

Filed July 30, 1969

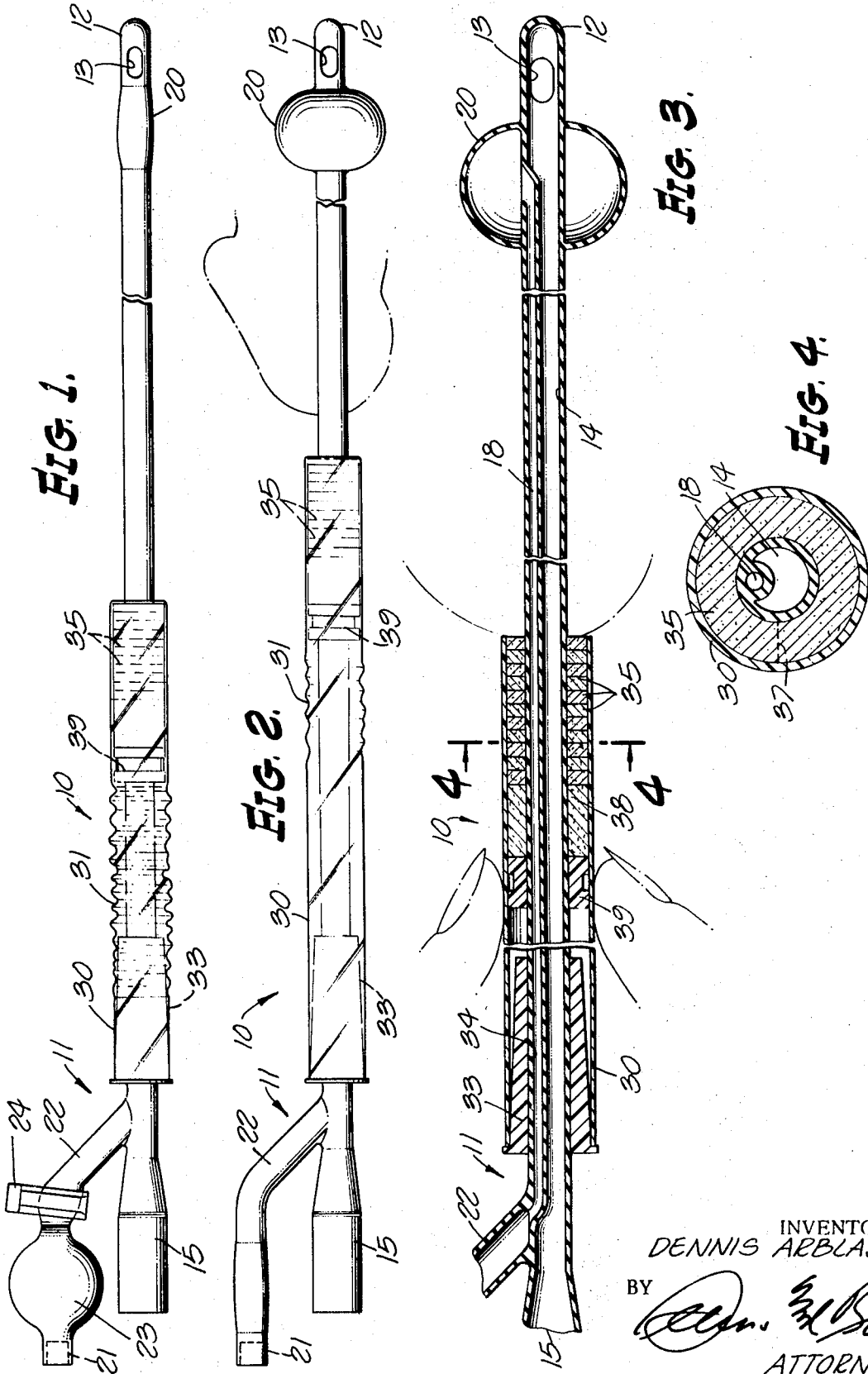

FIG. 1.

FIG. 2.

FIG. 3.

FIG. 4.

INVENTOR
DENNIS ARBLASTER
BY *Dennis Arblaster*
ATTORNEYS

1

3,606,889
GUARD ACCESSORY FOR CATHETER

Dennis Arblaster, 34081 La Serena,
Dana Point, Calif. 92629

Filed July 30, 1969, Ser. No. 846,059

Int. Cl. A61m 25/00

U.S. Cl. 128—349

12 Claims

ABSTRACT OF THE DISCLOSURE

A sterile guard accessory for assembly over the tip end of a retention type catheter to safeguard the sterile condition of the catheter exposed beyond the urethral orifice. The accessory includes a readily expandable and collapsible guard tube enclosing a stack of sterile cushions at its forward end and sized to have a snug fit with the catheter for retention in adjusted position thereon with the advance cushion seated comfortably against the urethral orifice. The cushions are weakened to facilitate detachment of a soiled cushion and exposure of the next sterile cushion. The accessory is equally effective for men and women.

This invention relates to catheters and more particularly to a sterile guard accessory readily installed over a catheter tip and effective in maintaining a substantial exposed length of the catheter sterile over a period of days.

It frequently happens that a patient has need for a retention type catheter. However, doctors are hesitant to use this type because of numerous hazards. The exposed surface of the catheter is unavoidably subject to highly unsanitary conditions providing an excellent vehicle for bacteria to enter the body and cause infection and adding seriously to ailments already undergoing treatment. Various attempts and proposals have been made heretofore in an effort to prolong the sterility of retention catheters but without notable success. In consequence, patients frequently contract additional infections leading to unnecessary and prolonged hospitalization and increased medical costs.

It is a principal object of this invention to avoid the foregoing and other shortcomings of prior practice and to provide a simple, highly effective, sterile guard accessory effective to maintain sterile conditions of a retention catheter throughout its period of installation. The sterile accessory includes a multiplicity of soft medicated cushions held assembled within an impervious supporting tube and having a friction fit with a catheter rearward of its tip. These cushions are usable in succession and fit with the catheter sufficiently firmly as to be retained in any adjusted position therealong with the advance end of a cushion seated against the urethral orifice. The cushions are weakened to facilitate the removal of a soiled cushion and exposing the next sterile cushion for use. Preferably the cushion enclosing tube projects for a considerable distance rearwardly of the supply of cushions and encloses collar means useful in positioning the accessory relative to the urethra. The mid length of this tube is unsupported and free for axial expansion and contraction and its rear end is preferably fitted to a closure plug snugly fitting the catheter.

It is therefore a primary object of the present invention to provide a unique sterile guard accessory for a retention catheter.

Another object of the invention is the provision of a simple, inexpensive, throw away guard accessory insertable over the tip of a catheter for use in maintaining a substantial length of the catheter sterile rearward of the ureter orifice.

2

Another object of the invention is the provision of a catheter sterile guard accessory having a plurality of sterile cushions usable temporarily and in succession against the urethral orifice and including an enclosing tube for the cushions and for a substantial additional rearward length of the catheter.

These and other more specific objects will appear upon reading the following specification and claims and upon considering in connection therewith the attached drawing to which they relate.

Referring now to the drawing in which a preferred embodiment of the invention is illustrated;

FIG. 1 is a side view of the retention catheter showing a preferred embodiment of the invention guard accessory telescoped thereover prior to installation;

FIG. 2 is a view similar to FIG. 1 but showing the catheter in place but prior to forward extension of the guard accessory;

FIG. 3 is a slightly enlarged cross sectional view showing the guard accessory being shifted forward against the urethral orifice; and

FIG. 4 is an enlarged cross sectional view taken along line 4—4 on FIG. 3.

Referring to FIGS. 1 to 3, there is shown a preferred embodiment of the guard accessory, designated generally 10, telescoped over a conventional catheter 11. Such catheters are molded from high grade latex rubber having a tip end 12 provided with an inlet opening 13 in communication with a flow passage 14. The rear end of this passage terminates in an enlarged coupling portion 15 adapted to be assembled over another length of tubing or to a suitable container. Extending along the interior of passage 14 is a relatively small second passage 18 through which water passes to inflate and deflate a thin walled retention balloon 20 formed integral with the tip end of the catheter. Passage 18 opens into a tube 22 provided with any suitable rubber plug 21, or alternatively fitted with a check valve, useful in inflating balloon 20 to support orifice 13 in a proper drainage position and to prevent withdrawal of the catheter. An alternative construction utilizes a water charged bulb 23 for inflation purposes and a spring clip 24 to pinch tube 22 closed and prevent escape of the inflation water from the retention balloon 20 until catheterization is completed. After catheterization spring clip 24 is detached and discarded.

Guard accessory 10 has a thin tubular housing 30 of impervious material, such as plastic film, and its mid portion may be preformed with shallow corrugations 31 to facilitate axial expansion and contraction for reasons which will become apparent presently. The rear end of tube 30 is bonded or otherwise suitably secured to a semi-rigid tubular plug 33 having a central bore 34 sized to fit the main body of the catheter snugly and with a friction fit.

Snugly and frictionally mounted within the forward end of tube 30 is a series or stack of sterilized soft ring cushions 35 likewise having a snug frictional fit with the catheter tube. It will be understood that the number of cushions may vary depending upon the length of time it is intended the catheter will remain in place. This varies from a day or two to a week or ten days in the usual case. Desirably there is at least one cushion 35 for each contemplated 24 hour period of use. Cushions 35 may be formed of any suitable soft, resilient, absorbent material and are of substantial thickness. Preferably the inner or rear face of each cushion includes an impervious coating or film to safeguard against the passage of fluid or foreign matter beyond the foremost cushion.

The porous cushions are preferably impregnated with a non-drying ointment having anti-bacterial and anti-fungal properties. For example the ointment may in-

clude a base containing a wide spectrum antibiotic such as tetracycline, chloromycetin, neomycin, neostorin. Suitable anti-fungicidal ingredients include mycostatin, mycolog, and dioform. It is also important that the ointment be compatible to mucosa likely to be contacted by the ointment.

Preferably each of the cushions 35 is weakened such as by a row of perforations 37 (FIG. 4) to facilitate severance and removal of a used cushion. Desirably, the severance of perforations 37 does not penetrate the impervious layer on the rear face of the cushions.

In contact with the rear end of the stack of cushions 35 is a very substantially thicker ring 38 which may be of the same or slightly firmer material as cushions 35. This ring serves as a pusher or back up for the cushions and has the same internal and external dimensions as the cushions. Rearward of the opening 38 is a collar 39 of elastomeric material having a loose sliding fit with the catheter as well as with the interior of tubular jacket 30. Collar 39 can be grasped between an attendant's thumb and forefinger applied from the exterior side of tube 30 and used to advance ring 38 and the stack of cushions 35 forwardly along the catheter. This operation is facilitated by using the thumb and forefinger of the other hand similarly applied against the sides of closure plug 33 to steady the catheter while the forward end of accessory 10 is being advanced therealong until the outer face of the foremost cushion 35 rests gently against the outer end of the urethral orifice, a position indicated in FIG. 3 by the dot and dash lines.

In use the guard accessory 10 is first applied over the tip end 12 of the catheter as the latter is removed in sterile condition from its shipping container. Initially, accessory 10 is positioned toward the rear end of the catheter body, as is indicated in FIG. 1. The tip is then inserted into the urethra, patient is catheterized, following which balloon 20 is inflated. Thereafter, slight tension is applied to the outer end of the catheter to make certain the balloon is seated against the inlet orifice to the urethra. The operator then manipulates collar 39 while grasping the rear portion of member 33 and forcibly advances the stack of cushions until the foremost cushion 35 is against the urethral orifice, a position best shown in FIG. 3.

After a period of use, preferably not in excess of 24 hours, the forward end of accessory 10 is retracted sufficiently to permit detachment of the soiled cushion, an operation simplified by the presence of a slit or a row of perforations 37. Collar 39 is then manipulated as described above to advance the stack of cushions 35 forwardly within tube 30 until the forward cushion is wholly or at least partially dislodged from tube 30. Further manipulation of collar 39 is then employed to seat the fresh cushion in a comfortable sealing position. The described servicing operations are performed periodically and as necessary until the catheter is removed or until the last of the sterile cushions has been used, and while using sterile gloves.

While the particular guard accessory for catheters herein shown and disclosed in detail is fully capable of attaining the objects and providing the advantages hereinbefore stated, it is understood that it is merely illustrative of the presently preferred embodiments of the invention.

I claim:

1. A sterile guard accessory for protecting the sterile portion of a catheter outwardly of the urethral orifice against contamination, said accessory comprising an elongated tubular member having a central passage sized to have a snug telescopic fit over the advance end of a catheter and to remain in an adjusted position therealong, said tubular member being enclosed by a thin-walled impervious flexible jacket and including a plurality of soft

sterile ring cushions enclosed thereby and the foremost one of which is adapted to seat against the end of the urethral orifice and to be retained in this adjusted position by the frictional fit of said tubular member with the catheter, and said ring cushions being usable in succession to seat against the end of the urethra after the foremost one thereof becomes soiled.

2. A catheter guard accessory as defined in claim 1 characterized in that said soft sterile cushions are stacked in close proximity to one another adapted for successive use against the urethral orifice following removal of the end one thereof after a period of use.

3. A catheter guard accessory as defined in claim 2 characterized in that said cushions are weakened along a line extending crosswise thereof to facilitate the detachment thereof after a period of use.

4. A catheter guard accessory as defined in claim 2 characterized in that said impervious jacket comprises a thin walled tube of impervious material readily removable in short increments to expose successive individual ones of said cushions.

5. A catheter guard accessory as defined in claim 2 characterized in that said impervious jacket projects rearwardly beyond said stack of soft sterile cushions to enclose a substantial length of the catheter, and tubular plug means secured to the rear end of said jacket and having a passage sized to have a snug frictional fit with a catheter.

6. A catheter guard accessory as defined in claim 5 characterized in that a major portion of the mid-length of said impervious jacket is axially expandable and contractible to accommodate shifting one end of said accessory along a catheter independently of the other end thereof.

7. A catheter guard accessory as defined in claim 6 characterized in the provision of collar means loosely enclosed within said impervious jacket rearward of said stack of cushions and adapted to be grasped between the thumb and forefinger and pressed against the rear end of said stack of cushions to advance the stack toward the urethral orifice.

8. A catheter guard accessory as defined in claim 2 characterized in that said sterile cushions include a barrier resistant to the passage of fluid to cushions rearward of the advance cushion.

9. A catheter guard accessory as defined in claim 2 characterized in that said sterile cushions are impregnated with a non-drying medicant ointment.

10. A catheter guard accessory as defined in claim 3 characterized in that said ointment includes an antibiotic.

11. A catheter guard accessory as defined in claim 9 characterized in that said ointment includes an anti-fungicidal agent compatible to mucosa in the vicinity thereof in the installed position of said accessory.

12. A catheter guard accessory as defined in claim 2 characterized in that said cushions include an impervious film on the rear end faces thereof.

References Cited

UNITED STATES PATENTS

1,120,549	12/1914	Schellberg	128—349
2,547,758	4/1951	Keeling	128—349
3,046,988	7/1962	Moreau et al.	128—349X
3,154,080	10/1964	Rowan et al.	128—349
3,185,151	5/1965	Czorny	128—214.4
3,444,860	5/1969	Harrell	128—349
3,487,837	1/1970	Petersen	128—349

DALTON L. TRULUCK, Primary Examiner

U.S. Cl. X.R.

206—63.2