

(19) World Intellectual Property Organization
International Bureau



(43) International Publication Date
2 August 2001 (02.08.2001)

PCT

(10) International Publication Number
WO 01/55863 A1

(51) International Patent Classification⁷: G06F 13/00,
13/14, H04N 7/14

(21) International Application Number: PCT/US01/02881

(22) International Filing Date: 29 January 2001 (29.01.2001)

(25) Filing Language: English

(26) Publication Language: English

(30) Priority Data:
60/178,748 28 January 2000 (28.01.2000) US
60/185,364 28 February 2000 (28.02.2000) US

(71) Applicant: IBEAM BROADCASTING CORPORATION [US/US]; Suite 100, 645 Almanor Avenue, Sunnyvale, CA 94086 (US).

(72) Inventor: LAHR, Nils; Antioch Heights, CA (US).

(74) Agents: BUCZYNSKI, Joseph et al.; Roylance, Abrams, Berdo & Goodman, Suite 600, 1300 19th Street, N.W., Washington, DC 20036 (US).

(81) Designated States (*national*): AE, AG, AL, AM, AT, AT (utility model), AU, AZ, BA, BB, BG, BR, BY, BZ, CA, CH, CN, CR, CU, CZ, CZ (utility model), DE, DE (utility model), DK, DK (utility model), DM, DZ, EE, EE (utility model), ES, FI, FI (utility model), GB, GD, GE, GH, GM, HR, HU, ID, IL, IN, IS, JP, KE, KG, KP, KR, KZ, LC, LK, LR, LS, LT, LU, LV, MA, MD, MG, MK, MN, MW, MX, MZ, NO, NZ, PL, PT, RO, RU, SD, SE, SG, SI, SK, SK (utility model), SL, TJ, TM, TR, TT, TZ, UA, UG, UZ, VN, YU, ZA, ZW.

(84) Designated States (*regional*): ARIPO patent (GH, GM, KE, LS, MW, MZ, SD, SL, SZ, TZ, UG, ZW), Eurasian patent (AM, AZ, BY, KG, KZ, MD, RU, TJ, TM), European patent (AT, BE, CH, CY, DE, DK, ES, FI, FR, GB, GR, IE, IT, LU, MC, NL, PT, SE, TR), OAPI patent (BF, BJ, CF, CG, CI, CM, GA, GN, GW, ML, MR, NE, SN, TD, TG).

Published:

— with international search report

For two-letter codes and other abbreviations, refer to the "Guidance Notes on Codes and Abbreviations" appearing at the beginning of each regular issue of the PCT Gazette.

(54) Title: A SYSTEM AND METHOD FOR PERFORMING BROADCAST-ENABLED DISK DRIVE REPLICATION IN A DISTRIBUTED DATA DELIVERY NETWORK

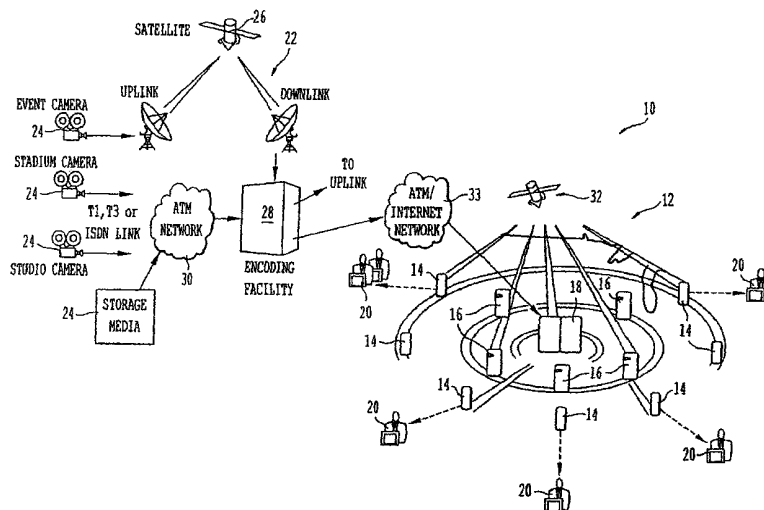

(57) Abstract: A system and method for writing to a disk in real-time at a bitrate which allows streaming of the same payloads over a network connection that supports the same or substantially the same bitrate. The system and method are capable of performing the mirroring or data replication for applications that write to a disk at different or slower rates than other applications in the network. The system and method can employ digital encoders (28) that are advantageous in that they are operable to write to a disk (30) at a specific and substantially constant rate that produce predictable and consistent results. A disk driver employed in the system and method enables an application to read and write to a disk (130) as if it were a normal disk drive. As the application reads and writes content to the disk drive, the network transparently broadcasts the content via TCP/IP to remote listening devices (14).



WO 01/55863 A1

A SYSTEM AND METHOD FOR PERFORMING BROADCAST-ENABLED DISK
DRIVE REPLICATION IN A DISTRIBUTED DATA DELIVERY NETWORK

5

BACKGROUND OF THE INVENTION

Field of the Invention:

The present invention relates to a method and system for replicating data
10 while transparently broadcasting data via TCP/IP to remote nodes in a network. More
particularly, the present invention relates to a method and system for distributing data as
streaming data at a desired bitrate data to servers in a distributed data network, while
writing the data to a data storage, such as a disk, at substantially the same bitrate, to thus
efficiently replicate the data.

15

Description of the Related Art:

In recent years, the Internet has become a widely used medium for communicating
and distributing information. Currently, the Internet can be used to transmit multimedia data,
20 such as streaming audio and video data, from content providers to end users, such as
businesses, small or home offices, and individuals.

As the use of the Internet increases, the Internet is becoming more and more
congested. Since the Internet is essentially a network of connected computers distributed
throughout the world, the activity performed by each computer or server to transfer
25 information from a particular source to a particular destination naturally increases in
conjunction with increased Internet use. Each computer is generally referred to us as a
“node” with the transfer of data from one computer or node to another being commonly
referred to as a “hop.”

A user connecting to a Web site to read information is concerned with how quickly
30 the page displays. Each Web page usually consists of 20-30 objects, and loading each
object requires a separate request to the Web server. It can easily be determined how
many visitors can access the content on a Web server at one time by examining the
number of objects on a Web page. For example, if a Web page has 50 objects and a
Pentium 233 network can handle approximately 250-300 URL connections a second, six
35 people can access the server simultaneously and have the objects delivered in a timely

manner. Once the entire page is delivered, there is no further interaction with the server until the user clicks on an object on the page. Until such action occurs, the server can process requests from other users.

5 Users expect a page to load quickly when they connect to a Web site, just as they expect the light to come on when they flip a switch, or a dial tone to sound when they pick up the phone, Internet users are increasingly expecting the page they request to load immediately. The more objects on the Web page, the longer it takes the contents of the page to load entirely. A page with 50 objects needs to connect with the server 50 times. Although the latency between connections is milliseconds, the latency can accumulate to a
10 degree where it is unacceptable to a user.

A user connecting to a streaming media server, on the other hand, is concerned with the smoothness of the stream being viewed. Typically, only one connection is made for each video stream, but the connection to the server must be maintained for the duration of the stream. In a streaming media network, a persistent connection exists between the
15 client and server. In this environment, a more important metric is the number of concurrent users (clients) that can connect to the server to watch a stream. Once the connection is made, a server plays the stream until it is completed or is terminated by a user.

Accordingly, in a streaming network, latency is not the dominant concern. Once the connection is established, streaming occurs in real time. A slight delay in establishing
20 the connection is acceptable because the viewer will be watching the stream for a while. It is more important that there be a persistent connection. Also, once viewers incur the delay at the request time, they are watching the stream in a slightly delayed mode. The main concern while watching a stream is jitter and packet loss.

As can be appreciated from the above, due to the huge volume of data that each
25 computer or node is transferring on a daily basis, it is becoming more and more necessary to minimize the amount of hops that are required to transfer data from a source to a particular destination or end user, thus minimizing the amount of computers or nodes needed for a data transfer. Hence, the need exists to distribute servers closer to the end users in terms of the amounts of hops required for the server to reach the end user.

30 In addition, in a Newark of the type described above, it can be beneficial to replicate or "mirror" the content to facilitate content distribution. Mirroring is a method of

replicating data from one location to one or more other locations, and is typically performed using an I/O-based method which is not very scalable and generally does not work across an IP network. Further, mirroring may not be transparent, that is, systems that mirror can take “snap-shots” of the disk and replicate this data out to other storage devices.

5 Some systems may mirror in real-time in that, as soon as the file is opened and being written to, the data is being replicated onto the other storage devices. Full mirroring is a method that replicates an entire set of data, while recently partial mirroring is a method that replicates only selected materials and is helpful in creating a more dynamic and scalable network.

10 Mirroring is increasingly being implemented as selective replication that can include push technologies, as well as large content management networks that replicate according to complex networking relationships and formulas. A need therefore exists for a method of mirroring which reduces problems created by selective replication across large and diverse networks.

15

SUMMARY OF THE INVENTION

An object of the present invention is to provide a system and method for efficiently and effectively mirroring content in a distributed data network.

20 A further object of the present invention is to provide a system and method capable of mirroring content to different storage medium in a distributed network at different duplication rates.

25 These and other objects are substantially achieved by providing a system and method for writing to a disk in real-time at a bitrate which allows streaming of the same payloads over a network connection that supports the same or substantially the same bitrate. The system and method are capable of performing the mirroring or data replication for applications that write to a disk at different or slower rates than other applications in the network. The system and method can employ digital encoders that are advantageous in that they are operable to write to a disk at a specific and substantially
30 constant rate that produce predictable and consistent results.

5 These and other objects are also substantially achieved by providing a disk driver that enables an application to read and write to a disk as if it were a normal disk drive. As the application reads and writes content to the disk drive, the network transparently broadcasts the content via TCP/IP to remote listening devices, such as edge servers in the network. A remote device can include, for example, another disk driver that then writes the data to disk or a remote application that simply uses the information being broadcast. By saving the broadcast information back to the disk, a remote listening device can recreate the file being created by the source application.

10

BRIEF DESCRIPTION OF THE DRAWINGS

These and other objects, advantages and novel features of the invention will be more readily appreciated from the following detail description when read in conjunction with the accompanying drawings, in which:

15 Fig. 1 is a conceptual block diagram illustrating an example of a network according to an embodiment of the present invention;

Fig. 2 is a conceptual block diagram of an example of a media serving system in accordance with an embodiment of the present invention;

20 Fig. 3 is a conceptual block diagram of an example of data center in accordance with an embodiment of the present invention;

Fig. 4 is a diagram illustrating an example of data flow in the network shown in Fig. 1 in accordance with an embodiment of the present invention;

Fig. 5 is a diagram illustrating an example of content flow in the network shown in Fig. 1 in accordance with an embodiment of the present invention;

25 Figs. 6, 7 and 8 illustrate acquisition, broadcasting and reception phases employed in the network shown in Fig. 1 in accordance with an embodiment of the present invention;

Fig. 9 illustrates an example of transport data management that occurs in the network shown in Fig. 1 in accordance with an embodiment of the present invention;

30 Fig. 10 illustrates an example of the distribution and operation of the director in the network shown in Fig. 1 in accordance with an embodiment of the present invention; and

Fig. 11 is a conceptual diagram illustrating different media delivery scenarios performed by the network shown in Fig. 1 under different conditions.

Throughout the drawing figures, like reference numerals will be understood to refer to like parts and components.

5

DETAILED DESCRIPTION OF THE PREFERRED EMBODIMENTS

An example of a network 10 according to an embodiment of the present invention is shown in Fig. 1. As described in more detail below, the network 10 captures content, such as multimedia data, using, for example, a dedicated or private network. The network 10 then broadcasts the content by satellite, asynchronous transfer mode (ATM) network or any other suitable network, to servers located at the edge of the Internet, that is, where users 20 connect to the Internet such as at a local Internet service provider (ISP). The network 10 therefore bypasses the congestion and expense associated with the Internet backbone to deliver high-fidelity streams with high quality of service (QOS) and at low cost to servers located as close to end users 20 as possible.

To maximize performance, scalability and availability, the network 10 deploys the servers in a tiered hierarchy distribution network indicated generally at 12 that can be built from different numbers and combinations of network building components comprising media serving systems 14, regional data centers 16 and master data centers 18. The master data centers 18 are configured to support enormous numbers of requests for streaming media and thus, is the first layer of redundancy for handling requests by end users from the Internet in general. The regional data centers 16 are strategically disposed at major "backbone" points across the Internet, and service traffic from within one subnetwork on the Internet to use within the same subnetwork, thus preventing the content of the data from being subjected to problems and idiosyncrasies associated with private and public peering which can occur on the Internet as can be appreciated by one skilled in the art. The regional data centers 16 are also capable of serving high volumes of data streams. The media serving systems 14, which make up the third layer of the network 10, are disposed within the access providers' points of presence (POPs) which are generally less than two router hops away from the end

user 20. These media serving systems 14 are generally not subject to any of the idiosyncrasies of the Internet, and thus can be scaled to meet the needs of the specific POP.

Although only one master data center 18 is illustrated, it is to be understood that the network 10 can employ multiple master data centers 18, or none at all, in which event
5 the network 10 can simply employ regional data centers 16 and media serving systems 14 or only media serving systems 14. Furthermore, although the network 10 is shown as being a three-tier network comprising a first tier having one or more master data centers 18, a second tier having regional data centers 16, and a third tier having media serving systems 14, the network 10 can employ any number of tiers.

10 The network 10 also comprises an acquisition network 22 that is preferably a dedicated network for obtaining media or content for distribution from different sources. As discussed in more detail below, the acquisition network 22 can further operate as a network operations center (NOC) which manages the content to be distributed, as well as the resources for distributing the content. For example, as discussed in more detail below,
15 content is preferably dynamically distributed across the network 12 in response to changing traffic patterns in accordance with an embodiment of the present invention.

An illustrative acquisition network 22 comprises content sources 24, such as content received from audio and/or video equipment employed at, for example, an event, for a live broadcast via satellite 26. Live or simulated live broadcasts can also be rendered
20 via stadium or studio cameras 24, for example, and transmitted via a terrestrial network such as a T1, T3 or ISDN or other type of a dedicated network 30 that employs asynchronous transfer mode ATM technology. In addition to live analog or digital signals, the content can be provided from storage media 24 such as analog tape recordings, and digitally stored information (e.g., media-on-demand or MOD), among other types of
25 content. Further, in addition to a dedicated link 30 or a satellite link 26, the content harvested by the acquisition network 22 can be received via the internet, other wireless communication links besides a satellite link, or even via shipment of storage media containing the content, among other methods.

As further shown, the content is provided via the satellite uplink and downlink, or
30 by the ATM 30, to an encoding facility 28. The encoding facility 28 is capable of operating continuously and converts in excess of, for example, 40 megabits/second of raw

content such as digital video into Internet-ready data in different formats such as the Microsoft Windows Media (MWM), RealNetworks G2, or Apple QuickTime (QT) formats, to name a few. The network 10 employs unique encoding methods to maximize fidelity of the audio and video signals that are delivered.

5 With continued reference to Fig. 1, the encoding facility 28 provides encoded data to the hierarchical distribution network 12 via a broadcast backbone which is preferably a point-to-multipoint distribution network such as a satellite link 32, an ATM 33 or a hybrid fiber-satellite transmission circuit, which would be, for example, a combination of satellite link 32 and ATM 33. The satellite link 32 is preferably dedicated and independent of a
10 satellite link 26 employed for acquisition purposes. The satellite delivery of the data leverages the economy of scale realizable through known broadcast technology, and further, bypasses the slower and costlier terrestrial backbone of the Internet to provide the end user with consistent and faster Internet performance, which results in lower bandwidth costs, better quality of service, and offer new opportunities. The satellite downlink can also has the
15 capability for handling Ku, S, and C bands, as well as DSS.

 The package delivery software employed in the encoding facility 28 allows the data files to be distributed by multicast UDP/IP, TCP/IP, or both, as can be appreciated by one skilled in the art. Also, the package delivery software includes a queuing server as well as a retransmission server that cooperate to transmit the data and quickly recover any lost data
20 packets. This recovery scheme results in smoother delivery of streaming audio, video and multimedia data to the Internet. The tiered network building components 14, 16 and 18 are each preferably equipped with satellite receivers to allow the network 10 to simultaneously deliver live streams to all server tiers 14, 16 and 18 and rapidly update on-demand content stored at any tier as described in more detail below. When a satellite link 32 is unavailable
25 or impractical, however, the network 10 can broadcast live and on-demand content though fiber links provided in the hierarchical distribution network 12.

 As discussed in more detail below, the network employs a director to monitor the status of all of the tiers 14, 16 and 18 of the distribution network 12 and redirect users 20 to the optimal server depending on the requested content. The director can originate, for
30 example, from the NOC at the encoding facility 28. The network employs an internet protocol or IP address map to determine where a user 20 is located and then identifies

which of the tiered servers 14, 16 and 18 can deliver the highest quality stream, depending on network performance, content location, central processing unit load for each network component, application status, among other factors.

Media serving systems 14 comprise hardware and software installed in ISP facilities at the edge of the Internet. The media serving systems 14 preferably only serve users 20 in its subnetwork. Thus, the media serving systems 14 are configured to provide the best media transmission quality possible because the end users 20 are local. A media serving system 14 is similar to an ISP caching server, except that the content served from the media serving network is controlled by the content provider that input the content into the network 10. The media serving systems 14 each serve live streams delivered by the satellite link 32, and store popular content such as current and/or geographically-specific news clips. Each media serving system 14 manages its storage space and deletes content that is less frequently accessed by users 20 in its subnetwork. Content that is not stored at the media serving system 14 can be served from regional data centers 16.

Certain details and features of the media serving systems 14, regional data centers 16 and master data centers 18 will now be described. As shown in Fig. 2, a media serving system 14 comprises an input 40 from a satellite receiver and/or terrestrial signal receiver (not shown) which are configured to receive broadcast content from encoding facility 28 as described above with regard to Fig. 1. The media serving system 14 can output content to users 20 in its subnetwork, or can output control/feedback signals for transmission to the NOC in the encoding facility 28 or to another hierarchical component in the network 10 via wireline or wireless communication network. The media serving system 14 further includes a central processing unit 42 which controls operation of the media serving system 14, a local storage device 43 for storing content received at input 40, and a file transport module 44 and a transport receiver module 45 which operate to facilitate reception of content from the broadcast backbone. The media serving system 14 also preferably comprises one or more of an HTTP/Proxy server 46, a Real server 48, a QT server 50 and a WMS server 52 to provide content to users 20 in a selected format.

As shown in Fig. 3, a regional data center 16 comprises front-end equipment to receive an input from a satellite receiver and/or terrestrial signal receiver and to output content to users 20 or control/feedback signals for transmission to the NOC or another

hierarchical component in the network 10 via wireline or wireless communication network. Specifically, a regional data center 16 preferably has more hardware than a media serving system 14 such as gigabit routers and load-balancing switches 66 and 68, along with high-capacity servers (e.g., plural media serving systems 14) and a storage device 62. The CPU 60 and host 64 are operable to facilitate storage and delivery of less frequently accessed on-demand content using the servers 14 and switches 66 and 68.

As discussed in more detail below, the regional data centers 16 also deliver content to a user 20 if a standalone media serving system 14 is not available to that particular user 20, or if that media serving system 14 does not include the content requested by the user 20. That is, the director at the encoding facility 28 preferably continuously monitors the status of the standalone media serving systems 14 and reroutes users 20 to the nearest regional data center 16 if the nearest media serving system 14 fails, reaches its fulfillment capacity or drops packets. Users 20 are typically assigned to the regional data center 14 that corresponds with the Internet backbone provider that serves their ISP, thereby maximizing performance of the second tier of the distribution network 12. The regional data centers 14 also serve any users 20 whose ISP does not have an edge server.

The master data centers 18 are similar to regional data centers 16, except that they are preferably much larger hardware deployments and are preferably located in a few peered data centers and co-location facilities, which provide the master data centers with connections to thousands of ISPs. Therefore, Fig. 3 is also used to illustrate an example of components included in a master data center 18. However, it is noted that a master data center 18 comprises multiterabyte storage networks (e.g., a larger number of media serving systems 14) to manage large libraries of content created, for example, by major media companies. As discussed in more detail below, the director at the encoding facility 28 automatically routes traffic to the closest master data center 18 if a media serving system 14 or regional data center 16 is unavailable to a user, or if the user has requested content that is not available at its designated media serving system or regional data center 16. The master data centers 18 can therefore absorb massive surges in demand without impacting the basic operation and reliability of the network.

The flow of data and content will now be discussed with reference to Figs. 4-8. As shown in Figs. 4 and 5, the internet broadcast network 10 for streaming media generally

comprises three phases, that is, acquisition 100, broadcasting 102 and receiving 104. In the acquisition phase 100, content is provided to the network from different sources such as internet content providers (ICPs) or event or studio content sources 24, as shown in Fig. 1. As stated previously, content can be received from audio and/or video equipment employed at a stadium for a live broadcast. The content can be, for example, live analog signals, live digital signals, analog tape recordings, digitally stored information (e.g., media-on-demand or MOD), among other types of content. The content can be locally encoded or transcoded at the source using, for example, file transport protocol (FTP), MSBD or real-time transport protocol/ real-time streaming protocol (RTP/RTSP).

The content is collected using one or more acquisition modules 106 which are described in more detail below in connection with Fig. 6. The acquisition modules 106 represent different feeds to the network 10 in the acquisition network 22 shown in Fig. 1, and the components of the acquisition modules 106 can be co-located or distributed throughout the acquisition network 28. Generally, acquisition modules 106 can perform remote transcoding or encoding of content using FTP, MSBD, or RTP/RTSP or other protocols prior to transmission to a broadcast module 110 for multicast to edge devices and subsequent rendering to users 20 located relatively near to one of the edge devices. The content is then converted into a broadcast packet in accordance with an embodiment of the present invention. This process of packaging packets in a manner to facilitate multicasting, and to provide insight at reception sites as to what the packets are and what media they represent, constitutes a significant advantage of the network 10 over other content delivery networks.

Content obtained via the acquisition phase 100 is preferably provided to one or more broadcast modules 110 via a multicast cloud or network(s) 108. The content is unicast or preferably multicast from the different acquisition modules 106 to the broadcast modules 110 via the cloud 108. As stated above, the cloud 108 is preferably a point-to-multipoint broadcast backbone. The cloud 108 can be implemented as one or more of a wireless network such as a satellite network or a terrestrial or wireline network such as optical fiber link. The cloud 108 can employ a dedicated ATM link or the internet backbone, as well as a satellite link, to multicast streaming media. The broadcast modules 110 are preferably in tier 120, that is, they are at the encoding center 28 that receive

content from the acquisition modules 106 and, in turn, broadcast the content via satellite 32, ATM/Internet network 33, or both, to receivers at the media serving systems 14, regional data centers 16, and master data centers 18 (see Fig. 1) in tiers 116, 118 and 120, respectively (see Fig. 5).

5 During the broadcasting phase 102, broadcast modules 110 operate as gatekeepers, as described below in connection with Fig. 7, to transmit content to a number of receivers in the tiers 116, 118 and 120 via paths in the multicast cloud 108. The broadcast modules 110 support peering with other acquisition modules indicated generally at 112. The peering relationship between a broadcast module 110 and an acquisition module 112 can
10 occur via a direct link, and each device agrees to forward the packets of the other device and to otherwise share content directly across this link, as opposed to across a standard Internet backbone.

 During the reception phase 104, high-fidelity streams that have been transmitted via the broadcast modules 110 across the multicast cloud 108 are received by servers at the
15 at the media serving systems 14, regional data centers 16, and master data centers 18 in tiers 116, 118 and 120, respectively, with the media serving systems 14 being as close to end users as possible. The network 10 is therefore advantageous in that streams can bypass congestion and expense associated with the Internet backbone. As stated previously, the media serving systems 14, regional data centers 16 and master data centers
20 18 that correspond to tiers 116, 118 and 120, respectively, provide serving functions (e.g., transcoding from RTP to MMS, RealNet, HTTP, WAP or other protocol), as well as delivery via a local area network (LAN), the internet, a wireless network or other network to user devices 20, identified collectively as users 122 in Figs. 4 and 5 which include PCs, workstations, set-top boxes such as for cable, WebTV, DTV, and so on, telephony devices,
25 and the like.

 With reference to Figs. 6-8, hardware and software components associated with the acquisition 100, broadcasting 102 and reception phases 104, as used in the network 10 of the present invention, will now be described in more detail. The components comprise various transport components for supporting media on demand (MOD) or live stream
30 content distribution in one or multiple multicast-enabled networks in the network 10. The transport components can include, but are not limited to, a file transport module, a

transport sender, a transport broadcaster, and a transport receiver. The content is preferably characterized as either live content and simulated/scheduled live content, or MOD (i.e., essentially any file). Streaming media such as live content or simulated/scheduled live content are managed and transported similarly, while MOD is
5 handled differently as described in more detail below.

Acquisition for plural customers A through X is illustrated in Fig. 6. By way of an example, acquisition for customer A involves an encoder, as indicated at 134, which can employ Real, WMT, MPEG, QT, among other encoding schemes with content from a source
24. The encoder also encodes packets into a format to facilitate broadcasting in accordance
10 with the present invention. A disk 130 stores content from different sources and provides MOD streams, for example, to a disk host 132. The disk host 132 can be proxying the content or hosting it. Live content, teleconferencing, stock and weather data generating systems, and the like, on the other hand, is also encoded. The disk host 132 unicasts the MOD streams to a file transport module 136, whereas the encoder 134 provides the live
15 streams to a transport sender 138 via unicast or multicast. The encoder can employ either unicast or multicast if QT is used. Conversion from unicast to multicast is not always needed, but multicast-to-multicast conversion can be useful. The file transport module 136 transfers MOD content to a multicast-enabled network. The transport sender 138 pulls stream data from a media encoder 134 or an optional aggregator and sends stream
20 announcements (e.g., using session announcement protocol and session description protocol (SAP/SDP)) and stream data to multicast internet protocol (IP) addresses and ports received from a transport manager, which is described in more detail below with reference to Fig. 9. When a Real G2 server is used to push a stream, as opposed to a pulling scheme, an aggregator can be used to convert from a push scheme to a pull
25 scheme. The components described in connection with Fig. 6 can be deployed at the encoding center 28 or in a distributed manner at, for example, content provider facilities.

Fig. 5 illustrates an exemplary footprint for one of a plurality of broadcasts. As shown in Fig. 5, the broadcasting phase 102 is implemented using a transport broadcaster 140 and a transport bridge 142. These two modules are preferably implemented as one
30 software program, but different functions, at a master data center 18 or network operations center. The transport broadcaster 140 performs transport path management, whereas the

transport bridge 142 provides for peering. The broadcaster 140 and bridge 142 get data from the multicast cloud (e.g., network 108) being guided by the transport manager and forward it to an appropriate transport path. One transport broadcaster 140, for example, can be used to represent one transport path such as satellite uplink or fiber between data centers or even a cross-continental link to a data center in Asia from a data center in North America. The broadcaster 140 and bridge 142 listen to stream announcements from transport senders 138 and enable and disable multicast traffic to another transport path, accordingly. They can also tunnel multicast traffic by using TCP to send stream information and data to another multicast-enabled network. Thus, broadcast modules 110 transmit corresponding subsets of the acquisition phase streams that are sent via the multicast cloud 108. In other words, the broadcast modules 110 operate as gatekeepers for their respective transport paths, that is, they pass any streams that need to be sent via their corresponding path and prevent passage of other streams.

As stated above, Fig. 8 illustrates an example the reception phase 104 at one of a plurality of servers or data centers. As stated above, the data centers are preferably deployed in a tiered hierarchy comprising media serving systems 14, regional data centers 16 and master data centers 18. The tiers 116, 118 and 120 each comprise a transport receiver 144. Transport receivers can be grouped using, for example, the transport manager. Each transport receiver 144 receives those streams from the broadcast modules 110 that are being sent to a group to which the receiver belongs. The transport receiver listens to stream announcements, receives stream data from plural transport senders 138 and feeds the stream data to media servers 146. The transport receiver 144 can also switch streams, as indicated at 154 (e.g., to replace a live stream with a local MOD feed for advertisement insertion purposes). The MOD streams are received via the file transport 136 and stored, as indicated via the disk host 148, database 150 and proxy cache/HTTP server 152. The servers 146 and 152 can provide content streams to users 20.

The transport components described in connection with Figs. 6-8 are advantageous in that they generalize data input schemes from encoders and optional aggregators to data senders, data packets within the system 10, and data feeding from data receivers to media servers, to support essentially any media format. The transport components preferably

employ RTP as a packet format and XML-based remote procedure calls (XBM) to communicate between transport components.

The transport manager will now be described with reference to Fig. 9 which illustrates an overview of transport data management. The transport manager is preferably
5 a software module deployed at the encoding facility 28 or other facility designated as a NOC. Multiple content sources 24 (e.g., database content, programs and applications) provide content as input into the transport manager 170. Information regarding the content from these data sources is also provided to the transport manager such as identification of
10 input content source 24 and output destination (e.g., groups of receivers). Decisions as to where content streams are to be sent and which groups of servers (e.g., tiers 116, 118 or 120) are to receive the streams can be predefined and indicated to the transport manager 170 as a configuration file or XBM function call in real-time, for example, under control of the director as discussed in more detail below. This information can also be entered via
15 a graphical user interface (GUI) 172 or command line utility. In any event, the information is stored in a local database 174. The database 174 also stores information for respective streams relating to defined maximum and minimum IP address and port ranges, bandwidth usage, groups or communities intended to receive the streams, network and stream names, as well as information for user authentication to protect against unauthorized use of streams or other distributed data.

20 With continued reference to Fig. 9, a customer requests to stream content via the system 10 using, for example, the GUI 172. The request can include the customer's name and account information, the stream name to be published (i.e., distributed) and the IP address and port of the encoder or media server from which the stream can be pulled. Requests and responses are sent via the multicast network (e.g., cloud 108) using separate
25 multicast addresses for each kind of transport component (e.g., a transport sender channel, a broadcaster channel, a transport manager channel and a transport receiver channel), or one multicast address and different ports. An operator at the NOC can approve the request if sufficient system resources are available such as bandwidth or media server capacity. The transport manager 170 preferably pulls stream requests periodically. In response to an
30 approved request, the transport manager 170 generates a transport command in response to the request (e.g., an XML-based remote procedure call (XBM)) to the transport sender 138

of the acquisition module 106 (see Fig. 6) corresponding to that customer which provides the assigned multicast IP address and port that the transport sender is allowed to use in the system 10. The transport sender 138 receives the XBM call and responds by announcing the stream that is going to be sent, and all of the transport components listen to the
5 announcement.

As discussed above and in more detail below, once the transport sender 138 commences sending the stream into the assigned multicast IP address and port, the transport broadcaster 140 of the corresponding broadcast module 110 (see Fig. 7) will filter the stream. The transport receiver 144 of the appropriate tier or tiers 116, 118 or 120
10 (see Fig. 8) joins the multicast IP address and receives the data or stream if the stream is intended for a group to which the receiver 144 belongs. As stated above in connection with Fig. 8, the transport receiver 144 converts the stream received via the cloud 108 and sends it to the media server available to the users 20. The data is then provided to the media server associated with the receiver. Receivers 144 and broadcasters 140 track
15 announcements that they have honored using link lists.

As stated above, the transport components preferably use RPT as a data transport protocol. Accordingly, Windows Media, RealG2 and QT packets are wrapped into RTP packets. The acquisition network 22 preferably employs an RTP stack to facilitate processing any data packets, wrapping the data packets with RTP header and sending the
20 data packets. RTSP connection information is generally all that is needed to commence streaming.

RTP is used for transmitting real-time data such as audio and video, and particularly for time-sensitive data such as streaming media, whether transmission is unicast or multicast. RTP employs User Datagram Protocol (UDP), as opposed to
25 Transmission Control Protocol (TCP) that is typically used for non-real-time data such as file transfer and e-mail. Unlike with TCP, software and hardware devices that create and carry UDP packets do not fragment and reassemble them before they have reached their intended destination, which is important in streaming applications. RTP adds header information that is separate from the payload (e.g., content to be distributed) that can be
30 used by the receiver. The header information is merely interpreted as payload by routers that are not configured to use it.

RTSP is an application-level protocol for control over the delivery of data with real-time properties and provides an extensible framework to enable controlled, on-demand delivery of real-time data including live feeds and stored clips. RTSP can control multiple data delivery sessions, provide means for choosing delivery channels such as UDP, multicast UDP and TCP, and provide means for choosing delivery mechanisms based on RTP. HTTP is generally not suitable for streaming media because it is more of a store-and-forward protocol that is more suitable for web pages and other content that is read repeatedly. Unlike HTTP, RTSP is highly dynamic and provides persistent interactivity between the user device (hereinafter referred to as a client) and server that is beneficial for time-based media. Further, HTTP does not allow for multiple sessions between a client and server, and travels over only a single port. RTP can encapsulate HTTP data, and can be used to dynamically open multiple RTP sessions to deliver many different streams at the same time.

The system 10 employs transmission control software deployed at the encoding facilities 28, which can operate as a network operations center (NOC), and at broadcast modules 110 (e.g., at the encoding facility 28 or master data centers 18) to determine which streams will be available to which nodes in the distribution system 12 and to enable the distribution system 12 to support one-to-one streaming or one-to-many streaming, as controlled by the director. The extensible language capabilities of RTSP augment the transmission control software at the edge of the distribution network 12. Since RTSP is a bi-directional protocol, its use enables encoder modules 134 (see Fig. 6) and receiver modules 144 (see Fig. 8) to talk to each other, allowing for routing, conditional access (e.g., authentication) and bandwidth control in the distribution network 12. Standard RTSP proxies can be provided between any network components to allow them to communicate with each other. The proxy can therefore manage the RTSP traffic without necessarily understanding the actual content.

Typically, for every RTSP stream, there is an RTP stream. Further, RTP sessions support data packing with timestamps and sequence numbers. RTP packets are wrapped in a broadcast protocol. Applications in the receiving phase 104 can use this information to determine when to expect the next packet. Further, system operators can use this

information to monitor network 12 and satellite 32 connections to determine the extent of latency, if any.

Encoders and data encapsulators written with RTP as the payload standard are advantageous because off-the-shelf encoders (e.g., MPEG2 encoders) can be introduced without changing the system 10. Further, encoders that output RTP/RTSP can connect to RTP/RTSP transmission servers. In addition, the use of specific encoder and receiver combinations can be eliminated when all of the media players support RTP/RTSP.

As can further be appreciated from the above, the encoding facility 28 operates as a non-distributed application to write its content to a disk, such as disk 130 (see Fig. 6), and distributes the content to a possible infinite number of listening devices, such as edge servers (e.g., media serving systems 14) in the network 10. These listening devices can then either recreate the file and the data on a local drive as if the application was running local to it, or simply use the sent data within a remote application. Accordingly, this allows for programs not designed for a broadcast and distributed networks to be used on a broadcast and distributed network.

Again, as discussed above, encoder module 134 (see Fig. 6) can write a live stream to disk 130 while also broadcasting a live stream to the network 12. After writing the initial file header, the encoder module 134 can save small chunks of data to the disk 130 for each few segments of audio or video it encodes. By broadcasting the low-level information about the creation of this file, and all the data being written to it, a remote application or disk driver at, for example, a media serving system 14, can re-create the file in near real-time. That is, at a remote server at the media serving system 14, the file will start to be created at nearly the same rate by which it was being saved to the disk. This occurs because when an encoder is encoding a live signal, it will only write to the disk at the same or substantially the same bitrate at which it is encoding. For example, a 300k encoded stream will be written at approximately 300k to the local disk. By intercepting the low-level commands to the disk, this 300k data stream to the disk can be sent via a 300k IP broadcast. Remote devices, such as media serving systems 14, can then listen to the stream and write the data to a local disk at the same or substantially the same 300k rate it at which it is being broadcast.

The manner in which streams and content are distributed throughout the tiers 116, 118 and 120 will now be further described with reference to Figs. 10 and 11.

As discussed above, the master data centers 18 are configured to support enormous numbers of requests for streaming media and thus, is the first tier 120 of redundancy for handling requests by end users from the Internet in general. The regional data centers 16 make up the second tier 118 and are strategically disposed at major "backbone" points across the Internet. The regional data centers 16 service traffic from within one subnetwork on the Internet to use within the same subnetwork, thus preventing the content of the data from being subjected to problems and idiosyncrasies associated with private and public peering which can occur on the Internet as can be appreciated by one skilled in the art. The regional data centers 16 are also capable of serving high volumes of data streams. The media serving systems 14, which make up the third tier 116 of the network 100, are disposed within the access providers' points of presence (POPs) which are generally less than two router hops away from the end user. These media serving systems 14 are generally not subject to any of the idiosyncrasies of the Internet, and thus can be scaled to meet the needs of the specific POP.

The master data centers 18, in conjunction with the encoding facility, include a includes the director, which includes a distributed server application. The director can poll information about the network 10 from a plurality of sources in the network 10 from other directors present at the regional data centers 16 and media serving systems 14, and can use this information to determine or modify the positions in the streaming data at which data received from content providers should be placed, so as to best distribute that data to the regional data centers 16 and media serving systems 14.

Referring to Fig. 1, under control of the director, the encoder 28 uplinks data received from content providers to the master data center or centers 18, the regional data servers 16 and the media serving systems 14 via satellite 32, ATM/Internet network 33, or both. The components of the network 10 cooperate as discussed above to insure that the correct multicast stream reaches every server in the network 10. Also, the satellite delivery of the data leverages the economy of scale realizable through known broadcast technology, and further, bypasses the slower and costlier terrestrial backbone of the Internet to provide the end user with consistent and faster Internet performance, which results in lower bandwidth

costs, better quality of service, and offer new opportunities. The package delivery software employed at the encoding facility allows the data files to be distributed by multicast UDP/IP, TCP/IP, or both, as can be appreciated by one skilled in the art. Also, the package delivery software includes a queuing server as well as a retransmission server that cooperate to
5 transmit the data and quickly recover any lost data packets. This recovery scheme results in smoother delivery of streaming audio, video and multimedia data to the Internet.

The encoding facility 28 distributes content to tiers 116, 118 and 120 to insure that the data from the content providers are efficiently and cost-effectively multicast out to all three tiers of the network 10 simultaneously. As shown in Fig. 10, the director constantly
10 monitors the network and adapts to changes, ensuring the quality of applications run on the network 10. As further shown, relay software is distributed throughout the network 10 to provide a reliable transport layer that makes sure no packets get lost across the broadcast backbone. The transport layer also lets applications scale connections from one-to-few to one-to-many. In addition to receiving and unpacking data from the broadcast backbone, the
15 relay software manages local storage and reports to the director on the status of the remote server and its applications.

A distribution engine located at, for example, the encoding facility 28, operates periodically to analyze server logs generated and received from other tiers of the network 10, that is, from the regional data centers 16 and from the media serving systems 14, and
20 determines which files to send based on cache engine rules, for example (i.e., the number of times a file was requested by users, file size, largest amount of storage at a remote site in the network 10, and so on). Based on this analysis, the broadcasting module 110 (see Fig. 7) performs serving and head-end functions, as well as streaming content directing functions, in order to transfer data to the regional data centers 16 and media serving systems 14

25 For example, when a particular multimedia data event (e.g., a video clip) is first provided via a content provider, that particular video clip will reside at the master data centers 18. Because presumably little or no statistics on the popularity of the video clip will be available initially, the analysis performed by the distribution engine will result in the distribution engine placing the video clip at a low priority position or, in other words, near
30 the end of the data stream to be distributed. Because the servers at the regional data centers 16 and media serving systems 14 generally do not have sufficient data storage capacity to

store all data in the data stream that they receive, these servers will most likely be unable to store and thus serve this video clip. That is, those servers generally will be able to store data at the beginning portion of the data stream, and will therefore disregard data more toward the end of the stream.

5 Accordingly, any request by a user for that video clip will be satisfied by a server at a master data center 18. Specifically, the director will provide a metatag file to the requesting user 20 which will enable the user 20 to link to the appropriate server at the master data center 18 from which the user 20 can receive the requested video clip.

10 However, as more and more users request the particular video clip, the statistics on this new data clip will become available, and can be analyzed by the distribution engine. As the popularity of the video clip increases, the distribution engine will place the video clip in a higher priority location in the video stream or, in other words, closer to the beginning of the video stream each time the video stream is transmitted to the regional data centers 16 and media serving systems 14. As stated above, the regional data centers 16 have memory
15 sufficient to store subsets of the content available from the master data centers 18. Similarly, the media serving systems 14 also each have memory to store subsets of content that has been prioritized by the master data centers 18 to the extent of the memory capacity at the edge devices and ISP POPs.

20 The content at the devices in tiers 116 and 118 is dynamically replaced with higher prioritized content. Thus, as the video clip is moved closer to the beginning of the data stream, the likelihood that the video clip will be among the data that can be stored at the regional data centers 16 and media serving systems 14 increases. Eventually, if the video clip is among the most popular, it will be positioned by the distribution engine near the beginning of the data stream, and thus, become stored at all or most of the regional data
25 centers 16 and media serving systems 14.

30 As discussed above, the director is an intelligent agent that monitors the status of all tiers 116, 118 and 120 of the network 10 and redirects users to the optimal server. The director uses an IP address map to determine where the end user 20 is located, and then identifies the server that can deliver the highest quality stream. The server choice is based on network performance and where the content is located, along with CPU load, application status, and other factors.

When an end user 20 requests a stream, the director determines the best server on the network 10 from which to deliver the streaming media data. Although at times the server that is physically closest to the end user can be the most appropriate choice, this is not always the case. For example, if a media serving system 14 local to an end user is being
5 overburdened by a current demand for data, and an additional request is received from that end user within the same POP, that media serving system 14 would likely not be the best choice to provide the data request.

The director therefore runs a series of queries when determining from which server a particular data stream should be provided to a particular end user. Specifically, the director
10 at the tier 120 (master data center) level will query directors at its “children” servers, which are the regional data centers 16. The directors at the regional data centers 16 will query directors at their “children” servers, which are their respective media serving systems 14. This queried information is provided by the directors at the media serving systems 14 to their
15 respective regional data centers 16, which then provided that queried information along with their own queried information to the director at the master data centers 18. Based on this information, the director at the master data centers 18 can determine which server is best suited to satisfy the user request. Once that determination is made, the director at the master data centers 18 provides the appropriate metatag file to the user, to thus enable the user to
20 link to the appropriate server represented by the metatag file (e.g., one of the media serving systems 14 that is close to the requesting user and available) so that the user can receive the requested video clip from that server.

As explained above, the director at the master data center 18 tier uses the queried data to determine stream availability or, in other words, whether a data stream exists within a particular POP or content hosting center associated with that server. The director determines
25 the stream platform, such as whether the data stream is windows media or real G2. The director also determines stream bandwidth conditions, which indicate whether the data stream is a narrow bandwidth stream or a broad bandwidth stream. The director also inquires as to the performance of the server to assess whether the server and network are capable of serving that particular type of data stream. In addition, the director determines
30 network availability by determining whether a particular master data center 18, regional data centers 16 or media serving system 14 is available from a network standpoint.

It is noted that not all type of servers on the network 10 will necessary carry all types of data streams. Certain classes of data content might only be served to end users from the master data centers 18 or regional data centers 16. Therefore, it is important that the director does not direct a data request to a server that does not support the particular data content requested by a user.

The platform for the data stream is also particularly important. From a real server licensing prospective, the network 10 needs to assure that data conformity is maintained. This concern does not occur with a windows media platform. However, there are specific servers within in the master data centers 18 and regional data centers 16 that only serve windows media or real G2.

Stream bandwidth is also important to determine the best server to which to direct data requests. The director needs to assure that high bandwidth stream requests are directed to the highest performance locations on the network, and, in particular, the highest performance media serving systems 14 and regional data centers 16.

One problem with media servers is that the tools for determining current server performance are minimal, at best. Hence, in a distributed network such as network 10, it is crucial that the exact state of each server is known on a continued basis, so that the director can make the correct decisions if the server should receive additional requests. The director therefore has specific tools and utilities to assess the current state of any server, as well as the number of current streams being served and the bandwidth of those streams. These tools report back current server state information that the director evaluates when determining the best server from which data should be provided in response to a particular user request. Example of scenarios in which the director will determine from which server a data request should be handled for a particular user will now be described with reference to Fig. 11.

Full Decision Scenario #1

User A (see Fig. 11) tries to requests a video stream

Network Availability: *False*

Director will never see request since user has no

connectivity to Internet and because link between
Edge Server #1 and Regional #1 is down

Result: User A will not be able to receive the stream even
though there is a Media Server within its POP

5

Full Decision Scenario #2

User B (see Fig. 11) requests a 100kb Real Video Stream

Network Availability: True

10 *Server Availability:* Regional #1 and Master Data Center #1

Stream Availability: Stream exists in both locations

Stream Bandwidth: Both sites can serve stream bandwidth

Server Performance: Both available to serve stream

Result: User directed to Real Server in Regional #1

15

Full Decision Scenario # 3

User C (see Fig. 11) requests a 300kb Windows Media Stream

Network Availability: True to Edge #1, Master #1; False to Master #2

20 *Server Availability:* Edge #1 Master #1

Stream Availability: Stream exists on both Servers

Stream Bandwidth: Edge #1 can serve stream bandwidth; Master #1 can't

Server Performance: Edge #1 available to serve stream

Result: User directed to Windows Media Server in Edge #1

25

Full Decision Scenario #4

User D (see Fig. 11) requests 100kb Windows Media Stream

Network Availability: True to Regional #3, Regional #4 and to Master #2

30 *Server Availability:* Regional #4 and Master #2

Server Availability: Stream exists on Master #2

Stream Bandwidth: Master #2 can serve stream bandwidth
Server Performance: Master #2 available to serve stream
Result: User directed to Windows Media Server in Master #2

5 Full Decision Scenario #5

User E requests 100kb Real G2 Stream

Network Availability: True to Regional #3, and to Master #2

Server Availability: Master #2

Stream Availability: Stream exists on server

10 *Stream Bandwidth:* Master #2 can serve stream bandwidth

Server Performance: Master #2 available to serve stream

Results: User directed to Real Server in Master #2

15 Although the present invention has been described with reference to a preferred embodiment thereof, it will be understood that the invention is not limited to the details thereof. Various modifications and substitutions will occur to those of ordinary skill in the art. All such substitutions are intended to be embraced within the scope of the invention as defined in the appended claims.

What is Claimed is:

1. A system, adapted for use with a distributed data delivery network, for duplicating data being distributed in the network, comprising:

5 a data storage; and

a data distributor, adapted to distribute data as streaming data at a first bitrate to at least one data server in the network, while writing said data to said data storage at substantially said first bitrate.

10 2. A system as claimed in claim 1, wherein:

said data distributor comprises an encoder, adapted to encode said data to create said streaming data at said first bitrate.

3. A system as claimed in claim 1, wherein:

15 said data storage includes a disk, and said data distributor is adapted to write said data to said disk at substantially said first bitrate.

4. A system as claimed in claim 1, wherein:

said data storage is disposed at a data server in said network.

20

5. A system as claimed in claim 1, wherein:

said data storage is disposed at one of said at least one data server in said network.

6. A system as claimed in claim 1, further comprising:

25 a reader, adapted to read said data stored at said data storage at a read rate substantially equal to said first bitrate.

7. A method for duplicating data being distributed in a distributed data delivery network, comprising:

30 distributing data as streaming data at a first bitrate to at least one data server in the network; and

writing said data to a data storage at substantially said first bitrate while performing said distributing step.

8. A method as claimed in claim 7, wherein:

5 said data distributing step includes encoding said data to create said streaming data at said first bitrate.

9. A method as claimed in claim 7, wherein:

said data storage includes a disk; and

10 said data distributing step includes writing said data to said disk at substantially said first bitrate.

10. A method as claimed in claim 7, wherein:

said data storage is disposed at a data server in said network; and

15 said writing step writes said data to said data storage disposed at said data server.

11. A method as claimed in claim 7, wherein:

said data storage is disposed at one of said at least one data server in said network;

and

20 said writing step writes said data to said data storage disposed at said one of said at least one data server.

12. A method as claimed in claim 7, further comprising:

reading said data stored at said data storage at a read rate substantially equal to said

25 first bitrate.

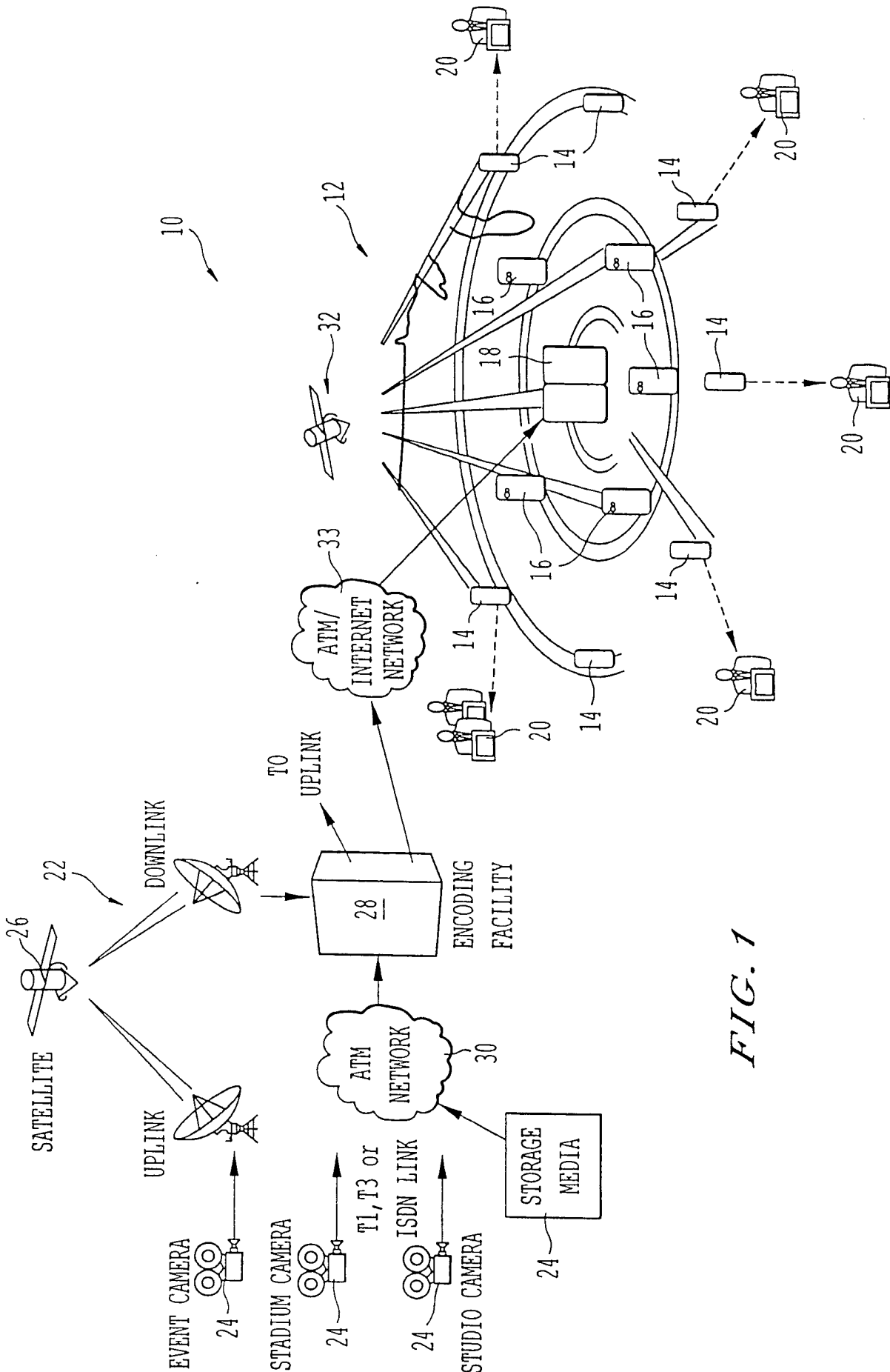

FIG. 1

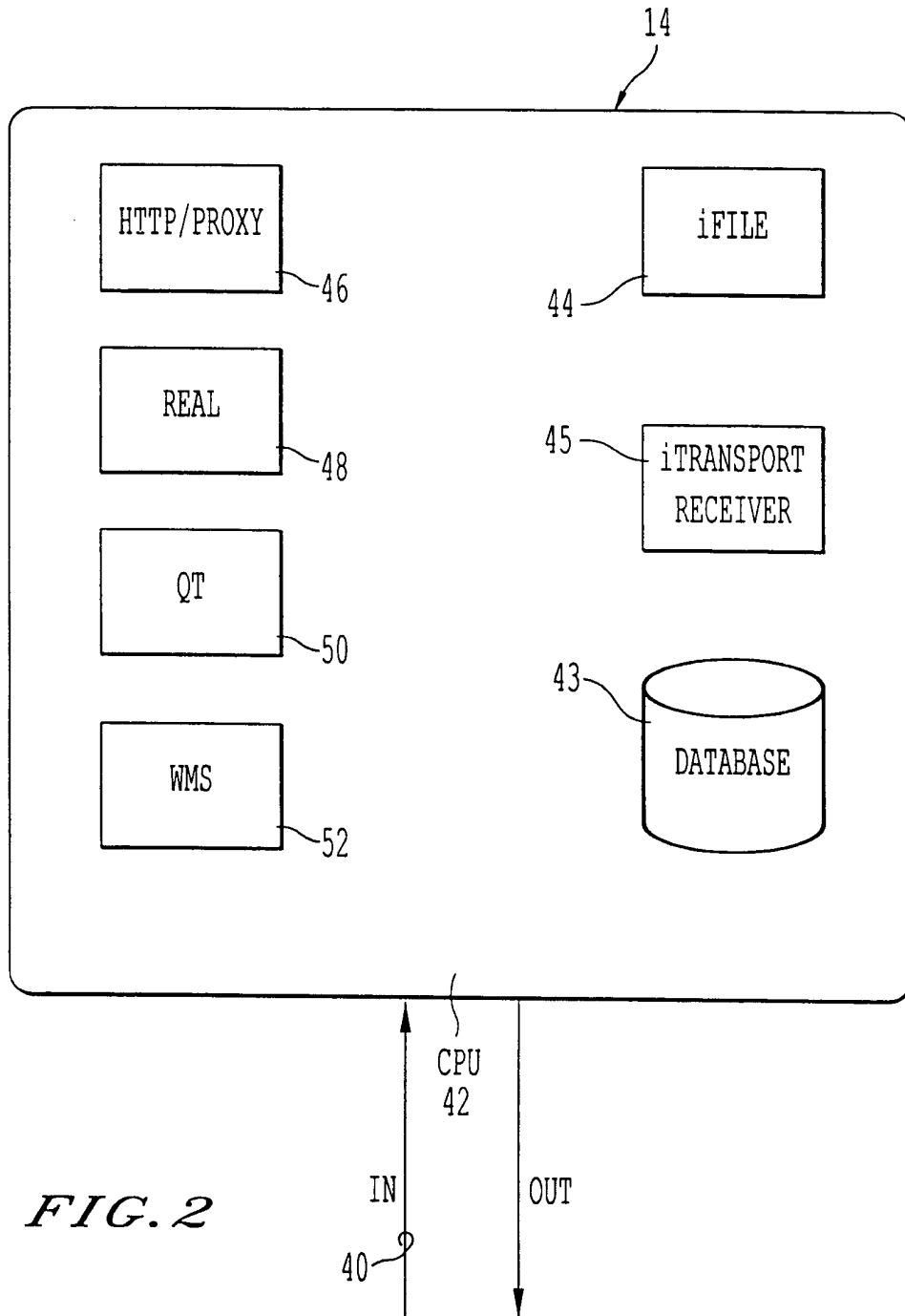

FIG. 2

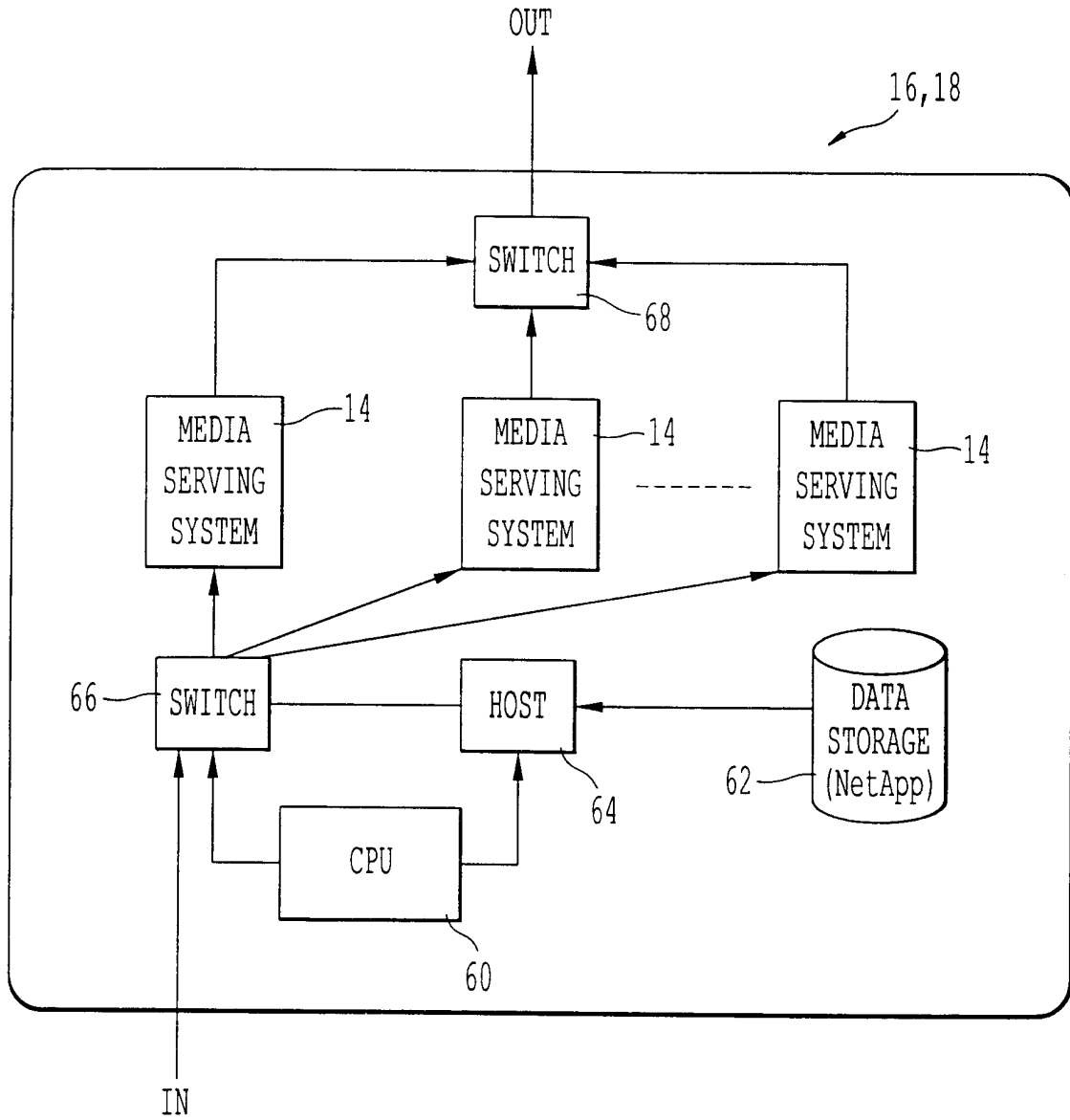

FIG. 3

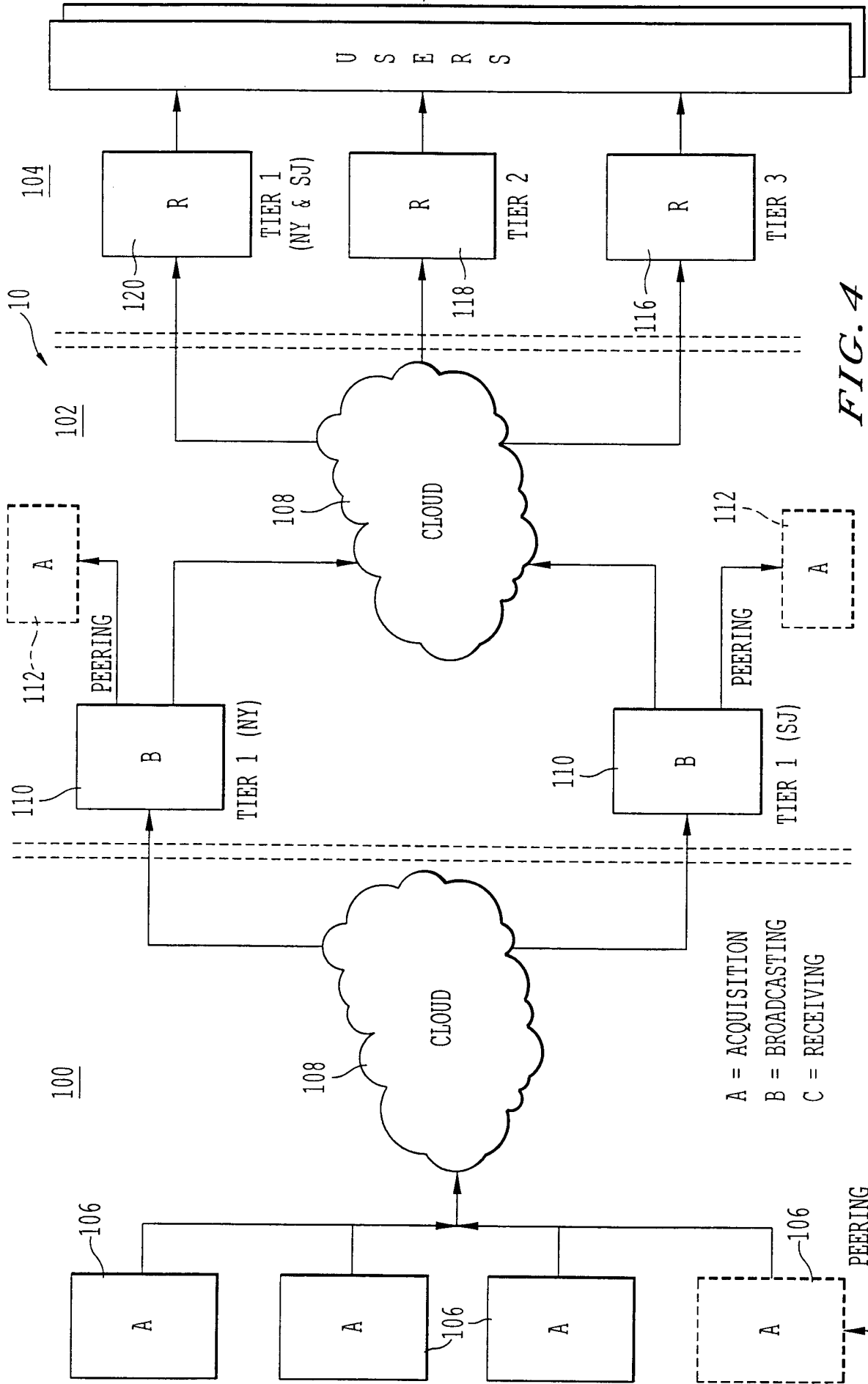

FIG. 4

A = ACQUISITION
 B = BROADCASTING
 C = RECEIVING

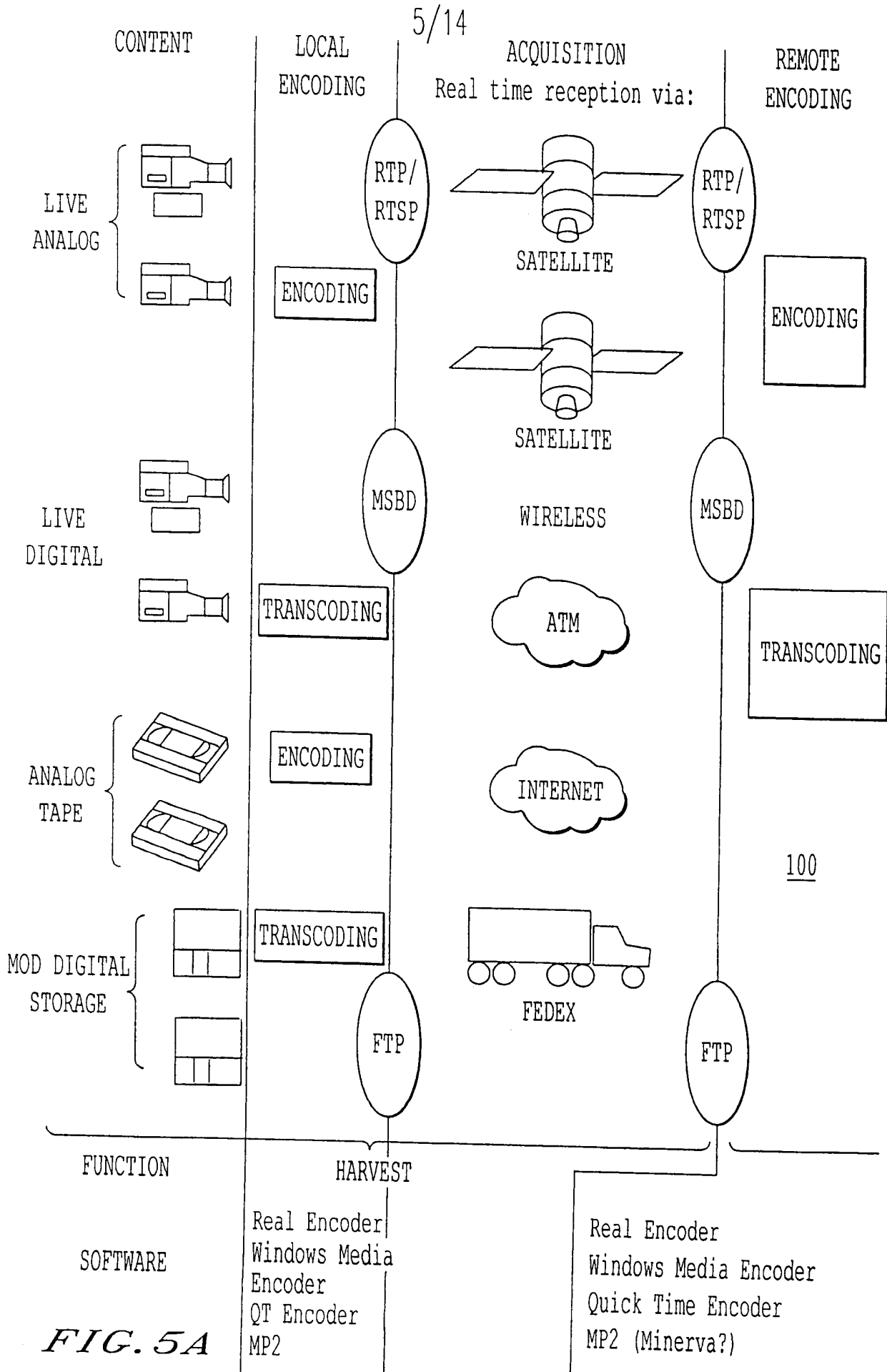

FIG. 5A

6/14

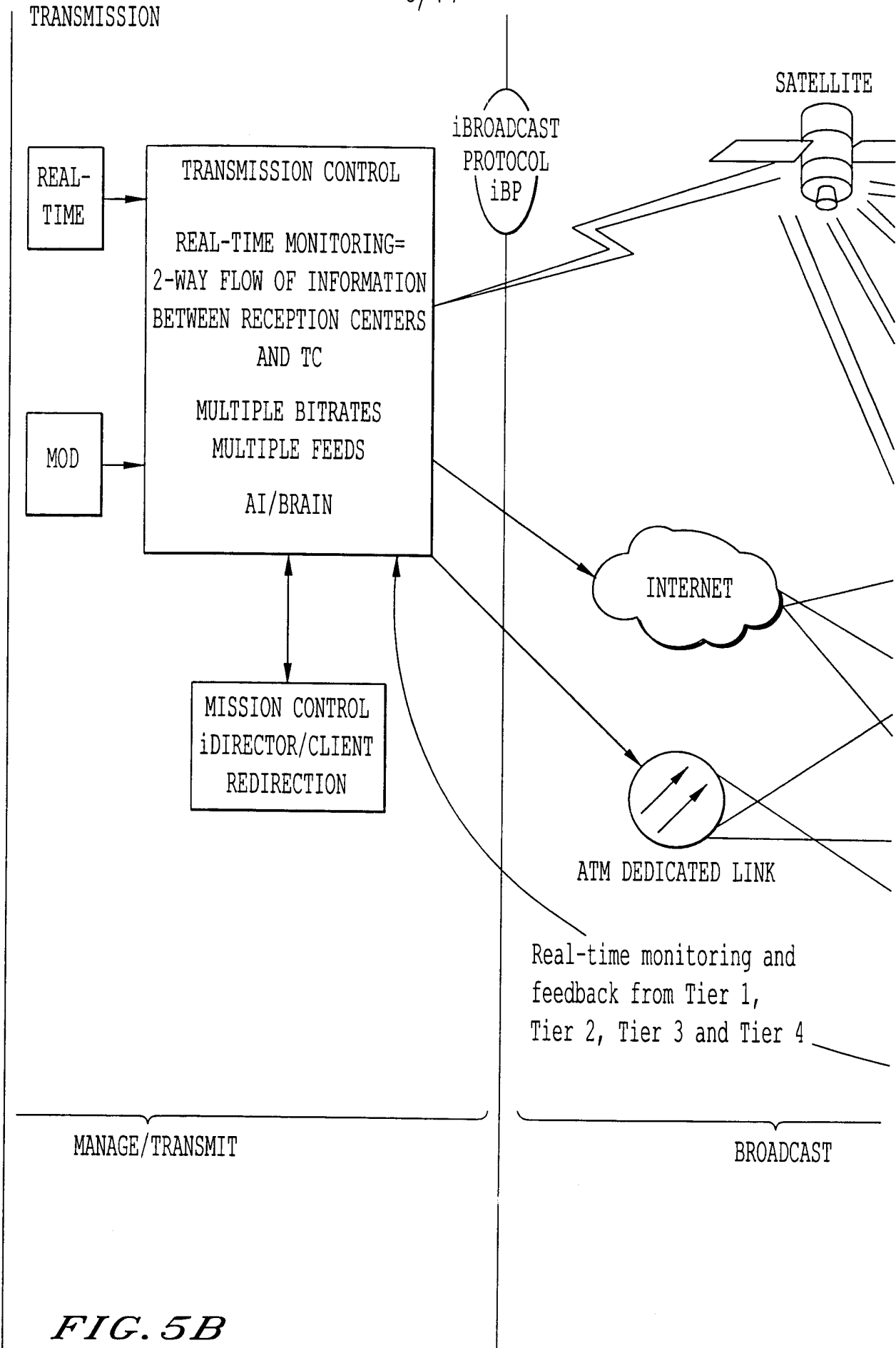

FIG. 5B

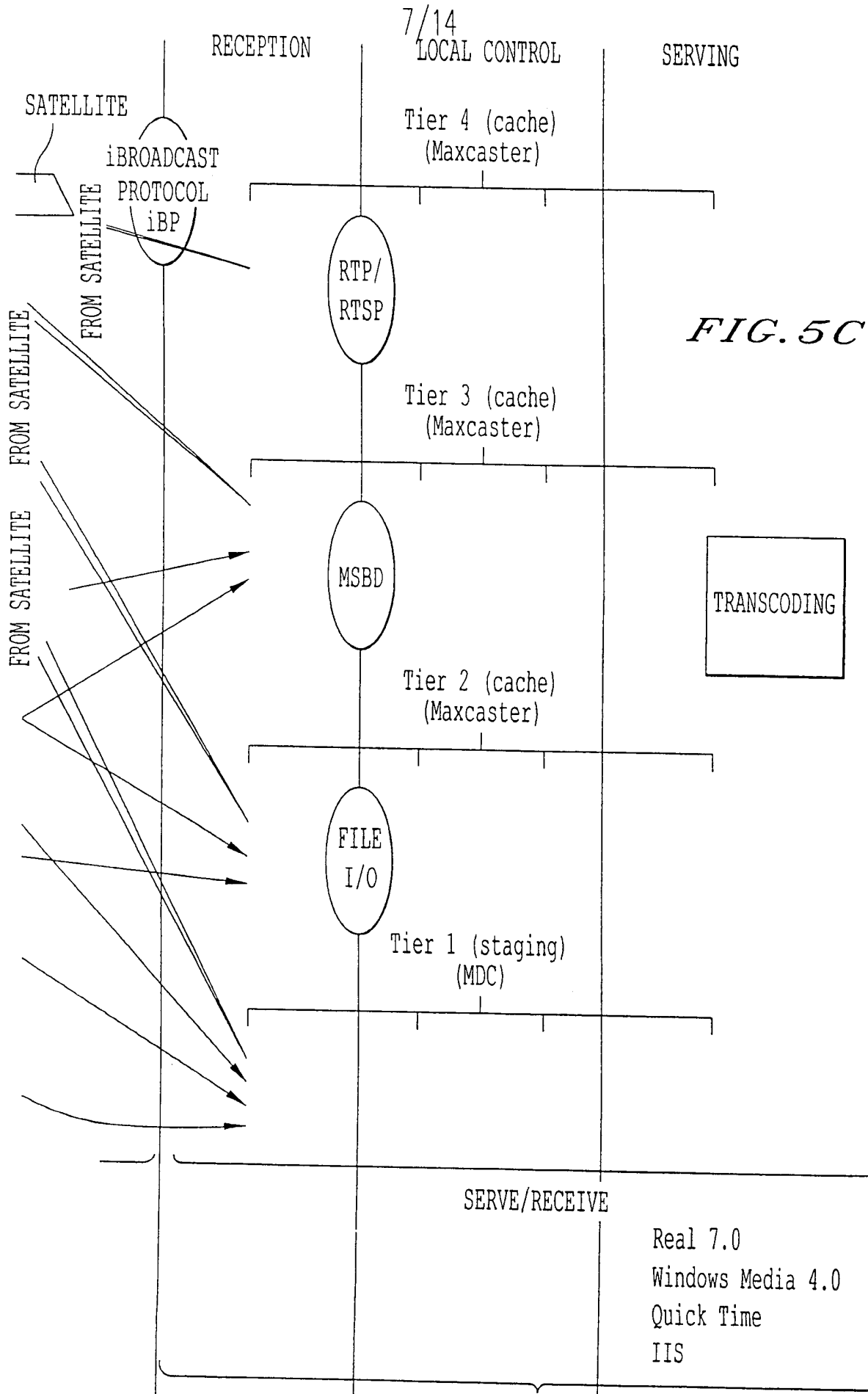

FIG. 5C

8/14
DELIVERY

PLAYBACK

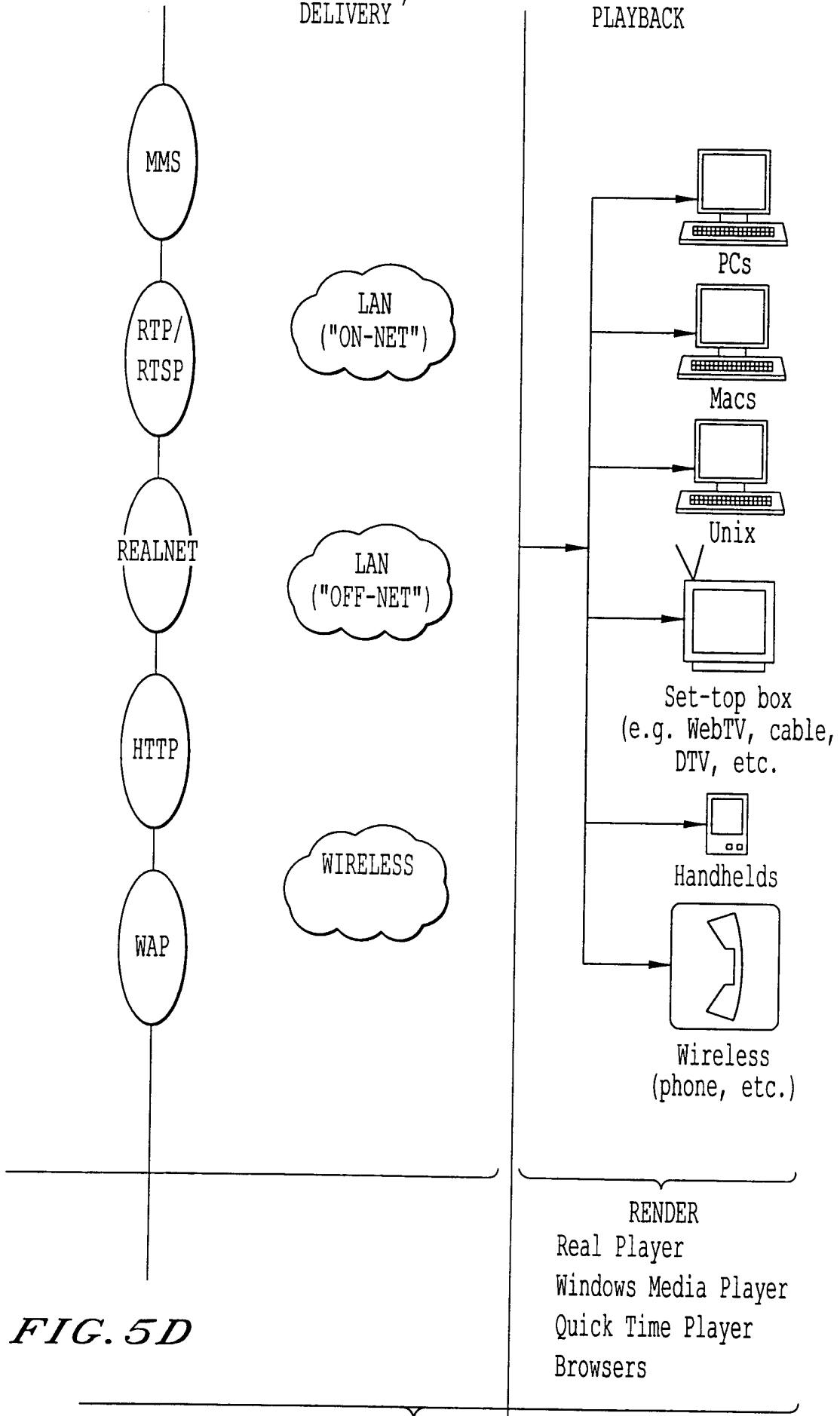

FIG. 5D

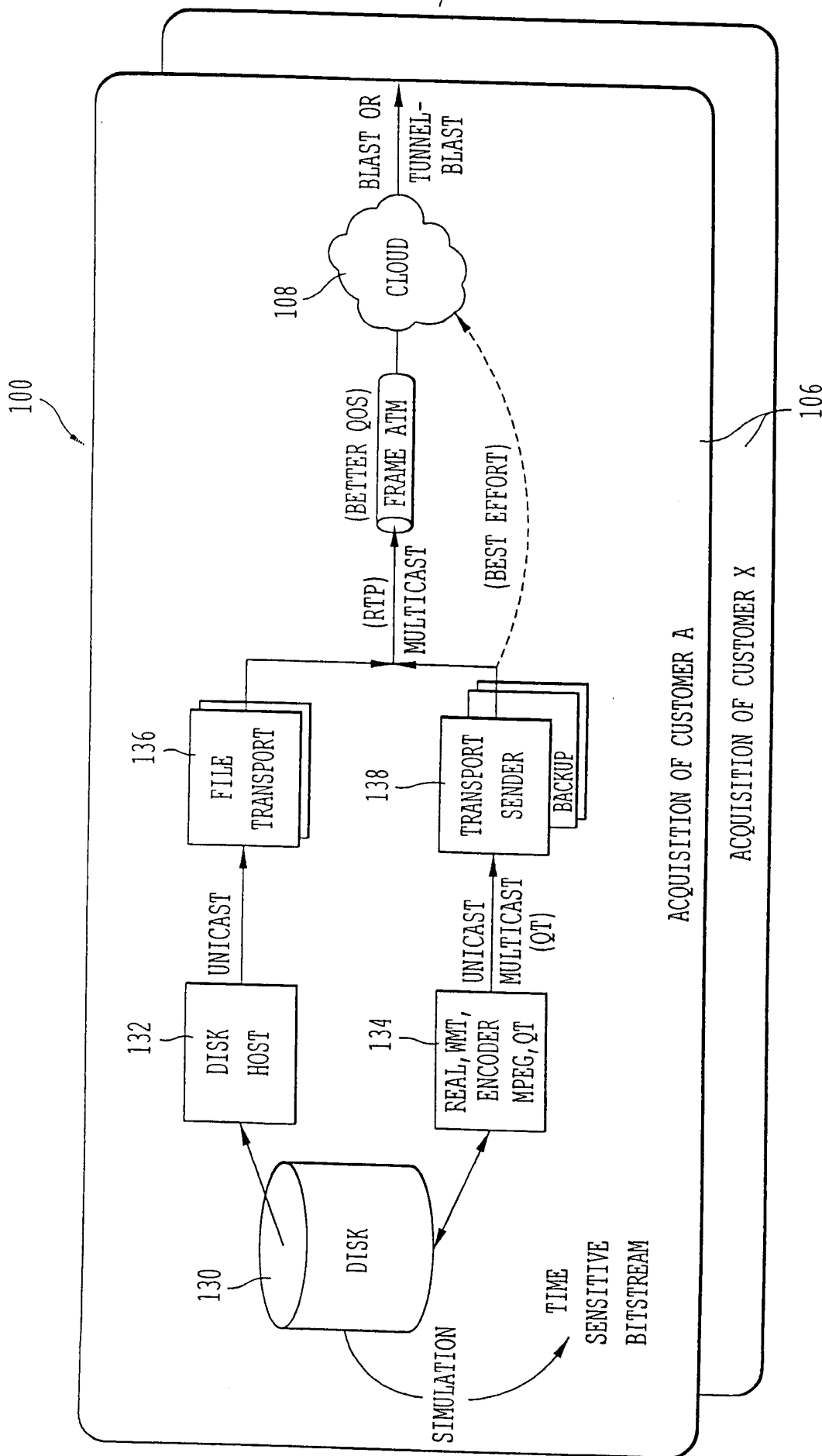

FIG. 6

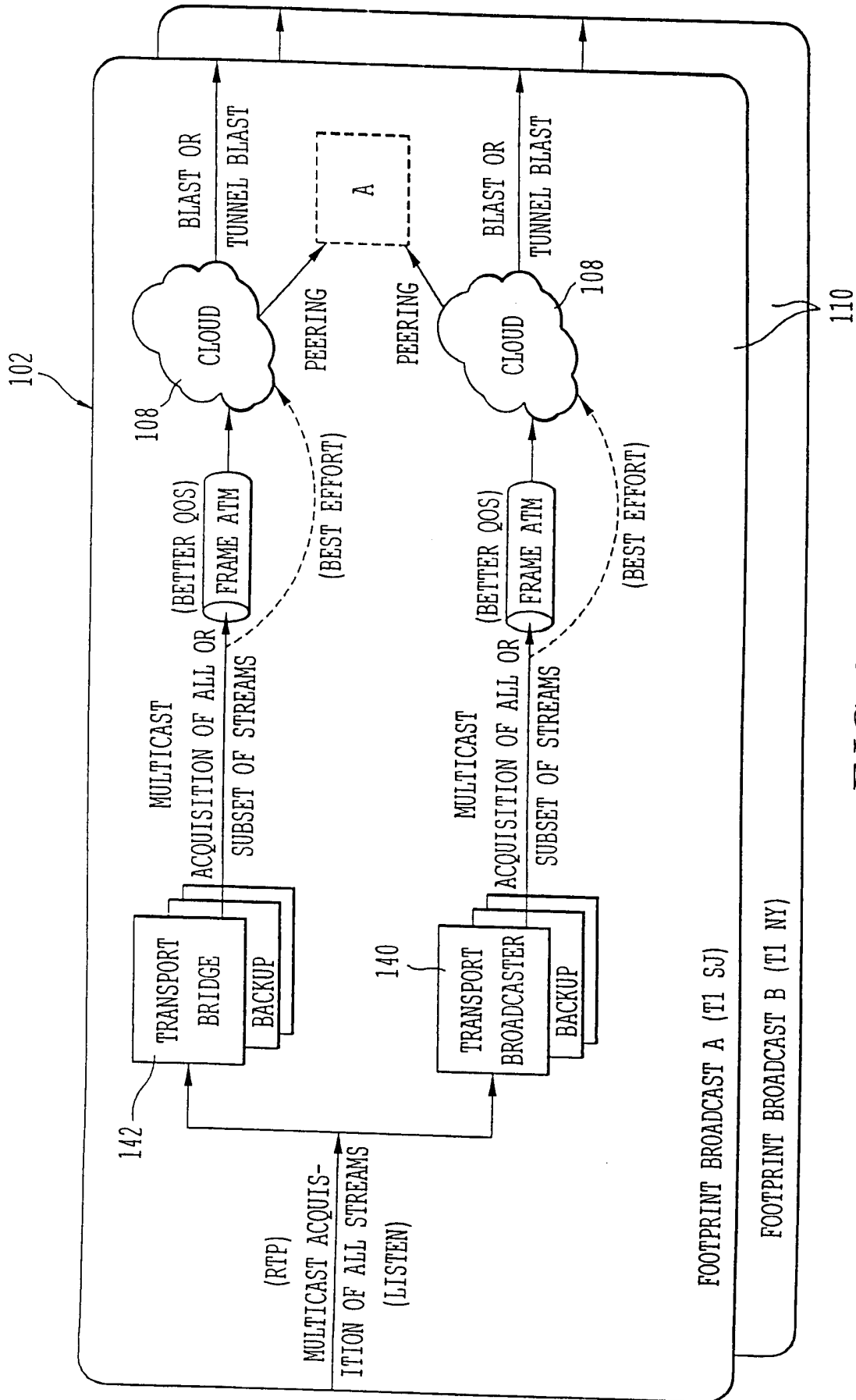

FIG. 7

11/14

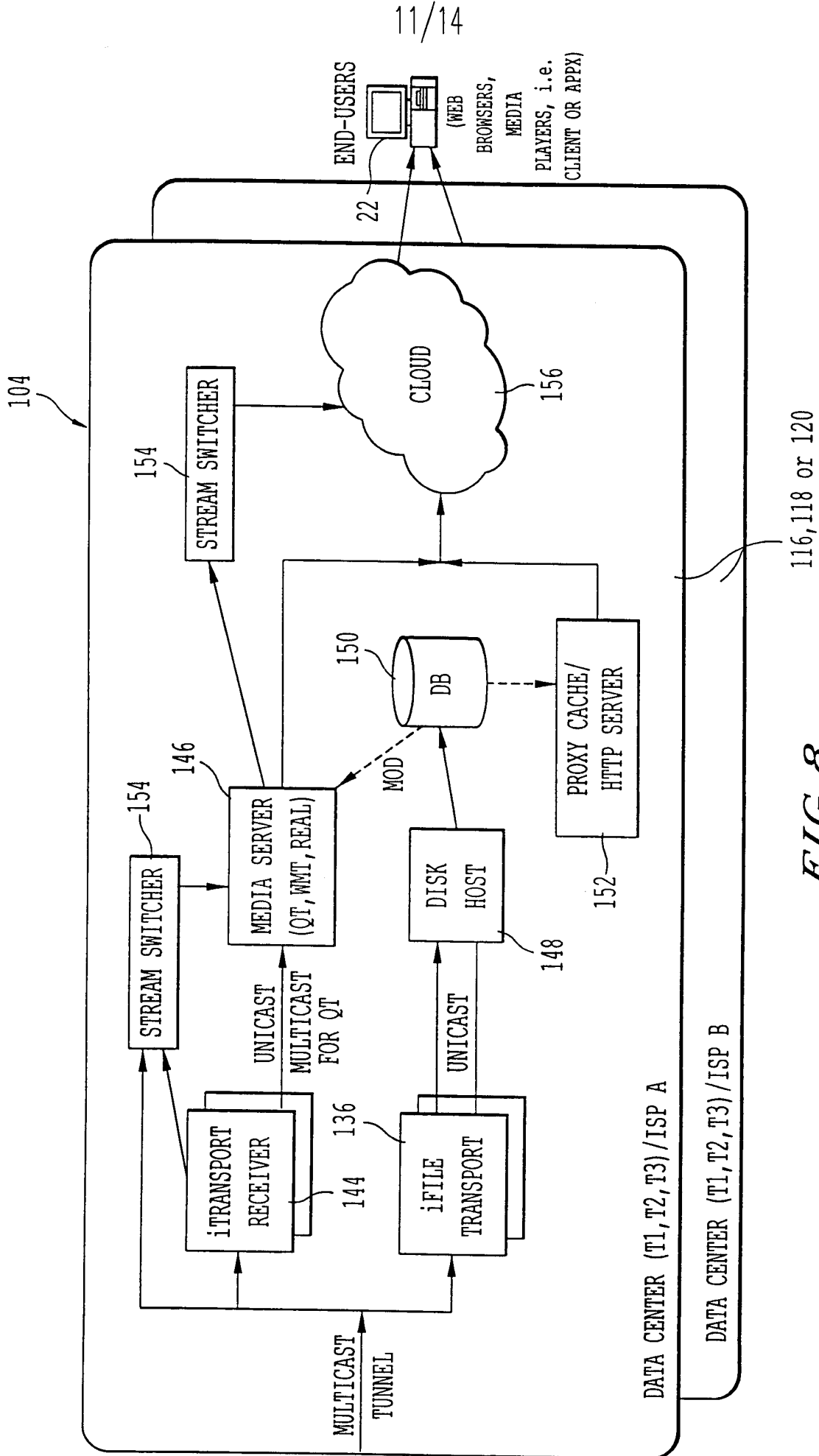

FIG. 8

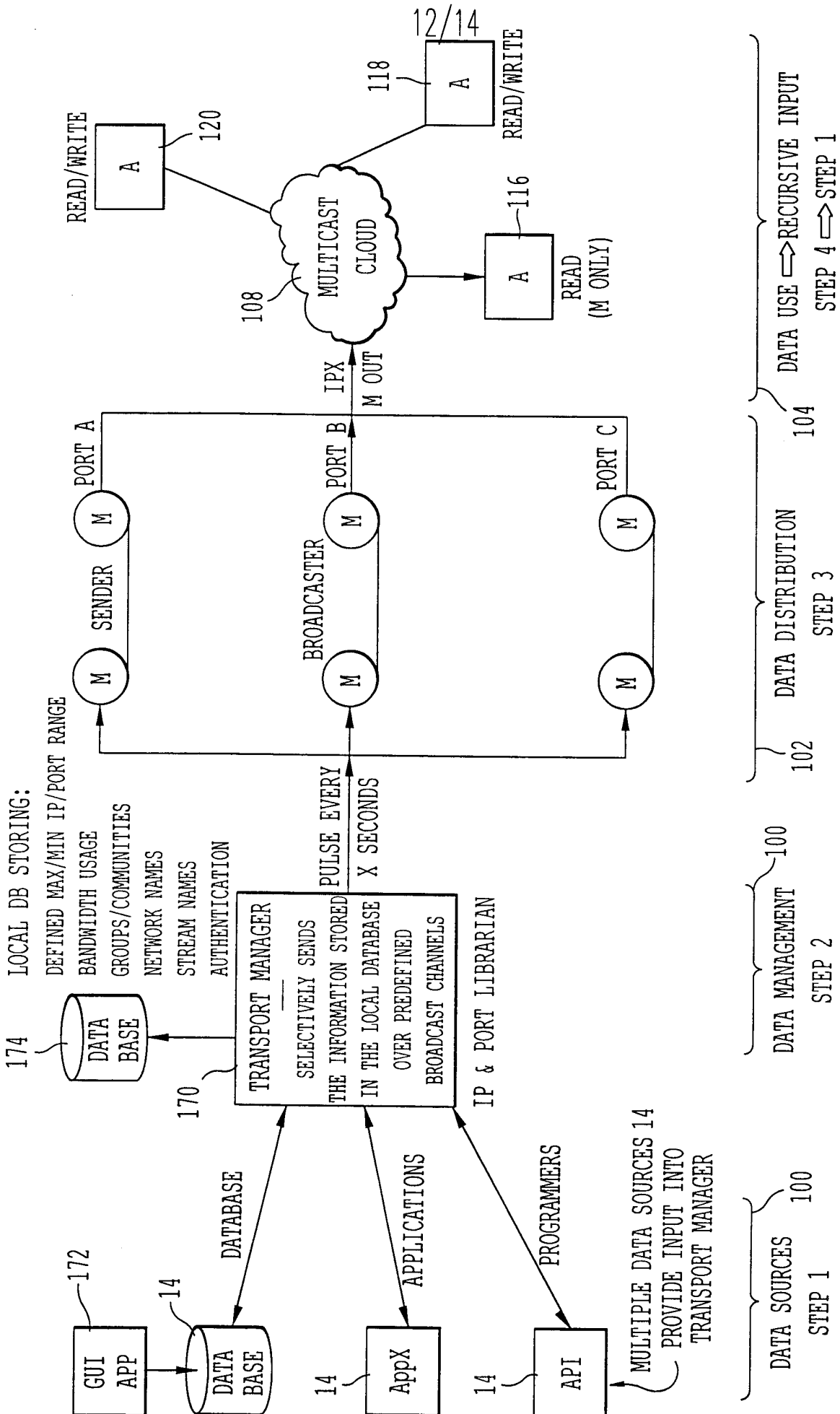

FIG. 9

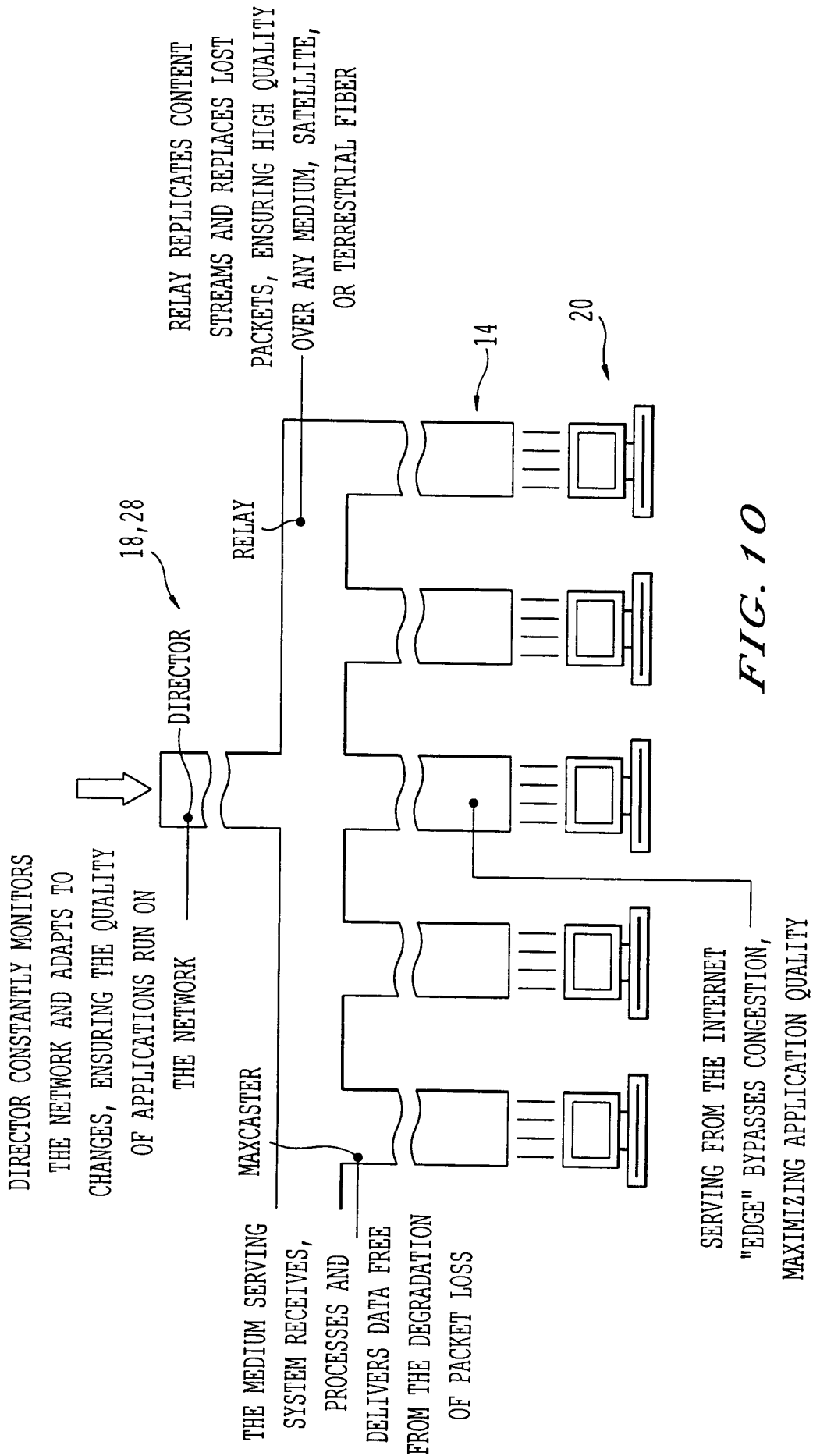

FIG. 10

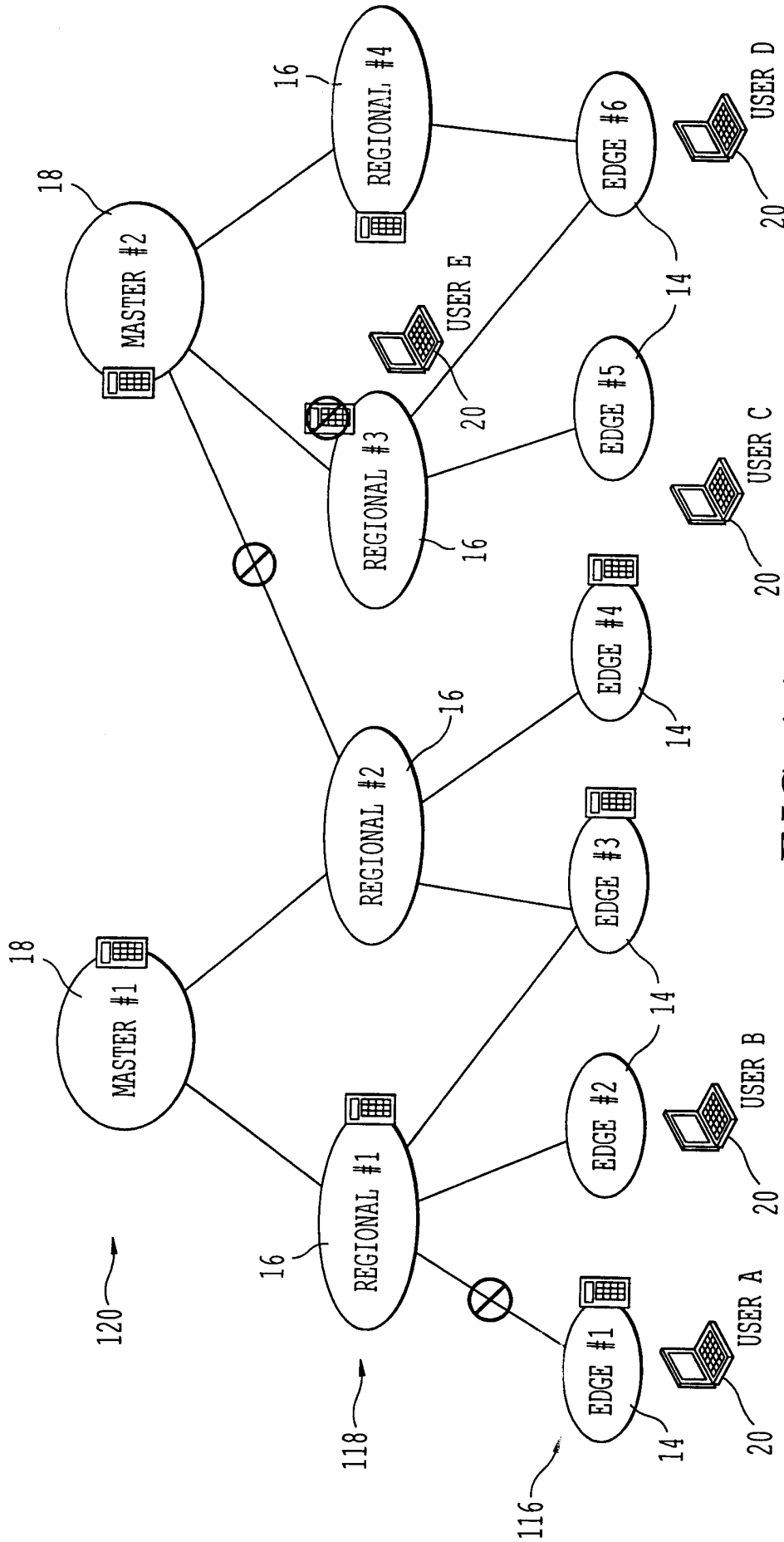

FIG. 11

INTERNATIONAL SEARCH REPORT

International application No.
PCT/US01/02881

A. CLASSIFICATION OF SUBJECT MATTER

IPC(7) : G06F 13/00, 13/14; H04N 7/14
US CL : 709/203, 219; 711/114

According to International Patent Classification (IPC) or to both national classification and IPC

B. FIELDS SEARCHED

Minimum documentation searched (classification system followed by classification symbols)

U.S. : 709/203, 219; 711/114

Documentation searched other than minimum documentation to the extent that such documents are included in the fields searched

Electronic data base consulted during the international search (name of data base and, where practicable, search terms used)

C. DOCUMENTS CONSIDERED TO BE RELEVANT

Category*	Citation of document, with indication, where appropriate, of the relevant passages	Relevant to claim No.
Y,E	US 6,195,680 A (GOLDSZMIDT) 27 February 2001, Abstract, col. 4, line 35- col. 17, line 36.	1-12
Y,P	US 6,178,480 B1 (TOBAGI et al.) 23 January 2001, col. 13, line 61-col. 22, line 16.	1-12
Y	US 6,014,694 A (AHARONI et al) 11 January 2000, in summary of the invention, col. 4, line 26-col.18, line 16.	1-12

Further documents are listed in the continuation of Box C. See patent family annex.

* Special categories of cited documents:	"T" later document published after the international filing date or priority date and not in conflict with the application but cited to understand the principle or theory underlying the invention
"A" document defining the general state of the art which is not considered to be of particular relevance	"X" document of particular relevance; the claimed invention cannot be considered novel or cannot be considered to involve an inventive step when the document is taken alone
"E" earlier document published on or after the international filing date	"Y" document of particular relevance; the claimed invention cannot be considered to involve an inventive step when the document is combined with one or more other such documents, such combination being obvious to a person skilled in the art
"L" document which may throw doubts on priority claim(s) or which is cited to establish the publication date of another citation or other special reason (as specified)	"&" document member of the same patent family
"O" document referring to an oral disclosure, use, exhibition or other means	
"P" document published prior to the international filing date but later than the priority date claimed	

Date of the actual completion of the international search 10 APRIL 2001	Date of mailing of the international search report 01 MAY 2001
Name and mailing address of the ISA/US Commissioner of Patents and Trademarks Box PCT Washington, D.C. 20231 Facsimile No. (703) 305-3230	Authorized officer Peggy Harrod GLENTON BURGESS Telephone No. (703) -305-4792