

[54] APPARATUS FOR PRINTING LABELS DIRECTLY ONTO PACKAGES, CONTAINERS AND THE LIKE

2,908,219 10/1959 Claus..... 101/44
 3,322,253 5/1967 Burns et al..... 197/1 R
 3,555,558 1/1971 Sherman..... 346/75
 3,708,050 1/1973 McCarthy, Jr..... 197/1 R

[75] Inventors: Erick L. Ahlgren; Arthur H. McMorris; Joseph L. Schweppe, all of Houston, Tex.

Primary Examiner—Clifford D. Crowder

[73] Assignee: Houston Engineering Research Corporation, Houston, Tex.

[57] ABSTRACT

[22] Filed: Apr. 19, 1973

An apparatus for placing labels on cartons, containers and bales which are subjected to having profile altering straps, bands, or framing members on the exterior. The apparatus includes a probe which finds the side of the carton and positions a probe relative to the surface. When a framing member or strap is found, the apparatus searches right and left and up and down to determine the availability of an area sufficiently large to print thereon and which thereafter prints a label directly on the surface by means of an ink applicator which label is located between the framing members or straps around the carton. A multiple head apparatus is incorporated to print on several sides of the carton.

[21] Appl. No.: 352,570

[52] U.S. Cl..... 101/35, 101/1, 197/1 R
 [51] Int. Cl..... B41f 17/24, G01d 15/18
 [58] Field of Search..... 346/75; 101/35, 41-44, 101/1; 197/1 R

[56] References Cited
 UNITED STATES PATENTS

2,134,041 10/1938 Hamm 101/122
 2,278,940 4/1942 Murphy..... 178/5.2 R
 2,656,240 10/1953 Hell 346/35
 2,819,671 1/1958 Porter, Jr. et al..... 101/44

19 Claims, 10 Drawing Figures

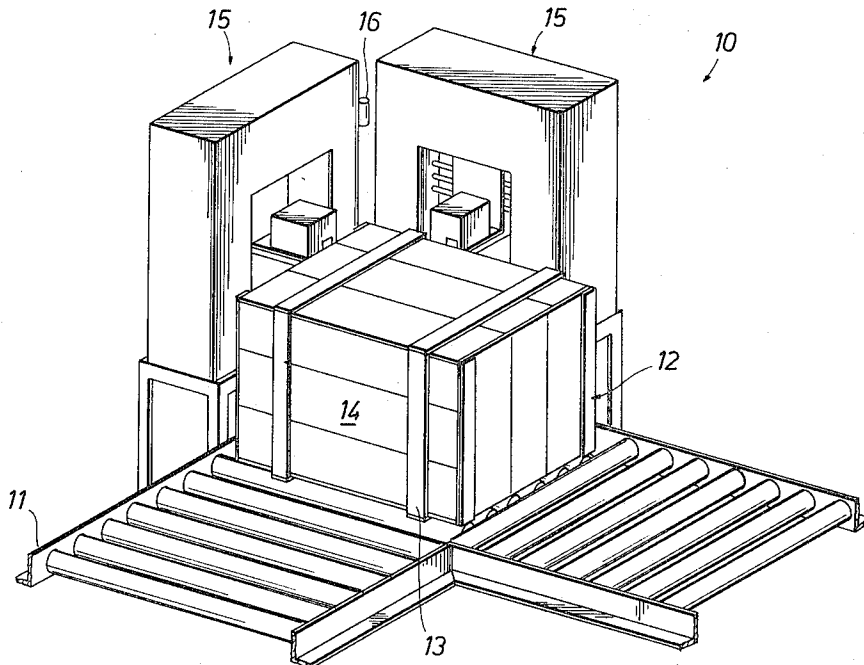

FIG. 1

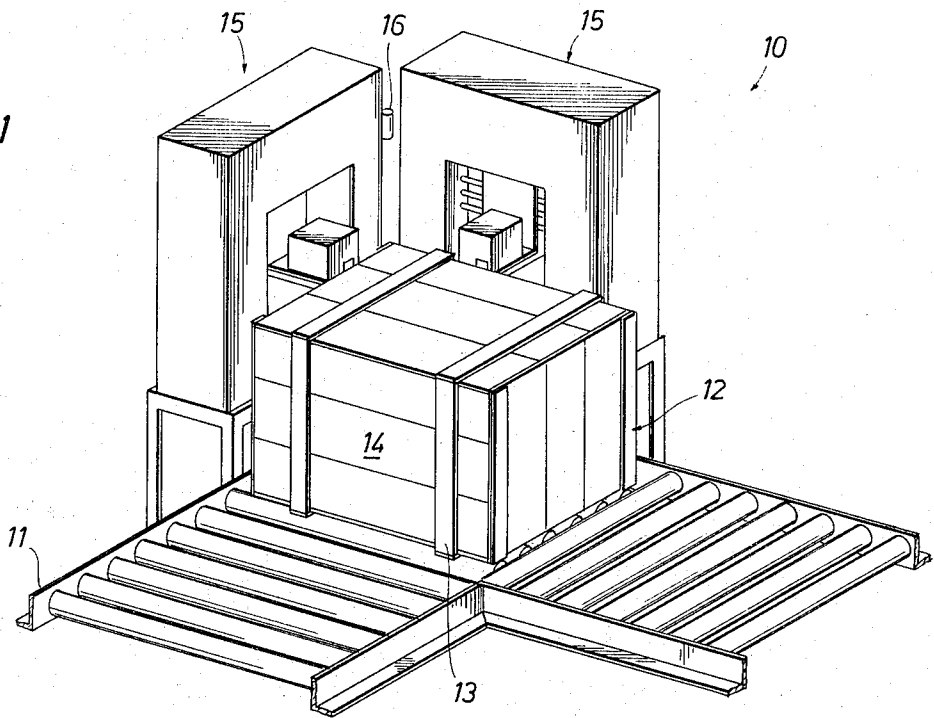
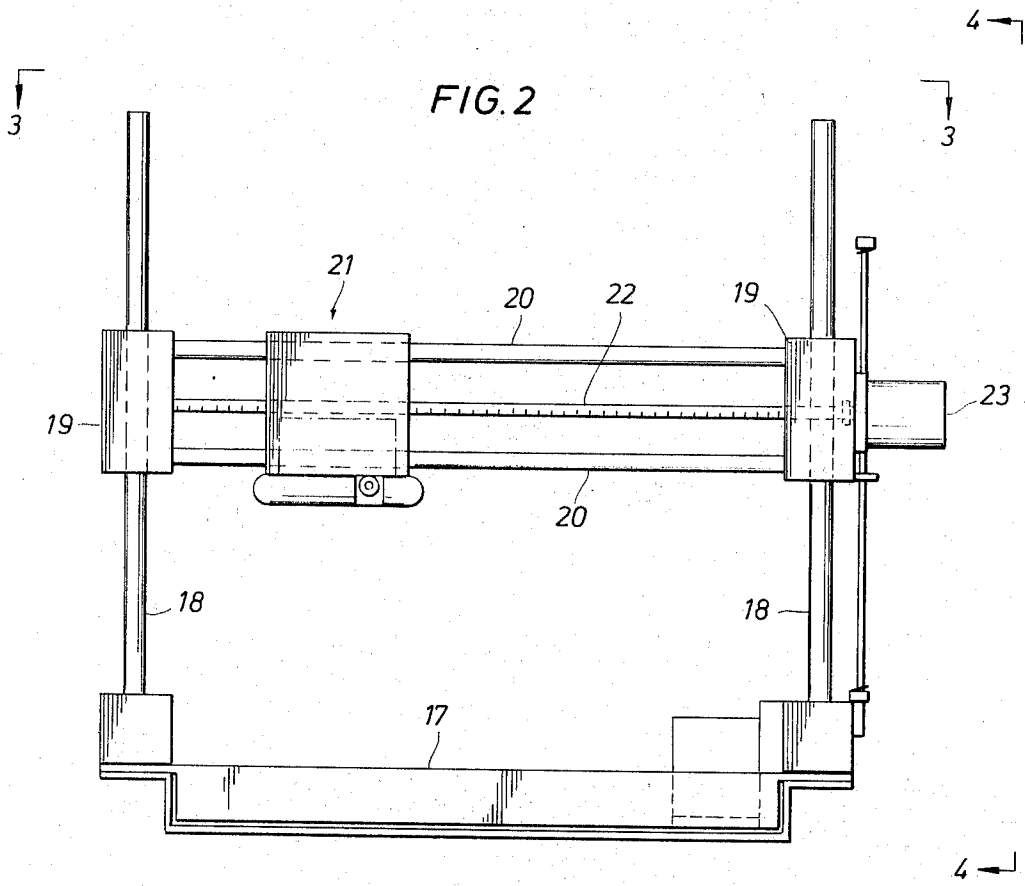
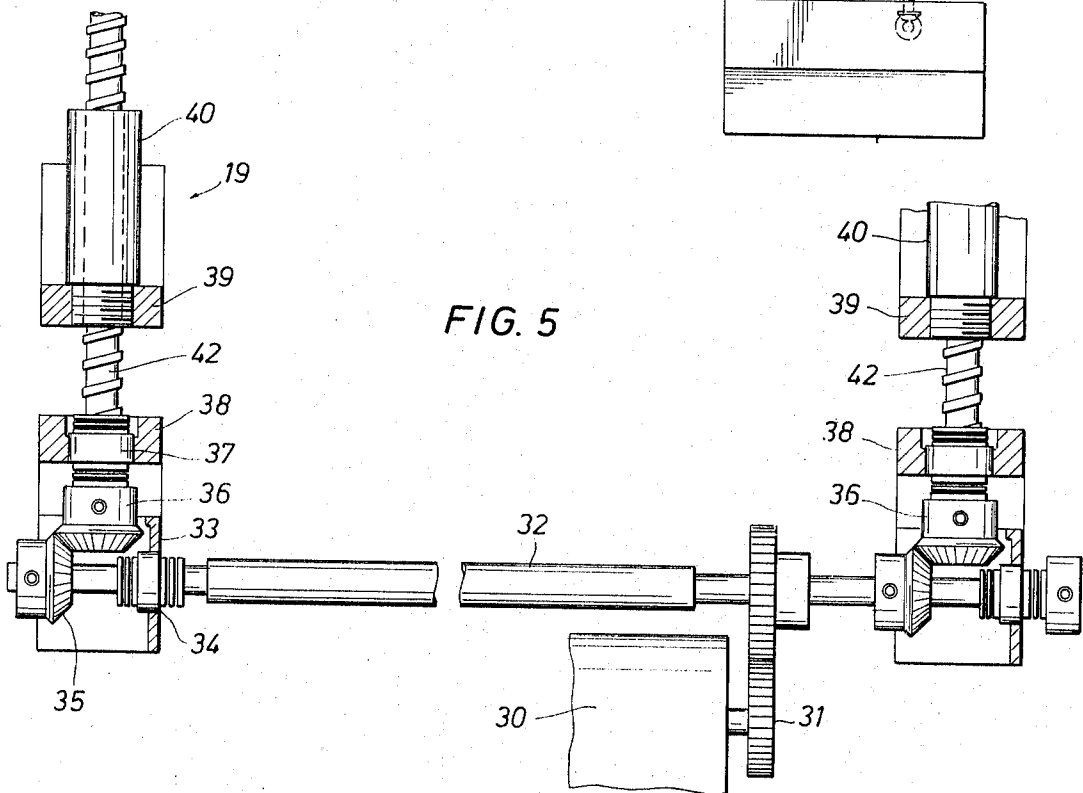
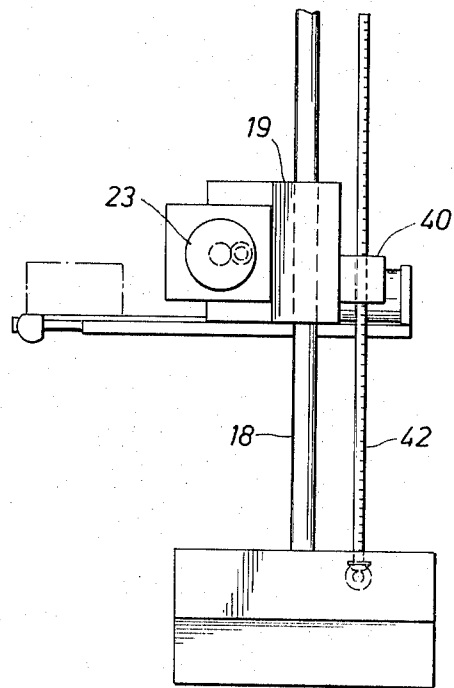
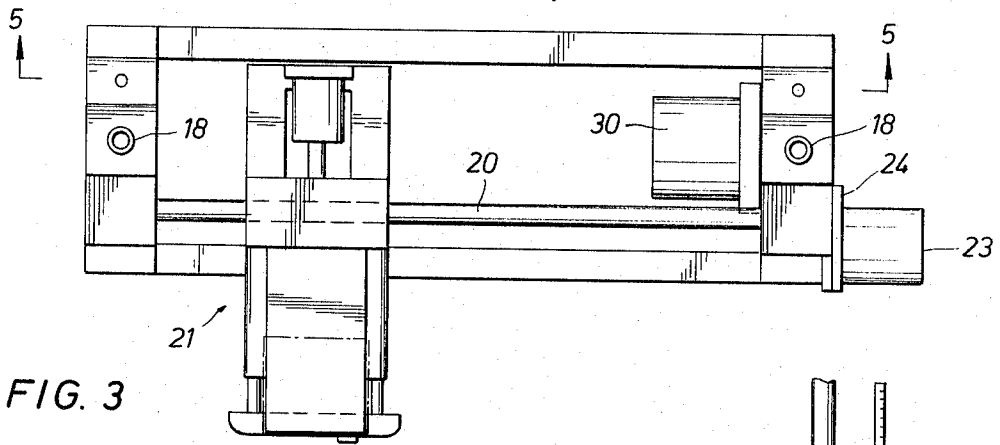

FIG. 2





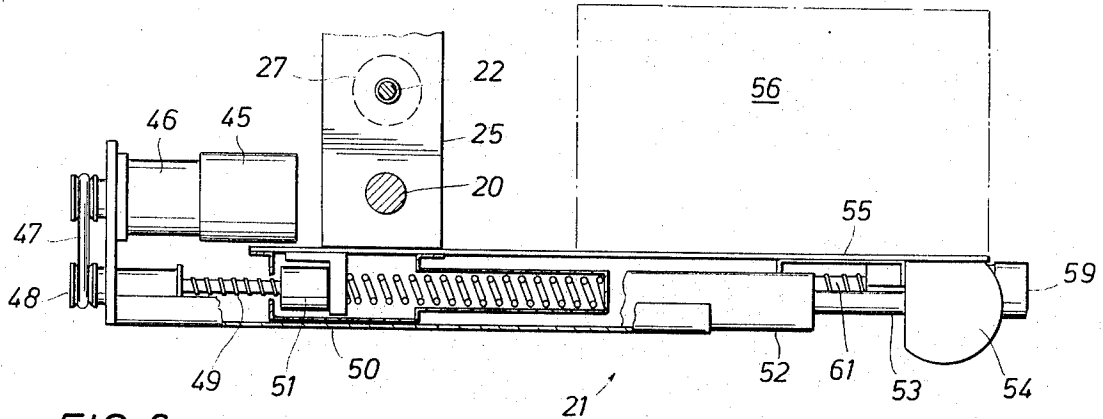

FIG. 6

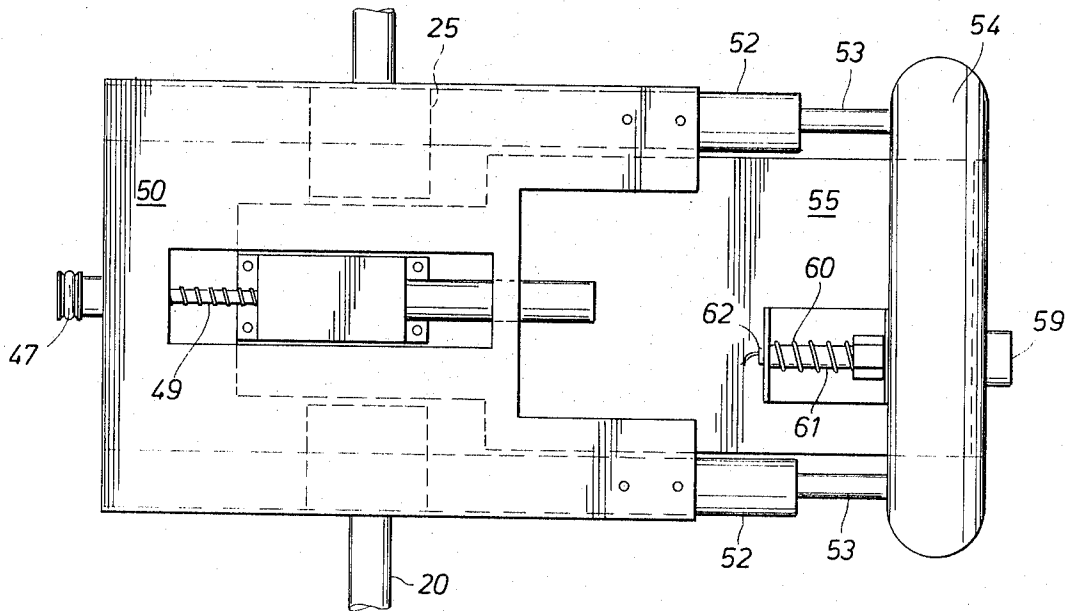

FIG. 7

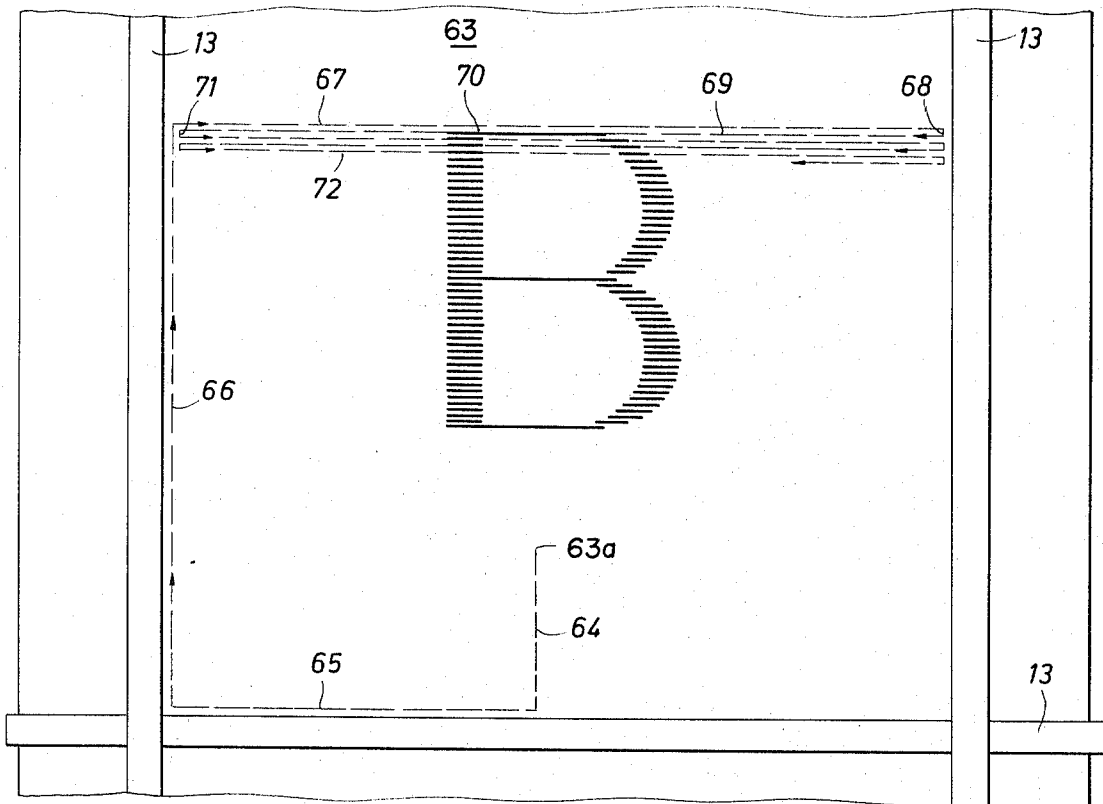

FIG. 8

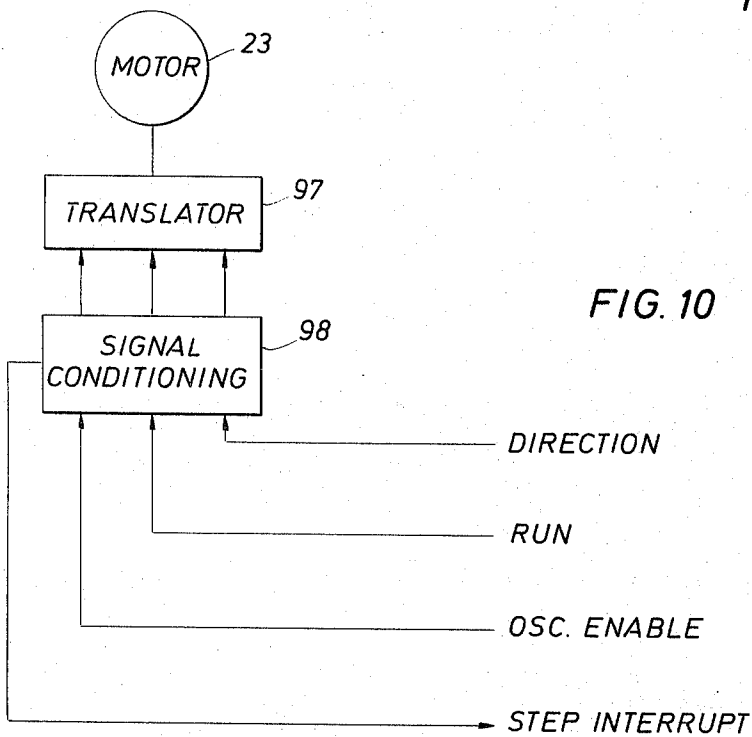

FIG. 10

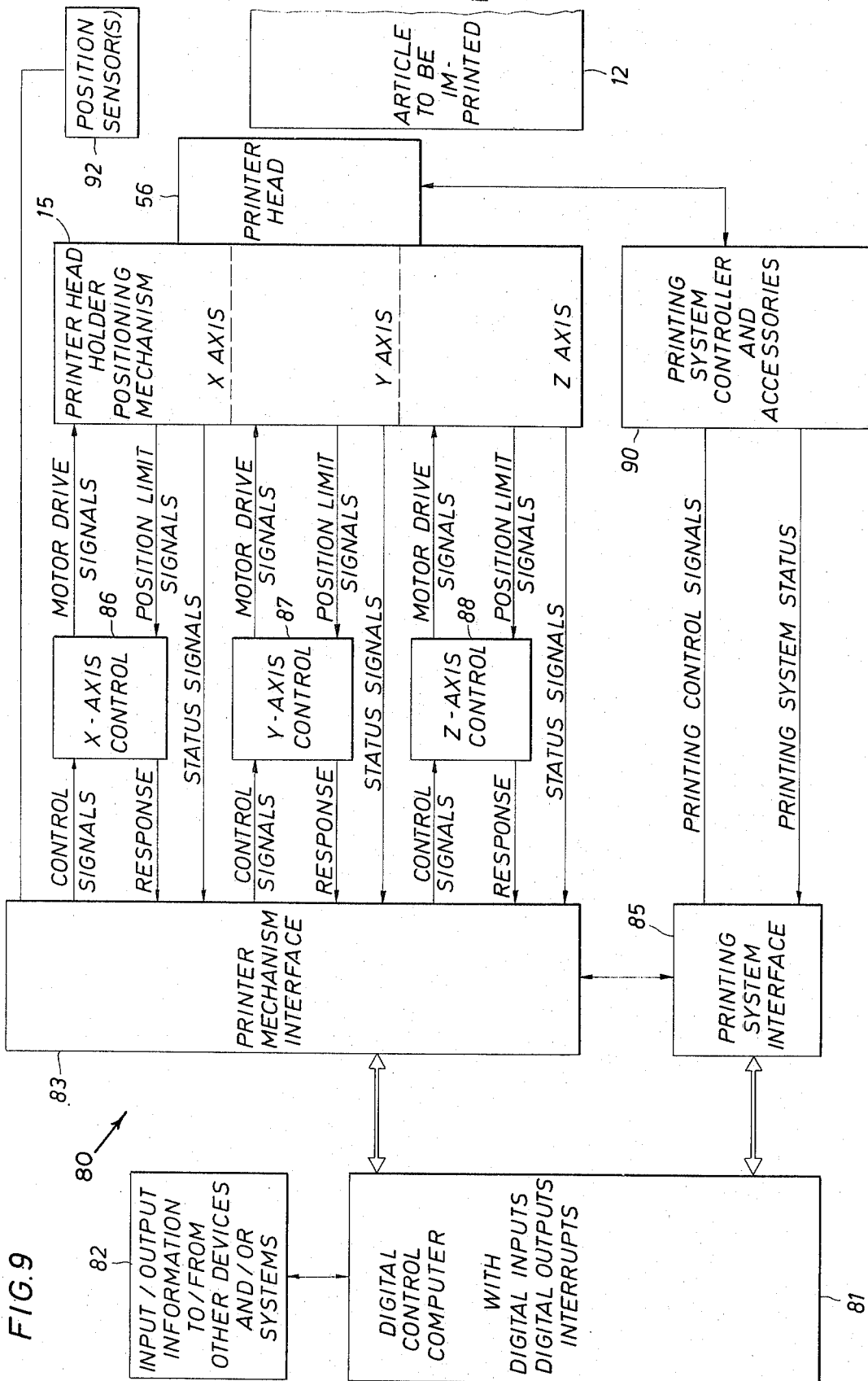

FIG. 9

APPARATUS FOR PRINTING LABELS DIRECTLY ONTO PACKAGES, CONTAINERS AND THE LIKE

BACKGROUND OF THE INVENTION

Many products from a variety of industrial, fiber and food plants are manufactured in bulk and are packaged for shipment to customers. Such packages take the form of bales with straps or bands in the same fashion as cotton bales. Another form of packaging often used includes a cardboard or thin wood container which is reinforced on the exterior by a number of bracing members of heavier stock. The straps, whether made of plastic or metal, form an indentation which distorts the profile. The external framing members protrude from the side and interrupt the smooth or planar surface. The packaged products require labels which may contain unique information regarding the package.

Heretofore, many labels have been made on detachable cloth or paper gummed labels which are applied in some fashion to the surface. Hand printing and attachment are costly and subject to error. If they are placed over an external framing member or a strap, the change in profile distorts the label and its attachment is less certain.

With a view of placing labels directly on the surface of the crate, carton, or bale the present apparatus is able to locate a generally planar surface on the bale which is sufficiently large to receive the label. The label is printed directly on the surface to avoid the problem of transfer of adhesive labels and the like. The apparatus is therefore capable of imprinting a label containing information unique to a specific package, bale, carton or container at a generally designated location on the item. It is further able to position a printer head by movement in three orthogonal directions under command of a digital control computer where basic information about the package is supplied and imprinted.

One object of the present invention is to provide a sensing mechanism which locates the package, bale, carton, container or the like and positions the printer head at a beginning point selected so that the label will be located on a generally smooth planar surface.

Another object of the present invention is to provide a sensing mechanism which locates steel bands which have been placed around a package or bale so that printing on the steel bands can be avoided. The ability to move in three dimensions enables the print head to follow the print surface even though that surface is not perfectly planar and is not exactly parallel with the plane of the printer mechanism. In other words, the printer mechanism can follow the surface whether it is planar, slightly contoured or not perfectly aligned.

SUMMARY OF THE PRESENT INVENTION

The present invention includes a print head which is carried on an XYZ system capable of movement along an orthogonal axes. It is preferably adapted to be positioned adjacent to a conveyor or other path where packages or cartons travel. The package or carton is weighed or other information is provided as an input to a storage device. The storage device is scanned by a digital control computer which reads the input information such as weight, destination, consignee and the like. The digital control computer formats the information. It is formatted to fall within a surface area of a specified range. The carton is curbed and the print head is positioned above a probe which locates the

sidewall of the carton. The probe extends outwardly until the carton is engaged. It then moves horizontally and vertically to find a generally smooth portion of the facing surface on which the label can be imprinted. It particularly locates external frame members or bands which distort the planar surface. Once an area of sufficient size has been located, the print head is positioned at a beginning point and scans across the designated area printing directly onto the carton. Thereafter, the probe which locates the surface and the print head are withdrawn and the carton can move on. One embodiment discloses two print head mechanisms which are arranged at 90° to print on different faces of a generally rectangular carton. Additional print heads can be used.

BRIEF DESCRIPTION OF THE DRAWINGS

FIG. 1 is a perspective view showing a dual head labeled printing mechanism installed at right angles relative to a conveyor for printing on two faces of a container or carton;

FIG. 2 is an elevation view of one print head which is mounted for movement in orthogonal directions;

FIG. 3 is a view taken along the line 3 — 3 of FIG. 2 showing a plan view of print head carrier and associated apparatus;

FIG. 4 is a view taken along the line 4 — 4 of FIG. 2 showing the apparatus of FIG. 3 in side view;

FIG. 5 is a sectional view taken along the line 5 — 5 of FIG. 3 and further including internal details of construction;

FIG. 6 is a side view, partly in section, of the print head mechanism and apparatus which extends it toward a carton for imprinting;

FIG. 7 is a bottom view of the apparatus shown in FIG. 6;

FIG. 8 shows a path of the print head on a typical bale; and

FIG. 9 is a schematic block diagram of the electronic apparatus associated with the direct label printing apparatus; and,

FIG. 10 is a schematic of one motor and the drive circuit for its operation.

DESCRIPTION OF THE PREFERRED EMBODIMENTS

Attention is first directed to FIG. 1 of the drawings where the present invention is indicated by the numeral 10. It is installed adjacent to a conveyor 11. The conveyor 11 transfers a container or carton 12. The carton 12 has external framing members 13 on it. They interrupt the integrity of the generally planar sides and prevent the application of a label at a random position on a side. Rather, a clear space must be located by the present invention which then works with the clear space left between the bands. The clear space on which the label ought to be printed is indicated generally by the numeral 14, it being understood that the face where the printing actually will occur is facing the apparatus 10. The significant point is that the area 14 is generally between the frame members 13 which destroy the generally smooth profile.

The carton 12 may be formed with steel or plastic bands. They wrap tightly around the cardboard or canvas covered bulk shipment and hold the contents in. They function differently in that they distort the profile in a manner differently from the framing member shown but the net result is the same.

A third type of container includes those which are generally rectangular, having no straps or framing members, leaving generally planar sides which are usually perpendicular to another.

In FIG. 1, the numeral 15 identifies a print head assembly which is duplicated at two locations which are preferably at right angles to one another for printing on right angle faces of the container 12. Only one may be required in many circumstances and to this end, one of the two can be omitted. On the other hand, three or more print heads may be included. Inasmuch as they are identical in construction and operate in the same manner, it is believed that a description of only print head assembly 15 will suffice.

The carton 12 travels the conveyor 11 and is curbed or cornered to be brought into near proximity to the present invention. By way of example, a single print head assembly can be positioned adjacent to the side of a conveyor and a set of converging curbs can be used to align the carton. In the arrangement shown in FIG. 1, it can be cornered by the high edge plates adjacent to the conveyor system, then imprinted and thereafter permitted to travel the remainder of the conveyor system. In any case, it is only necessary that the carton or container be brought in the near proximity and its presence detected. For this purpose, a photocell 16 positioned at a point above the container 12 responds to the interruption of light from a light source below the container and below the conveyor to indicate near proximity of the container. When the photocell 16 forms a signal, the labeling equipment 10 begins operation.

The print head assembly 15 is shown better in FIG. 2. The surrounding structural housings has been omitted for sake of clarity. In FIG. 2, a supportive framework 17 extends across the bottom of the equipment and supports an upstanding pair of columns 18. The columns 18 are identical and to this end, a description of one will suffice for the other. The two columns 18 each support similar apparatus. The columns are, in fact, parallel to long screws having a helix or thread extending their full length. Each column 18 supports and aligns a travelling nut assembly at 19. Again, the travelling nut assembly is duplicated at both sides of the apparatus.

The travelling nut assembly 19 is guided by the support column 18. The travelling nut has a span or length which is defined by an external housing. The housing supports a pair of smooth, parallel horizontal guide bars 20. The guide bars 20 span the horizontal distance between the travelling nut assemblies 19. They are preferably spaced apart. The guide bars or rods 20 support a carriage generally indicated at 21 which will be described in greater detail hereinafter. A lead screw 22 is parallel to the guide bars 20 and positioned between them. The lead screw extends to the right hand travelling nut assembly 19 as shown in FIG. 2 and is operatively connected with a drive motor 23. The drive motor 23 is geared down by an appropriate gear box or belt and pulley mechanism. It rotates the lead screw 22.

Attention is momentarily directed to FIG. 3 where the motor 23 is shown to the side of the travelling nut assembly 19. It is supported by an appropriate bracket 24. The guide rods 20 and the lead screw 22 are arranged vertically one above the other.

Going now to FIG. 6, the numeral 25 identifies an upright frame member of the carriage 21 which spans the

three parallel members 20 and 22. It supports a travelling nut 27 which is engaged with threads on the lead screw 22 so that rotation of the lead screw moves the travelling carriage 21 to the right or left. Returning now to FIG. 2 of the drawings, the operation of the equipment will be described in so far as it relates to travel to the right and left as viewed in FIG. 2 or movement along the X-axis. The carriage 21 is guided by the guide bars 20. The motor 23 through an appropriate gear box rotates the shaft 22. The threaded shaft engages the travelling nut 27 which is built into the carriage 21. Rotation in one direction advances the carriage 21 to the right and rotation in the opposite direction advances it to the left. The range of movement is of course limited by the travelling nut assembly 19 which is supported on the upright columns 18 as viewed in FIG. 2. In other words, the carriage 21 can move to and fro limited by the width of the apparatus.

The foregoing is directed to the mechanics of movement in the X-direction. For movement in the X-direction, it will be observed that a single lead screw and single travelling nut is used. Of course, alignment of the equipment is maintained by the use of the parallel guide rods 20. The vertical dimension in FIG. 2 will then be defined as the Y-direction. Movement in the Y-direction is guided by the columns 18. This advances all of the X-axis apparatus as a unit. For a better understanding of operation of this equipment, attention is momentarily directed to FIG. 5 of the drawings. The numeral 30 identifies the Y-axis drive motor. It is connected through appropriate gears at 31 and then to a drive shaft 32 which spans the apparatus. The drive shaft 32 at its left hand end extends to a fixed housing 33. A bushing 34 supports the shaft 32 in the housing. A bevel gear 35 is placed on the shaft 32 and engages a mating bevel gear 36. The bevel gear 36 is supported adjacent to the shaft 32 and the other gear 35 by means of a bushing 37 which bushing rests in a wall 38 of the housing 33. The gear 36 is locked to an upright shaft 42 which of course is a lead screw. The travelling nut assembly 19 includes a structural portion 39 which enables the travelling nut to be connected with the guide bars 20 and a generally tubular housing 40 which contains the travelling nut assembly itself.

On the right hand side of FIG. 5, similar apparatus is likewise incorporated. It is arranged somewhat differently in that the bevel gear is located on the left rather than on the right. However, the remainder of the apparatus is the same in construction and arrangement.

The structure of FIG. 5 enables the motor 30 to rotate the shaft 32 which then rotates the lead screws 42. The lead screws rotate in a common hand or direction. The travelling nuts 19 supported on the lead screws are not free to rotate but rather traverse the length of the lead screws because of the structural interconnection between the travelling nuts assemblies 19 as illustrated in FIG. 2. Thus, motion in the Y direction is accomplished under the urging of the motor 30.

The travelling nuts mentioned to this juncture are preferably ball nut drive mechanisms manufactured and supplied by Thomson Industries, Inc. The motors are preferably manufactured by the Superior Manufacturing Company of Connecticut and sold under the trademark "Slo-syn." The motors step 1.8°, or 200 steps per revolution. The driving circuit is also supplied by the same source.

Attention is directed to FIG. 4 of the drawings where the numeral 42 identifies the vertical lead screw which is spaced to the rear of and parallel to the guide post 18. As shown in FIG. 4, the travelling nut 40 is engaged with the lead screw 42. Rotation of the screw 42 imparts upward or downward movement to the travelling nut 40 and hence to the assembly 19 which is attached to it. The same apparatus is duplicated on both sides of the equipment so that the X-axis apparatus previously described moves upwardly and downwardly in the Y-direction.

Attention is next directed to FIG. 6 and FIG. 7 which show the print head carriage 21. As will be recalled, it has an upstanding bracket 25 which engages the guide bars 20 and the horizontal lead screw 22. This maintains the equipment generally horizontal without regard to movement along the X or Y-axes. The apparatus shown in FIG. 6 and 7 jointly includes a drive motor 45 connected to a gear box 46 for driving a belt 47 which connects to a pulley 48 and rotates a shaft 49. The shaft 49 is just above a fixed bottom plate 50 which is fixed to the upstanding bracket 25. The lead screw 49 engages a travelling nut 51 which travels forwardly and rearwardly in the Z-direction upon rotation of the screw 49. As shown better in FIG. 7, the numeral 50 identifies the fixed portion of the bottom which does not move in the Z-direction. The fixed portion includes a fixed cylinder 52 located along both edges. A slidable rod 53 extends into and out of the cylinder 52. The cylinder 52 serves as a guide for the rod 53 which reciprocates. This is duplicated at both sides of the apparatus. The rod 53 extends outwardly to a bumper 54. The bumper 54 supports a mounting plate 55 on the top side. The mounting plate is adapted to receive an ink printer 56. More will be noted concerning the printer hereinafter.

Returning now to FIG. 7, the bumper 54 carries a projecting probe 59. The probe 59 is also movable along the Z-axis. It is spring loaded by a spring 60 mounted around a shaft 61 for purposes of guidance. A switch 62 responds to the force of the spring 60. The switch forms signals which drive the motor 45. The switch 62 is off when the spring force is in a specified range. When the force is outside the range, the motor is driven to move the probe in a direction to alter the spring force to the desired range. When the force is in the specified range, the print head is in an operable range of the surface on which it prints. When the range is incorrect, the printing may be distorted.

The motor 45 advances the printer 56 along the Z-axis in the following manner. The motor drives the shaft 49 which rotates causing the travelling nut 51 to be advanced or retracted. Movement of the travelling nut 51 is coupled to the mounting plate 55. The plate 55 moves forwardly and backwardly guided by the rods 53 which prevent canting of the plate 55. The apparatus advances until the probe 59 touches the surface of the carton. The probe 59 is pushed inwardly, compressing the spring. When the spring is compressed to a specified force, a signal is formed by the switch 62. The signal is supplied, interrupting operation of the motor 45. The switch 62 thus responds to pressure applied by the spring. It operates the motor 45 when the probe 59 is not touching anything or when the spring is excessively compressed. In other words, the spring 60 tolerates a range of variation in which the motor 45 is not operated at all. However, pressure in the spring 60

which is too small or too great initiates operation of the motor 45. From this description, it will be understood how the apparatus has a range of tolerance for slight variations in the surface on which the label is to be printed.

The probe 59 thus senses the presence of the surface on which the label is to be printed. It positions the printer 56 at a location where the surface is neither too close or too far. The probe 59 thus responds to either the contour in the case of a wooden crate or to the presence of steel bands, in the case of band wrapped cartons to determine the location of the obstacles of printing. For detection of steel bands, the probe preferably incorporates a ferrous material sensitive head. The head forms a signal when a steel band is encountered. In the detection of wooden framing members about a crate as exemplified in FIG. 1, it forms an indication of an encounter with an external framing member when it is unable to traverse any further, indicating that it has abutted against the edge of a framing member. In that instance, the profile is indicated by a fairly abrupt change in surface, so abrupt that the probe is unable to move over the change in surface. The surface change may not be so extreme and will be detected in the instance of a profile change where a plastic band is used by observing the derivative of the motor driving signal.

Attention is next directed to FIG. 8 of the drawings which illustrates the container or carton 12 and shows how a single letter will be painted on the exterior. The carton or container 12 is preferably of wooden construction for purposes of this example, although it should be understood that such carton may be formed from numerous other known materials. A band, strap or external frame member 13 is formed about carton 12 for structural reinforcement. In the example, three framing members are included, two being vertical and the third being horizontal and somewhat near the bottom. Once the carton 12 is sensed in near proximity of the equipment, the probe 59 is slewed to a programmed XY position. Along the Z-axis, the carriage 21 is retracted. Once it is slewed to a specified XY position which is indicated by the numeral 63a in FIG. 8, it begins to search for the frame members 13 which determine the writing field. For purposes of definition, the numeral 63 identifies the writing field which must be spaced between the frame members. The writing field must typically equal or exceed a specified minimum. For instance, suppose that the weight and destination are to be painted on the carton or container 12. This may require a specified surface area such as 4 inches in vertical height and 10 inches horizontally. Of course, these dimensions are specified and the apparatus then searches for an area or writing field 63 which equals or exceeds these dimensions.

The apparatus is programmed to a beginning point 61 which will be assumed to be in the writing field, or between the frame members 13, and not to the side where it may be impossible to obtain sufficient space to write on the crate 12. In any event, the apparatus is slewed to the beginning point 63a. At this juncture, a choice can be made whether the apparatus will search horizontally vertically, or in combination. For simplicity sake, the numeral 64 identifies the route which the probe follows where a vertical search is first begun. If there is only one horizontal framing member, it is wise to locate it and to this end, the vertical search is begun from the beginning point, and the probe moves down-

wardly along the path 64. When it encounters the frame member 13, the probe then travels along the path 65 adjacent to the frame member until a vertical frame member is encountered. It then travels upwardly along the indicated path 66 until adequate vertical clearance is measured. Again, this is a dimension which is specified in the beginning. At this juncture, two sides have been located. The remaining question is whether or not the horizontal clearance is adequate. The apparatus then travels along the path 67 to measure the horizontal clearance. This too will then be tested to determine if it is adequate. In some instances, it will not be necessary to measure along the path 67 because it is known that the vertical framing members are more than a sufficient distance apart to enable the label to be placed on the carton. For instance, the distance might exceed by three or four fold the maximum width of the label. In that event, there is not need to seek out the right hand framing member 13 because more than adequate clearance is available. However, assuming the worst case, the path 67 shows the route which the probe travels to find the right hand frame member. Once it has been found, the distance of the path 67 is measured and if adequate, the label can be printed.

The numeral 56 in FIG. 6 identifies the printer apparatus. It is preferably a bought item manufactured by the A. B. Dick Company and sold under the trademark "Videojet." It is an apparatus which has a small orifice which sprays a procession of droplets of ink across a charged plate and the droplets of ink form a character or impression shaped by control circuits in the apparatus. The apparatus is used in the following manner. The numeral 68 identifies a slight downward step and the apparatus then begins a scanning mode or movement along the path or scan 69. The path 69 is the first writing path. The Videojet equipment is operated in a manner such that no ink is applied to the crate 12 except when a character is to be printed. Characters, however, are not printed individually, rather, an entire line of characters is scanned in horizontal motions and ink is applied so that several scans will write an entire line. The scan 69 is the first one where ink is applied.

For purposes of explanation, the letter B is shown in FIG. 8. The scan 69 moves along the top edge of the letter B and applies ink at 70 which is a portion of the top of the letter B and applies ink at 70 which is a portion of the top of the letter. The scan 69 moves all the way to the left and the device then indexes downwardly again along the path indicated at 71. The downward movements at 68 and 71 are of necessity fairly short. It then enables the equipment to form a subsequent scan along the path indicated at 72. Again, no ink is applied except when the equipment is so commanded and ink is then applied to continue building up the character as illustrated in FIG. 8. The scans which move horizontally alternate in direction. There is no need to return the apparatus from the right hand end of each scan to the left before beginning another operation. In other words, the return trip itself is, in fact, a scanning operation.

Horizontal scanning to and fro is continued proceeding from the top of the labeled area 63a to the bottom. The print field 63a is then imprinted with the appropriate label. When the last ink has been applied, the equipment can be retracted. That is, the printer 56 is retracted along the Z-axis to a withdrawn position.

During actual printing, the probe 59 is in contact with the surface. It is able to accommodate small variations in profile. This is accommodated at the spring 60. Moreover, the motor 45 can be operated to slightly advance or retract the printer 56. This will enable it to write over a rough surface. The probe will be observed to be in contact with the print field 63a at a point somewhat below the place where the ink is actually applied. It is preferable to write from top to bottom so that ink previously applied is not smeared by the probe. The vertical gradation in print is subject to variation depending on how large the print is to be. The coarseness or fineness thereof and other scale factors. To this end, the incremental downward steps 68 and 71 are preferably specified so that the fineness or degradation in the print meets some standard.

Attention is next directed to FIG. 9 of the drawings which is schematic block diagram of the electronics included with the apparatus. It is generally indicated by the numeral 80. The numeral 81 identifies a digital control computer where information to be printed is input from a source 82. This is subject to variation of worldwide range. It may typically include weight and destination. It is formatted and appropriate scale factors applied. The data from the computer 81 is next supplied to a printing system interface 85. This printing system interface equipment 85 is equipment which is supplied with the Video Jet printing equipment from the A. B. Dick firm. The data is supplied from the interface 85 to a printing system controller which forms print signals for the printer 56. The signals are binary in form in that they control the application of ink. In addition, the probe forms signals indicating its contact with the carton or crate 12. These signals, in conjunction with position sensors 92, indicate the whereabouts of the printer 56 with respect to the XYZ-axes.

The position sensors are mechanically connected to the apparatus shown in FIGS. 2 - 7 inclusive to indicate the whereabouts of the printer 56. These signals are provided to a printer mechanism interface 83. The digital control computer 81 provides signals to the printer mechanism interface 83 which then delivers driving signals to the XYZ-axis controllers 86, 87 and 88, inclusive. They form motor drive signals for the motors 23, 30, and 45. These signals are delivered to the print head assembly 15 previously described. Of course, a signal is provided for each motor. The print head assembly 15 includes limit switches. Limit switches are provided on the travelling assembly 19 which limit movement in the X-direction. These limit switches provide override signals to the X-axis control 86. Continued operation of the controls 86, 87 and 88 is indicated to the printer mechanism interface 83. This enables the printer mechanism interface to indicate to the computer 81 the whereabouts of the printer 56 and the possibility of encountering a limit. It will be understood that two types of limits can be encountered. One is a limit where the apparatus moves in the X, Y or Z-direction to the limit of its capabilities. That is to say, the motors 30, 23 or 45 have extended the equipment to the maximum. A second type of limit is that indicates by the position sensors 92. This is a limit which arises from the shape or construction of the package. This information is provided in the event of a defectively constructed crate or container, one which has ruptured or the like.

Attention is directed to FIG. 10 where a typical motor drive circuit is shown. The preferred motor is the

"slo-syn" previously mentioned. The motor 23 is driven by a translator circuit 97 which forms driving pulses applied on four wires to the motor which causes it to step incrementally through a step of 1.8°. The translator is controlled in operation by a signal conditioning circuit 98 which is supplied with the following inputs. One input is a direction signal which controls direction of rotation. Another input is the off-on input. A third input is an enable signal which enables an oscillator in the translator to run. Only one output is required and that is an end of step signal. Preferably, a pulse indicates completion of a step. The pulse is returned to the computer 81 (FIG. 9) to permit it to move on with the next step or operation. When the next step is finished, still another pulse indicates completion of the step and enables the next step.

The computer receives and scales the data to be formatted. The format must be converted to a scale which takes into account the gear ratio and actual physical measure of each step. The computer scans the data to be printed in its format and breaks it down into print signals for the printing means. Printing control is a binary function. As was discussed relative to FIG. 8, the formatted data is horizontally scanned and broken into a series of binary print signals.

Several factors relating to use of the present invention ought to be noted. The device is well able to print on curved surfaces. While the drawings and description connote a planar surface, many cardboard or wrapped cartons bulge and distort so that various portions of the surface on which the label is printed may be described as a curved surface. In like manner, the present invention can be used to print on drums and the like provided the included angle of the arc of the printed label is not so great that distortion occurs. For instance, it can print a label on a barrel or drum along the length of the drum if the label is only one or two lines tall. Printing around the diameter is limited by distortion at the extreme sides of the message where the included angle is great. The limits on angle may vary. For example, legibility is preserved where the included angle of the label is only 20° to 30°. When the angle is about 50° or so, the distortion becomes noticeable. When angles of this size are encountered, the label should be reformatted to decrease its total width, perhaps increasing label height, and thereby reducing the included angle.

Printing speed can be enhanced by using two or more print heads which print lines which are interlaced. The number can be increased subject to increased cost, and the speed of printing will be increased accordingly. When two or more print heads are used, they are offset from one another. This does not create any problem in operation inasmuch as the scanning of the formatted data interlaces the lines and the drying time of the ink is normally immaterial.

While the foregoing is directed to the preferred embodiment, the scope is determined by the claims appended hereto.

We claim:

1. A label printing apparatus for printing a label directly on a package, comprising:
 - probe means for finding the package on which a label is to be placed;
 - said probe means being movable relative to such a package to find a side thereof and including means forming a signal indicative of finding a side of the

package, and means contacting the package during printing;

print head means including means for applying ink for forming characters which comprise a portion of a label;

means for moving said print head means and said probe means in a specified pattern relative to the side of the package to enable said print head means to form the label on the package, said means for moving further including means responsive to said means contacting the package to control inward and outward movement of said print head means with respect to the package during printing; and control means for providing print signals to said print head means indicating the label to be printed and driving signals to said means for moving to control movement of said print head means with respect to the package.

2. The apparatus of claim 1 wherein said label printing apparatus is adapted to be placed adjacent to a path of movement of a succession of packages, and further including means for orienting the packages relative to said apparatus to enable a side to be presented to said apparatus whereupon said probe means is extended toward the side and moves into contact therewith.

3. The apparatus of claim 1 wherein said probe means and said print head means are moved by said motive means along the height and width of the side of a package.

4. The apparatus of claim 1 wherein said mean for moving includes:

- a pair of generally parallel and separated rotatable lead screws;

- a travelling nut on each of said lead screws;

- a supportive structure spanning between said travelling nuts and moved therewith;

- a lead screw incorporated in said supportive structure at right angles to said pair of lead screws;

- a travelling nut on said lead screw; and

- means connecting said travelling nut to said probe means to convey movement in two orthogonal directions to said probe means.

5. The apparatus of claim 4 wherein said means for moving includes means for moving said probe means bi-directionally along a third orthogonal direction.

6. The apparatus of claim 5 wherein said print head means includes means for positioning said print head means within a specified range of a package.

7. The apparatus of claim 1 wherein said moving means moves said probe means and said print head means as a unit along a path toward and away from the package, and further including a motor and connected motor control circuit means which drives said probe means and said print head means along the path.

8. The apparatus of claim 7 wherein said motor rotates a lead screw which engages a travelling nut which is secured relative to said probe means.

9. The apparatus of claim 7 including a pair of spaced guide means adjacent to said probe means for mounting said probe means for movement along the path.

10. The apparatus of claim 7 wherein said moving means includes a support mounting said print head means to the rear of said probe means.

11. The apparatus of claim 1 including
 - a generally upright support;
 - a carriage means movably mounted on said support;

11

12

second means for moving said carriage means vertically on said support;
 third means on said carriage movable to the right and left and perpendicular to said second moving means;
 said third means including a movable structure supporting said movable means and said probe means for movement perpendicular to the operation of said second means.
 12. The apparatus of claim 11 wherein said second and third moving means include stepping motors.
 13. The apparatus of claim 11 wherein said second moving means connects to a rotatable screw which advances said carriage means.
 14. The apparatus of claim 11 wherein said carriage means includes a pair of parallel guide members, one of which is rotatable in cooperation with said third moving means.
 15. The apparatus of claim 1 further including an ink applicator in said print head means which is supported above and to the rear of said probe means.
 16. A label printing apparatus for directly printing a label onto a container, comprising:
 a. printer means for forming the label by selectively applying ink directly to the container under control of a series of print signals;
 b. print head means for moving said printer means in a sequence of scanning movements with respect to the container so that the printer may selectively apply ink to form the label on a surface of the container; and
 c. probe means for contacting the surface of the container being printed and for sensing the position of

said printer means with respect to the container during printing;
 d. control computer means comprising:
 1. means for forming print signals, in accordance with the information content of the label to be printed, to control ink application by said printer means; and
 2. means for providing driving signals to control movement of said print head means in the sequence of scanning movements with respect to the container wherein the label is directly printed onto the container, and
 e. means for controlling inward and outward movement of said print head means with respect to the container in response to said probe means to accommodate for small variations in the container surface.
 17. The apparatus of claim 16, wherein a succession of containers are moved past said apparatus to receive labels with varying information, and wherein said control computer means comprises:
 means for forming print signals in accordance with the varying information content of the labels to be printed.
 18. The apparatus of claim 16, further including:
 motor means for driving said print head means to thereby move said printer means.
 19. The apparatus of claim 18, wherein said means for providing driving signals of said control means comprises:
 motor drive circuit means for providing driving signals to said motor means.

* * * * *

35
40
45
50
55
60
65