



US008650917B2

(12) **United States Patent**
McAllister et al.

(10) **Patent No.:** **US 8,650,917 B2**

(45) **Date of Patent:** **Feb. 18, 2014**

(54) **CLEANING APPARATUS INDICATING OPERATIONAL INFORMATION FOR A BULK DISPENSING SYSTEM**

(75) Inventors: **Karl D. McAllister**, Stevensville, MI (US); **Michael T. Dalton**, Saint Joseph, MI (US)

(73) Assignee: **Whirlpool Corporation**, Benton Harbor, MI (US)

(*) Notice: Subject to any disclaimer, the term of this patent is extended or adjusted under 35 U.S.C. 154(b) by 0 days.

(21) Appl. No.: **13/608,139**

(22) Filed: **Sep. 10, 2012**

(65) **Prior Publication Data**

US 2013/0000361 A1 Jan. 3, 2013

Related U.S. Application Data

(62) Division of application No. 12/165,873, filed on Jul. 1, 2008, now Pat. No. 8,286,288.

(51) **Int. Cl.**
D06F 39/02 (2006.01)

(52) **U.S. Cl.**
USPC **68/12.18**; 68/17 R

(58) **Field of Classification Search**
USPC 68/12.18, 12.23, 17 R
See application file for complete search history.

(56) **References Cited**

U.S. PATENT DOCUMENTS

5,390,385	A *	2/1995	Beldham	8/158
5,897,671	A *	4/1999	Newman et al.	8/158
6,918,398	B2 *	7/2005	Edelmann et al.	134/57 D
2003/0009428	A1 *	1/2003	Barbe	705/413
2004/0084065	A1 *	5/2004	Edelmann et al.	134/18
2004/0098811	A1 *	5/2004	Tuttle et al.	8/158
2004/0244819	A1 *	12/2004	Edelmann et al.	134/18
2006/0117811	A1 *	6/2006	Kinnetz	68/17 R
2009/0095028	A1 *	4/2009	Hoppe et al.	68/12.04
2009/0235962	A1 *	9/2009	Classen et al.	134/57 D

* cited by examiner

Primary Examiner — Joseph L Perrin

(57) **ABSTRACT**

An apparatus for determining the number of doses and the types of a treating chemistry available in a bulk dispensing system, and providing an indication of the determination on a user interface.

7 Claims, 3 Drawing Sheets

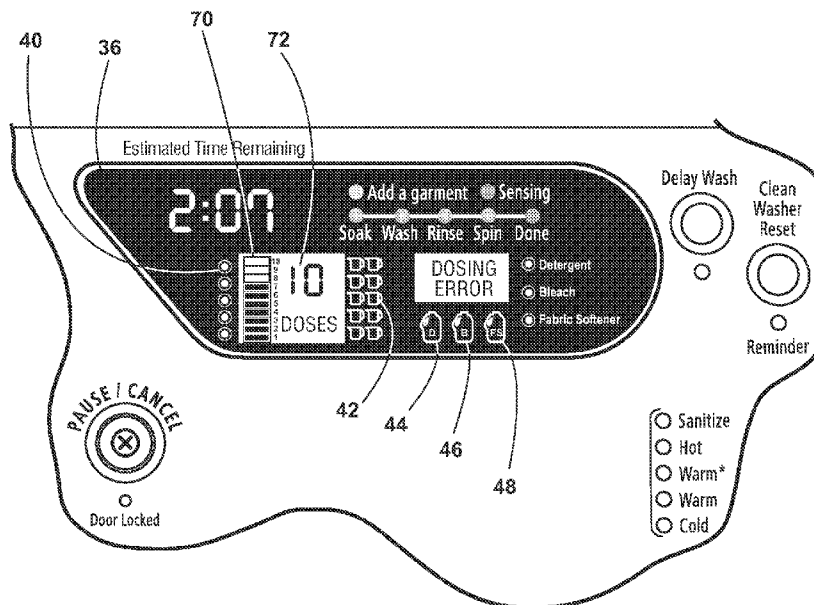

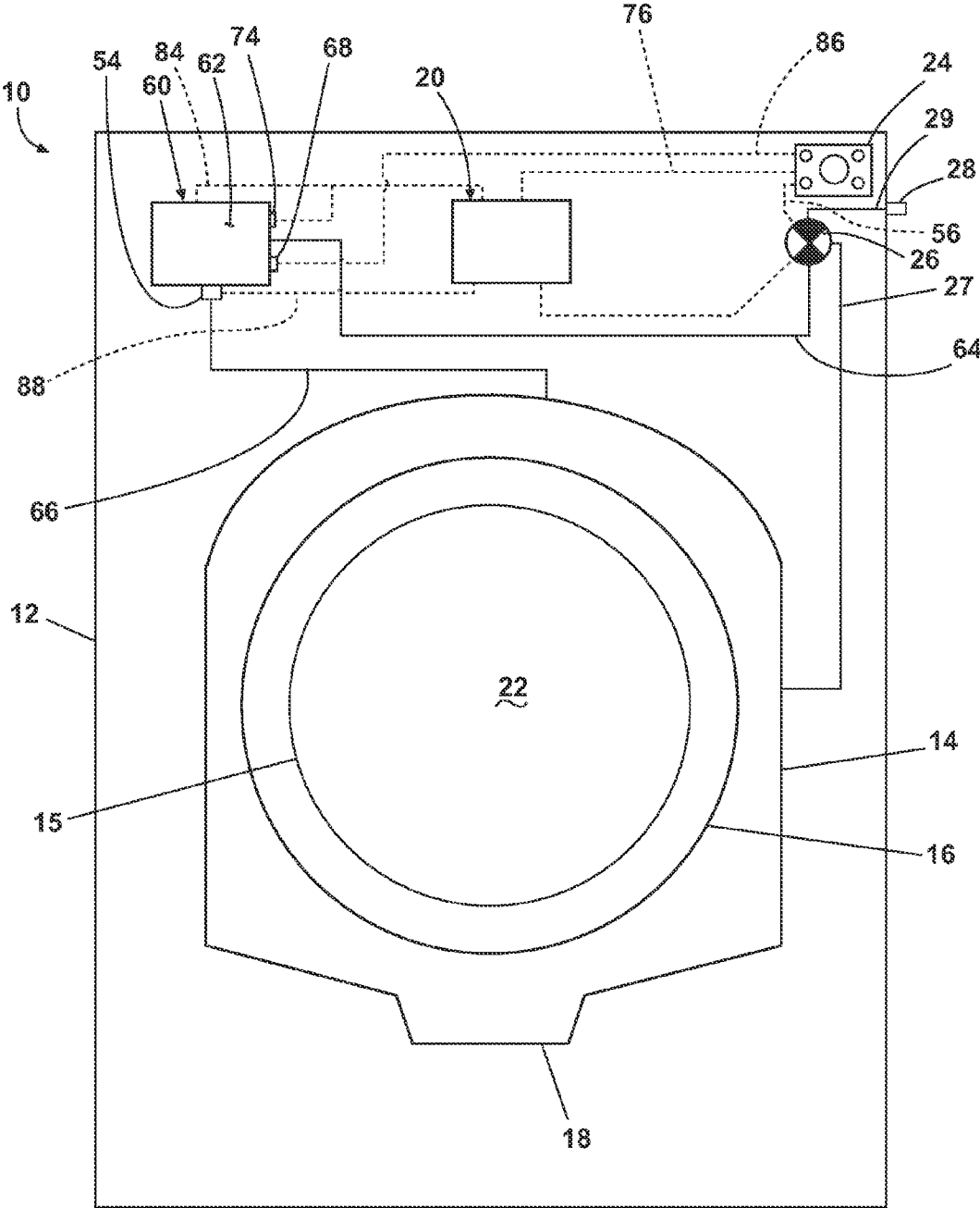

Fig. 1

CLEANING APPARATUS INDICATING OPERATIONAL INFORMATION FOR A BULK DISPENSING SYSTEM

CROSS-REFERENCE TO RELATED APPLICATIONS

The present application represents a divisional application of U.S. patent application Ser. No. 12/165,873 entitled "Method of Indicating Operational Information for a Bulk Dispensing System," filed Jul. 1, 2008, now U.S. Pat. No. 8,286,288, issued Oct. 16, 2012.

BACKGROUND OF THE INVENTION

Cleaning appliances, such as dishwashers or clothes washers, are often provided with a dispensing system for automatically dispensing one or more treating chemistries during a cleaning cycle. One common type of dispenser is the manual or single use dispenser, which may be filled with a dose of treating chemistry sufficient for a single cleaning cycle. Another type of dispenser is a bulk dispenser, which contains an amount of treating chemistry sufficient for multiple cleaning cycles. The bulk dispensing systems, while known, are not very common in household appliances. Some systems are capable of controlling and varying the amount of treating chemistry. These systems are more convenient to the user in the sense that the user only has to remember to fill them once every few cycles of operation.

SUMMARY OF THE INVENTION

A method of determining the number of doses and the types of a treating chemistry available in the bulk dispensing system, and providing an indication of the determination on a user interface.

BRIEF DESCRIPTION OF THE DRAWINGS

In the drawings:

FIG. 1 is a schematic view of an automatic clothes washing machine having a dispensing system and user interface according to an embodiment of the invention.

FIG. 2 is a detail view of the user interface of the cleaning appliance of FIG. 1 according to one embodiment of the invention.

FIG. 2A is a detail view of the user interface illustrated in FIG. 2 according to one embodiment of the invention.

DESCRIPTION OF THE EMBODIMENTS OF THE INVENTION

FIG. 1 illustrates a household cleaning appliance in which one method embodying the invention may be implemented. The cleaning appliance is shown in the environment of a horizontal axis automatic clothes washing machine 10. Although much of the remainder of this application will focus on the embodiment of an automatic clothes washing machine, the invention may have utility in other environments, including other cleaning appliances, such as dryers, combination washer-dryers, fabric fresheners, and dishwashers, or other non-cleaning appliances such as refrigerators. The automatic clothes washing machine 10 shares many features of a conventional automated clothes washer, which will not be described in detail herein except as necessary for a complete understanding of the invention.

Further, washing machines are typically categorized as either a vertical axis washing machine or a horizontal axis washing machine. As used herein, the "vertical axis" washing machine refers to a washing machine having a rotatable drum that rotates about a generally vertical axis relative to a surface that supports the washing machine. However, the rotational axis need not be vertical. The drum may rotate about an axis inclined relative to the vertical axis. As used herein, the "horizontal axis" washing machine refers to a washing machine having a rotatable drum that rotates about a generally horizontal axis relative to a surface that supports the washing machine. In some horizontal axis washing machines, the drum rotates about a horizontal axis generally parallel to a surface that supports the washing machine. However, the rotational axis need not be horizontal. The drum may rotate about an axis inclined relative to the horizontal axis, with fifteen degrees of inclination being one example of inclination.

Vertical axis and horizontal axis machines are best differentiated by the manner in which they impart mechanical energy to the fabric articles. In vertical axis machines, typically a fabric moving element moves within a drum to impart mechanical energy directly to the clothes or indirectly through wash liquid in the drum. In horizontal axis machines mechanical energy is typically imparted to the clothes by the tumbling action formed by the repeated lifting and dropping of the clothes, which is typically implemented by the rotating drum, although horizontal axis machines could also include fabric moving elements.

While technology and methods are not always interchangeable between vertical and horizontal axis machines, the invention disclosed herein may be suitable for use in both horizontal axis and vertical axis automatic clothes washing machines. The invention will be illustrated and described, however, in the context of a horizontal axis washing machine.

The automatic clothes washing machine 10 may include a cabinet 12 enclosing components typically found in a conventional washing machine, such as motors, pumps, fluid lines, controls, sensors, transducers, and the like. A door 15 may be mounted to the cabinet to selectively close an access opening to the interior of a tub 14 that defines a wash chamber 22 in which fabric articles, collectively forming a load of laundry, are treated. Both the tub 14 and a drum 16 are suspended in the interior of the cabinet 12. The tub 14 may be associated with a sump 18 for temporarily holding a liquid used during a cleaning cycle. The liquid may be only water or may be a mixture of water and a treating chemistry, such as a detergent. Other treating chemistries, such as bleach or softener, may also be in the mixture.

The cabinet 12 may include a user interface 20 that has operational controls such as dials, lights, switches, and displays enabling a user to input commands to a controller 24 and receive information about a specific cleaning cycle. The user interface 20 may be electrically coupled with the controller 24 through user interface leads 76. When the controller 24 is a microprocessor controller, the various cleaning cycles capable of being implemented by the controller 24 may be stored in internal memory of the controller 24 or memory associated with the controller 24. These cycles may be any desired cycle, including all currently known cycles.

With respect to a washing machine, the term cleaning cycle may be used to mean one operational cycle of the automatic clothes washing machine 10 that cleans a laundry load having one or more articles. The term cleaning cycle is not limited to a wash cycle in the traditional sense where laundry is washed in a water and detergent solution. The term cleaning cycle

may include applying a treating chemistry to the laundry, or to a treating cycle in combination with or part of a traditional cleaning cycle.

A multi-use or bulk dispensing system **60** may also be located in the cabinet **12** and may dispense treating chemistry during a cleaning cycle. The treating chemistry may be any type of aid for treating fabric, and examples may include, but are not limited to washing aids, such as detergents and oxidizers, including bleaches, and additives, such as fabric softeners, sanitizers, de-wrinklers, and chemicals for imparting desired properties to the fabric, including stain resistance, fragrance (e.g., perfumes), insect repellency, and UV protection.

As used herein, the term multiple doses of treating chemistry, and variations thereof, refers to an amount of treating chemistry sufficient for multiple cleaning cycles of the automatic clothes washing machine.

Looking at the components of the washing machine in greater detail, the controller **24** may be operably coupled to the bulk dispensing system **60**. In this way, the controller **24** may control the selective dispensing of treating chemistry to the wash chamber **22** during the cleaning cycle from the bulk dispensing system **60**.

The water control system may also include a conduit **29** fluidly coupling a control valve **26** to a household water supply **28**. The valve **26** is fluidly coupled to the tub **14** and bulk dispensing system **60** by dispensing lines **27** and **64**, respectively. In this way, the valve **26** may be used to control the selective distribution of the household water supply to the water-using components of the washing machine **10**.

A dispensing line **66** may fluidly couple the bulk dispensing system **60** with the tub **14**. Thus, fresh water may be delivered from the water supply **28** through the conduit **29**, valve **26** and to dispensing line **64** into the bulk dispensing system **60** for flushing treating chemistry there from and to the tub through the dispensing line **66**. The valve **26** may be electrically coupled with the controller **24** through a valve control lead **56**. The controller **24** may control the operation of the valve **26** in response to instructions received from the user interface **20** as a result of selections made by the user, such as cleaning cycle, water temperature, spin speed, extra rinse, and the like.

The bulk dispensing system **60** may include at least one bulk dispensing chamber **62** that is sized to store multiple doses of treating chemistry that may be selectively dispensed into the tub **14** or the wash chamber **22** as part of the execution of the cleaning cycle. The bulk dispensing chamber **62** may further be provided with one or more sensors **68** that may be used to provide information about the status of the bulk dispensing system, such as: type of treating chemistry, amount of treating chemistry, and amount dosed, for example. The sensor **68** may be in communication with the controller **24** via a lead **86**. The controller **24** may use the information to control a wash cycle or to display the information on the user interface **20**. For example, if the sensor **68** is a fill indicator used to determine the amount of treating chemistry in the chamber **62**, the controller may display this information on the user interface **20** for viewing by the consumer.

The fill indicator **68** may be any suitable type of sensor. It may be a direct sensor or an indirect sensor. A direct sensor will provide an output, such as a signal, that is indicative of the desired sensed condition. An indirect sensor will provide an output, such as a signal that is further processed, such as by the controller **24**, to make a final determination for the desired sensed condition. In the case of a fill indicator **68**, it may be an indirect sensor that provides a signal indicative of a volume level that the controller **24** uses to determine how full is the

treating chemistry chamber. The sensor may also be a float-type indicator, a light-type indicator, or an alarm-type indicator. The fill indicator **68** may be any combination of visible or audible indication. The manner in which the sensing is accomplished is not germane to the invention and may include such methods as resistive, inductance or capacitance sensing.

The bulk dispensing chamber **62** may also include a sensor **74** indicating the presence of treating chemistry in the bulk dispensing chamber **62**. The sensor **74** may be used to determine whether treating chemistry is or is not present in the bulk dispensing chamber **62**, while the fill indicator **68** may be used to determine the amount of treating chemistry in the chamber **62**. Multiple sensors **74** may indicate the presence of treating chemistry in multiple chambers within the dispensing chamber **62**. The sensor **74** may be any suitable type of sensor, such as a pressure sensor, level sensor, or proximity sensor, for sensing the presence of treating chemistry in the dispensing chamber **62**. Regardless of the type, the sensor **74** may send a signal to the controller **24**, via the user interface **20**, through lead **84** to indicate the presence of the treating chemistry in the dispensing chamber **62**. The foregoing description may be of an exemplary sensor location; other locations may be utilized for the sensor **74**.

The bulk dispensing system **60** may further include a treating chemistry meter **54** to dispense a predetermined amount of treating chemistry each cleaning cycle. The predetermined amount may vary from cycle-to-cycle, even for the same cycle, and will typically be set by the controller **24**. The treating chemistry meter **54** may be a mechanical flow meter, a magnetic flow meter, or any other meter suitable for measuring liquid flow, all well known in the cleaning appliance art. The treating chemistry meter **54** may send a signal to the user interface **20** through lead **88** that is indicative of or used to determine the amount of treating chemistry that has been dispensed to the wash chamber **22**.

While not illustrated, the bulk dispensing system **60** is capable of receiving and containing multiple types of treating chemistry in multiple chambers within the dispensing chamber **62**. Each chamber may hold the chemistry or a removable container, such as a cartridge, containing the treating chemistry. Although the bulk dispenser cartridge has been illustrated or described as a rectangular box-like container, the bulk dispensing cartridge may be any type of removable container configured to store multiple doses of a treating chemistry. The container may have any shape and size that is receivable within the dispenser. The removable container may be flexible, rigid, expandable, or collapsible. The container may be made of any type of material. Some examples of suitable cartridges are, without limitation, a plastic container, a cardboard container, a coated cardboard container, and a bladder, all of which are capable of being received within the dispenser.

Regardless of whether one or more treating chemistries are stored in the bulk dispensing system **60**, the controller **24** may recognize the type of treating chemistry present in the dispensing chamber **62** through several methods. Examples of these recognition methods include, but are not limited to, user input, utilizing a keyed treating chemistry cartridge or cartridge with a RFID (radio-frequency identification) tag or chip, or sensors **74**, such as refractive incidence sensors, to sense the type of chemistry. These methods may communicate to the controller **24** which of the various treating chemistries have been inserted into the dispensing chamber **62**. The determined types of treating chemistry may be communicated to the controller **24** via lead **84**, for display on the user interface **20**.

Referring to FIG. 2, a detail view of the user interface 20 according to one implementation of the invention is shown. The user interface 20 may have a combination of operational controls such as dials, lights, switches, buttons, and displays enabling a user to input commands to a controller 24 and to receive information about a specific cleaning cycle. The user interface, as described here, is not limited to a visual display, but also includes communication to and from the user such as an audible indicator, a microphone, or a camera for example. Also, the term display should not be limited to a visual indicator, but should be defined to also include an audible indicator.

The user interface 20 may include the user inputted selection of fabric type, water temperature, spin speed, and wash delay, soil level, and cycle signal. The user interface 20, according to one implementation of the invention, further includes an indication of the determination of the number of doses of treating chemistry available in the bulk dispensing system 60 for supplying the operation of the cleaning cycle. Given this determination, an indication is provided on the user interface 20. This indication may be displayed as a visual indicator, an audible indicator, or both.

In an exemplary implementation, a remaining number of doses of treating chemistry in the bulk dispenser 60 may be determined by the controller 24 based on a reference dose size and a determined amount of treating chemistry present in the dispensing chamber 62. The reference dose size may be a standard dose size as determined by the manufacturer and inputted into the controller 24, or may be based on historical usage data for the washing machine 10. As described above, the historical usage data may be provided to the controller 24 by the treating chemistry meter 54, which may determine the amount of treating chemistry that has been dispensed to the wash chamber 22. This historical usage data may be stored in internal memory of the controller 24 or memory associated with the controller 24. For example, the meter 54 may be a mechanical type flow meter that has a component that rotates within a chamber of known volume. For each rotation, an amount of water passes through the chamber. A gear or magnetic drive counts the number of turns and sends a signal to the controller 24, which keeps a running total of the volume that has been recorded to have passed through the meter 54. This volume relates to a dose size, which may be compared to the set dose size, and then stored in the controller's 24 memory as the historical usage data.

The historical usage data may be any usage data that is indicative of dose size, examples of which include executed cycles and/or actual dose size. For example, different cycles may have different dose sizes. That is, a cycle for a large load may have a different dose requirement than a dose for a cycle for a small load. The historical cycle data may be analyzed to track the most commonly executed cycle and use the corresponding dose size as the reference dose. Alternatively, the reference dose size may be a weighted average of the dose size for the executed cycles. Yet another alternative is to use the dose size for the last executed cycle as the reference dose size or to use the dose size for the currently selected cycle as the reference dose size.

In a similar way, the actual dose size may be analyzed over time to set the reference dose size. For example, the actual dose data may be analyzed for the most common dose size and select that as a reference dose size. An average dose size may be determined and used as the reference dose size. The dose size of the last cycle or the current cycle may also be used as the reference dose size.

When an average dose size is used, it may be determined in a number of different ways. For example, it may be deter-

mined as a running average over the entire length of the washing machine's 10 life cycle, or may be based on a predetermined number of recent cycles, for example a calculated average dosage size over the last ten cycles.

Regardless of how the reference dose size is determined, the number of doses remaining may be determined by dividing the remaining treating chemistry by the reference dose size. The amount of treating chemistry sensed to be present in the dispensing chamber 62 may be directly determined by the sensor 68, which may be a fill indicator. With the above information, the sensed amount of treating chemistry may be compared to the reference dose size to determine a remaining number of doses present in the dispensing chamber 62.

Other alternatives for determining the remaining doses are possible and the invention is not limited to the particular method in which the reference dose size is determined. For example, it is not necessary to use a reference dose size. One such method would include determining or assuming that a set number of doses for the bulk dispensing system and then decrementing the set number of doses for each executed cycle until the bulk dispensing system is refilled. The amount decremented may be assumed to be one per cycle or it may be determined in one of the ways previously described. Again, the manner in which the remaining doses are determined is not limiting to the invention.

As shown in FIG. 2A, the determination of the remaining number of doses may be displayed on the user interface 20 by means of a series of icons 42; an alpha-numeric 72 reading on an LCD screen 36, or similar; a bar 70 reading to be proportionally illuminated; or a stack of lights 40 to be proportionally illuminated. This information is provided to the user interface 20 for display via the lead 76, as determined by the controller 24.

Further, the determination of the remaining number of doses may be displayed on the user interface 20 when the appliance is powered on. The particular method, as described above, for determining the reference dose size will have been established within the controller 24 and the user interface 20 may display the according number of doses remaining at the time the appliance is powered on. If the chosen method for determining the reference dose size is based on the dose size of the current cycle, the determination of the remaining number of doses may be displayed on the user interface 20 at the time the user selects the dose size for the current cycle.

In addition to displaying the remaining doses, the types of treating chemistries may also be displayed. For example, an alpha-numeric 72 character of each wash type to be displayed on the LCD screen 36, or similar. Alternatively, an iconic representation 44, 46, 48 of each of the types of treating chemistry may be displayed. Exemplary icons are shown in FIG. 2A.

Further, the user interface 20 may also display the status of the dosing operation of the bulk dispensing system 60 by providing an indication if the treating chemistry was determined not to have dispensed. During operation, it may be that the treating chemistry may not be dispensed for several reasons; for example, an absence of treating chemistry in the dispensing chamber 62, or a determined insufficient amount of treating chemistry present in the dispensing chamber 62 for the selected cycle. The absence of treating chemistry, or the determination that there is an insufficient amount present in the dispensing chamber may be made by the sensor 68, as described above. In the case that an insufficient amount of a particular treating chemistry is determined to be present, the controller 24 will effect the dispensing of the entire content of that particular chemistry. The determination that the treating chemistry was not dispensed is provided to the user interface

20 for display via the lead 88, as monitored throughout the cycle of operation by the sensor 68 and the treating chemistry meter 54.

An indication that the treating chemistry was not dispensed may be displayed on the user interface 20 by means such as an alpha-numeric 72 character to be displayed on the LCD screen 36, or similar. An exemplary alpha-numeric 72 character is the phrase “dosing error”, which may be displayed in the dosing information area on the user interface 20. Alternatively, an iconic representation 44, 46, 48 of each of the types of treating chemistry may be displayed, and may flash or blink to indicate an error status, for example.

Dependent on the particular cycle that the user selects prior to operation of the washing machine 10, one or more treating chemistries or combinations thereof may be required. The bulk dispensing system 60 is capable of dispensing the type or types of treating chemistry required for the different cycles of operation as selected by the user. The user interface 20 may display the determination of which of the types of treating chemistry are required for the selected cycle of operation. This determination is provided by the controller 24 to the user interface 20 for display via the lead 76. The required treating chemistries may be displayed by means of an alpha-numeric 72 reading on an LCD screen 36, or similar; or a representative icon 44, 46, or 48. For example, an alpha-numeric 72 indication, such as the word “detergent”, “bleach” or “fabric softener” may be displayed in the dosage information area on the user interface 20. Alternatively, each treating chemistry icon 44, 46, 48 may be displayed in the dosage information area on the user interface 20. Further, the appropriate alpha-numeric 72 character or icon 44, 46, 48 may be displayed at the time in the cycle of operation at which that particular chemistry is being dosed. The dosing information may be monitored by the sensor 68 or the treating chemistry meter 54. Optionally, the alpha-numeric 72 character or icon 44, 46, 48 may remain illuminated throughout the entire dispensing operation for that particular treating chemistry.

The method of the present invention offers many benefits to consumers, including feedback regarding the operation of the unit. The bulk dispensing system 60 eliminates the need for the user to remove a supply of treating chemistry from a storage space, fill a dispenser, and replace the supply of treating chemistry each time the washing machine 10 is operated. However, there may be some ambiguity inherent to a dispensing system providing for multiple cycles of operation and multiple treating chemistries. The described method and user interface 20 may eliminate that ambiguity by providing clear communication to the user regarding aspects of operation, such as the number of doses of treating chemistry remaining in the bulk dispenser and information regarding the type of treating chemistry being dosed.

The method of the present invention has been described thus far as relating primarily to a dose size and a reference dose size. However, another contemplated methodology of the invention may be related instead to volume. Like the method of determining and displaying the remaining number of doses, the remaining volume may be determined and displayed. This may be accomplished in several different ways.

One way in which the method of the present invention may relate to a volume instead of a dose size is by utilizing the above described level sensor. Given a known volume of the dispensing chamber 62, the level sensor may sense the level at which the treating chemistry fills the dispensing chamber 62 and provide that information to the controller 24. The provided information from the level sensor may be an absolute value, a percentage of the total volume of the dispensing

chamber 62, or any other representative value. This provided information may be used by the controller 24 to determine the remaining volume of treating chemistry present in the bulk dispensing system 60.

Given this determination, an indication may be provided on the user interface 20. As described above with regard to doses remaining, this indication may be displayed as a visual indicator, an audible indicator, or both. The indication may be displayed as a volumetric value, such as cups, ounces, milliliters, or equivalent. Further, the determination of the remaining volume may be displayed on the user interface 20 by means of a series of icons 42; an alpha-numeric 72 reading on an LCD screen 36, or similar; a bar 70 reading to be proportionally illuminated; or a stack of lights 40 to be proportionally illuminated.

While the invention has been specifically described in connection with certain specific embodiments thereof, it is to be understood that this is by way of illustration and not of limitation. Reasonable variation and modification are possible within the scope of the forgoing disclosure and drawings without departing from the spirit of the invention which is defined in the appended claims.

What is claimed is:

1. A cleaning apparatus having a laundry treating chamber, comprising:
 - a bulk treating chemistry dispenser configured to hold multiple doses of treating chemistry for dispensing into the laundry treating chamber;
 - a user interface configured to provide an indication to the user; and
 - a controller coupled with the user interface and the bulk treating chemistry dispenser and configured to execute an operating cycle and to control the user interface such that the user interface provides an indication of a number of doses of treating chemistry remaining in the bulk treating chemistry dispenser as the amount of treating chemistry is reduced from that of a filled dispenser to that of an emptied dispenser.
2. The cleaning apparatus of claim 1 further comprising a sensor operably coupled to the controller and configured to sense a condition of the treating chemistry in the bulk treating chemistry dispenser and provide a signal to the controller indicative of the number of doses of treating chemistry remaining in the bulk treating chemistry dispenser.
3. The cleaning apparatus of claim 2 wherein the controller controls the execution of the operating cycle based on the signal.
4. The cleaning apparatus of claim 2 wherein the controller controls the user interface to provide the indication of the number of doses remaining in the bulk treating chemistry dispenser on the user interface.
5. The cleaning apparatus of claim 4 wherein the user interface provides an iconic representation of the number of doses remaining in the bulk treating chemistry dispenser.
6. The cleaning apparatus of claim 5 wherein the iconic representation of the number of doses remaining in the bulk treating chemistry dispenser is an icon, an alpha-numeric reading, a bar reading to be proportionally illuminated, and/or a stack of lights to be proportionally illuminated.
7. The cleaning apparatus of claim 1 wherein the indication of a number of doses of treating chemistry remaining in the bulk treating chemistry dispenser is an indication of a number of doses of treating chemistry, each dose having a pre-selected volume.