

**(12) STANDARD PATENT**  
**(19) AUSTRALIAN PATENT OFFICE**

(11) Application No. **AU 2008286781 B2**

(54) Title  
**Platform for providing a social context to software applications**

(51) International Patent Classification(s)  
**G06Q 10/00 (2006.01)**

(21) Application No: **2008286781** (22) Date of Filing: **2008.08.14**

(87) WIPO No: **WO09/023790**

(30) Priority Data

(31) Number	(32) Date	(33) Country
<b>11/893,559</b>	<b>2007.08.15</b>	<b>US</b>

(43) Publication Date: **2009.02.19**

(44) Accepted Journal Date: **2012.11.08**

(71) Applicant(s)  
**Facebook, Inc.**

(72) Inventor(s)  
**Fetterman, Dave;Zhuo, Julie;Cheever, Charlie;Slee, Mark;Zamore, Eric;Morin, Dave;D'Angelo, Adam;Steinberg, Ari;Wang, James;Sanghvi, Ruchi**

(74) Agent / Attorney  
**Spruson & Ferguson, Level 35 St Martins Tower 31 Market Street, Sydney, NSW, 2000**

(56) Related Art  
**US 2005/0216300 A1**

(19) World Intellectual Property Organization  
International Bureau



(43) International Publication Date  
19 February 2009 (19.02.2009)

PCT

(10) International Publication Number  
WO 2009/023790 A1

- (51) International Patent Classification:  
G06Q 10/00 (2006.01)
- (21) International Application Number:  
PCT/US2008/073202
- (22) International Filing Date: 14 August 2008 (14.08.2008)
- (25) Filing Language: English
- (26) Publication Language: English
- (30) Priority Data:  
11/893,559 15 August 2007 (15.08.2007) US
- (71) Applicant (for all designated States except US): FACEBOOK, INC. [US/US]; 156 University Avenue, Palo Alto, CA 94301 (US).
- (72) Inventors; and
- (75) Inventors/Applicants (for US only): D'ANGELO, Adam [US/US]; C/o Facebook, Inc., 156 University Avenue, Palo Alto, CA 94301 (US). FETTERMAN, Dave [US/US]; C/o Facebook, Inc., 156 University Avenue, Palo Alto, CA 94301 (US). CHEEVER, Charlie [US/US]; C/o Facebook, Inc., 156 University Avenue, Palo Alto, CA 94301 (US). STEINBERG, Ari [US/US]; C/o Facebook, Inc., 156 University Avenue, Palo Alto, CA 94301 (US). ZAMORE, Eric [US/US]; Facebook, Inc., 156 University Avenue, Palo Alto, CA 94301 (US). WANG, James [UY/GB]; Facebook, Inc., 156 University Avenue, Palo Alto, CA 94301 (US). ZHUO, Julie [US/US]; Facebook,

Inc., 156 University Avenue, Palo Alto, CA 94301 (US). MORIN, Dave [US/US]; Facebook, Inc., 156 University Avenue, Palo Alto, CA 97301 (US). SLEE, Mark [US/US]; Facebook, Inc., 156 University Avenue, Palo Alto, CA 94301 (US). SANGHVI, Ruchi [GB/US]; Facebook, Inc., 156 University Avenue, Palo Alto, CA 94301 (US).

(74) Agents: HULSE, Robert, A. et al.; Fenwick & West LLP, Silicon Valley Center, 801 California Street, Mountain View, CA 94041 (US).

(81) Designated States (unless otherwise indicated, for every kind of national protection available): AE, AG, AL, AM, AO, AT, AU, AZ, BA, BB, BG, BH, BR, BW, BY, BZ, CA, CH, CN, CO, CR, CU, CZ, DE, DK, DM, DO, DZ, EC, EE, EG, ES, FI, GB, GD, GE, GH, GM, GT, HN, HR, HU, ID, IL, IN, IS, JP, KE, KG, KM, KN, KP, KR, KZ, LA, LC, LK, LR, LS, LT, LU, LY, MA, MD, ME, MG, MK, MN, MW, MX, MY, MZ, NA, NG, NI, NO, NZ, OM, PG, PH, PL, PT, RO, RS, RU, SC, SD, SE, SG, SK, SL, SM, ST, SV, SY, TJ, TM, TN, TR, TT, TZ, UA, UG, US, UZ, VC, VN, ZA, ZM, ZW.

(84) Designated States (unless otherwise indicated, for every kind of regional protection available): ARIPO (BW, GH, GM, KE, LS, MW, MZ, NA, SD, SL, SZ, TZ, UG, ZM, ZW), Eurasian (AM, AZ, BY, KG, KZ, MD, RU, TJ, TM), European (AT, BE, BG, CH, CY, CZ, DE, DK, EE, ES, FI, FR, GB, GR, HR, HU, IE, IS, IT, LT, LU, LV, MC, MT, NL,

[Continued on next page]

(54) Title: PLATFORM FOR PROVIDING A SOCIAL CONTEXT TO SOFTWARE APPLICATIONS

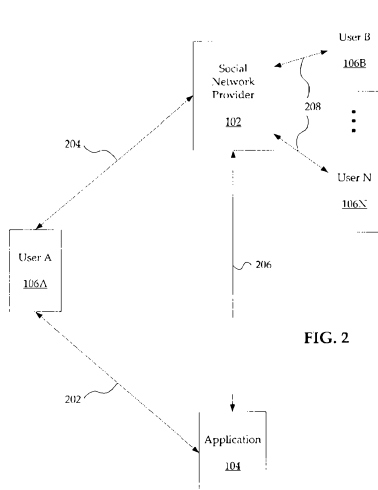

FIG. 2

(57) Abstract: The present invention provides a system and method for providing a social context to software applications. According to one embodiment of the invention, a user of a social network authorizes access by an external software application to information available in the social network. At some time later, the user of the social network uses an application designed by a third-party software developer. The application contacts the social network provider for permission to access the information available in the social network. If access has been authorized, the application incorporates the information from the social network into its interaction with the user, providing a social context to the user's interaction with the application.

WO 2009/023790 A1

WO 2009/023790 A1



---

NO, PL, PT, RO, SE, SI, SK, TR), OAPI (BF, BJ, CF, CG,  
CI, CM, GA, GN, GQ, GW, ML, MR, NE, SN, TD, TG).

**Published:**  
— *with international search report*

# PLATFORM FOR PROVIDING A SOCIAL CONTEXT TO SOFTWARE APPLICATIONS

By Adam D'Angelo, Dave Fetterman, Charlie Cheever, Ari Steinberg, Eric Zamore, James Wang, Julie Zhuo, Dave Morin, Mark Slee, and Ruchi Sanghvi

## BACKGROUND OF THE INVENTION

### Field of the Invention

[0001] This invention relates to internet application, and particularly to using an internet-based social network to provide a social context to a user's interaction with a third-party software application.

### Description of Related Art

[0002] Providers of internet-based social networks currently allow third-party software developers to develop applications that can interact with the social network. However, the social networks provide only limited information, and do not offer a social context to the application. That is, a user of the third-party application does not see what other users of the social network are doing, or access information about other users of the social network that is not publicly available information.

[0003] There is no currently available platform that a third-party developer of a software application may use to develop an application that draws a social context from information available in the social network.

## SUMMARY OF THE INVENTION

[0003A] In an aspect of the present disclosure, there is provided a method for providing a social networking system for an application, the method comprising:  
receiving, at the social networking system, an authorization from a user of the social networking system via a user device, the authorization permitting the application provided by a party other than a provider of the social networking system to access information about the user, the

information including information about one or more other users with whom the user has established a connection in the social networking system, and wherein the application provides content from a server on which the application is executed to the user device based on the accessed information about the one or more other users with whom the user has established a connection in the social networking system; receiving, at the social networking system, a request from the application for information about the user of the social networking system, the requested information comprising information about one or more other users with whom the user has a connection in the social networking system; verifying receipt of authorization from the user to provide the requested information to the requesting application; and subject to the verifying, providing the requested information from the social networking system to the requesting application.

[0003B] In a further aspect of the present disclosure, there is provided a system comprising: a processor; a non-transitory computer readable storage medium for storing software modules; a user information database configured to store and update information associated with users of a social network and authorization for the use of the information; an application programming interface configured to: receive an authorization from a user of the social networking system via a user device, the authorization permitting an application provided by a party other than a provider of the social networking system to access information about the user, the information including information about one or more other users with whom the user has established a connection in the social networking system, and wherein the application provides content from a server on which the application is executed to the user device based on the accessed information about the one or more other users with whom the user has established a connection in the social networking system; receive a request for information about the user stored in the user information database, the requested information comprising information about one or more other users with whom the user has a connection in the social networking system, and provide the requested information to the requesting application subject to an authorization by the user; and a verification module configured to: verify receipt of authorization from the user to provide the requested information to the requesting application, and to provide the authorization to the application programming interface if authorized.

[0003C] In a further aspect of the present disclosure, there is provided a computer program product for providing information about users of a social network for use in a software application, the computer program product comprising a non-transitory computer-readable storage medium containing computer program product code for performing the steps: receiving at the social networking system an authorization from a user of the social networking system via

a user device, the authorization permitting an application provided by a party other than a provider of the social networking system to access information about the user, including information about one or more other users with whom the user has established a connection in the social networking system, and wherein the application provides content from a server on which the application is executed to the user device based on the accessed information about the one or more other users with whom the user has established a connection in the social networking system; receiving at the social networking system a request from the application for information about the user of the social networking system, the requested information comprising information about one or more other users with whom the user has a connection in the social networking system; verifying receipt of authorization from the user to provide the requested information to the requesting application; and subject to the verifying, providing the requested information from the social networking system to the requesting application.

[0004] The present invention provides a system and method for providing a social context to software applications. According to one aspect of the present disclosure a user of a social network may authorize access by an external software application to information available in the social network. When the user of the social network uses the external application, the application contacts the social network provider for permission to access the information available in the social network. If access has been authorized, the application incorporates the information

from the social network into its interaction with the user, providing a social context to the user's interaction with the application.

#### BRIEF DESCRIPTION OF THE DRAWINGS

[005] FIG. 1 is a block diagram of an architecture connecting a social network provider, a software application, and users of computing devices over a network that may be used with the present invention.

[006] FIG. 2 is a block diagram showing exemplary interactions of a user with a social network provider and with a third-party software application according to the present invention.

[007] FIG. 3 is a block diagram of an exemplary social network provider offering a platform for providing a social context to a software application.

[008] FIG. 4 shows a screenshot of an exemplary external software application having a social context provided by a social network provider according to the present invention.

[009] FIG. 5 shows another screenshot of an exemplary external software application having a social context provided by a social network provider according to the present invention.

#### DETAILED DESCRIPTION OF THE INVENTION

[0010] The present invention provides a platform for using a social network to provide a social context to a software application that is external to the social network, such as an application developed by a third-party developer rather than the social network provider and/or which does not reside within the social network or social network provider. A social context comprises information that personalizes the interaction of a user with the software application.

[0011] A social network provider may offer access to a platform according to the present invention to a third-party developer of a software application, so that the developer may design an application that draws a social context from the social network. Such an application may then incorporate privacy-controlled information

about users of the social network, allowing the user of the application to experience the social context provided by the social network provider.

**[0012]** For example, a user of a social network may also wish to use a third-party software application that displays book reviews. If the user has authorized the social network provider to provide information associated with the user in the social network to an external application, then the user may access that information through the book review application. For example, the user may use the application to find book reviews on that application created by people with whom he has established connections in the social network. If the social network normally collects its own data on books, location, or any other set of its own data accessible through the provided application programming interface, the user may incorporate that data into his use of the third party application as well.

**[0013]** FIG. 1 is a block diagram of an architecture connecting a social network provider 102, a software application 104, and users 106 via computing devices over a network 108 that may be used with the present invention. Users 106, such as a user 106A, a user 106B, and a user 106N, communicate over a network 108 with a social network provider 102. The users 106A-106N may use any type of communication device compatible with the social network provider 102, such as a cellular telephone, a personal digital assistant, and/or a desktop or a laptop computer. Any type of communication device falls within the scope of various embodiments.

**[0014]** The social network provider 102 may comprise any user or entity that provides social networking services, for example, communication services, dating services, or other services for social interaction. For example, the social network provider 102 may host a website that allows one or more users 106 to communicate with one another via the website. In one instance, the user 106A may communicate with the user 106B via a social networking website associated with the social network provider 102 that offers the user an opportunity to connect or



reconnect with one or more other users 106B-106N who attended, for example, the same university as the user 106A.

**[0015]** According to some embodiments, a developer of an application 104 may contact the social network provider 102 and request an application key from the developer. The social network provider 102 may review the developer's proposed application 104 and approve interaction between the application 104 and the social network. Review and approval may take any desired form; for example, they may require review by a person or they may be automatic.

**[0016]** The application 104 may be any type of application, so that, for example, those that display still or moving images, those that play sounds such as music or speech, those for financial management, for calendaring, or for any purpose are within the scope of the invention. The application 104 may be written in any natural and/or computer language or languages.

**[0017]** When a user 106A encounters the application 104 and uses it in a way that requests access to information from the social network provider 102, the social network provider 102 checks to see whether the user of the application has provided authorization for access to the information by the application 104.

**[0018]** In some embodiments, a user of a social network may authorize external use of information available in the social network over which he has control. For example, the information may be associated with his user profile, account, userid (a piece of unique user identification), or any other data or data structure representing the user. Exemplary authorization methods include, but are not limited to, those in which: (1) the user opens an infinite session with the social network (as described in U.S. Provisional Patent Application Serial No. 60/906,961, titled "Systems and Methods for Network Authentication," filed on March 13, 2007); and (2) the user logs into the social network and through a checkbox menu or other display selects authorization settings for some or all of his information in the social network. Authorization may occur before or during the user's access to application 104, and may persist indefinitely until altered by the user or by the social network

provider 102. Alternatively, for example, the login process of the social network may start a clock that results in the expiration of the authorization after some time period; after expiration, a new authorization would be required. Thus, the user of the application 104 may be, but need not be, actively using the social network (for instance, through a window open on his computer's desktop) while accessing information available in the social network through the application 104.

**[0019]** Information available in the social network for use with the application 104 may be subject to privacy settings selected by the users 106 of the social network (as described in U.S. Patent Application Serial No. 11/493,291, titled "Systems and Methods for Dynamically Generating a Privacy Summary," filed on July 25, 2006). The privacy settings selections may be set either as a part of the authorization process described above, or independently. In such a case, the application 104 should be designed to incorporate privacy-controlled information about users 106 of the social network into the interaction of user 106A with the application 104, so that the privacy settings set by the user 106A in the social network are incorporated into the interactions of user 106A or other users with the application 104.

**[0020]** FIG. 2 is a block diagram showing exemplary interactions of a user 106A with a social network provider 102 and with a third-party software application 104. The user 106A is having an interaction 202 with the application 104 at the moment depicted. For the social network provider 102 to provide a social context for the application 104 that is personalized to user 106A, interactions 204 and 206 must be occurring and/or must have already occurred at the time of interaction 202.

**[0021]** In an exemplary embodiment, interaction 204 between a user 106A and a social network provider 102 comprises the authorization process described above, in which user 106A authorizes the access of information about user 106A by the application 104. Interaction 204 may optionally also comprise the selection of privacy settings by user 106A. Interaction 206 comprises one or more instances of access of data in the social network by the application 104. For example, an

application 104 that dynamically updates information from the social network will have frequent, multiple interactions 206 with the social network provider 102; such interactions 206 may be mediated or otherwise processed by one or more application processing interfaces as shown in FIG. 3. Interactions 208 comprise authorizations, privacy settings selections, and/or other information provided to the social network provider 102 by one or more users 106B – 106N, which similarly control access to their information by the application 104.

**[0022]** FIG. 3 is a block diagram of an exemplary social network provider 102 offering a platform for providing a social context to one or more software applications 104. The social network provider 102 may comprise a server, a client device, or any other device.

**[0023]** The social network provider 102 includes a user information database 302, a verification module 304, and an application programming interface 306, and may optionally also include a privacy settings selections component 308. The user information database 302 stores data associated with each user 106A – 106N of the social network, which may be accessible by a third-party application under appropriate conditions. When a user 106A authorizes access to one or more external applications, and/or selects or updates privacy settings associated with his information, the user information database 302 updates the data associated with user 106A. Accordingly, authorizations and privacy settings selections are stored in association with each user 106. Authorizations, privacy settings selections and other user 106 information may be stored, modified, added, or otherwise embodied or captured in any storage medium.

**[0024]** The verification module 304 verifies that the user 106A of an application 104 attempting to access information from the social network has authorized use of that information, as discussed herein.

**[0025]** The application programming interface 306 communicates with the application 104 over the network 108. The application 104 communicates various types of information, such as requests for information about user 106A, requests for

information about one or more users 106B – 106N, and optionally updates of information about user 106A, to the social network provider 102 through the application programming interface 306. Any type of application programming interface 306 is within the scope of various embodiments.

**[0026]** Optionally, a privacy settings selections component 308 receives privacy settings selections from a user 106, such as user 106A. The privacy settings selections component 308 updates the user information database 302 with the privacy settings selected by the user 106A.

**[0027]** Although the social network provider 102 is described as being comprised of various components (such as the user information database 302, the verification module 304, the application programming interface 306 and the privacy settings selections component 308), fewer or more components may comprise the social network provider 102 and still fall within the scope of various embodiments.

**[0028]** The social network provider 102 may provide any type of social network. That is, a social network may comprise users grouped according to any type of category, such as friends, users living near each other, and fellow alumni. The user may specify the networks and groupings, and/or the networks and groupings may be predetermined by the social network provider 102. Thus, a user 106A may be related to a user 106N in various ways through the social network, for example, by being included with user 106N in a group of users living in the Boston area.

**[0029]** FIG. 4 shows a screenshot 400 of an exemplary external software application 104 having a social context provided by a social network provider 102 according to the present invention. The application “MoochSpot” allows the user 106A to keep track of loans and debts to users 106B – 106N to whom user 106A is related through the group “friends” in the social network. While as illustrated, there is a link 402 that asks the user to log into the social network, in other embodiments the user need not be simultaneously logged into the social network.

**[0030]** FIG. 5 shows another screenshot 500 of an exemplary external software application 104 having a social context provided by a social network provider 102 according to the present invention. A portion 502 of the screen allows user 106A to create a “piggy bank” and invite his “friends” from among users 106B – 106N to join it. For example, a link 504 invites the user 106A to click and thereby be directed to another display of additional information (not shown); the social context provided to the application 104 for user 106A by the social network provider 102 is updated through the display of additional information about, and the creation of new relationships with, users 106B – 106N. A portion 506 of the screen also allows user 106A to view any financial transactions with users 106B – 106N through application 104. As these transactions occur, the social context provided to the application 104 will be updated accordingly.

**[0031]** While various embodiments have been described above, it should be understood that they have been presented by way of example only, and not limitation. Thus, the breadth and scope of a preferred embodiment should not be limited by any of the above-described exemplary embodiments.

CLAIMS:

1. A method for providing a social platform for software applications external to a social networking system, the method comprising:

receiving, at the social networking system, an authorization from a user of the social networking system via a user device, the authorization permitting a said software application provided by a party other than a provider of the social networking system to access information about the user, including information about one or more other users with whom the user has established a connection in the social networking system, and wherein the application provides content from a server on which the application is executed to the user device based on the accessed information about the one or more other users with whom the user has established a connection in the social networking system;

receiving, at the social networking system, a request from the application for information about the user of the social networking system, the requested information comprising information about one or more other users with whom the user has a connection in the social networking system;

verifying receipt of authorization from the user to provide the requested information to the requesting application; and

subject to the verifying, providing the requested information from the social networking system to the requesting application.

2. The method of claim 1, wherein the requested information comprises information about the user of the application.

3. The method of claim 1, wherein the requested information comprises information about one or more other users of the social networking system.
4. The method of claim 3, wherein the user has established a connection in the social networking system with the other users.
5. The method of claim 1, further comprising:  
receiving privacy settings from one or more of the other users of the social networking system with whom the user has established a connection, the privacy settings at least in part defining whether the application can make a particular user's information obtained from the social networking system available through the application to other users of the application.
6. The method of claim 5, further comprising:  
providing the privacy settings to the requesting application with the requested information.
7. The method of claim 1, further comprising:  
receiving privacy settings from the user of the social networking system, the privacy settings at least in part defining whether the application can make the user's information obtained from the social networking system available through the application to other users of the application with whom the user has established a connection in the social networking system.
8. A system comprising:  
a processor;  
a non-transitory computer readable storage medium for storing software modules;  
a user information database configured to store and update information associated with users of a social network and authorization for the use of the information;

an application programming interface configured to:

receive an authorization from a user of the social networking system via a user device, the authorization permitting a software application provided by a party other than a provider of the social networking system to access information about the user, including information about one or more other users with whom the user has established a connection in the social networking system, and wherein the application provides content from a server on which the application is executed to the user device based on the accessed information about the one or more other users with whom the user has established a connection in the social networking system;

receive a request for information about the user stored in the user information database, the requested information comprising information about one or more other users with whom the user has a connection in the social networking system, and

provide the requested information to the requesting application subject to an authorization by the user; and

a verification module configured to:

verify receipt of authorization from the user to provide the requested information to the requesting application, and  
to provide the authorization to the application programming interface if authorized.

9. The system of claim 8, further comprising a privacy settings selections component configured to:



receive privacy settings from one or more of the other users of the social networking system with whom the user has established a connection, the privacy settings at least in part defining whether the application can make a particular user's information obtained from the social networking system available through the application to other users of the application; and

providing the privacy settings to the requesting application with the requested information.

10. The system of claim 8, wherein the application programming interface is further configured to:

receive privacy settings from the user of the social networking system, the privacy settings at least in part defining whether the application can make the user's information obtained from the social networking system available through the application to other users of the application with whom the user has established a connection in the social networking system.

11. A computer program product for providing information about users of a social network for use in a software application, the computer program product comprising a non-transitory computer-readable storage medium containing computer program product code for performing the steps:

receiving, at the social networking system, an authorization from a user of the social networking system via a user device, the authorization permitting an application provided by a party other than a provider of the social networking system to access information about the user, including information about one or more other users with whom the user has established a connection in the social networking system, and wherein the application provides content from a

server on which the application is executed to the user device based on the accessed information about the one or more other users with whom the user has established a connection in the social networking system;  
receiving, at the social networking system, a request from the application for information about the user of the social networking system, the requested information comprising information about one or more other users with whom the user has a connection in the social networking system;  
verifying receipt of authorization from the user to provide the requested information to the requesting application; and  
subject to the verifying, providing the requested information from the social networking system to the requesting application.

12. The computer program product of claim 11, the computer-readable storage medium further containing computer program code for:

receiving privacy settings from the user of the social networking system, the privacy settings at least in part defining whether the application can make the user's information obtained from the social networking system available through the application to other users of the application with whom the user has established a connection in the social networking system.

13. The computer program product of claim 11, wherein the requested information comprises information about the user of the application.

14. The computer program product of claim 11, wherein the requested information comprises information about one or more other users of the social networking system.

15. The computer program product of claim 14, wherein the user has established a connection in the social networking system with the other users.

16. The computer program product of claim 13, the storage medium further containing computer program code for performing the steps:

receiving privacy settings from one or more of the other users of the social networking system with whom the user has established a connection, the privacy settings at least in part defining whether the application can make a particular user's information obtained from the social networking system [[is]] available through the application to other users of the application.

17. The computer program product of claim 14, the storage medium further containing computer program code for performing the steps:

providing the privacy settings to the requesting application with the requested information.

DATED this ninth Day of October, 2012

**Facebook, Inc.**

Patent Attorneys for the Applicant

SPRUSON & FERGUSON

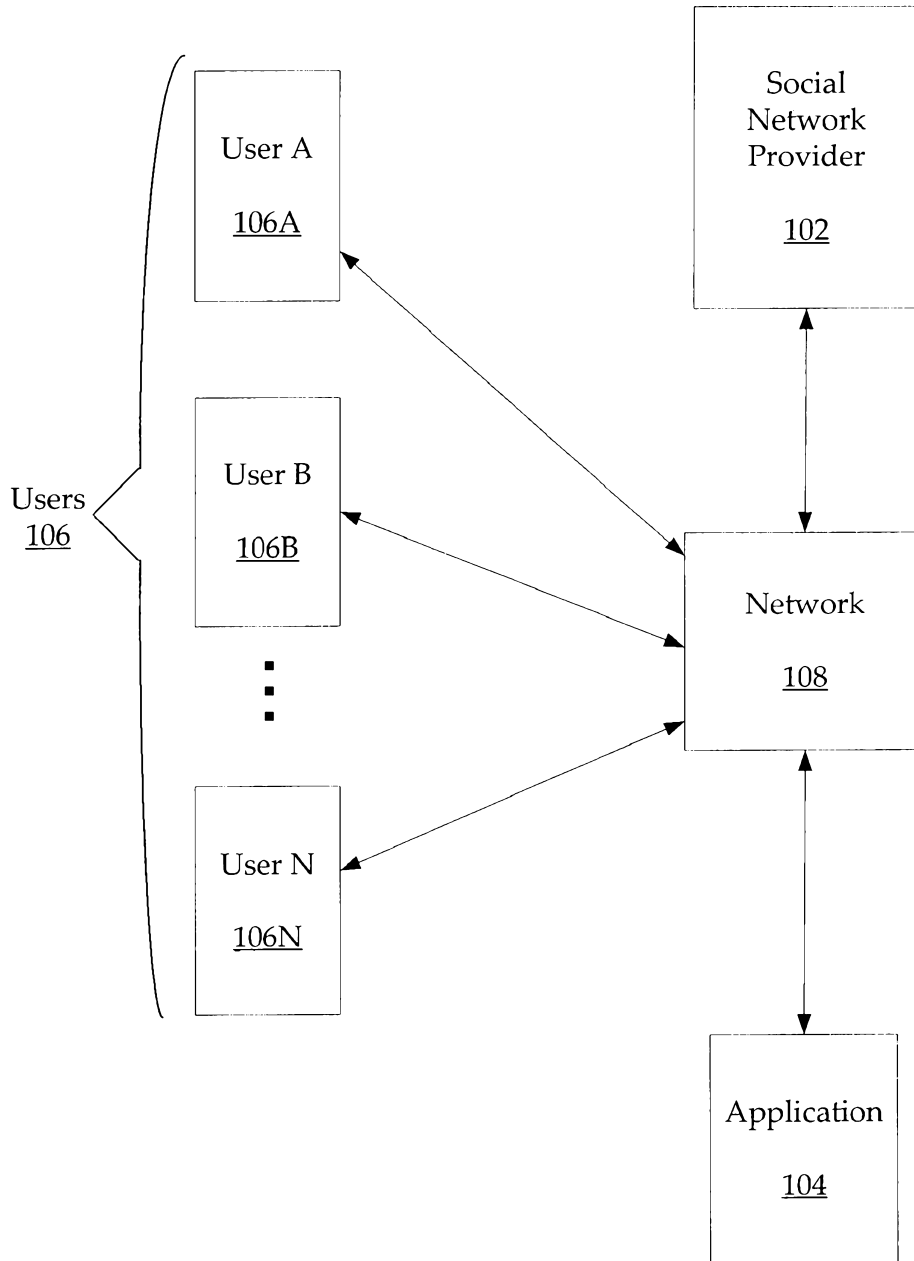

FIG. 1

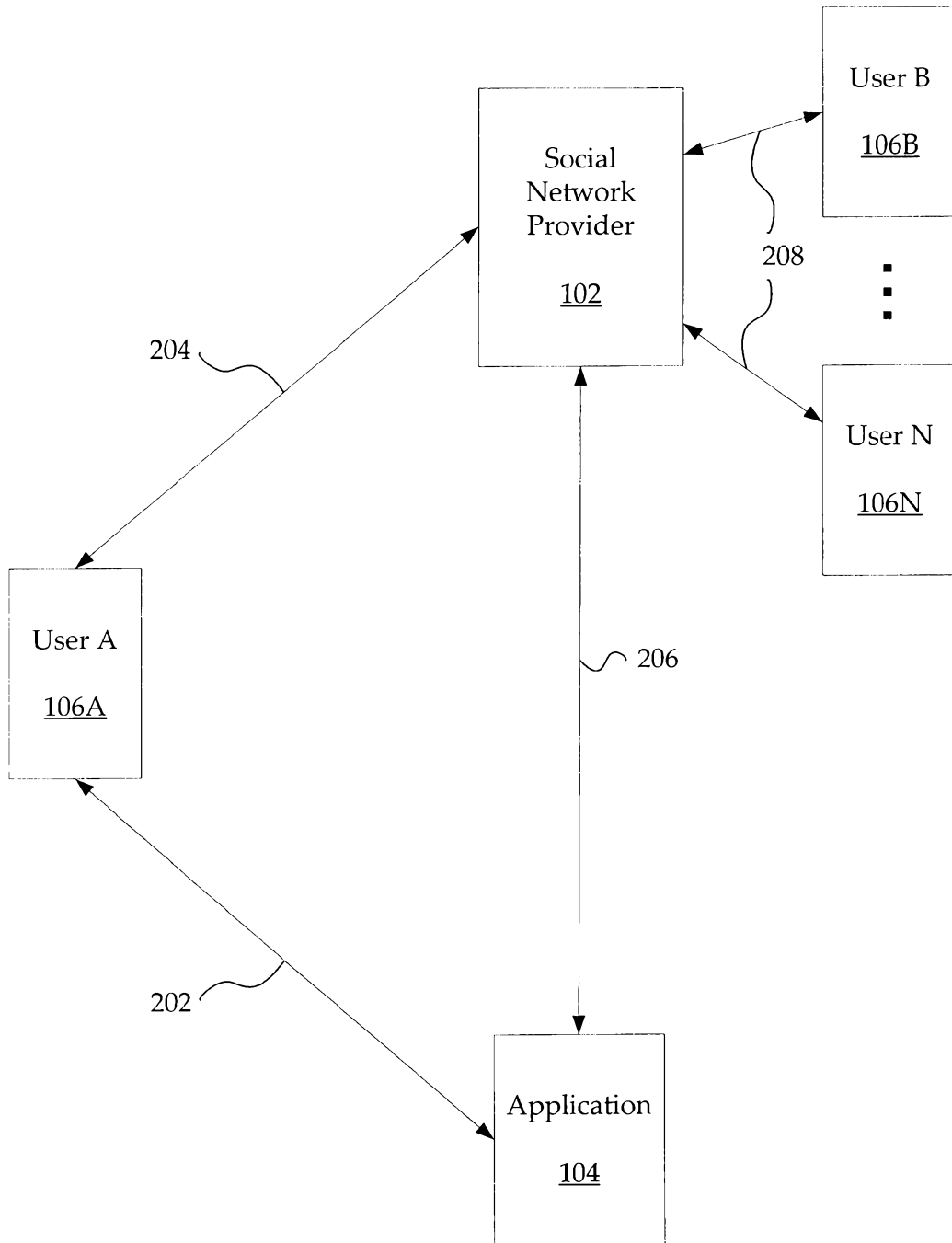

FIG. 2

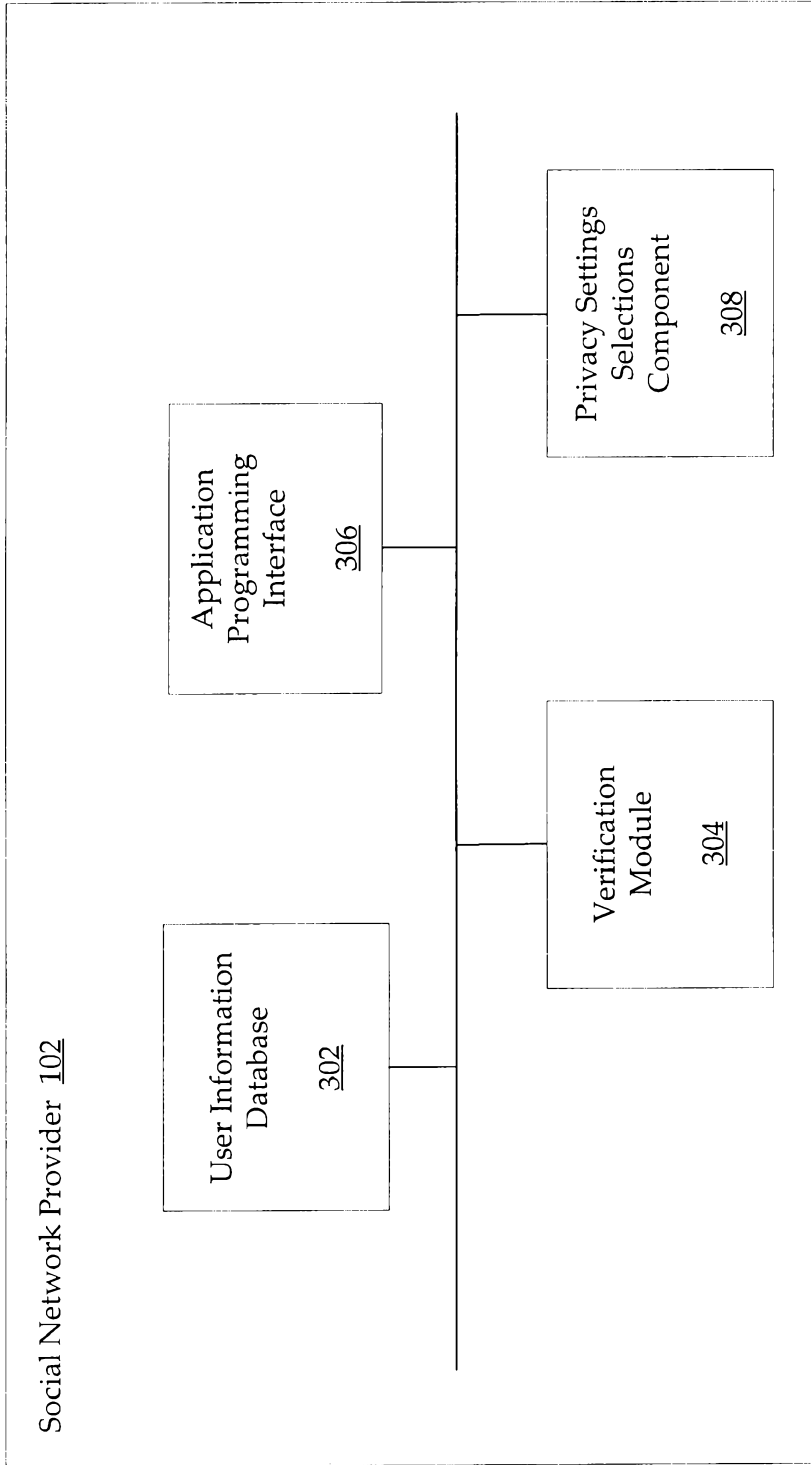

FIG. 3

# MoochSpot

- Log In
- About

Welcome to MoochSpot!

You can use MoochSpot to keep track of debts and shared expenses with your friends.

Splitting a power bill with your roommate? Ordering a stack of pizzas for your Wednesday night poker game? Lending fifty bucks to your little brother? Keep track of it here and stop worrying about who you owe and who owes you. You can even pay your friends using PayPal!



Log in using your Facebook account and get started right away!

© 2006 Facebook

400

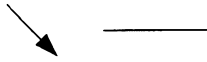

402

FIG. 4

# MoochSpot

- Home
- Settings
- Log Out
- About

- Mooch Spot
- Settle Debts

500



## Latest News

**MoochSpot now supports PayPal payments!** Click on the "Settings" link at the top of the page and enter your PayPal E-mail address. (We will never use that address to send you spam.) Then your friends can spot you money or settle their debts to you online.

502 ~ **Brian's Piggy Banks: Create a new Piggy Bank**

You are not a member of any Piggy Banks yet. Create one and invite your friends!

504

To learn more about Piggy Banks and how they can save you lots of time and hassle, have a look at the About page!

506 ~ **Brian's recent activity:**

You don't have any activity yet. Mooch or spot some money and you'll see your transactions listed here.

FIG. 5