

[54] **SHIELDED WIRE CONNECTORS**

[72] Inventor: **William Joseph Garver, Harrisburg, Pa.**

[73] Assignee: **AMP Incorporated, Harrisburg, Pa.**

[22] Filed: **Aug. 20, 1970**

[21] Appl. No.: **65,462**

[52] U.S. Cl. .... **339/177 MP, 339/143 R, 339/223 R, 339/276 T**

[51] Int. Cl. .... **H01r 17/18**

[58] Field of Search. .... **339/220, 213, 212, 177, 223, 339/276, 143, 176; 174/75 C, 78**

[56] **References Cited**

**UNITED STATES PATENTS**

3,474,385	10/1969	Cefarelli et al. ....	339/47
3,295,094	12/1966	De Lyon et al. ....	339/177
3,112,150	11/1963	Hammell ....	339/276
2,954,420	9/1960	Logan ....	174/75 C
2,157,007	5/1939	Offner ....	339/223

**FOREIGN PATENTS OR APPLICATIONS**

1,154,850	9/1963	Germany.....	339/177 R
-----------	--------	--------------	-----------

1,258,320	3/1961	France.....	339/276
401,198	4/1966	Switzerland.....	339/97 C

*Primary Examiner*—Richard E. Moore

*Assistant Examiner*—Robert A. Hafer

*Attorney*—William J. Keating, Ronald D. Grefe, Gerald K. Kita, Frederick W. Raring, Jay L. Seitchik and John P. Vandenburg

[57] **ABSTRACT**

A shielded cable electrical connector is provided with a coaxial contact section having inner and outer contact members separated from each other by a dielectric means which carries the inner contact member. The outer contact member is provided with axially-spaced ferrule means coaxially aligned with ferrule member means of the inner contact member extending outwardly from the dielectric means. One of the axially-spaced ferrule means has a first section of substantially annular construction and a second section extending substantially tangentially outwardly from the first section so that a drain or ground wire of a shielded cable can be crimped between the first and second sections while a center conductor of the cable is crimped in the ferrule member means of the inner contact member.

**5 Claims, 11 Drawing Figures**

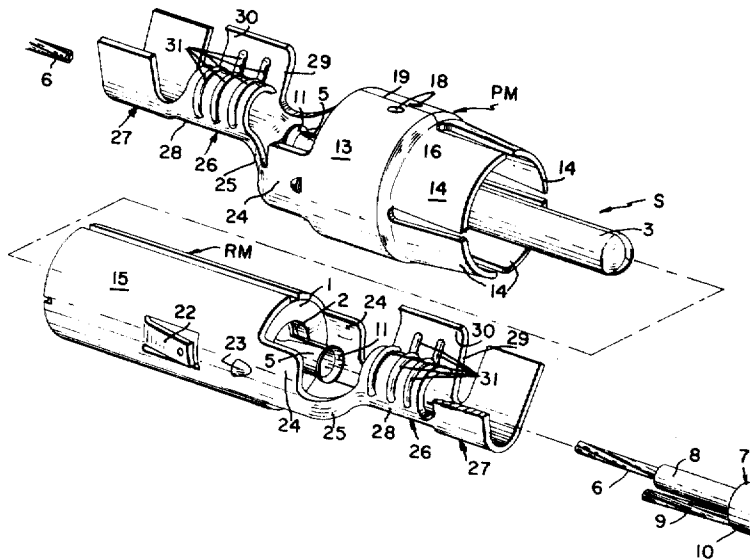

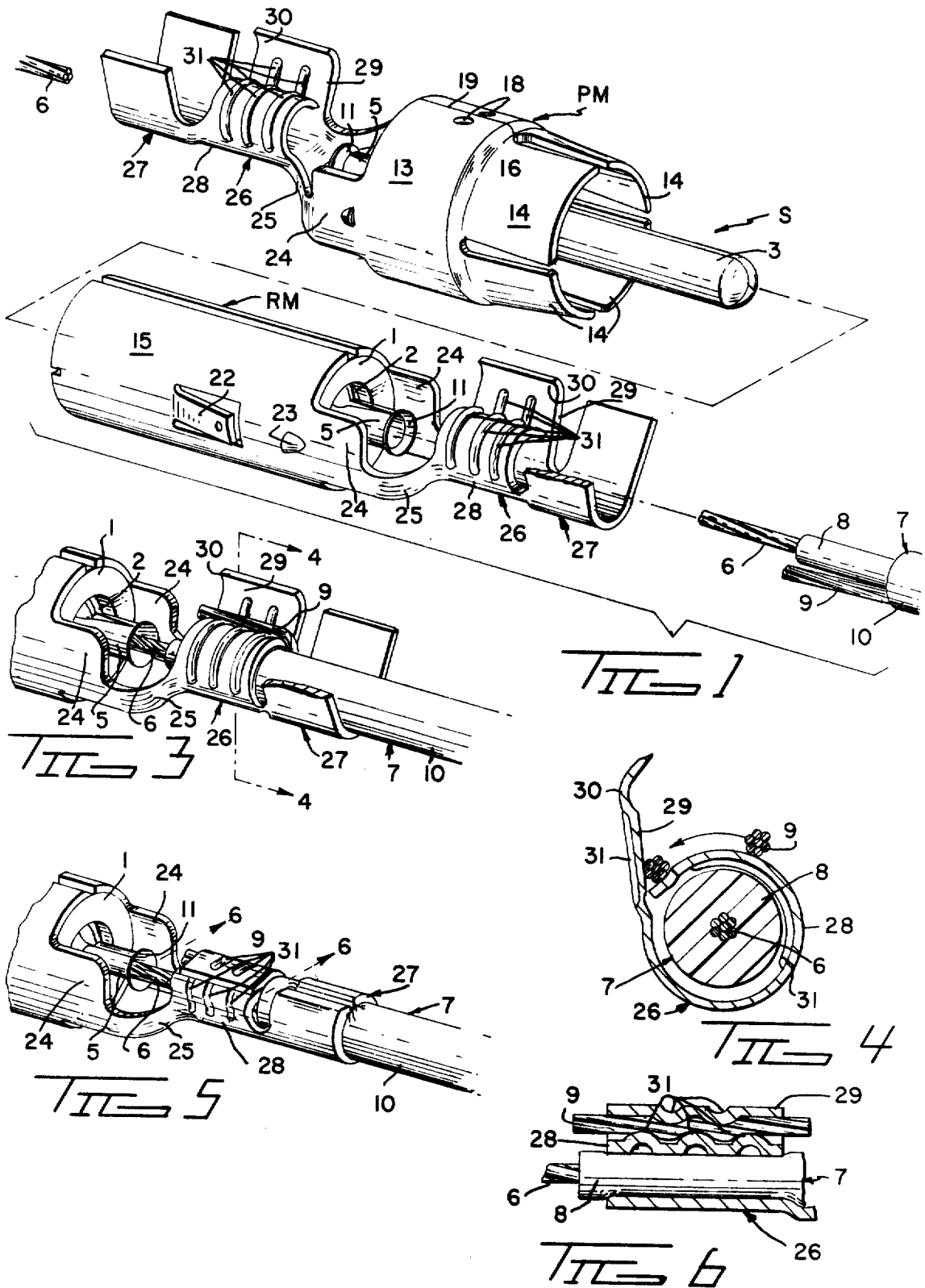

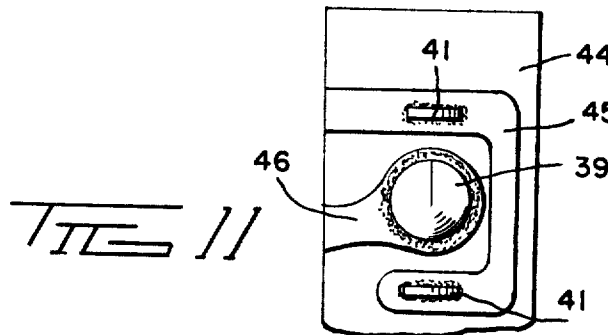
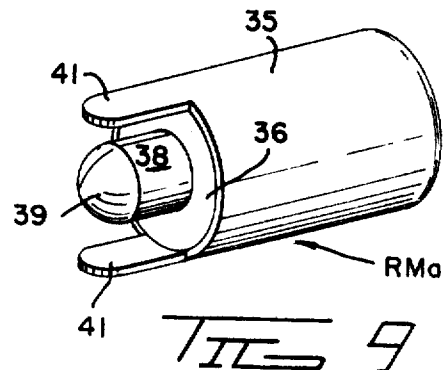
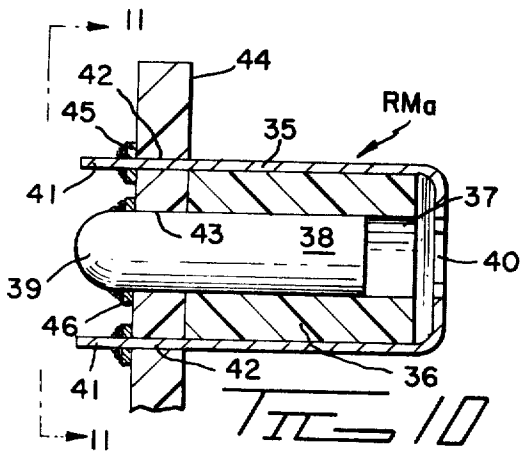
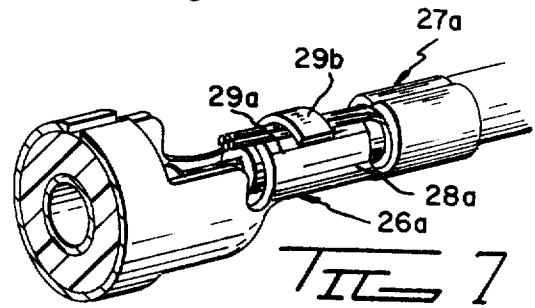
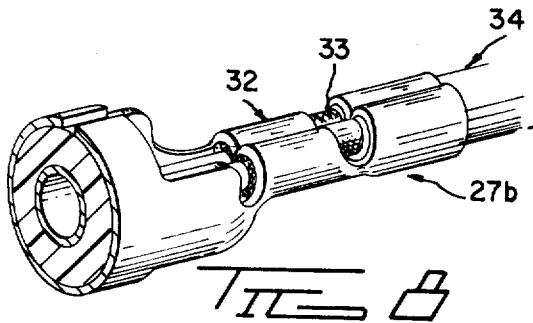
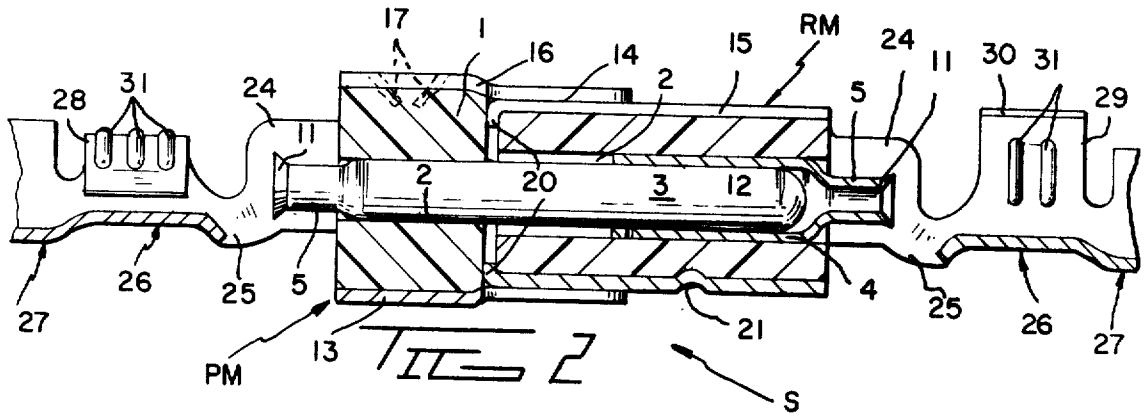

## SHIELDED WIRE CONNECTORS

## BACKGROUND OF THE INVENTION

Shielded cable is used for many applications in instrumentation, strain gauge, audio, video and data transmission equipment. Many ways have been developed to terminate ends of the shielded cable to electrical connectors. One way is to solder the shield and the center conductor of the shielded cable to insulatively-spaced coaxial contact members. Another way is to crimp the shield and center conductor within the coaxial contact members as taught by U.S. Pat. No. 3,295,094.

The drawback of this patent is the large amount of center conductor that has to be stripped so that this conductor can be crimped within an outer end of the center contact member and the large spacing between the crimping of the center contact member and the outer contact member respectively to the outer and inner conductors of the shielded cable. Another drawback of the patent and heretofore teachings is the fact that the end of the shielded cable is terminated to a plug and not to a receptacle.

An object of the present invention is to provide shielded cable electrical connector means of the mateable plug and receptacle variety.

Another object is the provision of shielded cable electrical connector means which has closely spaced crimping areas provided by the center and outer contact members.

A further object is to provide ferrule means on the shielded cable electrical connector means for crimping between sections thereof adapted to be overlapped a ground or drain wire of a shielded cable.

An additional object is the provision of cooperating serration means on the sections to be overlapped to form the part of the ground or drain wire when crimped therebetween into an undulating configuration.

Still a further object is to provide shielded cable electrical connector means having other ferrule means for crimping onto an outer insulation sheath of the shielded cable to provide strain relief.

Other objects and attainments of the present invention will become apparent to those skilled in the art upon a reading of the following detailed description when taken in conjunction with the drawings in which there are shown and described illustrative embodiments of the invention; it is to be understood, however, that these embodiments are not intended to be exhaustive nor limiting of the invention but are given for purposes of illustration and principles thereof and the manner of applying them in practical use so that they may modify them in various forms, each as may be best suited to the conditions of a particular use.

## BRIEF DESCRIPTION OF THE DRAWINGS

FIG. 1 is a perspective and exploded view of mateable shielded cable electrical connector means and stripped ends of shielded cable means;

FIG. 2 is a longitudinal cross-sectional view of the electrical connector means of FIG. 1 in a mated condition but not crimped onto the stripped ends of the shielded cable means;

FIG. 3 is a part perspective view of the crimping areas of either of the plug or receptacle members of the electrical connector means with the stripped end of the shielded cable means in position therein prior to being crimped;

FIG. 4 is a view taken along lines 4—4 of FIG. 3;

FIG. 5 is a view similar to FIG. 3 illustrating a crimped connection;

FIG. 6 is a view taken along lines 6—6 of FIG. 5;

FIG. 7 is a part perspective view of another embodiment;

FIG. 8 is a part perspective view of a further embodiment;

FIG. 9 is a perspective view of an additional embodiment;

FIG. 10 is a cross-sectional view of FIG. 9 in position on a printed circuit board; and

FIG. 11 is a view taken along lines 11—11 of FIG. 10.

## DESCRIPTION OF PREFERRED EMBODIMENTS

FIGS. 1 - 6 illustrate a shielded cable electrical connector means S which comprises a plug member PM and a receptacle member RM.

Each plug and receptacle member has an annular dielectric member 1 which is provided with a central hole 2. An inner metallic member in the form of a pin 3 is disposed in hole 2 of dielectric member 1 of plug member PM while a receptacle 4 is disposed in hole 2 of dielectric member 1 of receptacle member RM. Dielectric members 1 can be made of polyvinyl chloride, polypropylene, or other suitable material. The inner metallic members, pin 3 and receptacle 4, have tubular crimping areas or ferrule members 5 for receiving therein center conductors 6 of braided cable means 7. An inner insulating sheath 8 surrounds conductor 6 and drain or ground wire 9 extends along insulation 8 with a metallic plastic shield (not shown) in electrical engagement with wire 9. An outer insulation sheath 10 provides the outer covering for the cable. Crimping areas 5 have beveled or flared entrances 11 to facilitate movement of center conductors 6 thereinto. Receptacle 4 is provided with a spring tab 12 to enable pin 3 and receptacle 4 to form a good tight electrical connection when pin 3 and receptacle 4 engage each other.

Plug member PM has an outer metallic conductor 13 formed into intimate engagement with dielectric member 1 and it is provided with arcuate-shaped contact-engaging members 14 which extend outwardly from dielectric member 1 and axially along pin 3 as well as extending slightly inwardly towards pin 3 so as to make proper electrical engagement with outer metallic conductor 15 of receptacle member RM via spring engagement created by the spring characteristics of members 14.

As can be discerned, a bent area 16 is provided at inner ends of members 14 to limit inner movement of dielectric member 1, and inwardly-directed projections 17, which are formed when holes 18 are made and are located on each side of seam 19, lock dielectric member 1 in position. Formation of outer conductor 13 tightly around dielectric member 1 causes projections 17 to penetrate the dielectric member and coaxially positions pin 3 relative to outer conductor 3 and contact-engaging members 14.

Outer conductor 15 of receptacle member RM is tightly formed around dielectric member 1 from one end to the other thereof. Inwardly-directed projections 20 are located at the front end of outer conductor 15 to limit inner movement of dielectric member 1 and an indent 21 is formed in the outer conductor to limit rearward movement of the dielectric member.

Spring lances 22 and detents 23 are provided by outer conductor 15 to enable the receptacle member to be removably mounted in a suitable housing if desired.

Both outer conductors 13 and 15 have diametrical wings 24 extending rearwardly therefrom in a substantially parallel manner relative to tubular-crimping areas 5 and they include transition sections 25 which meet at a central location thereby forming first and second ferrule forming sections 26, 27, which collectively constitute a cable attaching portion. Wings 24 and transition sections 25 provide protection to crimping areas 5 to protect them from being deformed.

Ferrule member 26 has a tubular section 28 and a tangential section 29 which has an arcuately-shaped free end 30. The tubular section 28 and the tangential section 29 in effect are sidewalls which extend from a bight which runs along the length of the connector. In its uncrimped condition, ferrule member 26 has a b-shaped or a figure 9 shaped configuration in cross-section depending on which way you look at it. Axially-spaced serrations 31 are located in sections 28 and 29 which cooperate when section 29 is moved into overlapping engagement with section 28 when drain wire 9 is crimped therebetween to form drain wire 9 in this crimping area into an undulating configuration as illustrated by FIG. 6 which

breaks down any oxide coating to form an excellent electrical connection and to increase tensile strength of the connection.

Wire 9 is moved against section 29 to position it between sections 28 and 29 as illustrated in FIG. 4 so that the wire can be properly crimped therebetween. Arcuately-shaped free end 30 snugly engages section 28 when section 29 is bent thereagainst.

Ferrule member 27 is U-shaped in cross-section and its legs are bent around sheath 10 to increase the pull out strength of the connection thereby strengthening the connection.

As can be discerned, crimping ferrule members 5, 26 and 27 are coaxially aligned so that the stripped center conductor 6, insulation 8 and sheath 10 are respectively positioned at the juncture between sections 28 and 29 whereupon controlled crimping pressure is applied simultaneously to ferrule members 5, 26 and 27 by crimping dies (not shown) thereby effectively crimping these ferrule members to conductor 6, drain wire 9 and sheath 10 to form an excellent electrical and mechanical connection or termination.

The open area on opposite sides of ferrule member 5 and between wings 24 enable ferrule member 5 to be readily crimped.

FIG. 7 is another embodiment and illustrates section 29a of ferrule member 26a having a tab 29b formed therefrom and which is crimped onto wire 9 and against section 29a. In FIGS. 1 - 6, section 29 is the same length as section 28 whereas tab 29b is only about one-third the length of section 28a; neither has serrations, but they can be provided if desired, otherwise, the connector of FIG. 7 is the same as that of FIGS. 1 - 6.

Ferrule member 32 of FIG. 8 is similar in construction as ferrule member 27b and it is controllably crimped onto shield braid 33 of cable means 34 instead of onto a drain wire as heretofore described. Otherwise, the connector of FIG. 8 is the same as that of FIGS. 1 - 6.

FIGS. 9 - 11 illustrate receptacle member RMa which comprises a tubular outer conductor 35 having a dielectric insert 36 positioned therein and carrying in a central hole 37 thereof a receptacle 38 which extends outwardly from insert 36 and has a rounded end 39. An aperture 40 is provided in conductor 35 in axial alignment with hole 37 and receptacle 38. Legs 41 extend outwardly from conductor 35 on opposite sides of rounded end 39 and substantially parallel thereto. The free ends of legs 41 are rounded.

Legs 41 and rounded end 39 extend through slots 42 and hole 43 respectively in printed circuit board 44, and they are soldered via flow-soldering techniques to conductive paths 45 and 46 thereon. The rounded end 39 of receptacle 38 prevents any wicking of solder onto the inside of receptacle 38 to impede seating of pin 3 of plug member PM therein while contact-engaging members 14 springably engage conductor 35. Receptacle 38 can be provided with a spring tab 12 in the manner of receptacle 4 to assure good electrical connection with pin 3. Thus, receptacle member RMa provides an excellent connector for connection with a plug member terminated to a shielded cable.

It will, therefore, be appreciated that the aforementioned and other desirable objects have been achieved; however, it should be emphasized that the particular embodiments of the invention, which are shown and described herein are intended as merely illustrative and not as restrictive of the invention.

The invention is claimed in accordance with the following:

1. An electrical connecting device for a shielded cable of the type comprising a center conductor, an inner insulating sheath in surrounding relationship to said center conductor, an outer insulating sheath in surrounding relationship to said inner insulating sheath, and metallic shielding comprising a drain wire between said inner and outer insulating sheaths, said connecting device comprising:

an outer metallic member, said outer member having a cylindrical contact portion and having a cable attaching portion integral therewith and extending from one end thereof,

an inner metallic member coaxially disposed within said outer metallic member, said inner metallic member being adapted to receive said center conductor and being insulated from said outer metallic member,

5 said cable attaching portion comprising first and second ferrule forming sections, said first ferrule-forming section comprising an arcuate bight and sidewalls extending from said bight, one of said sidewalls extending generally tangentially from said bight, the other one of said sidewalls extending from said bight along an arcuate path towards said one sidewall, said other sidewall having a longitudinally extending edge which is adjacent to said one sidewall and spaced inwardly from the longitudinal edge of said one sidewall,

15 said second ferrule forming portion being generally U-shaped and being in alignment with said first ferrule forming portion, whereby,

upon locating an end portion of said cable in said connecting device with an exposed portion of said center conductor in said inner metallic member, with an exposed portion of said inner insulating sheath between said sidewalls of said first ferrule forming portion and partially surrounded by said other sidewall thereof, and with an exposed portion of said drain wire adjacent the inner and outer surfaces of said one sidewall and said other sidewall respectively, and with an unstripped portion of said cable within said U-shaped second ferrule forming section, and upon crimping said first and second ferrule forming sections onto said cable, said outer metallic member is electrically connected in an electrical connection to said drain wire by said first ferrule forming portion, and said outer metallic member is mechanically connected to said outer insulating sheath with a mechanical connection which is independent of said electrical connection.

2. A connecting device as set forth in claim 1 wherein said first and second sidewalls of said first ferrule forming section have transversely extending serrations therein, the serrations in said first sidewall being axially offset relative to the serrations in said second sidewall whereby, said drain wire is formed into an undulating configuration between said sidewalls upon crimping.

3. A connecting device as set forth in claim 2, said connecting device comprising a plug member, said inner metallic member comprising a contact pin.

4. A connecting device as set forth in claim 2, said connecting device comprising a socket member, said inner metallic member comprising a contact socket.

5. An electrical connecting device on one end of a shielded cable, said cable being of the type comprising a center conductor, an inner insulating sheath in surrounding relationship to said center conductor, an outer insulating sheath in surrounding relationship to said inner insulating sheath, and metallic shielding comprising a drain wire between said inner and outer insulating sheaths, said connecting device comprising:

inner and outer metallic members, said outer metallic member comprising a cylindrical contact portion and said inner metallic member comprising a cylindrical contact portion coaxially disposed in said outer metallic member, a cable attaching portion integral with, and extending from, said outer metallic member at one end thereof, said cable attaching portion comprising first and second ferrule sections, said first ferrule section being proximate to said outer metallic member and said second ferrule section being remote from said outer metallic member, said one end of said cable being selectively stripped to expose said center conductor at said one end and to expose said drain wire and said inner insulating sheath adjacent to said one end,

said inner conductor extending into said inner metallic member,

said first ferrule section comprising a bight and sidewall, said first ferrule section being crimped to a circular configuration with one of said sidewalls having overlapping

5

portions which overlap the other one of said sidewalls, said bight and said other sidewall being in constrictive embracing relationship to said inner insulating sheath, said drain wire being crimped between said other sidewall and said overlapping portions of said one sidewall, and said second ferrule section being crimped onto said outer insulating sheath whereby,

6

said center conductor is electrically connected to said inner metallic member, said drain wire is electrically connected to said outer metallic member, and said outer insulating sheath is mechanically connected to said outer metallic member with a crimped connection which is independent of said drain wire connection to said outer metallic member.

\* \* \* \* \*

10

15

20

25

30

35

40

45

50

55

60

65

70

75