

(19) AUSTRALIAN PATENT OFFICE

- (54) Title
Pump assembly for a print engine
- (51) ⁶ International Patent Classification(s)
B41J 002/165
- (21) Application No: 2004203191 (22) Application Date: 2004.07.15
- (43) Publication Date : 2004.08.12
- (43) Publication Journal Date : 2004.08.12
- (62) Divisional of:
2000253735
- (71) Applicant(s)
Silverbrook Research Pty Ltd
- (72) Inventor(s)
Jackson, Garry Raymond; Silverbrook, Kia; King, Tobin
Allen 7
- (74) Agent/Attorney
Silverbrook Research Pty Ltd, 393 Darling Street, Balmain, NSW,
2041
- (56) Related Art
US 5559538
JP 01-082962
US 5379999
GB 2280149
US 5184147
EP 765751
JP 07-009680

ABSTRACT

A pump assembly for a print engine, the print engine having a printhead employing an arrangement for fluid cleaning of the printhead, the pump assembly including: a housing defining a fluid inlet and a fluid outlet; an impeller configured for drawing fluid through the inlet, and for ejecting the fluid through the outlet to effect said fluid cleaning of the printhead;
5 inlet, and for ejecting the fluid through the outlet to effect said fluid cleaning of the printhead;
and a drive means for rotatably driving the impeller, the drive means further controlling feeding of print media to the printhead for printing of an image on the print media.

Figure 1

10

CPE15-AU

PUMP ASSEMBLY FOR A PRINT ENGINE

Field of the Invention

This invention relates to a print engine. The invention has particular application in a
5 print engine for use in an instantaneous print, digital camera. More particularly, the invention
relates to a pump assembly for a print engine.

Background to the Invention

The page width printhead of the present invention uses a nozzle guard through which
10 ink droplets are ejected. It is important to maintain the nozzle guard free of foreign particles
and detritus so that the ink is not contaminated by such foreign matter and
microelectromechanical systems (MEMS) ink ejection devices are not blocked by the foreign
matter. One of the simplest ways of achieving this is to blow out over a surface of the nozzle
guard and a zone between the nozzle guard and that surface of a silicon wafer of the printhead
15 carrying the MEMS devices.

By "page width" is meant that the printhead prints one line at a time on the print media
without traversing the print media, or rastering, as the print media moves past the printhead.

In addition, it is desirable to make the print engine as compact as possible in order to
reduce the size of the camera in which the print engine is employed.

20

Summary of the Invention

According to the invention, there is provided a pump assembly for a print engine, the
print engine having a printhead employing an arrangement for fluid cleaning of the printhead,
the pump assembly including:

25 a housing defining a fluid inlet and a fluid outlet;

an impeller configured for drawing fluid through the inlet, and for ejecting the fluid
through the outlet to effect said fluid cleaning of the printhead; and

a drive means for rotatably driving the impeller, the drive means being a drive means of
the print engine, which controls feeding of print media to the printhead for printing of an image
30 on the print media.

CPE15-AU

The inlet may communicate with a filter means, which filters the fluid, via a coupling device in the form of an air inlet pin. It is envisaged that the filter means will be incorporated in a print cartridge to be replaced when the print cartridge is replaced such that air blown over the printhead by the pump assembly is filtered prior to being ejected from the pump assembly.

5 The pump may include a housing in which the impeller is rotatably mounted, a part of the housing being defined by a chassis which supports the coupling device and which defines a fluid supply path which supplies the fluid to the printhead.

The drive means may be a drive motor connected to the impeller by a first gear arrangement and to a feed means of a print roll of a print cartridge of the print engine via a
10 second gear arrangement. Preferably, the drive motor is a stepper motor so that air is supplied to the printhead only when the printhead is operational.

Brief Description of the Drawings

The invention will now be described by way of example with reference to the
15 accompanying diagrammatic drawings in which:-

Figure 1 shows a three dimensional view of a print engine, including components in accordance with the invention;

Figure 2 shows a three dimensional, exploded view of the print engine;

20 Figure 3 shows a three dimensional view of the print engine with a removable print cartridge used with the print engine removed;

Figure 4 shows a three dimensional, rear view of the print engine with the print cartridge shown in dotted lines;

Figure 5 shows a three dimensional, sectional view of the print engine;

25 Figure 6 shows a three dimensional, exploded view of a printhead sub-assembly of the print engine;

Figure 7 shows a partly cutaway view of the printhead sub-assembly;

Figure 8 shows a sectional end view of the printhead sub-assembly with a capping mechanism in a capping position;

30 Figure 9 shows the printhead sub-assembly with the capping mechanism in its uncapped position; and

CPE15-AU

Figure 10 shows an exploded, three dimensional view of an air supply arrangement of the print engine.

5 **Detailed Description of the Drawings**

In the drawings, reference numeral 500 generally designates a print engine, in accordance with the invention. The print engine 500 includes a print engine assembly 502 on which a print roll cartridge 504 is removably mountable.

10 The print cartridge 504 is described in greater detail in our co-pending applications entitled "A Print Cartridge" (docket number CA02) and "An Ink Cartridge" (docket number CA04) filed simultaneously herewith as International Patent Application numbers PCT/AU00/00741 and PCT/AU00/00742 respectively, the contents of that disclosure being specifically incorporated herein by reference.

15 The print engine assembly 502 comprises a first sub-assembly 506 and a second, printhead sub-assembly 508.

The sub-assembly 506 includes a chassis 510. The chassis 510 comprises a first molding 512 in which ink supply channels 514 are molded. The ink supply channels 514 supply inks from the print cartridge 504 to a printhead 516 (Figures 5 to 7) of the printhead sub-assembly 508. The printhead 516 prints in four colors or three colors plus ink which is visible in the infrared light spectrum only (hereinafter referred to as 'infrared ink'). Accordingly, four ink supply channels 514 are defined in the molding 512 together with an air supply channel 518. The air supply channel 518 supplies air to the printhead 516 to inhibit the build up of foreign particles on a nozzle guard of the printhead 516.

25 The chassis 510 further includes a cover molding 520. The cover molding 520 supports a pump 522 thereon. The pump 522 is a suction pump, which draws air through an air filter in the print cartridge 504 via an air inlet pin 524 and an air inlet opening 526. Air is expelled through an outlet opening 528 into the air supply channel 518 of the chassis 510.

30 The chassis 510 further supports a first drive motor in the form of a stepper motor 530. The stepper motor 530 drives the pump 522 via a first gear train 532. The stepper motor 530 is also connected to a drive roller 534 (Figure 5) of a roller assembly 536 of the print cartridge 504 via a second gear train 538. The gear train 538 engages an engagable element 540 (Figure

CPE15-AU

2) carried at an end of the drive roller 534. The stepper motor 530 thus controls the feed of print media 542 to the printhead 516 of the sub-assembly 508 to enable an image to be printed on the print media 542 as it passes beneath the printhead 516. It also to be noted that, as the stepper motor 530 is only operated to advance the print media 542, the pump 522 is only
5 operational to blow air over the printhead 516 when printing takes place on the print media 542.

The molding 512 of the chassis 510 also supports a plurality of ink supply conduits in the form of pins 544 which are in communication with the ink supply channels 514. The ink supply pins 544 are received through an elastomeric collar assembly 546 of the print cartridge
10 504 for drawing ink from ink chambers or reservoirs 548 (Figure 5) in the print cartridge 504 to be supplied to the printhead 516.

A second motor 550, which is a DC motor, is supported on the cover molding 520 of the chassis 510 via clips 552. The motor 550 is provided to drive a separating means in the form of a cutter arm assembly 554 to part a piece of the print media 542, after an image has been
15 printed thereon, from a remainder of the print media. The motor 550 carries a beveled gear 556 on an output shaft thereof. The beveled gear 556 meshes with a beveled gear 558 carried on a worm gear 560 of the cutter assembly 554. The worm gear 560 is rotatably supported via bearings 562 in a chassis base plate 564 of the printhead sub-assembly 508.

The cutter assembly 554 includes a cutter wheel 566, which is supported on a resiliently
20 flexible arm 568 on a mounting block 570. The worm gear 560 passes through the mounting block 570 such that, when the worm gear 560 is rotated, the mounting block 570 and the cutter wheel 566 traverse the chassis base plate 564. The mounting block 570 bears against a lip 572 of the base plate 564 to inhibit rotation of the mounting block 570 relative to the worm gear 560. Further, to effect cutting of the print media 542, the cutter wheel 566 bears against an
25 upper housing or cap portion 574 of the printhead sub-assembly 508. This cap portion 574 is a metal portion. Hence, as the cutter wheel 566 traverses the capped portion 574, a scissors-like cutting action is imparted to the print media to separate that part of the print media 542 on which the image has been printed.

The sub-assembly 506 includes an ejector mechanism 576. The ejector mechanism 576
30 is carried on the chassis 510 and has a collar 578 having clips 580, which clip and affix the ejector mechanism 576 to the chassis 510. The collar 578 supports an insert 582 of an

elastomeric material therein. The elastomeric insert 582 defines a plurality of openings 584. The openings 584 close off inlet openings of the pins 544 to inhibit the ingress of foreign particles into the pins 544 and, in so doing, into the channels 514 and the printhead 516. In addition, the insert 584 defines a land or platform 586 which closes off an inlet opening of the
5 air inlet pin 524 for the same purposes.

A coil spring 588 is arranged between the chassis 510 and the collar 578 to urge the collar 578 to a spaced position relative to the chassis 510 when the cartridge 504 is removed from the print engine 500, as shown in greater detail in Figure 3 of the drawings. The ejector mechanism 576 is shown in its retracted position in Figure 4 of the drawings.

10 The printhead sub-assembly 508 includes, as described above, the base plate 564. A capping mechanism 590 is supported displaceably on the base plate 564 to be displaceable towards and away from the printhead 516. The capping mechanism 590 includes an elongate rib 592 arranged on a carrier 593. The carrier is supported by a displacement mechanism 594, which displaces the rib 592 into abutment with the printhead 516 when the printhead 516 is
15 inoperative. Conversely, when the printhead 516 is operational, the displacement mechanism 594 is operable to retract the rib 592 out of abutment with the printhead 516.

The printhead sub-assembly 508 includes a printhead support molding 596 on which the printhead 516 is mounted. The molding 596, together with an insert 599 arranged in the molding 596, defines a passage 598 through which the print media 542 passes when an image
20 is to be printed thereon. A groove 700 is defined in the molding 596 through which the capping mechanism 590 projects when the capping mechanism 590 is in its capping position.

An ink feed arrangement 702 is supported by the insert 599 beneath the cap portion 574. The ink feed arrangement 702 comprises a spine portion 704 and a casing 706 mounted on the spine portion 704. The spine portion 704 and the casing 706, between them, define ink feed
25 galleries 708 which are in communication with the ink supply channels 514 in the chassis 510 for feeding ink via passages 710 (Figure 7) to the printhead 516.

An air supply channel 711 (Figure 8) is defined in the spine portion 704, alongside the printhead 516.

Electrical signals are provided to the printhead 516 via a TAB film 712 which is held
30 captive between the insert 599 and the ink feed arrangement 702.

CPE15-AU

The molding 596 includes an angled wing portion 714. A flexible printed circuit board (PCB) 716 is supported on and secured to the wing portion 714. The flex PCB 716 makes electrical contact with the TAB film 712 by being urged into engagement with the TAB film 712 via a rib 718 of the insert 599. The flex PCB 716 supports busbars 720 thereon. The busbars 720 provide power to the printhead 516 and to the other powered components of the print engine 500. Further, a camera print engine control chip 721 is supported on the flex PCB 716 together with a QA chip (not shown) which authenticates that the cartridge 504 is compatible and compliant with the print engine 500. For this purpose, the PCB 716 includes contacts 723, which engage contacts 725 in the print cartridge 504.

10 As illustrated more clearly in Figure 7 of the drawings, the printhead itself includes a nozzle guard 722 arranged on a silicon wafer 724. The ink is supplied to a nozzle array (not shown) of the printhead 516 via an ink supply member 726. The ink supply member 726 communicates with outlets of the passages 710 of the ink feed arrangement 702 for feeding ink to the array of nozzles of the printhead 516, on demand.

15 In Figure 10, the air supply path for supplying air to the printhead 516 is shown in greater detail. As illustrated, the pump 522 includes an impeller 728 closed off by an end cap 730. The cover molding 520 of the chassis forms a receptacle 732 for the impeller 728. The cover molding 520 has the air inlet opening 734 and the air outlet opening 736. The air inlet opening 734 communicates with the pin 524. The air outlet opening 736 feeds air to the air supply channel 518 which, in Figure 10, is shown as a solid black line. The air fed from the air supply channel 518 is blown into the printhead 516 to effect cleaning of the printhead. The air drawn in via the pump 522 is filtered by an air filter 738, which is accommodated in the print cartridge 504. The air filter 738 has a filter element 740 which may be paper based or made of some other suitable filtering media. The filter element 740 is housed in a canister, having a base 742 and a lid 744. The lid 744 has an opening 746 defined therein. The opening 746 is closed off by a film 748 which is pierced by the pin 524. The advantage of having the air filter 738 in the print cartridge 504 is that the air filter 738 is replaced when the print cartridge 504 is replaced.

20 It is an advantage of the invention that an air pump 522 is driven by the stepper motor 530, which also controls feed of the print media to the printhead 516. In so doing, fewer components are required for the print engine 500 rendering it more compact. In addition, as

CPE15-AU

the same motor 530 is used for operating the air pump 522 and for feeding the print media 542 to the printhead 516, fewer power consuming components are included in the print engine 500 rendering it more compact and cheaper to produce.

5 It is also to be noted that, in order to make the print engine 500 more compact, the size of the print engine assembly 502 is such that most of the components of the assembly 502 are received within a footprint of an end of the print cartridge 504.

10 It will be appreciated by persons skilled in the art that numerous variations and/or modifications may be made to the invention as shown in the specific embodiments without departing from the spirit or scope of the invention as broadly described. The present embodiments are, therefore, to be considered in all respects as illustrative and not restrictive.

Claims:

1. A pump assembly for a print engine, the print engine having a printhead employing an arrangement for fluid cleaning of the printhead, the pump assembly including:
 - 5 a housing defining a fluid inlet and a fluid outlet;
 - an impeller configured for drawing fluid through the inlet, and for ejecting the fluid through the outlet to effect said fluid cleaning of the printhead; and
 - a drive means for rotatably driving the impeller, the drive means further controlling feeding of print media to the printhead for printing of an image on the print media;
 - 10 wherein the inlet communicates with a filter means, which filters the fluid, via a coupling device, and wherein the pump includes a housing in which the impeller is rotatably mounted, a part of the housing being defined by a chassis which supports the coupling device and which defines a fluid supply path which supplies the fluid to the printhead.
- 15 2. The pump assembly of claim 1 in which the drive means is a drive motor connected to the impeller by a first gear arrangement and to a feed means of a print roll of a print cartridge of the print engine via a second gear arrangement.
3. The pump assembly of claim 2 in which the drive motor is a stepper motor so that fluid
20 is supplied to the printhead only when the printhead is operational.
4. A pump assembly as claimed in claim 1 wherein the fluid is air.

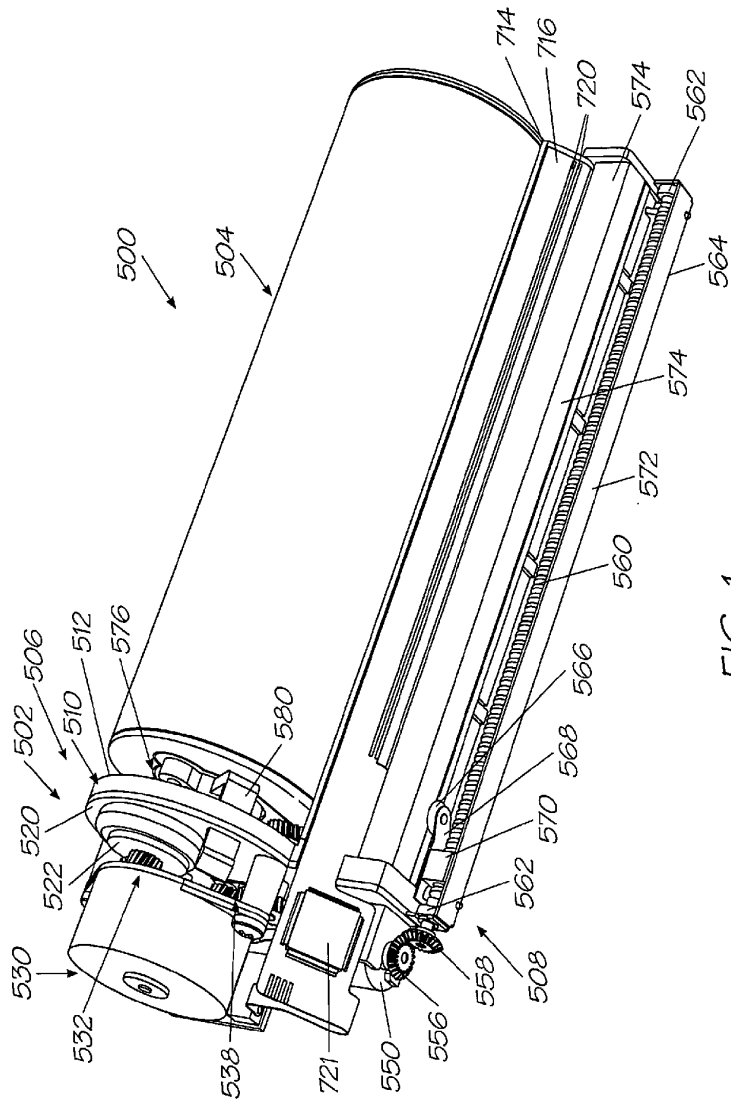

FIG. 1

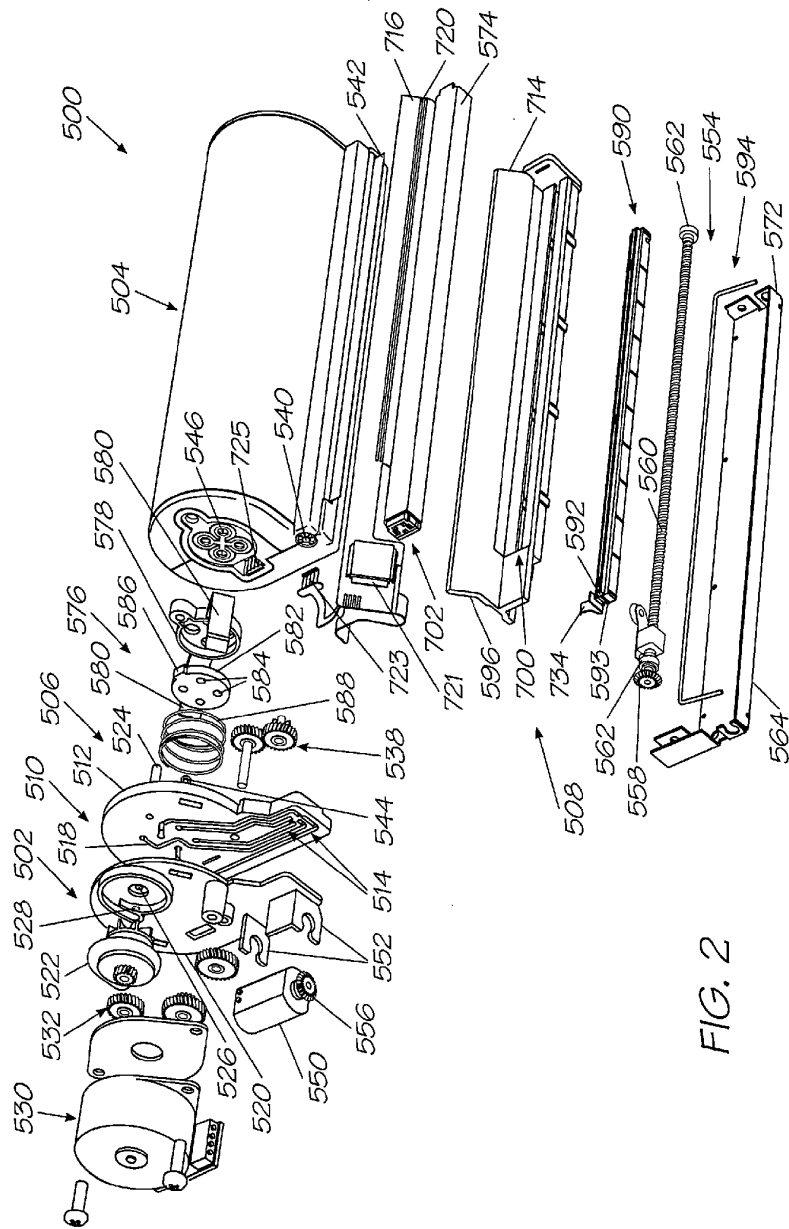

FIG. 2

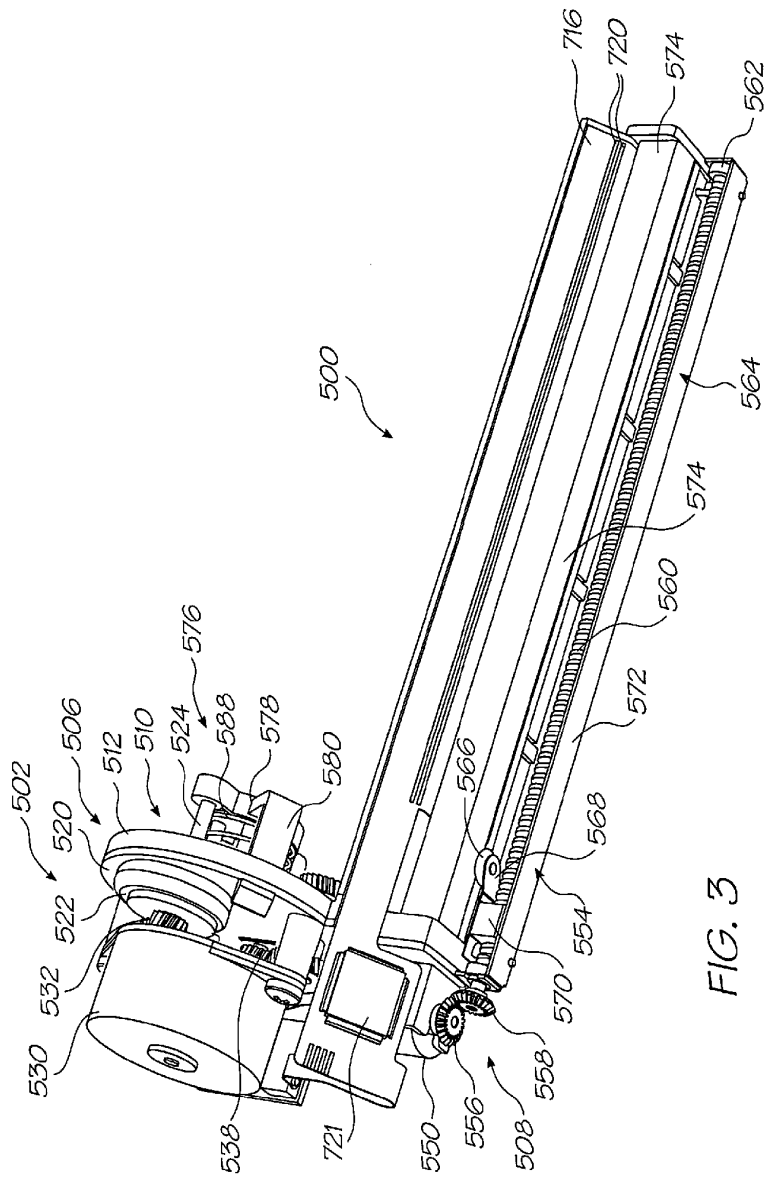

FIG. 3

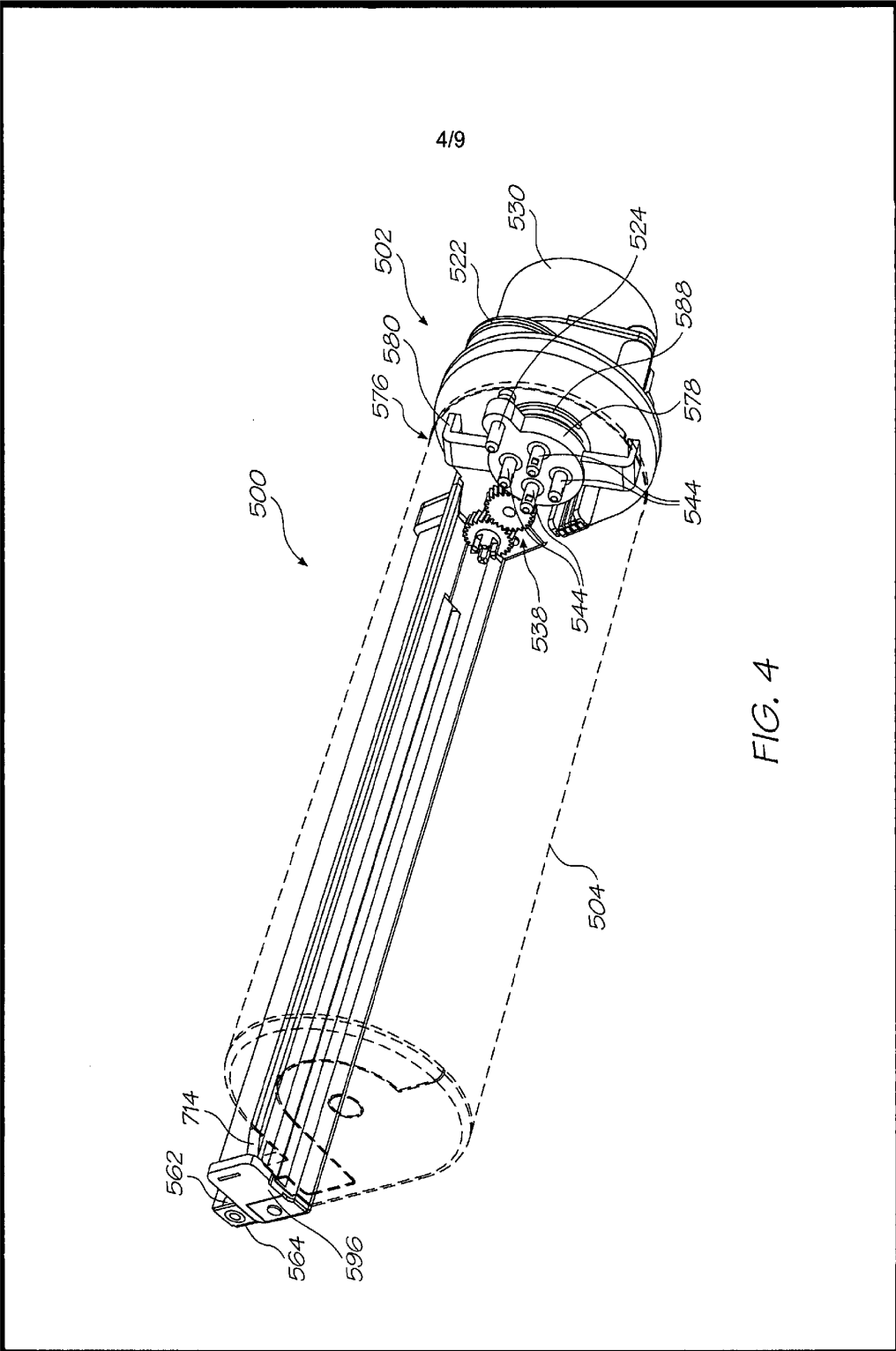

FIG. 4

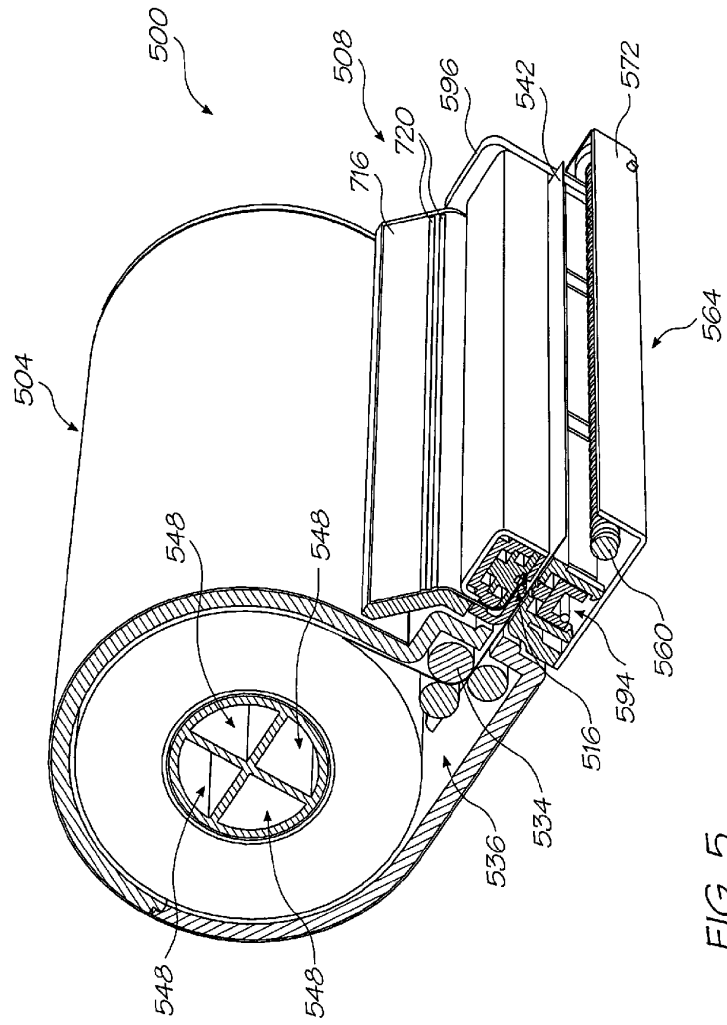

FIG. 5

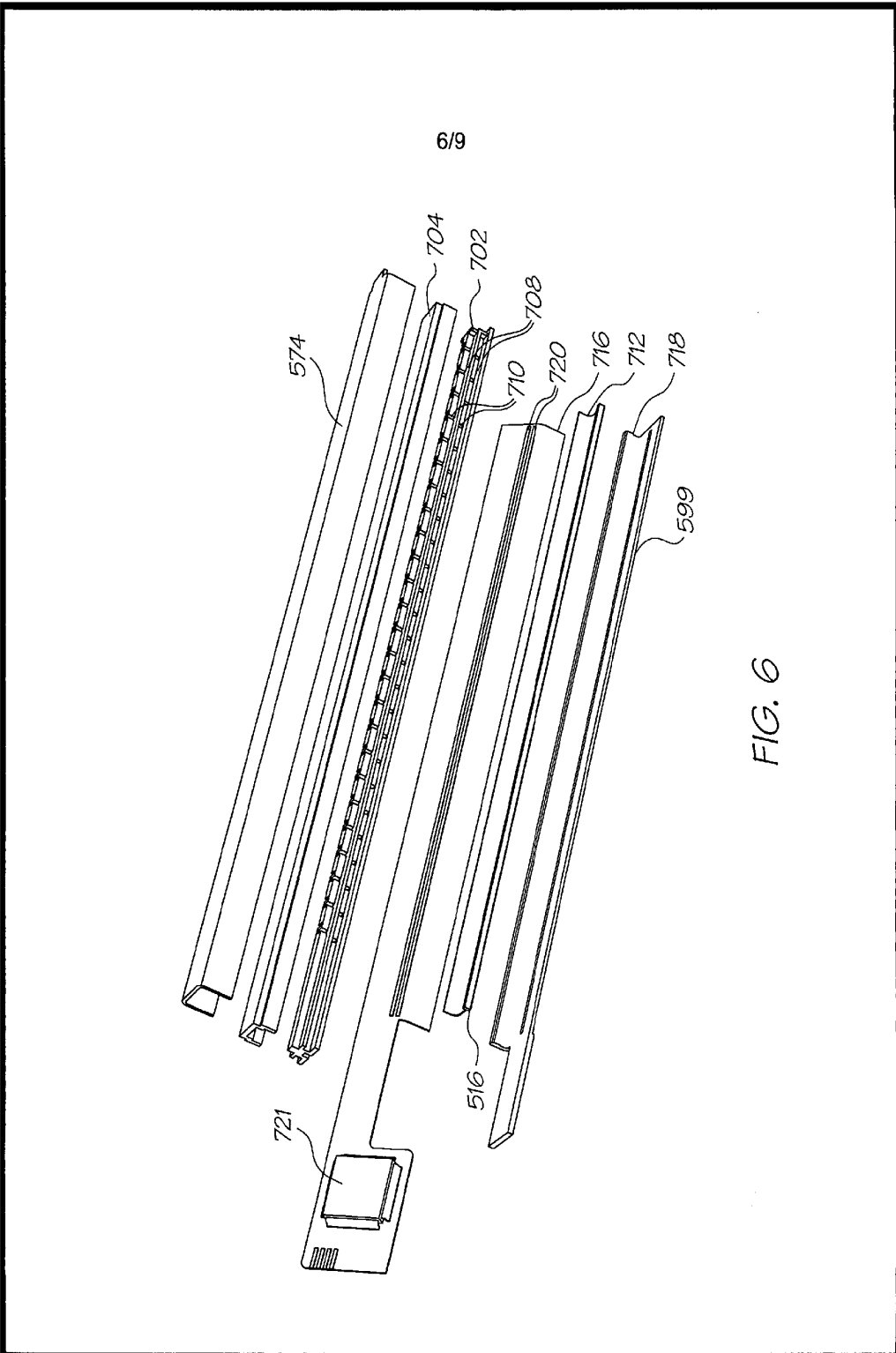

FIG. 6

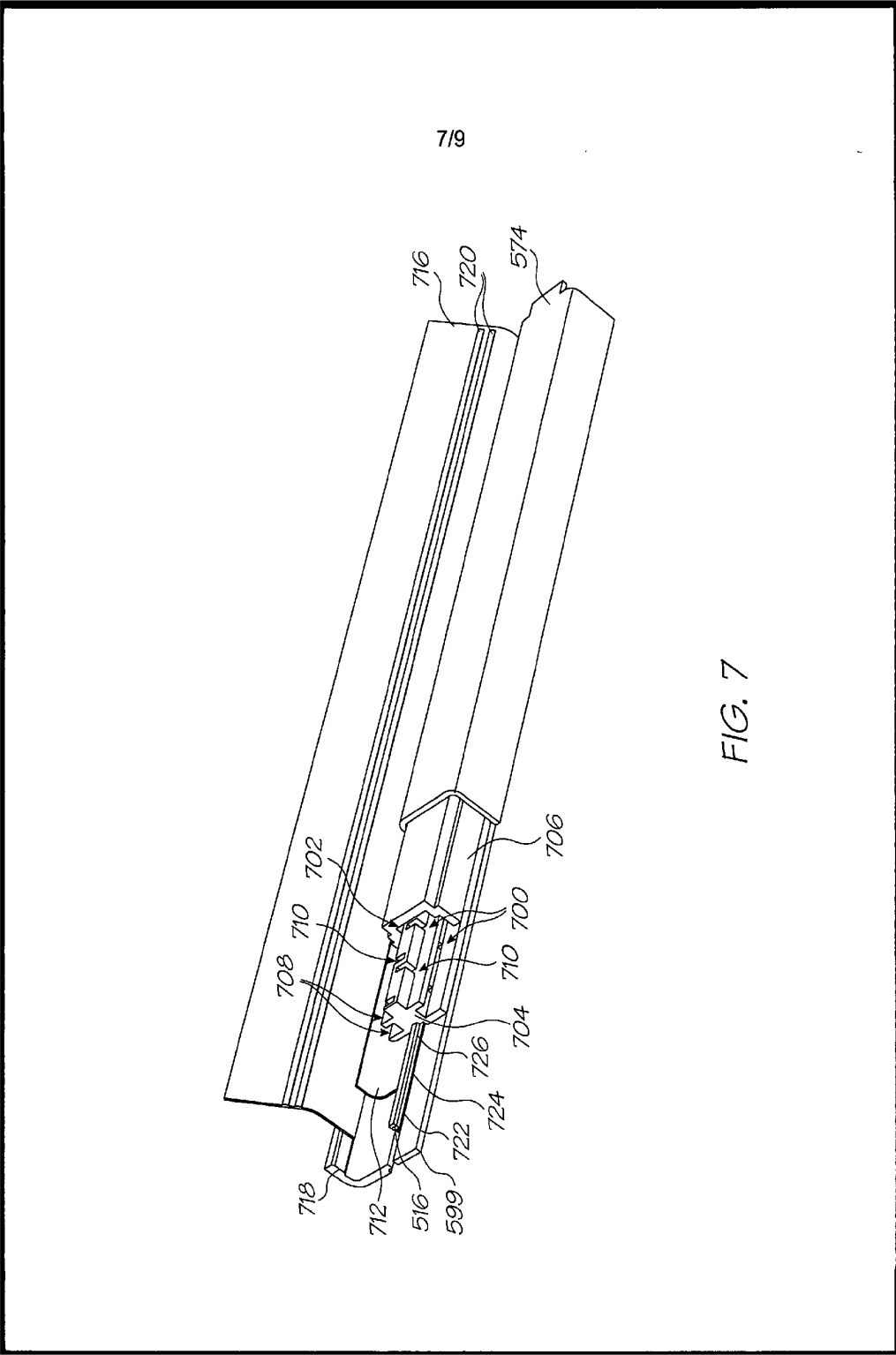

FIG. 7

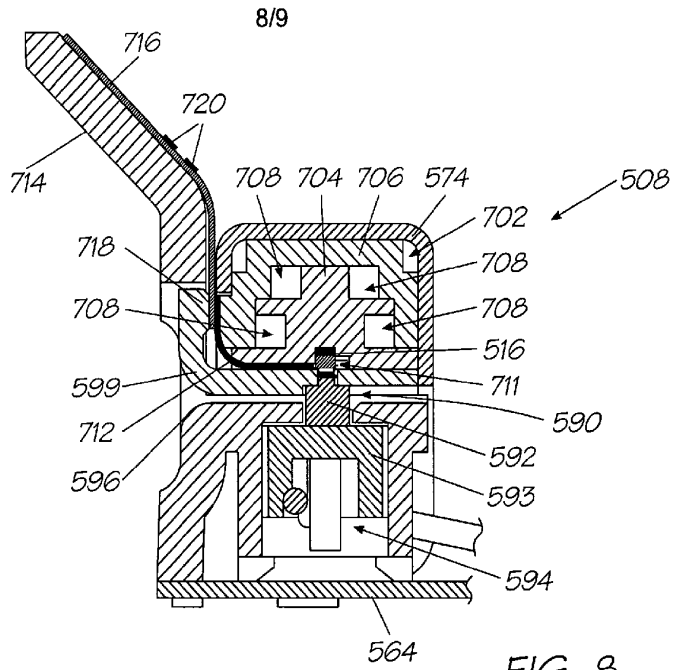

FIG. 8

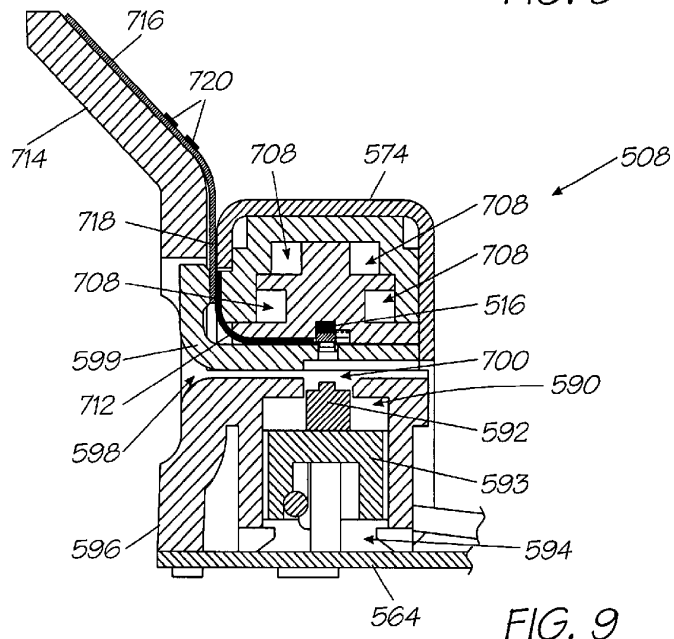

FIG. 9

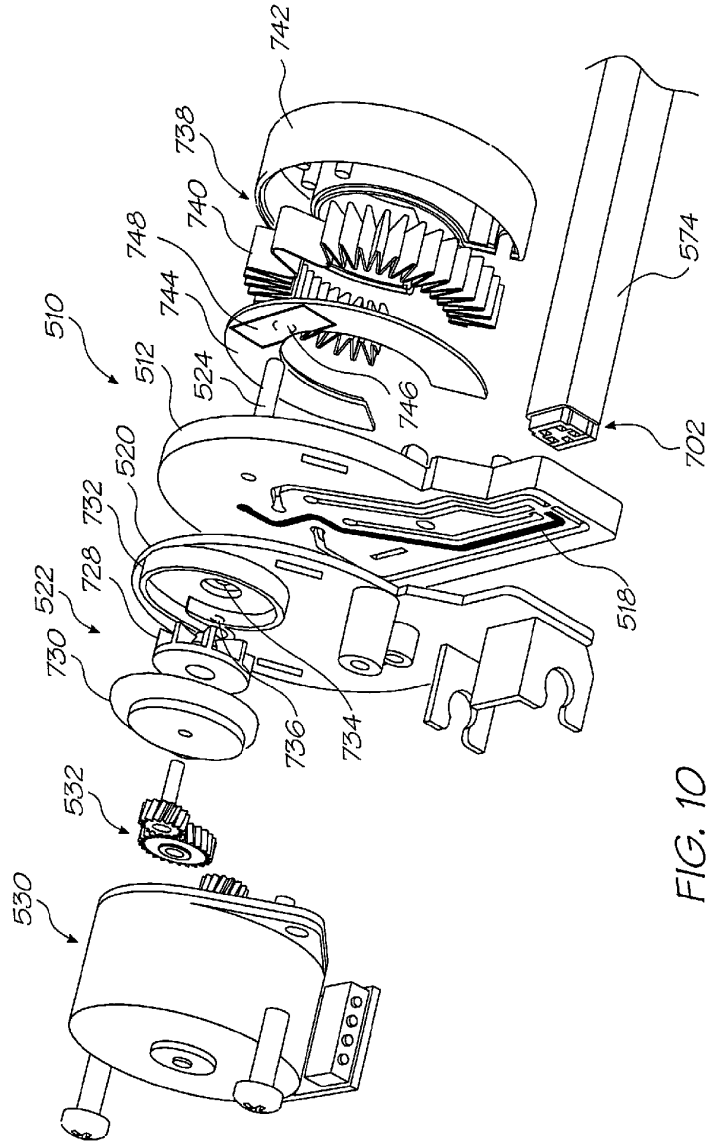

FIG. 10