

FORM 1

629039

SPRUSON & FERGUSON

COMMONWEALTH OF AUSTRALIA

PATENTS ACT 1952

APPLICATION FOR A STANDARD PATENT

Kimberly-Clark Corporation, of 401 North Lake Street, Neenah, Wisconsin, 54956, UNITED STATES OF AMERICA, hereby apply for the grant of a standard patent for an invention entitled:

Sprayed Adhesive System

which is described in the accompanying complete specification.

Details of basic application(s):-

<u>Basic Applic. No:</u>	<u>Country:</u>	<u>Application Date:</u>
408,019	US	15 September 1989

The address for service is:-

Spruson & Ferguson
Patent Attorneys
Level 33 St Martins Tower
31 Market Street
Sydney New South Wales Australia

DATED this ELEVENTH day of SEPTEMBER 1990

Kimberly-Clark Corporation

By: 

Registered Patent Attorney

TO: THE COMMISSIONER OF PATENTS
OUR REF: 139818
S&F CODE: 56610
5845/11

DECLARATION IN SUPPORT OF A
CONVENTION APPLICATION FOR A PATENT

In support of the Convention Application made for a
patent for an invention entitled:

Title of Invention

SPRAYED ADHESIVE SYSTEM

Full name(s) and
address(es) of
Declarant(s)

I/We Martin Herman Michael, Vice President and Chief Counsel
KIMBERLY-CLARK CORPORATION,
of having a place of business at
Neenah, Wisconsin, U.S.A.

do solemnly and sincerely declare as follows:-

Full name(s) of
Applicant(s)

~~1. I am/We are the applicant(s) for the patent~~

(or, in the case of an application by a body corporate)

1. I am/We are authorised by
KIMBERLY-CLARK CORPORATION

the applicant(s) for the patent to make this declaration on
its/~~their~~ behalf.

2. The basic application(s) as defined by Section 141 of the
Act was/~~were~~ made

in the United States of America

Basic Country(ies)

on September 15, 1989

Priority Date(s)

Basic Applicant(s)

by Richard Francis Keller, Terry Lee Springer and
Jeffrey James Jeanquart

~~3. I am/We are the actual inventor(s) of the invention referred
to in the basic application(s).~~

(or where a person other than the inventor is the applicant)

3. Richard Francis Keller Jeffrey James Jeanquart
Box 113 High Street 212 Edgewood Drive
of Fremont, Wisconsin 54940, U.S.A. Neenah, Wisconsin 54956, U.S.A.
Terry Lee Springer
834 Broad Street
Menasha, Wisconsin 54952, U.S.A. (respectively)

is/are the actual inventor(s) of the invention and the facts upon
which the applicant(s) is/~~are~~ entitled to make the application are
as follows: The said applicant is the assignee of the
actual inventor(s).

Set out how Applicant(s)
derive title from actual
inventor(s) e.g. The
Applicant(s) is/are the
assignee(s) of the
invention from the
inventor(s)

4. The basic application(s) referred to in paragraph 2 of this
Declaration was/~~were~~ the first application(s) made in a Convention
country in respect of the invention(s) the subject of the application.

Declared at Neenah, this 18th day of October 1990
Wisconsin, KIMBERLY-CLARK CORPORATION
U.S.A.

By: *Martin Herman Michael*
Signature of Declarant(s)
Martin Herman Michael

(12) PATENT ABRIDGMENT **(11) Document No. AU-B-62413/90**
(19) AUSTRALIAN PATENT OFFICE **(10) Acceptance No. 629039**

- (54) Title
SPRAYED ADHESIVE SYSTEM
- International Patent Classification(s)
(51)⁵ **B05D 005/10** **B05D 005/00**
- (21) Application No. : **62413/90** (22) Application Date : **11.09.90**
- (30) Priority Data
- (31) Number (32) Date (33) Country
408019 **15.09.89** **US UNITED STATES OF AMERICA**
- (43) Publication Date : **21.03.91**
- (44) Publication Date of Accepted Application : **24.09.92**
- (71) Applicant(s)
KIMBERLY-CLARK CORPORATION
- (72) Inventor(s)
JEFFREY JAMES JEANQUART; TERRY LEE SPRINGER; RICHARD FRANCIS KELLER
- (74) Attorney or Agent
SPRUSON & FERGUSON , GPO Box 3898, SYDNEY NSW 2001
- (56) Prior Art Documents
US 4785996
US 4031854
US 3911173
- (57) Claim

1. An apparatus for forming a substantially continuous filament of a thermoplastic work material and imparting a swirling motion thereto, comprising:

a body member which has a work material supply passage and a gas supply passage formed therein, said gas supply passage substantially aligned with and generally radially spaced from a longitudinal central axis of said body member, and said gas supply passage having substantially no inclination along a radial direction toward said central axis of said body member;

an outlet nozzle section which is connected to said body member and has a substantially conically tapered shape, said nozzle section having a nozzle extrusion passage formed therein in communication with said work material supply passage; and

a housing member which operably connects to said body member to delimit a substantially annular gas transfer zone in fluid communication with said gas supply passage and to delimit a substantially annular gas outlet passage around said nozzle section and in fluid communication with said gas transfer zone, said housing member including an exit section having inner wall surfaces which substantially parallel the substantially conically tapered shape of said nozzle section, and which are in a selected spaced relation from said nozzle section to define said gas outlet passage, said gas supply passage, said housing

(11) AU-B-62413/90
(10) 629039

-2-

exit section and said nozzle section configured to provide for a selected gas flow which imparts said filament swirling motion substantially without disintegrating said filament, said apparatus thereby constructed to deposit a substantially continuous, swirled filament of said work material onto a selected substrate.

35. A method for forming a substantially continuous filament of thermoplastic material and imparting a swirling motion thereto, comprising the steps of:

(a) supplying a thermoplastic work material to a nozzle section which has a substantially conically tapered shape;

(b) forming a substantially continuous filament of said work material which exits from said nozzle section;

(c) delivering a supply of gas through a gas delivery conduit into a substantially annular gas transfer zone which is positioned about a longitudinal central axis of said nozzle section;

(d) radially spacing said gas delivery conduit from said longitudinal central axis;

(e) substantially aligning said gas delivery conduit with said longitudinal central axis with substantially no inclination along a radial direction toward said longitudinal central axis;

(f) exiting said gas from said gas transfer zone through an annular, substantially conically tapered outlet passage which is located about said nozzle section and substantially parallels said conically tapered shape of said nozzle section; and

(g) moving said gas through said gas delivery conduit, gas transfer zone and outlet passage and past said nozzle section to provide for a selected gas flow which imparts said swirling motion to said filament while substantially avoiding a disintegration of said filament, said method thereby configured to deposit a substantially continuous, swirled filament of said material onto a selected substrate.

629039

S & F Ref: 139818

FORM 10

COMMONWEALTH OF AUSTRALIA

PATENTS ACT 1952

COMPLETE SPECIFICATION

(ORIGINAL)

FOR OFFICE USE:

Class Int Class

Complete Specification Lodged:
Accepted:
Published:

Priority:

Related Art:

Name and Address
of Applicant:

Kimberly-Clark Corporation
401 North Lake Street
Neenah Wisconsin 54956
UNITED STATES OF AMERICA

Address for Service:

Spruson & Ferguson, Patent Attorneys
Level 33 St Martins Tower, 31 Market Street
Sydney, New South Wales, 2000, Australia

Complete Specification for the invention entitled:

Sprayed Adhesive System

The following statement is a full description of this invention, including the best method of performing it known to me/us

S 017188 110590
08 110590

5845/12

ABSTRACT

A distinctive method and apparatus for forming a substantially continuous filament of a thermoplastic work material and for imparting a swirling motion thereto comprises a body member which has a work material supply passage and a gas supply passage formed therein. An outlet nozzle section connects to the body member and has a substantially conically tapered shape. The nozzle section has a nozzle extrusion passage formed therein in communication with the work material supply passage. A housing member operably connects to the body member to delimit a substantially annular gas transfer zone in fluid communication with the gas supply passage and to delimit a substantially annular gas outlet passage around the nozzle section. The housing member includes an exit section having inner wall surfaces which substantially parallel the conically tapered shape of the nozzle section. The inner wall surfaces are in a selected spaced relation from the nozzle section to define the gas outlet passage. The housing exit section and the nozzle section are configured to provide for a selected gas flow which imparts the filament swirling motion substantially without disintegrating the filament, the apparatus thereby constructed to deposit a substantially continuous, swirled filament of the work material onto a selected substrate.

SPRAYED ADHESIVE SYSTEMField of Invention

5 The present invention relates to a method and apparatus for
applying a selected pattern of work material onto a chosen substrate.
More particularly, the present invention relates to a method and
apparatus for spraying a selected pattern of hot-melt adhesive onto a
moving substrate layer to construct a garment article, such as a
10 disposable diaper.

Background of Invention

15 In the manufacture of disposable absorbent articles, such as
diapers, feminine care products, incontinence products, and the like,
adhesives have typically been applied in a pattern of multiple,
parallel glue lines which extend along the longitudinal dimension of
the article. Such glue line patterns leave unbonded gaps between the
lines, and the unbonded gap areas tend to have lower strength and
lower integrity. As a result, the article can be more susceptible to
20 stretching and tearing when adhesive tapes are employed to secure the
article on the wearer, and the article may be less able to hold
together and maintain its structure during use.

25 Sprayed and foamed adhesives have also been employed to assemble
together various component layers of disposable absorbent articles.
The adhesives may be thermoplastic-type adhesives or solvent-type
adhesives. For example, see U.S. Patent 3,523,536 to A. Ruffo and
U.S. Patent 4,118,531 to Minetola, et al. Swirled patterns of
adhesive have been employed to construct articles such as shoes. For
example, see U.S. Patent 3,911,173 issued October 7, 1975 to
30 J. Sprague.

35 Various air forming techniques have been employed to form
nonwoven fibrous webs. For example, U.S. Patent 4,478,624 issued
October 23, 1984 to J. Battigelli, et al. describes a technique which
employs a circular airflow component to help produce a more uniform
distribution of fibers laid onto a foraminous conveyor. U.S.
Patent 2,903,387 issued September 8, 1959 to W. Wade describes a
technique for producing reticulated fibrous webs containing tubular

or hollow fibers of elastomeric material. U.S. Patent 2,950,752 issued August 30, 1960 to P. Watson, et al. describes a spraying technique for forming relatively long, discontinuous, fine fibers of elastomeric materials. The fiber-forming liquid is extruded into and within a primary or high velocity stream of gas as a stream of plastic which is broken transversely into a plurality of fibers or fibrils before landing on a collector. U.S. Patent 2,988,469 issued June 13, 1961 to P. Watson describes a further spraying technique for forming relatively long, discontinuous, fine fibers of non-elastomeric material. A high velocity jet stream of gas attenuate and fibrillates a single large-diameter plastic stream into a multiplicity of fibers and fibrils without the formation of shot.

Molded articles and preforms have been produced by depositing fibers into a form and binding the fibers together with a resin binder. For example, U.S. Patent 3,796,617 issued March 12, 1974 to A. Wiltshire describes a method for making a fibrous preform which comprises the steps of randomly depositing short reinforcing fibers on a form, binding the fibers together with a settable resin binder, and rolling the resin-coated fibers on the form into a dimensionally uniform porous mat. U.S. Patent 3,833,698 describes a technique in which chopped fibers are directly deposited in a localized manner onto the interior surface of a screen form. The fibers are held in place by an airflow through the screen form into a vacuum chamber, and the deposited chopped fibers are sprayed with a heat-curable resin binder. U.S. Patent 3,904,339 issued September 9, 1975 to J. Dunn describes a technique for depositing glass fibers and curable resin into molds. A spray means for depositing the resin and fibers is supported on an arm which is pivoted about a selected axis.

Particular nozzle structures have been developed to form filaments from thermoplastic, melt-extrudable materials. The nozzles may be configured to produce a swirling air flow which disrupts the flow of extruded material into a plurality of fine fibers. For example, U.S. Patent 4,185,981 describes a technique for producing fibers from a viscous melt. High-speed gas streams have a component in the tangential direction of the circular sectional surface of the melt, and a component which approaches the central axial line of the melt towards the flowing direction of the melt and then departs from

the central axial line. The melt is continuously flown as fiber in the flowing direction and outwardly in the radial direction in a vortex form, which is spiral or helical or both. The fibrous melt which has flown away is accelerated and drawn into long fibers having a diameter of 10-100 microns, or short fibers having a diameter of 0.1-20 microns. The fibers can then be accumulated to form a fibrous mat.

U.S. Patent 2,571,457 issued October 16, 1951 to R. Ladisch describes a technique in which a cyclone of gas disrupts a "filament forming liquid" into fibers and/or filaments which may be collected on a moving belt. U.S. Patent 3,017,664 issued January 23, 1962 to R. Ladisch describes a fiber-forming nozzle wherein a fiber-forming liquid is spread over the outside wall of a circular body as a thin film, and wherein a stream of spiraling elastic fluid rotates at high velocity to draw out fibers which are picked up from the film of fiber-forming liquid.

U.S. Patent 3,905,734 issued September 16, 1975 to E. Blair describes an apparatus for continuously making a tube of meltblown microfibers. The meltblown microfibers are deposited longitudinally upon a circumferential surface of a mandrel and then are axially withdrawn from one end of the mandrel tube.

U.S. Patent 3,543,332 issued December 1, 1970 to W. Wagner, et al. describes a spinning nozzle for spray spinning molten fiber-forming materials and forming fibrous assemblies such as nonwoven fabrics and the like. The nozzle includes gas passages which are inclined so that their axes do not intersect the axis of an extrusion orifice in the nozzle. Gas streams act to swirl filaments formed from the fiber-forming material to produce a random expanding conical pattern as the filaments travel toward a moving collector.

An article entitled "Application Potential of Controlled Fiberization Spray Technology", Nonwovens Industry, January 1988, by J. Raterman describes a process for spraying pressure-sensitive hot-melts. The process employs a line of spray heads using nozzles with integral air jets that produce fine monofilaments of adhesive swirled at high speeds in a helix or spiral pattern.

Conventional spray techniques, such as those discussed above, have been excessively complex, and have not adequately regulated the

distribution pattern and placements of the sprayed material onto a substrate. Ordinarily, the sprayed materials are deposited in a generally random pattern, and there can be excessive overspray and misplacement of the deposited materials. Where the sprayed materials are
5 composed of adhesives, such as hot-melt adhesives, the overspray and misplacement can contaminate the equipment and require excessive maintenance. For the purpose of applying adhesives onto a substrate, the conventional techniques have not provided a sufficiently accurate control over the deposition pattern and have not been sufficiently flexible or
10 readily adjustable to accommodate the placement of adhesives onto different widths of substrate. In addition, the conventional spray devices have been excessively sensitive to plugging when employed with viscous liquids, such as hot-melt adhesives.

Brief Description of the Invention

15 The present invention provides an apparatus for forming a substantially continuous filament of a thermoplastic work material and imparting a swirling motion thereto, comprising:

a body member which has a work material supply passage and a gas supply passage formed therein, said gas supply passage substantially
20 aligned with and generally radially spaced from a longitudinal central axis of said body member, and said gas supply passage having substantially no inclination along a radial direction toward said central axis of said body member;

an outlet nozzle section which is connected to said body member and
25 has a substantially conically tapered shape, said nozzle section having a nozzle extrusion passage formed therein in communication with said work material supply passage; and

a housing member which operably connects to said body member to delimit a substantially annular gas transfer zone in fluid communication
30 with said gas supply passage and to delimit a substantially annular gas outlet passage around said nozzle section and in fluid communication with said gas transfer zone, said housing member including an exit section having inner wall surfaces which substantially parallel the substantially conically tapered shape of said nozzle section, and which are in a
35 selected spaced relation from said nozzle section to define said gas outlet passage, said gas supply passage, said housing exit section and said nozzle section configured to provide for a selected gas flow which

amg/0735y



imparts said filament swirling motion substantially without disintegrating said filament, said apparatus thereby constructed to deposit a substantially continuous, swirled filament of said work material onto a selected substrate.

5 The invention further provides a method for forming a substantially continuous filament of thermoplastic material and imparting a swirling motion thereto, comprising the steps of:

(a) supplying a thermoplastic work material to a nozzle section which has a substantially conically tapered shape;

10 (b) forming a substantially continuous filament of said work material which exits from said nozzle section;

(c) delivering a supply of gas through a gas delivery conduit into a substantially annular gas transfer zone which is positioned about a longitudinal central axis of said nozzle section;

15 (d) radially spacing said gas delivery conduit from said longitudinal central axis;

(e) substantially aligning said gas delivery conduit with said longitudinal central axis with substantially no inclination along a radial direction toward said longitudinal central axis;

20 (f) exiting said gas from said gas transfer zone through an annular, substantially conically tapered outlet passage which is located about said nozzle section and substantially parallels said conically tapered shape of said nozzle section; and

(g) moving said gas through said gas delivery conduit, gas
25 transfer zone and outlet passage and past said nozzle section to provide for a selected gas flow which imparts said swirling motion to said filament while substantially avoiding a disintegration of said filament, said method thereby configured to deposit a substantially continuous, swirled filament of said material onto a selected substrate.

30 In a further form the invention provides a method a method for forming a substantially continuous filament of a thermoplastic work material and imparting a swirling motion thereto, comprising the steps of:

providing a body member which has a work material supply passage and a gas supply passage formed therein;

35 connecting to said body member an outlet nozzle section which has a substantially conically tapered shape and has a nozzle extrusion passage formed therein in communication with said work material supply passage;

amg/0735y



and

operably connecting to said body member a housing member which delimits a substantially annular gas transfer zone in fluid communication with a gas outlet passage around said nozzle section, said gas supply
5 passage arranged in fluid communication with said gas transfer zone and arranged substantially aligned with and generally radially spaced from a longitudinal central axis of said body member, and said gas supply passage having substantially no inclination along a radial direction toward said central axis of said body member, said housing member
10 including an exit section having inner wall surfaces which substantially parallel the substantially conically tapered shape of said nozzle section and which are in a selected spaced relation from said nozzle section to define said gas outlet passage, said gas supply passage housing exit section and said nozzle section configured to provide for a selected gas
15 flow which imparts said filament swirling motion substantially without disintegrating said filament, said method thereby configured to deposit a substantially continuous, swirled filament of said material onto a selected substrate.

The invention can additionally provide a distinctive absorbent
20 article comprising an outer layer, a liquid-permeable inner layer, an absorbent body positioned between the inner and outer layers. A pattern of adhesive is arranged to secure one or more of the layers to the absorbent body, and is composed of a plurality of accurately positioned, juxtaposed, substantially continuous, semi-cycloidal arrays of adhesive
25 extending substantially along a longitudinal dimensions of the article.

The method and apparatus of the present invention can advantageously provide a more accurate placement of deposited work material onto a substrate layer, and can provide a more precise formation of a desired deposition pattern. Since the work material, such as a
30 molten adhesive, is gas-entrained for a discrete distance before contacting the substrate web, the adhesive has an opportunity to cool, or depending on the temperature of the gas, may be held or maintained at a selected temperature. A cooling of the adhesive reduces the probability that the web will be exposed to excessive amounts of heat from the
35 adhesive. The technique of the present

amg/0735y



invention can be readily adjusted to accommodate and control the placement of material onto substrates of various widths. When compared to conventional devices, the method and apparatus of the invention can better prevent the undesired upwards spiraling of the extruded filament onto the nozzle unit, and can help prevent any resultant plugging of the air passages. Thus, the technique of the invention can help reduce the amount of overspray waste and help reduce the maintenance requirements for the associated production equipment. The invention can further provide a more effective distribution of adhesive on the applied surface area of the article, and can thereby provide an article having more uniform strength characteristics. An article constructed in accordance with the invention may be perceived by the consumer as having increased integrity.

Brief Description of the Drawings

The invention will be more fully understood and further advantages will become apparent when reference is made to the following detailed description of the invention and the drawings, in which:

Fig. 1 representatively shows a side elevational view of the apparatus of the present invention;

Fig. 1A representatively shows an enlarged view of the region circled in Fig. 1;

Fig. 2 representatively shows a plan view of an assembly comprising two nozzle banks;

Fig. 3 representatively shows a side elevational view of the assembly illustrated in Fig. 2;

Fig. 4 representatively shows a cross-sectional view of an individual nozzle mechanism;

Fig. 5 representatively shows a cross-sectional view of a plug assembly employed to adjust the deposition width and pattern provided by the present invention;

Fig. 6 representatively shows an enlarged cross-sectional view of an individual nozzle mechanism;

Fig. 7 representatively shows a cross-sectional view of an alternative configuration of a nozzle mechanism;

Fig. 8 representatively shows a side elevational view of a nozzle having an inclined gas supply passage;

Fig. 9 representatively shows an end view of the nozzle illustrated in Fig. 8 taken along direction 9-9;

5 Fig. 10 representatively shows a deposition array comprising a semi-cycloidal pattern;

Fig. 11 representatively shows a deposition array comprising a plurality of juxtaposed, semi-cycloidal patterns;

10 Fig. 12 shows a schematic representation of the adhesive delivery system; and

Fig. 13 shows a schematic representation of the heated air delivery system;

Fig. 14 representatively shows a disposable diaper constructed in accordance with the present invention; and

15 Fig. 15 representatively shows a graphic comparison of end seal strengths provided by conventional bead-lines of adhesive and by the swirled adhesive patterns of the present invention.

Detailed Description of the Invention

20 The present invention provides a distinctive method and apparatus for depositing a selected pattern of work material onto a selected substrate, such as the outer cover layer of a disposable diaper. While the following description will be made in the context of depositing a hot-melt adhesive, it will be readily apparent to persons of ordinary skill that other types of adhesives and other types of viscous, extrudable materials may also be applied by employing the technique of the invention. Similarly, while the following description will be made in the context of constructing a disposable diaper, it will be readily apparent that the technique of the present invention would also be suitable for producing other articles, such as feminine care products, incontinence products, disposable gowns, laminated webs, and the like.

25
30
35 The described embodiments of the present invention are distinctively constructed and arranged to form a substantially continuous filament of a thermoplastic work material and to impart a swirling motion thereto. As a result, a substantially continuous,

swirled filament of the work material can be deposited onto a selected substrate.

Figs. 1 and 1A representatively show an apparatus for depositing a closely controlled pattern of work material, such as hot-melt adhesive 12, onto a selected substrate, such as web 14. The apparatus includes a supply means, such as nozzle assembly 10, for forming at least one, substantially continuous stream of the material. Gas directing means form at least one gas stream, which has a selected velocity and is arranged to entrain the material stream 11 to impart and substantially maintain a relatively precise swirling motion to the material stream as it moves toward substrate web 14. Transport means, such as conveyor rollers 15 and 16, move the substrate relative to the supplying means along a selected machine direction 27. Regulating means, including pumps 33 (Fig. 12) and pressure control valve 18 (Fig. 13), control the material stream and the velocity of the gas stream, respectively, to direct material stream 11 in a selected path toward substrate 14 and deposit the material thereon to form a substantially continuous, semi-cycloidal pattern of the material on substrate 14.

Roller 15 may optionally be a constant temperature roll which is held at a temperature below or above the ambient temperature, as desired. As a result, roller 15 can operably support and guide web 14, and can also operably cool or heat the web. For example, roller 15 may be a chill roll which is conventionally configured with a plurality of internal passages, and constructed and arranged to conduct and transport a suitable liquid coolant therethrough. The coolant can be cooled by a conventional refrigeration unit to a temperature of about 18°C, and the circulation of the coolant through the chill roll operably maintains the outer surface of the chill roll at a predetermined temperature. The resultant cooling action provided by chill roll 15 helps prevent excessive heating of web 14 by the hot-melt adhesive deposited thereon, and can accelerate the solidification of the adhesive on the web.

A drip plate 25 is located below the position occupied by web 14 as the web moves over the conveyor rollers and past the location of nozzle assembly 10. The drip plate is constructed and arranged to intercept and catch any excess hot-melt adhesive which might be

expelled or drip from the nozzle units 24 during any time that web 14 is absent from the system. The presence of drip plate 25 can thereby advantageously reduce the contamination of the equipment by fugitive adhesive, and reduce the amount of system maintenance. In particular, the presence of drip plate 25 can help prevent excessive equipment contamination during web splicing operations. In the shown embodiment, the drip plate is removable for cleaning.

With reference to Figs. 2 and 3, nozzle assembly 10 includes a first nozzle bank 20 and at least a second nozzle bank 22, with the first nozzle bank spaced a selected offset distance 23 from the second nozzle bank along machine direction 27 of the apparatus. The offset distance is arranged and configured to substantially prevent interference between the deposition patterns formed by each of the individual nozzle units 24. Each nozzle bank 20, 22 includes a plurality of spaced-apart nozzle units 24 which are substantially aligned along a cross-direction 26 of the apparatus. The nozzles of second nozzle bank 22 are, however, positioned in an interposed, staggered arrangement relative to the nozzles of first nozzle bank 20. Each nozzle includes an orifice 82 for forming a substantially continuous stream of hot-melt adhesive 11, and includes a gas delivery system for forming a selected gas stream which has a selected velocity and is arranged to entrain the associated, individual stream of hot-melt adhesive 11 issuing from orifice 82. The gas stream is distinctively directed to impart a swirling motion to each material stream 11 as it moves toward web 14. In the illustrated embodiment, the individual nozzle units 24 within a particular nozzle bank are substantially equally spaced along the cross-direction. Alternatively, the individual nozzle units within a nozzle bank may be unequally spaced, if desired.

Fig. 3 representatively shows a side view of nozzle assembly 10 comprising nozzle plate 32 and transfer plate 44 which are joined and held together with suitable fastening means, such as bolts 46. The nozzle plate and transfer plate are formed of a suitable material, such as metal. In the illustrated embodiment, the nozzle and transfer plates are composed of heat treated stainless steel. A suitable gas, such as air, is introduced into nozzle plate 32 through one or more gas inlets 36. In the illustrated embodiment, there are

two individual gas inlets, but more or fewer inlets could also be employed. A desired liquid, such as a molten hot-melt adhesive, which is to be applied to web 14, is provided into transfer plate 44 through liquid inlets 84 and 84a. In the illustrated embodiment, liquid inlets 84 supply molten adhesive to nozzles in first nozzle bank 20, and liquid inlets 84a supply molten adhesive to nozzles in second nozzle bank 22. Each individual nozzle unit receives adhesive supplied through an individual inlet. Excess liquid, which is not expelled through nozzle units 24, is recirculated out from nozzle plate 32, as discussed in more detail below with respect to Fig. 12. The recirculation of excess hot-melt adhesive can advantageously provide improved control over the deposition patterns of adhesive onto web 14 and can facilitate changes in the system to increase or decrease the total cross-directional width of web 14 which is covered by the array of adhesive deposition patterns.

A more detailed illustration of the environment around an individual nozzle unit 24 is representatively shown in Fig. 4. In the illustrated embodiment, nozzle plate 32 is configured with a plurality of nozzle bore holes 48 which extend through the thickness dimension of the nozzle plate and are suitably positioned in spaced arrangement corresponding to the desired locations of the individual nozzle units. Each bore hole 48 has an expanded region 70 of increased diameter located adjacent to one major surface 54 of nozzle plate 32. As a result, the nozzle bore has a stepped cross-sectional configuration.

Each bore hole 48 is constructed to receive therein a nozzle body 50 which is secured with suitable fastening means, such as bolts 52 (Fig. 2). The nozzle body is constructed of a suitable material, such as metal or high-strength, temperature-resistant plastic. In the illustrated embodiment, the nozzle body is composed of hardened stainless steel.

Nozzle body member 50 includes a stem portion 56 and a head portion 58, and has work material (e.g. adhesive) supply passage 64 formed axially therethrough. Stem portion 56 includes two circumferential grooves 60 configured to accommodate the placement of O-ring type seals 61 composed of a conventional, high temperature elastomeric material, such as Viton type O-rings, which are produced

by Parker Hannifin, a company having facilities in Lexington, Kentucky. Grooves 60 extend circumferentially around stem portion 56, and are constructed and arranged to hold the O-rings in sealing engagement with the interior wall surface of bore 48. In addition, grooves 60 are axially spaced along the length of stem portion 56, and are arranged to bracket either side of adhesive return port 62, which is formed through nozzle plate 32 in fluid communication with bore 48. In the illustrated embodiment, stem portion 56 is necked down with a reduced diameter at its medial section 66. The medial section cooperates with expanded region 70 of bore 48 to provide an annular passageway between the nozzle stem and the side wall of the bore hole. A gas inlet port 68 is formed through nozzle plate 32 and positioned in fluid communication with expanded region 70 of bore 48. Gasket member 38 provides a substantially airtight seal between surface 54 and flange 72. The gasket is composed of a conventional fibrous gasket material, and is configured to reduce air leaks caused by irregularities in the mating surfaces arising from manufacturing machining tolerances.

Head portion 58 of nozzle body 50 includes an annular flange 72 which extends about the head portion and is constructed to seat in engagement with the outer surface 54 of nozzle plate 32. The head portion further includes a gas passage 74, which is formed through the head portion. In the shown embodiment, gas passage 74 extends axially through the head portion of nozzle body 50 and is radially spaced from adhesive supply passage 64. The gas passage is constructed and arranged to be in fluid communication with expanded region 70 of bore 48.

A more detailed illustration of an individual nozzle unit 24 is representatively shown in Fig. 6. The nozzle unit includes a body member 50 which has a work material supply passage 64 and a gas supply passage 74 formed therein. An outlet nozzle section 80 is connected to body member 50 and has a substantially conically tapered shape. The nozzle section has a nozzle extrusion passage 65 therein with the extrusion passage arranged in operable communication with work material passage 64. A housing member 78 operably connects to body member 50 to delimit a substantially annular gas transfer zone, such as annular groove 76, which is in fluid communication with gas

passage 74, and delimits a substantially annular gas outlet passage 63 around nozzle section 80. Housing member 78 includes an exit section 67 having inner wall surfaces 69 which substantially parallel the substantially conically tapered shape of nozzle section 80. The inner wall surfaces are in a selected, spaced relation from nozzle section 80 to define gas outlet passage 63. The housing exit section and the nozzle section are configured to provide for a selected gas flow which imparts the desired swirling motion to filament 11 substantially without disintegrating the filament. In particular, the nozzle unit is substantially free of air currents or other mechanisms which are arranged to deliberately break the filament into discrete fibers or otherwise significantly disrupt the continuity of the swirling filament of work material. Accordingly, the nozzle unit can advantageously deposit a substantially continuous, swirled filament of work material onto a selected substrate.

In the illustrated embodiment, the distal, terminal end of head portion 58 includes an annular groove 76, which is formed into an axial end face 86 of the head portion. Groove 76 is configured to connect in fluid communication with gas passage 74, and to help provide a circumferential, substantially annular gas transfer zone around outlet nozzle section 80. The illustrated gas transfer zone has an axial depth within the range of about 0.050 - 0.052 inches (0.127 - 0.128 cm).

The opening of gas passage 74 into the gas transfer zone provided by groove 76 is spaced radially outward from gas outlet passage 63 by a selected distance 142. In a particular aspect of the invention, spacing distance 142 corresponds to approximately 0.5 - 0.9 times the effective diameter of the opening of gas passage 74 into the gas transfer zone. In the illustrated embodiment, spacing distance 142 is within the range of about 0.040 - 0.044 inches (about 0.102 - 0.112 cm), which corresponds to approximately 0.7 - 0.8 times the diameter of gas passage 74.

Gas passage 74 is substantially aligned with the longitudinal axis of nozzle body 50, and in the shown embodiment, comprises a generally cylindrical bore through the nozzle body. The bore has a diameter 144 and a length 146. In a particular aspect of the

invention, the length-to-diameter ratio of the gas passage is at least about 9:1 and is preferably within the range of about 9:1 to 12:1 to provide improved effectiveness. If the length-to-diameter ratio of gas passage 74 is too small, the nozzle unit may not impart the desired swirling motion to the filament of work material.

To provide additional advantages, gas supply passage 74 may optionally be inclined at a selected inclination angle 148 with respect to the longitudinal axis of nozzle body 50. In an aspect of the invention representatively shown in Figs. 8 and 9, the gas supply passage is inclined from the axial direction and tilted along a circumferential direction of the body member at an inclination angle 148 of not more than about 25°. Preferably, the gas supply passage is constructed to have substantially no inclination along the radial direction toward the central axis 160 of nozzle body 50. An inclination of gas passage 74 toward the central longitudinal axis of the nozzle body may impede the formation of the desired swirling motion of filament 11.

Outlet nozzle section 80 is operably connected to the end of head portion 58, and in the shown embodiment is integrally formed with the head portion. Nozzle section 80 has an axially extending extrusion passage 65 formed substantially along the nozzle centerline for conducting molten work material therethrough. Extrusion passage 65 is configured to connect in fluid communication with supply passage 64, and generally comprises a cylindrical bore having a diameter 132 and a length 134. To provide a desired filament of work material, such as hot-melt adhesive, extrusion passage 65 has a length-to-diameter ratio of at least about 8:1, and preferably has a length-to-diameter ratio of at least about 10:1 to provide improved effectiveness. Other preferred embodiments can be constructed with a length-to-diameter ratio within the range of about 8:1 - 12:1. In the illustrated embodiment, extrusion passage 65 is configured with a diameter of about 0.0305-0.0762 cm. (about 0.012-0.030 in.). Preferably, the diameter of extrusion passage 65 is about 0.0457 - 0.0635 cm. (about 0.018-0.025 in.), and more preferably the diameter is about 0.0508 cm. to provide improved performance.

As representatively shown in Fig. 6, nozzle section 80 has a tapered, substantially conical shape with the apex of the cone

directed toward orifice 82, which is located at the exit from extrusion passage 65. In the illustrated embodiment, nozzle section 80 has an approximately frusta-conical shape to accommodate the formation of extrusion passage 65 and to facilitate the formation of a regular, uniformly shaped outlet opening 82 at the end of the extrusion passage. The cone angle 136 of the nozzle section is at least about 30°, and preferably is at least about 40°. Also, the cone angle is not more than about 60° and preferably is not more than about 50° to provide improved effectiveness. In the shown embodiment, the cone angle is approximately 45°.

The outward, conical surface of nozzle section 80 is substantially smooth, and is substantially free of any grooves, flutes, guide channels, vanes or the like which would operate to mechanically contact and guide the airstream in gas outlet passage 63 into a swirling motion. It has been found that the distinctive configuration of the present invention can produce a desired swirling gas stream without the use of the deflecting or steering mechanisms typically employed to direct the gas flow.

Housing member 78 to nozzle body 50, and in the shown embodiment, is threaded onto the nozzle body. The housing member cooperates with groove 76 to define the gas transfer zone, and cooperates with nozzle section 80 to define gas outlet passage 63. In particular, an inner wall surface 69 is configured for positioning in a substantially parallel arrangement with respect to the conically tapered shape of nozzle section 80. In the illustrated embodiment, the inward, conical face of wall surface 69 is substantially smooth, and is substantially free of any grooves, flutes, guide channels, vanes or the like which would operate to mechanically contact and guide the airstream in gas outlet passage 63 into a swirling motion. Wall surface 69 has a selected spacing 138 from nozzle section 80. Spacing distance 138 is within the range of about 0.016 - 0.018 inches (about 0.041 - 0.046 cm) and is substantially uniform over the conical surface of nozzle section 80.

In the shown embodiment, the outward conical surface of nozzle section 80 and inner wall surface 69 both have the configuration of a right circular cone, and the axial centerline of nozzle section 80 is substantially aligned with the conical centerline of wall surface 69

to provide a generally uniform, annular, conical gas outlet passage 63. The effective length 140 of gas passage 63 is at least about 0.093 inches (about 0.236 cm), and in the shown embodiment is approximately 0.115 inches (about 0.292 cm). In another aspect of the invention, nozzle section 80 may be asymmetrically positioned with respect to wall surface 69 to produce a non-uniformly shaped, unsymmetrical gas outlet passage 63. Such a configuration can be employed to produce a gas stream which entrains filament 11 into a swirling motion but veers the swirling filament in a direction which is offset or angled with respect to the longitudinal axis 160 of nozzle body 50. The configuration where gas outlet passage 63 is asymmetrically disposed around the nozzle section can, for example, be employed to selectively configured the composite pattern of hot melt adhesive deposited onto a substrate.

Gas outlet passage 63 is in fluid communication with annular groove 76, and is configured to direct a distinctive stream of gas from groove 76, through passage 63 and into the ambient atmosphere surrounding the outlet from extrusion passage 65. More particularly, the present invention is constructed and arranged to produce a gas stream having both an axial velocity component as well as a circumferential velocity component.

For the purposes of the present description, the axial direction is along the axis of nozzle body 50, and typically is along the direction defined by extrusion passage 65. The circumferential direction is perpendicular to the axial direction and substantially tangential to a circle which is substantially centered on orifice 82.

The resultant gas stream around extrusion passage 65 can operate to entrain the stream of hot-melt adhesive issuing forth from extrusion passage 65, and to impart a generally circular, swirling motion to the molten adhesive stream after the adhesive has exited from the passage. The adhesive stream advantageously remains in the form of a substantially continuous filament traveling along a generally helical path. The helical path has an expanding diameter, and the expansion can be selectively controlled by adjusting the configuration of nozzle unit 24.

In a particular aspect of the invention, the swirling gas stream and the supplied air pressure are configured and arranged to entrain the stream of hot-melt adhesive and impart at least about 300 swirls per second. Preferably, the invention imparts about 400-600 swirls per second to the adhesive stream, and more preferably, the invention imparts about 500 swirls per second to provide improved control of the adhesive deposition pattern.

The present invention can advantageously provide desired adhesive patterns while employing relatively low air pressures and relatively low gas stream velocities. In particular, the invention can operate effectively while employing air pressures within the range of about 15 - 30 psi (about 103 - 207 kPa). In addition, the invention can operate effectively while employing gas velocities of not more than about 6000 feet/minute ^(1800 m/min). In one aspect of the invention, the method and apparatus are configured to operate with the gas steam exiting from gas passage 63 at a velocity of about 3,000 feet/minute (900 m/min).

In the illustrated embodiment housing member 78 engages threads formed on the outer surface of head portion 58. It is readily apparent, however, that other fastening systems may also be employed to attach or otherwise interconnect the housing member and the nozzle head portion. As representatively shown in Figure 6, housing member 78 includes an annular ridge member 79 which extends outwardly and longitudinally from an end face of the housing member, and extends along a circumferential edge section of the housing member. Ridge member 79 also extends radially inward toward extrusion passage 65 and terminates at a position which is spaced from the extrusion passage by a selected radial distance 77. In the shown embodiment, this radial spacing distance is within the range of about 0.521 - 0.625 cm, and preferably is about 0.607 cm. Ridge member 79 also extends longitudinally along the axial dimension of nozzle body 50 by a selected distance 75, which in the shown embodiment is within the range of about 0.07 - 0.11 cm, and preferably is about 0.09 cm. As a result, ridge member 79 delimits a substantially cylindrical recess or chamber 81 into which gas passage 63 and extrusion passage 65 exit. The chamber has a radius 77 and a length 75. The inward facing wall surface 30 of the ridge member may optionally be



configured with a bevel angle 150 to increase or decrease the diameter of the adhesive swirl pattern formed on the substrate. For example, increasing the bevel angle can increase the rate of expansion of the swirling adhesive filament to form a larger diameter swirl pattern. In a particular aspect of the invention, the bevel angle is within the range of about 0 - 60° and in the shown embodiment the bevel angle is about 45°. In the shown embodiment, the exit region of nozzle 80 at orifice 82 is positioned substantially flush with the immediately adjacent edge of chamber 81 defined by housing 78. In an optional arrangement, nozzle section 80 may be configured such that the exit of nozzle 80 protrudes into chamber 81 by a distance which is within the range of about 0.005 - 0.007 inches (about 0.013 - 0.015 cm).

To maintain the desired, substantially continuous configuration of filament 11, nozzle unit 24 is configured to be substantially free of gas streams or other mechanisms which might disrupt the continuity of the swirling filament of work material. As a result, the present invention can advantageously impart a swirling motion to filament 11 while substantially avoiding a breaking or disintegration of the filament. As a result, a substantially continuous swirled filament of work material can be deposited onto the selected substrate.

It has been found that various factors can affect the diameter of the deposition pattern. Such factors include, for example, the air-to-adhesive ratio, the adhesive viscosity and the distance between nozzle section 80 and web 14. Accordingly, it is contemplated that some adjustments to the system will need to be made depending upon the physical properties of the adhesive or other work material being deposited onto web 14.

It has also been found that the size and diameter of the deposition pattern can be effectively regulated by controlling the dimensions of chamber 81. In particular, the rate of radial expansion of the path of the swirling adhesive stream can be adjusted by selectively increasing or decreasing the axial length dimension 75 of chamber 81. For a given distance between nozzle unit 24 and web 14, increasing the axial length dimension can reduce the rate of expansion and produce a deposition pattern having a relatively narrower width 91 (Fig. 11). Decreasing the axial dimension can

increase the rate of expansion and produce a deposition pattern having a relatively greater width. With the shown embodiment of the invention, for example, the axial length 75 of flange member 79, and thus the axial length of chamber 81, is adjusted to be within the
5 range of about 0.076 - 0.10 cm. to expand the path of the adhesive stream at a rate sufficient to allow placement of web 14 at a distance of about 2.5 - 3.5 cm. from the exit of extrusion passage 65 in nozzle unit 24, while still providing a deposited adhesive pattern width 91 of at least about 1.2 cm.

10 The distinctive configuration of the present invention can advantageously improve the system tolerance to start-up conditions. During start-up, there is relatively more air and relatively less adhesive than during normal running conditions. With conventional systems, excessive amounts of adhesive may be drawn up onto the
15 nozzle unit, thereby fouling the nozzle and interfering with the formation of desired adhesive deposition patterns. Such difficulties can be reduced by employing the present invention.

With reference to Fig. 7, nozzle unit 24 may advantageously be configured to reduce the dripping or drooling of molten work material during those periods of time when the operation of the nozzle unit is shut down. With this particular aspect of the invention, a forcing means such as spring 124 is disposed within nozzle body 50 the forcing means resiliently urges a valving member 126 against a valve seating member 128 to selectively block the flow of work material through nozzle body 50. In the illustrated embodiment, work material supply passage 64 is enlarged to form a valving chamber 130 which is suitably sized to accommodate spring 124. One end of the spring engages a bottom wall section of chamber 130 and the opposite end of the spring engages valve member 126. Valve seat member 128 is assembled into the open end of chamber 130, and in the shown embodiment is secured to nozzle body 50 with a threaded engagement. It is readily apparent that other fastening systems may also be employed. Valve seat member 128 includes a bore channel 129 extending axially therethrough for conducting work material into
25 valve chamber 130, through which the work material passes into supply passage 64. When valve seat member 128 is assembled into nozzle body 50, the valve seat engages valve member 126 to form an operable seal
30
35

therebetween. The insertion and assembly of valve seat member 128 is configured to compress spring 124 by a selected amount to provide a closure force within the range of about 0.25 - 1.0 pounds^(114g - 454g). The spring constant within spring 124 and the amount of compression of the spring are selected to provide the desired amount of closure force. The closure force is great enough to form an effective seal between valve member 126 and valve seat 128 but is low enough such that the work material under an applied pressure of about 100 psi (about 689 kPa) is sufficient to displace valve member 126 away from valve seat 128 and allow the passage of molten work material into valve chamber 130. As a result, when pressure is applied to the supply of work material the valving system will open and allow the extrusion filamentary material from extrusion passage 65. When the pressure to the work material is sufficiently reduced, spring 124 can urge the valving system closed and stop the supply of molten material into chamber 130. As a result, at those times when the supply of molten material is intended to be cut off, the undesired dripping and drooling of molten material from extrusion passage 65 can advantageously be reduced.

During the operation of a representative system, the selected hot-melt adhesive is heated to its molten state and supplied from a conventional reservoir. Suitable adhesives can include, for example, 34-5522 or 34-5510 adhesive supplied by National Starch and Chemical Corp., or other hot-melt adhesives having equivalent properties. The adhesive is heated to a temperature sufficient to allow the molten adhesive to be pumped and extruded through the nozzle units. In the illustrated embodiment, the hot-melt adhesive is heated to a temperature of about 275 - 400°F (about 135 - 204°C), and the molten adhesive is metered and pumped through suitable conduits and delivered to transfer plate 44.

Referring to Fig. 12, a conventional single-stream metering pump 31 delivers molten adhesive from a reservoir tank 17 through supply line 37 to a common manifold 45 located at nozzle assembly 10. Pump 31 is suitably sized and configured to supply and pressurize the adhesive held in manifold 45. Excess pressure in manifold 45 is released through pressure relief valve 35, which directs and recirculates the released adhesive through adhesive return line 39



back to the reservoir tank. In the shown embodiment, the relief valve is adjusted to maintain in manifold 45 an adhesive pressure which is within the range of about 10-35 psi.

5 A plurality of conventional pumps draw molten adhesive from manifold 45, and deliver individual metered streams of adhesive to each nozzle unit 24. The shown embodiment of the invention employs a plurality of multistream metering pumps 33, which are configured to deliver individual selected amounts of molten adhesive at predetermined rates to the nozzle units. More particularly, each
10 multistream metering pump 33 can be a commercially available, four-stream metering pump which is capable of delivering precisely measured amounts of adhesive through independent porting and conduits to transfer plate 44, and then through independent conduits 84 to four individual nozzle units. For example, the shown embodiment of the invention employs six, four-stream metering pumps 33 to supply
15 molten adhesive to two nozzle banks 20, 22, wherein each nozzle bank comprises twelve individual nozzle units 24. It is readily apparent, however, that additional metering pumps could be employed to supply adhesive to additional nozzle units. Also, different size metering pumps 33 could be employed configured to deliver greater or less than
20 four metered streams from each pump. Any such changes or modifications are contemplated as being within the scope of the invention.

If one or more of the metered streams of adhesive goes to a
25 nozzle location which has been closed with a plug 100 (Fig. 5), adhesive will travel through return ports 62, through transfer plate 44 into manifold 45, and then recirculate to reservoir 17. Similarly, if a nozzle unit should become plugged, the nozzle unit includes a mechanism for venting excess pressure and adhesive through
30 adhesive return ports 62.

The configuration of the invention can advantageously provide a substantially uniform and substantially equalized flow of adhesive from each of the nozzle units. The invention can also provide a more precise control of the adhesive deposition patterns onto the chosen
35 substrate. In one aspect of the invention, the flow rate of adhesive from each of the nozzle units can be regulated to have a variation of not more than about plus or minus 5%. In further aspects of the

invention, the adhesive flow rate is preferably controlled to have a variation of not more than about plus or minus 2%, and more preferably, is controlled to have a variation of not more than about plus or minus 1% to provide improved performance. Thus, the invention can produce a more uniform array of adhesive deposition patterns over the surface of the substrate, and the resultant, more uniform distribution of adhesive add-on can thereby produce more uniform bonding of the final product with improved product integrity.

Suitable metering pumps for use with the invention are manufactured by various commercial vendors. The four-stream metering pump 33 can, for example, comprise an Acumeter MBE-HA manifold pump coupled to a #15747 front-pump mechanism and a #15668 drive-pump mechanism. The various pump mechanisms can be connected to an Acumeter assembly which provides a manifold for incoming adhesive and provides a distribution system for the individual streams of adhesive metered from the pump mechanisms. Acumeter, Inc. is a company having facilities in Marlborough, Massachusetts.

Typically, metering pumps 33 can deliver hot-melt adhesive at a pressure of not more than about 1000 psi (about 6894 kPa). In the illustrated embodiment, metering pumps 33 deliver hot-melt adhesive to the transfer plate and nozzle units at a pressure within the range of about 250 - 750 psi (about 1724 - 5170 kPa). The liquid hot-melt adhesive flows from the metering pumps into transfer plate 44 through porting located in manifold 45 and then through passages 84 into nozzle plate 32, where the adhesive is introduced into the individual bore holes 48. From bore 48, the molten adhesive flows into supply passage 64 and proceeds through nozzle body 50 into extrusion passage 65 of head button 80. The molten adhesive is then expelled through each of the individual nozzle units 24 in a generally continuous stream. In a particular aspect of the invention, the molten adhesive is delivered from each nozzle unit at a flow rate of about 2 - 20 gm./min. Preferably, the molten adhesive is delivered at a rate of about 9 - 15 gm./min., and more preferably is delivered at a rate of about 12.3 gm./min. to provide an improved deposition pattern.

To provide improved process control, Fig. 3 representatively shows an embodiment in which nozzle plate 32 is heated with a

suitable heating mechanism 34, such as a Model E1078 heater produced by Acumeter, Inc. The heater is adjusted to maintain the nozzle plate at a temperature of about 270 - 400°F (about 132 - 204°C), and more preferably is maintained at a temperature within the range of about 290 - 320°F (about 143 - 160°C) to provide improved processing. A conventional thermostat 29 can be employed to help regulate the temperature. Since the nozzle plate is in close contact with transfer plate 44 and nozzle units 24, it will be readily apparent that heater 34 can operably heat the transfer plate and nozzle units, as well as the nozzle plate. While the shown embodiment incorporates three heaters 34, other numbers of individual heating units may also be employed.

As the hot-melt adhesive is extruded from the nozzle units, heated air is introduced into transfer plate 44 through gas inlet 36 (Fig. 3) from a conventional supply 19 (Fig. 13) of pressurized air. A suitable device 41 for heating the air is a Model GCH-1XT manufactured by Chromalox located in Ogden, Utah. In the illustrated embodiment of the invention, the air is heated to a temperature of about 250 - 400°F (about 121 - 204°C), and preferably is heated to a temperature of about 290 - 320°F (about 143 - 160°C) to provide improved process control. The heated air is conducted into nozzle plate 32 and delivered to gas inlet port 68, as shown in Fig. 4. From the gas inlet port, the heated air passes through the expanded region 70 of bore 48 and then into gas passage 74, through which the air is introduced into the transfer space defined by groove 76. The air then passes through outlet passage 63 which directs the gas into an airstream having both a circumferential velocity component and an axial velocity component. The resultant airstream operably engages and entrains the stream of molten adhesive issuing forth from the exit of extrusion passage 65, and operably imparts a swirling, generally circular component of motion to the liquid adhesive stream. In a particular aspect of the invention, the airstreams are configured to cooperate and operably entrain the adhesive stream without excessively disrupting its substantially continuous, filamentary configuration. Consequently, as the molten adhesive moves toward substrate web 14, the adhesive stream traverses along a

generally spiral or helical path having both a circumferential as well as an axial component of motion.

5 With reference again to Fig. 1, the invention is configured to move substrate web 14 at a selected speed along a predetermined machine direction 27 of the apparatus. As a result, the adhesive stream can be deposited onto web 14 in a curvilinear pattern. The deposited pattern of adhesive can be adjusted by regulating the movement speed of web 14, by regulating the circumferential and axial velocity components imparted to the adhesive stream, and by adjusting
10 the distance between nozzle section 80 and web 14.

The technique of the present invention includes suitable driving means, such as electric motors (not shown), for rotating the conveyor rollers at a speed sufficient to impart a desired transporting speed to web 14. High web speeds are desired to improve manufacturing efficiency, but at high web speeds, conventional adhesive spraying systems have not been able to maintain satisfactory control over the adhesive deposition patterns. In contrast to such conventional techniques, the method and apparatus of the present invention can produce accurate adhesive deposition patterns at web speeds of at least about 350 ft./min. ^(105 m/min) In further aspects of the invention, sufficiently accurate and precise control of the deposition patterns can advantageously be maintained at web speeds of at least about 450 ft./min. ^(140 m/min) and even at web speeds of at least about 600 ft./min. ^(180 m/min) The shown embodiment may, for example, provide a web speed of about 800 ft./min. ^(245 m/min) and may further provide a web speed of up to about 1,000 ft./min. ^(300 m/min).
15
20
25

In a particular aspect of the invention, the method and apparatus can be adjusted to deposit each individual stream of hot-melt adhesive swirled into a looping, semi-cycloidal pattern. In the general sense, a cycloid is the path traced by a point on the peripheral circumference of a wheel as the wheel rolls over a flat surface without slippage. If, however, there is slippage between the surface and the rolling wheel, the point on the circumference of the wheel will trace a path having a retroceding section which forms a loop in the traced path. The semi-cycloidal pattern representatively shown in Fig. 10 is similar in form to the path traced by the point on the wheel where the wheel is rolling with slippage. As a result,
30
35



each semi-cycloidal pattern has a retroceding loop section 92 traced by the deposited hot-melt adhesive.

It has been discovered that a generally continuous, semi-cycloidal pattern of adhesive can be produced by suitably controlling the air pressure supplied to the individual nozzle units. Accordingly, a particular aspect of the invention includes a gas pressure regulator 18, such as a Model R11 manufactured by C. A. Norgren Co. having facilities in Littleton, Colorado. The pressure regulator is constructed to be capable of delivering about 80 psi (about 551 kPa) of air pressure. In a particular aspect of the invention, the pressure regulator is configured to provide not more than about 32 psi (about 221 kPa) of air pressure, and preferably is configured to provide air pressure within the range of about 12 - 32 psi (about 82.7 - 221 kPa). In the shown embodiment, about 25 psi (about 172 kPa) of air pressure is provided to the nozzle unit. Too low an air pressure, such as a pressure below about 12 psi (about 82.7 kPa), may not produce the desired loop deposition pattern at the selected adhesive throughput rate. Instead, the pattern can have the appearance of a wavy line and can provide inadequate distribution and coverage of adhesive over the surface area of the substrate. If the supplied air pressure is too high, the deposited pattern of adhesive may suitably cover the surface of the web, but the airstreams can excessively scatter the positioning of the adhesive. As a result, the cross-directional positioning of the adhesive will be inaccurate and there can be excessive overspray which would contaminate the equipment and waste adhesive.

A particular aspect of the invention can include separate, gas pressure regulators for nozzle banks 20 and 22, as representatively shown in Fig. 13. Such an arrangement may be especially useful when the individual nozzle banks have unequal numbers of nozzle units 24. For example, first nozzle bank 20 may have thirteen nozzle units, and second nozzle bank 22 may have twelve nozzle units. In such a situation, the separate gas flow regulators may be adjusted to supply different amounts of gas to the different nozzle banks. More particularly, less gas could be supplied to the nozzle bank having fewer nozzle units to fine tune the system.

In the embodiment shown in Fig. 13, air or other suitable gas is delivered from a designated gas supply 19 through control valve 18 into gas heater 41. The heated air then travels through an insulated supply line 43 to a distribution manifold 73 which splits the heated
5 air into four individual air streams. Two air streams are directed to nozzle plate 32 through air conduits 49 and 51 to supply heated air to nozzle bank 20. Two other air streams are directed to the nozzle plate through air conduits 53 and 55 to supply heated air to second nozzle bank 22. Gas flow control valves 57 and 59 are
10 constructed and arranged to regulate the flow of heated air through conduits 49 and 51, respectively.

It has also been discovered that the distance between nozzle units 24 and web 14 is an important parameter for providing the desired semi-cycloidal deposition pattern. Accordingly, in one
15 aspect of the invention, the distance between the exits from nozzle extrusion passages 65 and the position of web 14, as it moves over rollers 16, is limited to a maximum separation distance 98 (Fig. 1A) of about 2 in. ^(5 cm). Preferably, the separation distance is not more than about 1.75 in. ^(4.5 cm), and more preferably, the separation distance is
20 within the range of about 1.0 - 1.5 in. ^(2.5 - 3.8 cm) to provide improved control over the deposition patterns. The reduced separation distance, for example, can reduce the chances of disrupting the desired deposition patterns with extraneous side currents of air or other windage.

With the shown embodiment of the invention, the semi-cycloidal pattern from each nozzle has a cross-directional extent or width 91
25 (Fig. 11) of about 0.5 - 0.75 in. (about 1.27 - 1.9 cm.). In addition, the individual spacing 95 between adjacent loops of the adhesive pattern, as measured along the machine direction, is within the range of about 0.5 - 2.0 cm. Preferably, the machine direction
30 spacing between loops is about 0.7 - 1.4 cm., and more preferably is about 0.8 - 1.0 cm. to provide improved bonding characteristics. If the spacing is too small, an excessive amount of adhesive will be expended, and if the spacing is too great, the adhesive pattern may provide inadequate bonding strength.

35 In one aspect of the invention, the method and apparatus are constructed and arranged to form an array composed of a plurality of juxtaposed, semi-cycloidal patterns of hot-melt adhesive, as



representatively shown in Fig. 11. In a further aspect of the invention, the juxtaposed semi-cycloidal patterns are arrayed in a configuration wherein two or more adjacently located, semi-cycloidal patterns contact each other along adjacent marginal side sections 94, 96 thereof. For example, the adjacently located patterns of hot-melt adhesive may contact each other along a substantially continuous line which extends along machine direction 27 of web 14. Accordingly, the plurality of semi-cycloidal patterns illustrated in Fig. 11 contact one another along substantially continuous, generally parallel lines which extend along the longitudinal, machine direction 27.

To produce the desired array of adhesive patterns on web 14, a plurality of nozzle units are selectively positioned along the cross-direction 26 of the apparatus. More specifically, the incorporation of each additional nozzle unit can effectively add another semi-cycloidal pattern of adhesive and thereby incrementally increase the cross-directional width of web 14 which is covered with adhesive.

It has, however, been discovered that a conventional, linear arrangement of the individual nozzle units 24 along cross-direction 26 may not produce the desired deposition array of adhesive. It has been found that the group of airstreams issuing forth from one nozzle unit 24 would excessively interfere with the group of airstreams issuing forth from an adjacent nozzle unit. As a result, the desired array of juxtaposed semi-cycloidal patterns can be disrupted and the bonding effectiveness can be excessively reduced.

One technique for addressing this problem has been to increase the cross-directional spacing between adjacent nozzle units. Such a technique, however, can leave undesirable gap regions between adjacent patterns of deposited adhesive. The gap regions would then be unbonded to the completed assembly, and would have lower strength and poorer integrity.

The structure and arrangement of the present invention provides an improved configuration which more effectively reduces the interaction between adjacent groups of airstreams and more effectively reduces the interference between adjacent streams of

adhesive. In particular, the invention can be advantageously configured with the nozzle units 24 arranged in the alternating, offset and staggered arrangement previously discussed with reference to Fig. 2. As representatively shown in Fig. 2, the individual nozzle units 24 are grouped into a first nozzle bank 20 and a second nozzle bank 22. Within first nozzle bank 20, for example, the adjacent nozzle units 24a and 24b are spaced apart by a cross-directional distance which is sufficient to substantially prevent adjacent groups of airstreams from interfering with each other, and also to substantially prevent adjacent swirling streams of hot-melt adhesive from interfering with each other as they traverse from the nozzle units to the web substrate. Accordingly, the cross-directional separation 88 between adjacent nozzle units 24a and 24b should be not less than about the average of the widths 91a, 91b (Fig. 11) of the associated, adjacent semi-cycloidal patterns produced by these nozzle units. In the shown embodiment, the cross-directional spacing between nozzle units 24a and 24b is approximately equal to two times the width 91 of one of the semi-cycloidal patterns 90. Fig. 2 representatively shows a particular nozzle bank having individual nozzle units 24 which are substantially equally spaced along the cross-direction, but an unequal cross-directional spacing between adjacent nozzle units could also be employed.

The configuration of second nozzle bank 22 is similar to the configuration of first nozzle bank 20. The second nozzle bank, however, is offset from the first nozzle bank along the machine direction by an offset distance 23 sufficient to substantially prevent the airstreams from the first nozzle bank from interfering with the airstreams from the second nozzle bank, and to substantially prevent the motions of the adhesive streams from the first nozzle bank from interfering with the motion of the adhesive streams produced by the second nozzle bank. In the illustrated embodiment, the machine direction offset 23 is at least about 3.0 cm., and preferably is at least about 4.0 cm. to provide improved performance.

In addition to being offset in the machine direction, the nozzle units in second nozzle bank 22 are staggered in the cross-direction relative to the nozzle units in first nozzle bank 20. As can be seen

in Fig. 2, the individual nozzle units comprising second nozzle bank 22 are positioned in the cross-directional gaps which separate the individual nozzle units comprising first nozzle bank 20. As a result, the nozzle banks 20, 22 in combination can provide a substantially complete coverage of adhesive over web 14 while substantially preventing undesired interaction or interference between the air streams and adhesive streams produced by the individual nozzle units 24. The invention can thereby advantageously provide a consistent deposition pattern from each of the nozzle units 24, and can provide a more accurate cross-directional positioning of the adhesive patterns on web 14. In one aspect of the lateral side edge 94 of one or more of the semi-cycloidal adhesive patterns 90 has a cross-directional variation of not more than about plus or minus 0.125 in_λ ^(0.318 cm) relative to a predetermined desired position along the cross-direction. Preferably, the cross-directional positioning variation is not more than about plus or minus ^(0.16 cm) 0.063 in_λ, _(0.08 cm) and more preferably is not more than about plus or minus 0.032 in_λ to provide improved performance.

The offset and staggered relationship between first nozzle bank 20 and second nozzle bank 22 can also provide the capability to selectively adjust an amount of overlap 93 (Fig. 11) between adjacent, semi-cycloidal patterns of adhesive. For example, the individual nozzle units within first nozzle bank 20 can have substantially equal cross-directional separations 88 which are between about 1-2 times an average pattern width 91. The individual nozzle units within second nozzle bank 22 can then be configured with similar cross-directional separations, and the second nozzle bank can be offset in the machine direction from the first nozzle bank. In addition, the nozzle units within second nozzle bank 22 can be staggered with respect to the nozzle units within first nozzle bank 20. Stagger distance 87, for example, can be adjusted to be about one-half of separation distance 88, and the apparatus can be arranged to have the nozzle units produce adhesive patterns of substantially equal width 91. As a result of this particular configuration, the apparatus can produce an array of multiple, semi-cycloidal adhesive patterns wherein the adjacent patterns overlap by a discrete distance 93. For example, a particular aspect



of the invention provides an overlap distance 93 within the range of about 0.125 - 0.25 in. (about 0.32 - 0.63 cm.) to thereby produce a desired combination of good bonding strength and economy of adhesive add-on.

5 The illustrated embodiment of the invention representatively shows a configuration wherein the nozzle units that respectively form immediately adjacent deposition patterns are arranged in a substantially "zig-zag" layout. In an alternative embodiment of the invention, the desired offset and staggered arrangement of the individual nozzle units may be accomplished by positioning three or more nozzle units substantially along a line which extends diagonally across the machine-cross direction. A nozzle bank having such a construction could be rotated to adjust the angle of the diagonal to control the amount of overlap 93 between adjacent deposition patterns 91.

10
15
20 Another advantage afforded by the present invention is an ability to incrementally reduce the total width of the area covered by the array of deposited adhesive patterns. More particularly, the total width of the web area, which is occupied by the deposited adhesive can be adjusted by selectively removing nozzle units and capping off the corresponding, associated bore holes 48 with a plug mechanism 100.

25
30
35 As representatively shown in Fig. 5, plug 100 is substantially cylindrical in shape and includes an annular flange 102 formed at one end thereof. Flange 102 is constructed and arranged to sealingly engage surface 54 of nozzle plate 32 and to effectively cover the opening of the bore hole 48. Gasket member 40 provides a substantially airtight seal between surface 54 and flange 102. The gasket is composed of a conventional fibrous gasket material, and is configured to reduce air leaks caused by irregularities in the mating surfaces. A cylindrical body section 104 of the plug extends into bore 48 and includes a circular groove configured to accommodate therein a sealing means, such as O-ring 108. O-ring 108 is positioned between adhesive return port 62 and the expanded region 70 of bore hole 48. In addition, the axial length of plug body 104 is selected so as to stop short of the position of adhesive return port 62. As a result, hot-melt adhesive is able to recirculate from

bore 48 through adhesive return port 62 and return to a suitable reservoir accumulator.

In a further aspect of the invention, the method and apparatus include a pressure release means for relieving excessive pressure built up behind a partially or completely plugged nozzle orifice. Referring to Fig. 4, O-ring 61 is constructed and arranged to bypass excessive pressure which might build up behind a plugged nozzle orifice. In particular, O-ring 61 is constructed and arranged to operably deflect to allow the passage of pressurized adhesive from bore hole 48 past the position of O-ring 61 and into adhesive return port 62. In the illustrated embodiment, O-ring 61 is constructed to operably deflect when subjected to an adhesive pressure of more than about 1400 psi. As a result of the configuration of O-ring 61 and the positioning of adhesive return port 62, the invention can substantially prevent the undesired backing of adhesive into the air system comprising expanded section 70 and gas inlet port 68. The distinctive configuration of the invention can thereby reduce unanticipated maintenance of the system.

The present invention can be employed to produce distinctive manufactured articles, such as disposable garments, infant diapers, feminine care products, incontinence products and other adhesively bonded assemblies. More particularly, the present invention can be employed to produce distinctive absorbent articles, such as disposable diaper 110.

With reference to Fig. 14, disposable diaper 110 includes an outer layer 112, a bodyside layer 114 and an absorbent body 116 sandwiched between the outer and bodyside layers. The outer and bodyside layers extend outwardly past the side edges of absorbent body 116 to form side seals and side flaps or cuffs, which are constructed to contact and sealingly engage the thighs of the wearer. In certain arrangements, leg elastics are positioned in the side flaps to produce elasticized gathers, which can provide improved sealing and leakage prevention around the wearer's legs and improved fit. In addition, the outer and bodyside layers may extend beyond the longitudinal edges of absorbent body 116 to form waistband portions of the diaper, and waist elastics 120 may be assembled into the waist band portions. Absorbent body 116 may comprise one or more

layers of high wet-strength tissue wrapped around an absorbent core composed of a mixture of woodpulp fluff and superabsorbent particles. A representative diaper article is described in U.S. Patent 4,699,823 issued October 13, 1987 to S. Kellenberger, et al., which is hereby
5 incorporated by reference to the extent it is consistent with the present disclosure.

Diaper 110 includes an array of adhesive arranged to secure one or more of the layers to the absorbent body. The adhesive array is distinctively composed of a plurality of juxtaposed, semi-cycloidal
10 patterns of adhesive which extend substantially along a longitudinal dimension of the article. For example, outer layer 112 may be secured to absorbent body 116 by the array of semi-cycloidal patterns of adhesive. Alternatively, the array of adhesive may be employed to secure bodyside layer 114 to the absorbent body. Similarly, the
15 array of adhesive may operably secure outer layer 112 to bodyside layer 114, or secure the tissue wrap to the absorbent core. In the illustrated embodiment, an adhesive array composed of a plurality of juxtaposed, semi-cycloidal patterns of adhesive is applied with the adhesive patterns extending substantially along the lengthwise
20 dimension of the article. In addition, the adjacent patterns of the adhesive contact each other along adjacent, marginal side portions of the semi-cycloidal patterns. The shown embodiment of diaper 110 includes adjacent patterns of adhesive which contact each other along substantially continuous, generally parallel lines which extend along
25 the longitudinal dimension. Alternatively, the adjacent semi-cycloidal patterns may overlap each other along the side margins of the individual patterns.

The amount of adhesive distributed over outer layer 114 is within the range of about 1.0 - 6.0 gm. per square meter.
30 Preferably, the amount of adhesive add-on is within the range of about 4.0 - 5.0 gm. per square meter to provide more improved efficiency. When compared to the amount of adhesive add-on employed with construction adhesive applied in the pattern of generally linear, parallel lines of adhesive, the amount of adhesive
35 incorporated into the distinctive patterned array of the invention can be decreased to about 50% of the conventional amount of adhesive. Even though the amount of adhesive employed is reduced, the

distinctive adhesive distribution provided by the present invention can adequately maintain the integrity of the final product. In particular, when compared to the conventional, parallel adhesive line construction technique, the bonding strength at end seal region 122 can be substantially maintained even though the amount of adhesive add-on is reduced. For example, the amount of adhesive may be reduced from about 0.94 gm./diaper to about 0.54 gm./diaper and still maintain approximately the same end seal strength. In addition, the distribution of the adhesive in the distinctive patterns and arrays of the invention can advantageously provide a more flexible outer cover layer which has a more pleasing cloth-like appearance and feel.

A representative comparison of the end seal strengths and the amount of adhesive add-on is set forth in the graph shown in Fig. 15. The graph representatively shows data generated from medium-size disposable diapers, constructed with a conventional hot-melt construction adhesive. More particularly, the diapers were constructed with National Starch 34-5522 or 34-5510 adhesive. When compared to conventional, generally parallel adhesive lines, the looping-type adhesive patterns produced in accordance with the present invention can advantageously provide increased end-seal strengths at the same amounts of adhesive add-on. Alternatively, the adhesive patterns produced in accordance with the present invention can advantageously provide the same end-seal strengths with lower amounts of adhesive add-on.

For the purposes of the present invention, the following procedure is a suitable technique for determining the end seal strength:

A test specimen is prepared by cutting a rectangular sample measuring 3 in. x 5 in. ^(7.6 x 12.7 cm) from the center of the waistband section of the diaper. One 3 in. ^(7.6 cm) side of the sample corresponds to the terminal waistband edge, and the two 5 in. ^(12.7 cm) sides extend along the longitudinal length of the diaper. The fluff pad material is then removed from the sample without disturbing the patterns of adhesive in the end seal region of the sample. The end seal region is the portion of the sample wherein the bodyside liner is adhesively bonded or otherwise attached and laminated with the outer cover layer. The end seal strength corresponds to the force required to peel apart the bond



between the liner and outer cover, and is expressed in terms of peak load measured in grams (gram-force). The apparatus employed to measure the end seal strength is an Instron tensile tester with a 10 kilogram load cell, or equivalent tensile testing apparatus, in conjunction with a Microcon microprocessor apparatus. The Microcon device analyzes input data to provide, for example, load vs. elongation plots and Total Energy Absorption information from the test sample, and is distributed by Instron Corp. having facilities at Canton, Massachusetts. The Instron tensile test apparatus is set with a cross-head speed of 10 inches per minute and a chart speed of 2 inches per minute. The jaw spacing of the Instron apparatus is set at 4 inches. The Microcon apparatus is initialized to the following set of conditions:

Initial sample length = 4 inch (gauge length) (10.2 cm)

Cross-head speed = 250 mm/min (10 inch/min).

Automatic return = 10 inch (250 mm)

Print mode = peak load, break energy

The test sample will have a generally "Y" configuration wherein the end seal portion corresponds to the base of the Y, the liner material corresponds to one arm of the Y, and the outer cover material corresponds to the second arm of the Y. The two arms of the sample are secured in the jaws of the Instron apparatus with the inside of the sample facing toward the front of the Instron apparatus and the outer cover material held in the moveable jaw. The line of separation between the outer cover material and the liner material is positioned approximately half way between the two jaws. The cross-head motion of the Instron machine is then started, and when the sample has been completely peeled apart, the highest average peel force applied to the test sample is recorded.

Having thus described the invention in rather full detail, it will be readily apparent that various changes and modifications may be made without departing from the spirit of the invention. All of such changes and modifications are contemplated as being within the scope of the invention, as defined by the subjoined claims.

35



The claims defining the invention are as follows:

1. An apparatus for forming a substantially continuous filament of a thermoplastic work material and imparting a swirling motion thereto, comprising:

5 a body member which has a work material supply passage and a gas supply passage formed therein, said gas supply passage substantially aligned with and generally radially spaced from a longitudinal central axis of said body member, and said gas supply passage having substantially no inclination along a radial direction toward said central
10 axis of said body member;

an outlet nozzle section which is connected to said body member and has a substantially conically tapered shape, said nozzle section having a nozzle extrusion passage formed therein in communication with said work material supply passage; and

15 a housing member which operably connects to said body member to delimit a substantially annular gas transfer zone in fluid communication with said gas supply passage and to delimit a substantially annular gas outlet passage around said nozzle section and in fluid
20 communication with said gas transfer zone, said housing member including an exit section having inner wall surfaces which substantially parallel the substantially conically tapered shape of said nozzle section, and which are in a selected spaced relation from said nozzle section to define said gas outlet passage, said gas supply passage, said housing
25 exit section and said nozzle section configured to provide for a selected gas flow which imparts said filament swirling motion substantially without disintegrating said filament, said apparatus thereby constructed to deposit a substantially continuous, swirled filament of said work material onto a selected substrate.

2. An apparatus as recited in claim 1, wherein said nozzle
30 section and said housing member are configured to provide an arrangement wherein said gas outlet passage is asymmetrically disposed around said nozzle section.

3. An apparatus as recited in claim 1, wherein said nozzle extrusion passage has a diameter within the range of about 0.046-0.056 cm.

35 4. An apparatus as recited in claim 1, wherein said nozzle extrusion passage has a length-to-diameter ratio of at least about 8:1.

5. An apparatus as recited in claim 1, wherein said nozzle

amg/0735y



extrusion passage has a length-to-diameter ratio of at least about 10:1.

6. An apparatus as recited in claim 1, wherein said nozzle extrusion passage has a length-to-diameter ratio within a range of about 8:1-12:1.

5 7. An apparatus as recited in claim 1, wherein said work material supply passage is substantially aligned with a longitudinal, central axis of said body member.

8. An apparatus as recited in claim 1, wherein said work material supply passage is circumferentially inclined at a selected angle with
10 respect to said longitudinal central axis of said body member.

9. An apparatus as recited in claim 1, wherein said gas supply passage has a length-to-diameter ratio of at least about 9:1.

10. An apparatus as recited in claim 1, wherein said gas supply passage has a length-to-diameter ratio which is within a range of about
15 9:1 to 12:1.

11. An apparatus as recited in claim 1, wherein said gas supply passage is circumferentially inclined with respect to said longitudinal axis of said body member with said inclination angled generally along a circumferential direction of said body member at an angle of not more
20 than about 25 degrees.

12. An apparatus as recited in claim 1, wherein said nozzle section has a cone angle within a range of about 40-50 degrees.

13. An apparatus as recited in claim 1, wherein said inner wall surfaces of said housing member outlet passage are spaced from said
25 nozzle section by a distance within a range of about 0.041-0.046 cm.

14. An apparatus as recited in claim 1, wherein said housing member comprises a cap member which is removably connected to said body member.

15. An apparatus as recited in claim 1, wherein said housing
30 member includes a recess section formed in an outwardly facing surface of said housing member and surrounding said exit section of the housing member.

16. An apparatus as recited in claim 15, wherein said recess section has a radial dimension within a range of about 0.521-0.625 cm.

35 17. An apparatus as recited in claim 15, wherein said recess section has a generally circular side wall arranged in a substantially frusta-conical configuration with a largest diameter thereof positioned

amg/0735y



at an outward surface of the housing member.

18. An apparatus as recited in claim 15, wherein said nozzle section protrudes into said recess section by a selected distance of about 0.013-0.015 cm.

5 19. An apparatus as recited in claim 1, further comprising gas delivering means for providing gas into said gas supply passage of said body member at a pressure of not more than about 32 psi (about 221 kPa).

20. An apparatus as recited in claim 1, wherein said gas delivering means is constructed to provide gas at a pressure within a
10 range of about 12-32 psi (82.7-221 kPa).

21. An apparatus as recited in claim 1, further comprising work material delivering means for providing work material to said body member at a pressure of not more than about 1000 psi (6894 kPa).

22. An apparatus as recited in claim 1, wherein said work material
15 delivering means is constructed to provide said work material at a pressure within a range of about 250-750 psi (about 1724-5170 kPa).

23. An apparatus as recited in claim 1, wherein said gas supply passage communicates with said gas transfer zone through an opening, and said gas supply passage is radially spaced from said annular gas outlet
20 passage by a spacing distance corresponding to approximately 0.5-0.9 times an effective diameter of said opening.

24. An apparatus as recited in claim 1, wherein said gas supply passage communicates with said gas transfer zone through an opening, and said gas supply passage is radially spaced from said annular gas outlet
25 passage by a spacing distance corresponding to approximately 0.7-0.8 times an effective diameter of said opening.

25. An apparatus as recited in claim 1, further comprising:
a valving chamber formed in said work material supply passage, said chamber having a bottom wall section and an open end portion;
30 a valving member located within said valving chamber;
a valve seating member connected to said body member at said open end portion of said valving chamber; and
forcing means for resiliently urging said valving member against said valve seating member to selectively block a flow of material
35 into said valving chamber.

26. An apparatus as recited in claim 25, wherein said forcing means provides a closure force which allows displacement of said valving

amg/0735y



member from said valve seating member when work material is applied under pressure of about 100 psi (690 kPa).

27. An apparatus as recited in claim 25, wherein said forcing means comprises a spring which engages said bottom wall section and said valving member.

28. An apparatus as recited in claim 27, wherein said spring provides a closure force within a range of about 0.25-1.0 pounds (114-454 g).

29. An apparatus as recited in claim 11, wherein said gas supply passage communicates with said gas transfer zone through an opening, and said gas supply passage is radially spaced from said annular gas outlet passage by a spacing distance corresponding to approximately 0.5-0.9 times an effective diameter of said opening.

30. An apparatus as recited in claim 11, wherein said gas supply passage communicates with said gas transfer zone through an opening, and said gas supply passage is radially spaced from said annular gas outlet passage by a spacing distance corresponding to approximately 0.7-0.8 times an effective diameter of said opening.

31. An apparatus as recited in claim 11, further comprising:
a valving chamber formed in said work material supply passage, said chamber having a bottom wall section and an open end portion;
a valving member located within said valving chamber;
a valve seating member connected to said body member at said open end portion of said valving chamber; and
forcing means for resiliently urging said valving member against said valve seating member to selectively block a flow of material into said valving chamber.

32. An apparatus as recited in claim 31, wherein said forcing means provides a closure force which allows displacement of said valving member from said valve seating member when work material is applied under a pressure of about 100 psi (690 kPa).

33. An apparatus as recited in claim 31, wherein said forcing means comprises a spring which engages said bottom wall section and said valving member.

34. An apparatus as recited in claim 33, wherein said spring provides a closure force within a range of about 0.25-1.0 pounds (114-454 g).

amg/0735y



35. A method for forming a substantially continuous filament of thermoplastic material and imparting a swirling motion thereto, comprising the steps, of:

- (a) supplying a thermoplastic work material to a nozzle section
5 which has a substantially conically tapered shape;
- (b) forming a substantially continuous filament of said work material which exits from said nozzle section;
- (c) delivering a supply of gas through a gas delivery conduit into a substantially annular gas transfer zone which is positioned about a
10 longitudinal central axis of said nozzle section;
- (d) radially spacing said gas delivery conduit from said longitudinal central axis;
- (e) substantially aligning said gas delivery conduit with said longitudinal central axis with substantially no inclination along a
15 radial direction toward said longitudinal central axis;
- (f) exiting said gas from said gas transfer zone through an annular, substantially conically tapered outlet passage which is located about said nozzle section and substantially parallels said conically tapered shape of said nozzle section; and
- 20 (g) moving said gas through said gas delivery conduit, gas transfer zone and outlet passage and past said nozzle section to provide for a selected gas flow which imparts said swirling motion to said filament while substantially avoiding a disintegration of said filament, said method thereby configured to deposit a substantially continuous,
25 swirled filament of said material onto a selected substrate.

36. A method as recited in claim 35, further comprising the step of circumferentially inclining said gas delivery conduit not more than about 25 degrees relative to said longitudinal axis of said nozzle section.

30 37. A method as recited in claim 35, further comprising the step of asymmetrically disposing said gas outlet passage around said nozzle section.

38. A method as recited in claim 35, wherein said forming step (b) further comprises the step of moving said work material through a nozzle
35 extrusion passage having a diameter within the range of about 0.046-0.056 cm.

39. A method as recited in claim 35, wherein said forming step (b)

amg/0735y



further comprises the step of moving said work material through a nozzle extrusion passage having a length-to-diameter ratio of at least about 8:1.

40. A method as recited in claim 39, wherein said forming step (b) further comprises the step of moving said work material through a nozzle
5 extrusion passage having a length-to-diameter ratio of at least about 10:1.

41. A method as recited in claim 39, wherein said forming step (b) further comprises the step of moving said work material through a nozzle
10 extrusion passage having a length-to-diameter ratio within the range of about 8:1-12:1.

42. A method as recited in claim 35, wherein said supplying step (a) further comprises the step of moving said work material through a supply passage which is substantially aligned with said longitudinal central axis of said nozzle section.

15 43. A method as recited in claim 35, wherein said supplying step (a) further comprises the step of moving said work material through a supply passage which is circumferentially inclined at a selected angle with respect to said longitudinal axis.

20 44. A method as recited in claim 35, wherein said delivering step (c) further comprises the step of moving said gas through a gas supply passage having a length-to-diameter ratio of at least about 9:1.

25 45. A method as recited in claim 35, wherein said delivering step (c) further comprises the step of moving said gas through a gas supply passage having a length-to-diameter ratio within the range of about 9:1 to 12:1.

46. A method as recited in claim 35, further comprising the step of providing said nozzle section with a cone angle within the range of about 40-50 degrees.

30 47. A method as recited in claim 35, wherein said exiting step (f) further comprises the steps of exiting said gas from said gas transfer zone through a substantially conically tapered outlet passage which is located between said nozzle section and an inner wall surface of a housing member, and spacing said inner wall surface from said nozzle section by a distance which is within the range of about 0.041-0.046 cm.

35 48. A method as recited in claim 47, further comprising the step of providing said housing member with a recess section which is formed in an outwardly facing surface of said housing member and surrounds an exit

amg/0735y



section of the housing member.

49. A method as recited in claim 48, further comprising the step of forming said recess section with a radial dimension within the range of about 0.521-0.625 cm.

5 50. A method as recited in claim 49, further comprising the step of forming said recess section with a generally circular side wall arranged in a substantially frusta-conical configuration with a largest diameter thereof positioned at an outward surface of the housing member.

51. A method as recited in claim 50, further comprising the step
10 of protruding said nozzle section into said recess section by a selected distance of about 0.013-0.015 cm.

52. A method as recited in claim 35, wherein said delivering step (c) further comprises the step of delivering said gas to said transfer zone at a pressure of not more than about 32 psi (about 221 kPa).

15 53. A method as recited in claim 52, wherein said gas is delivered at a pressure which is within the range of about 12-32 psi (82.7-221 kPa).

54. A method as recited in claim 35, wherein said supplying step (a) further comprises the step of supplying work material at a pressure of not more than about 1000 psi (6894 kPa).

20 55. A method as recited in claim 54, wherein said work material is supplied at a pressure which is within the range of about 250-750 psi (about 1724-5170 kPa).

56. A method as recited in claim 35, wherein said delivering step (c) further comprises delivering said gas to said transfer zone through
25 an opening which is radially spaced from said outlet passage by a spacing distance corresponding to approximately 0.5-0.9 times an effective diameter of said opening.

57. A method as recited in claim 56, wherein said gas is delivered to said transfer zone through a opening which is radially spaced from
30 said gas outlet passage by a spacing distance corresponding to approximately 0.7-0.8 times an effective diameter of said opening.

58. A method as recited in claim 35, wherein said supplying step (a) further comprises the steps of:

moving said work material through a valving chamber which has a
35 bottom wall section and an open end portion; and

resiliently valving said open end portion to selectively block a flow of said work material into said valving chamber.

amg/0735y



59. A method as recited in claim 58, wherein said resilient valving step comprises the step of resiliently providing a closure force which allows movement of work material into said valving chamber when work material is applied under a pressure of about 100 psi (690 kPa).

5 60. A method as recited in claim 58, wherein said resilient valving step resiliently provides a closure force with a spring.

61. A method as recited in claim 60, wherein resilient valving step provides a closure force within a range of about 0.25-1.0 pounds (114-454 g).

10 62. A method for forming a substantially continuous filament of a thermoplastic work material and imparting a swirling motion thereto, comprising the steps of:

providing a body member which has a work material supply passage and a gas supply passage formed therein;

15 connecting to said body member an outlet nozzle section which has a substantially conically tapered shape and has a nozzle extrusion passage formed therein in communication with said work material supply passage; and

operably connecting to said body member a housing member which
20 delimits a substantially annular gas transfer zone in fluid communication with a gas outlet passage around said nozzle section, said gas supply passage arranged in fluid communication with said gas transfer zone and arranged substantially aligned with and generally radially spaced from a longitudinal central axis of said body member, and said gas supply
25 passage having substantially no inclination along a radial direction toward said central axis of said body member, said housing member including an exit section having inner wall surfaces which substantially parallel the substantially conically tapered shape of said nozzle section and which are in a selected spaced relation from said nozzle section to
30 define said gas outlet passage, said gas supply passage housing exit section and said nozzle section configured to provide for a selected gas flow which imparts said filament swirling motion substantially without disintegrating said filament, said method thereby configured to deposit a substantially continuous, swirled filament of said material onto a
35 selected substrate.

63. An apparatus for forming a substantially continuous filament of a thermoplastic work material and imparting a swirling motion thereto

amg/0735y



substantially as hereinbefore described with reference to the accompanying drawings.

64. A method for forming a substantially continuous filament of a thermoplastic work material and imparting a swirling motion thereto
5 substantially as hereinbefore described with reference to the accompanying drawings.

DATED this EIGHTH day of JULY 1992
KIMBERLY-CLARK CORPORATION

10

Patent Attorneys for the Applicant
SPRUSON & FERGUSON

15

19

20

20

25

25

30

30

35

amg/0735y



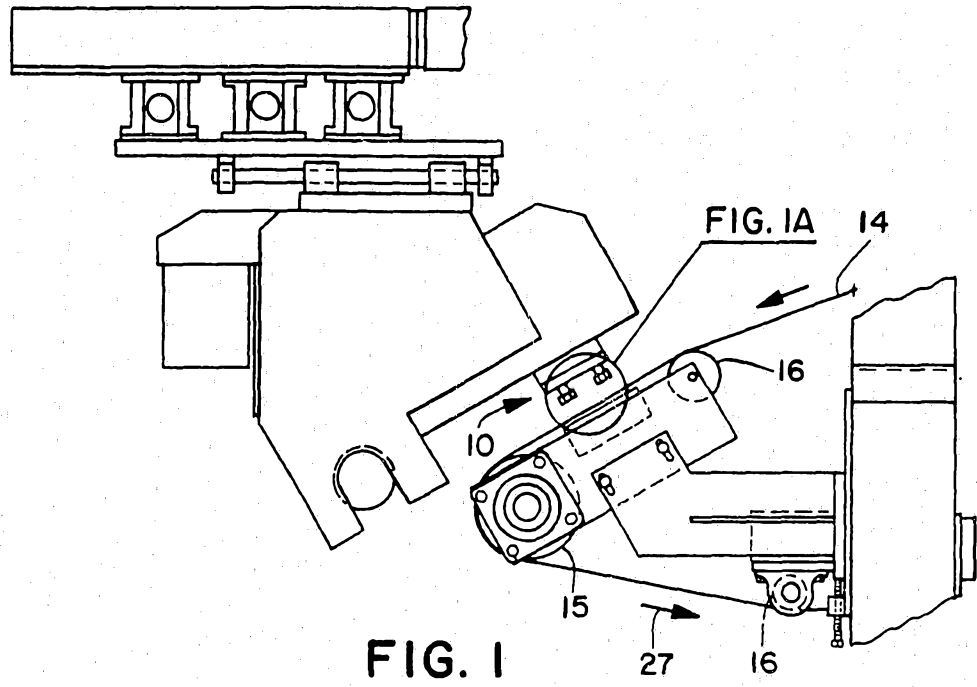

FIG. 1

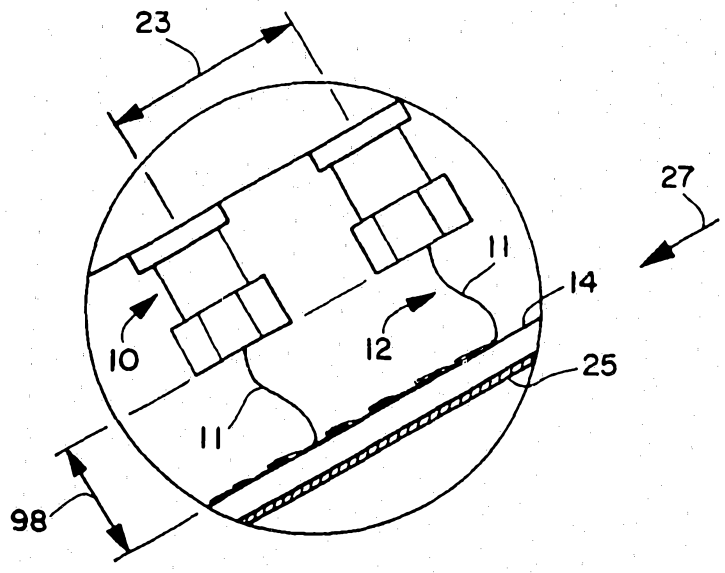

FIG. 1A

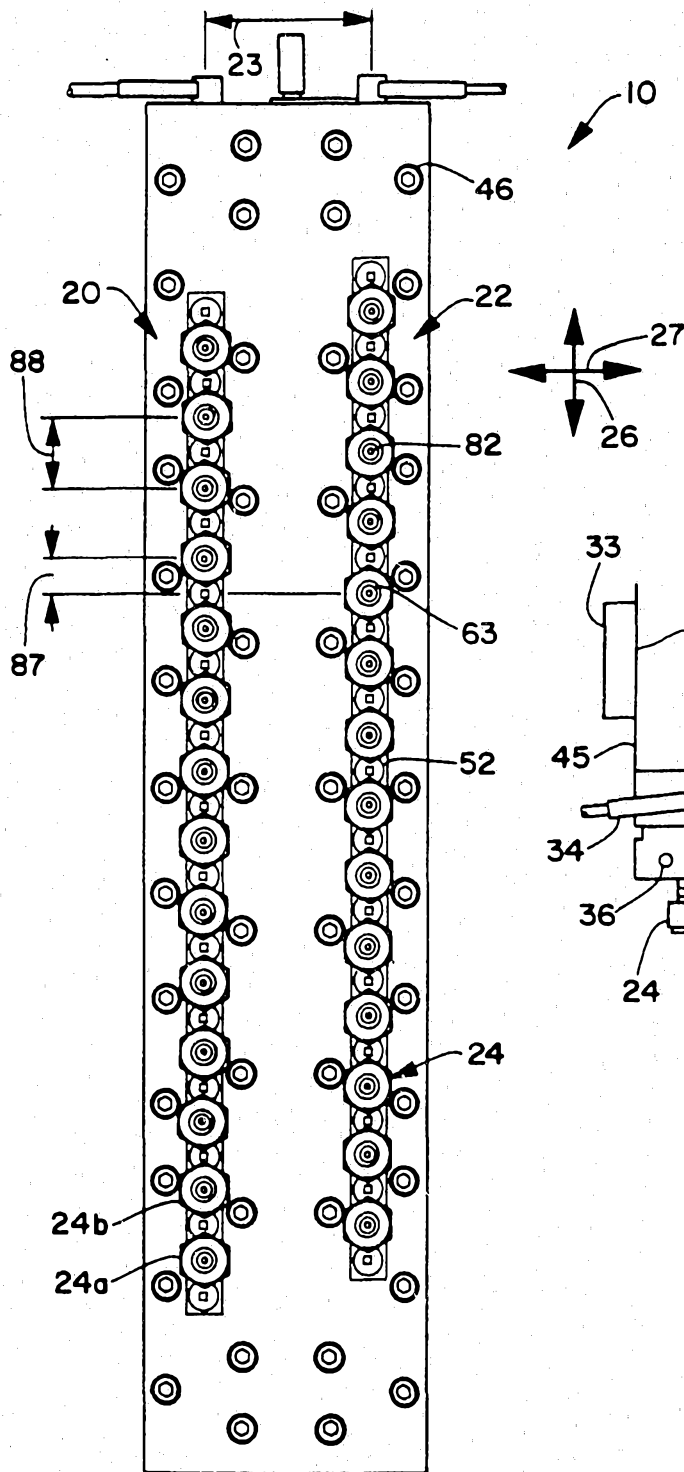

FIG. 2

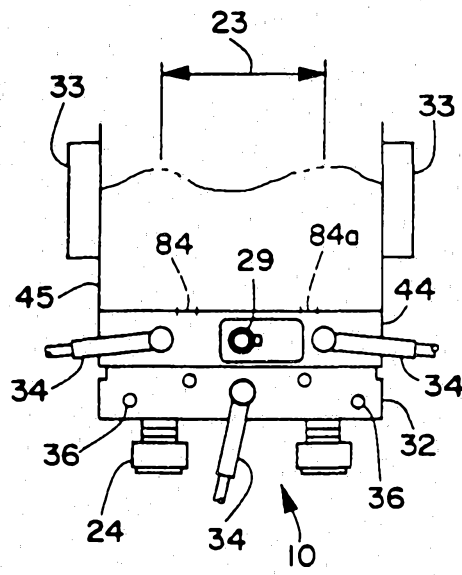

FIG. 3

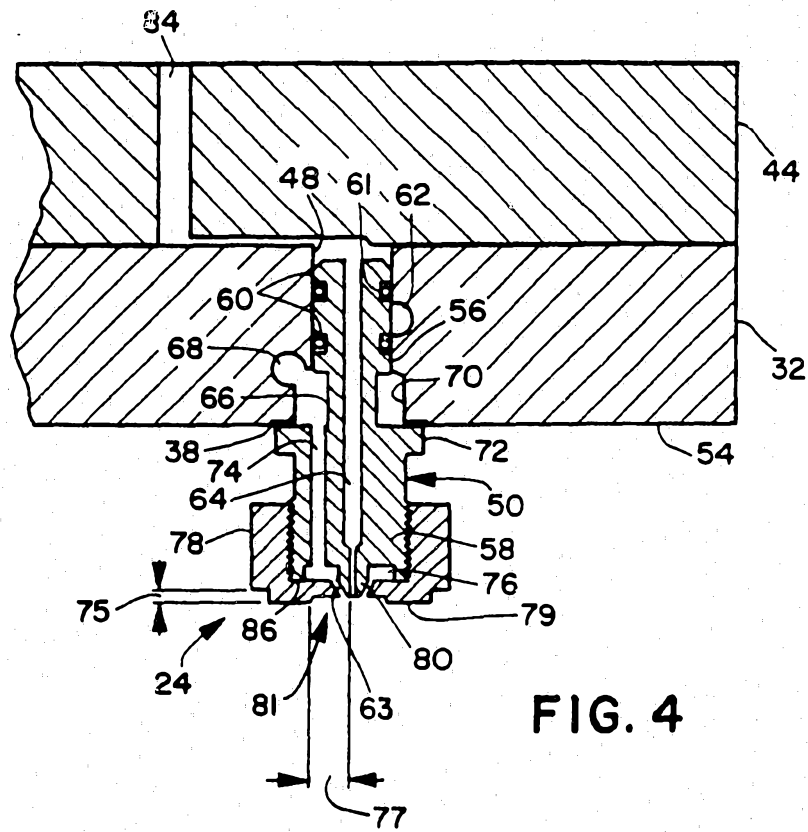

FIG. 4

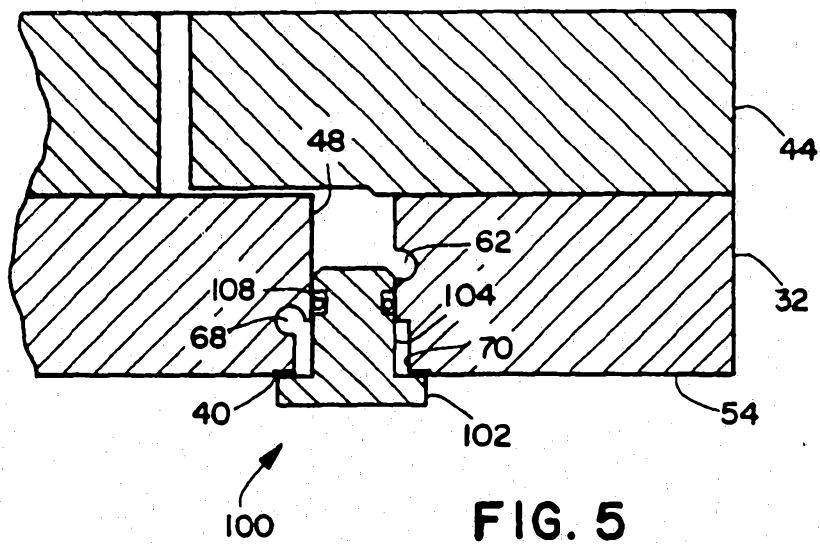
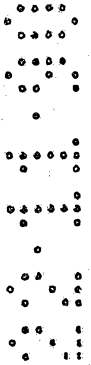
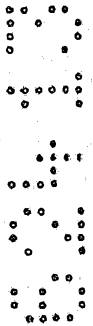

FIG. 5



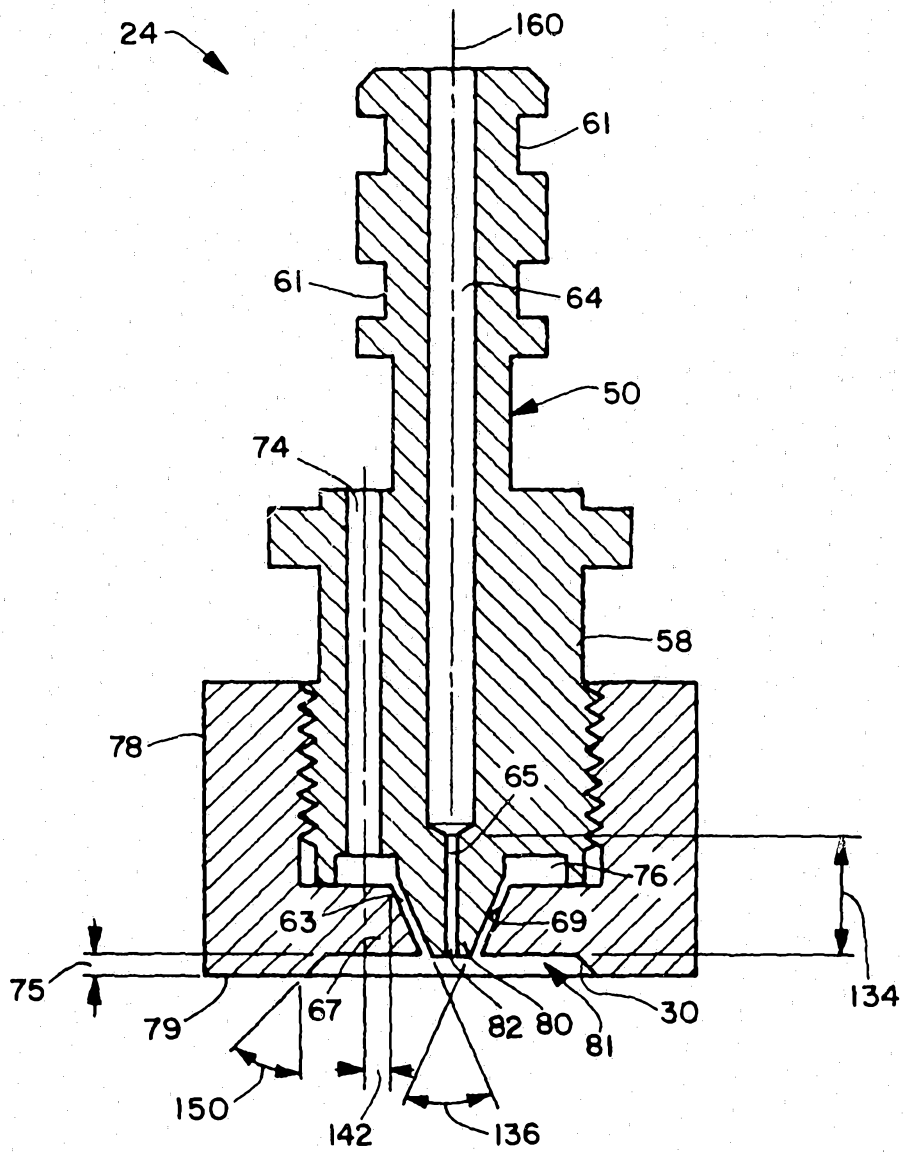

FIG. 6

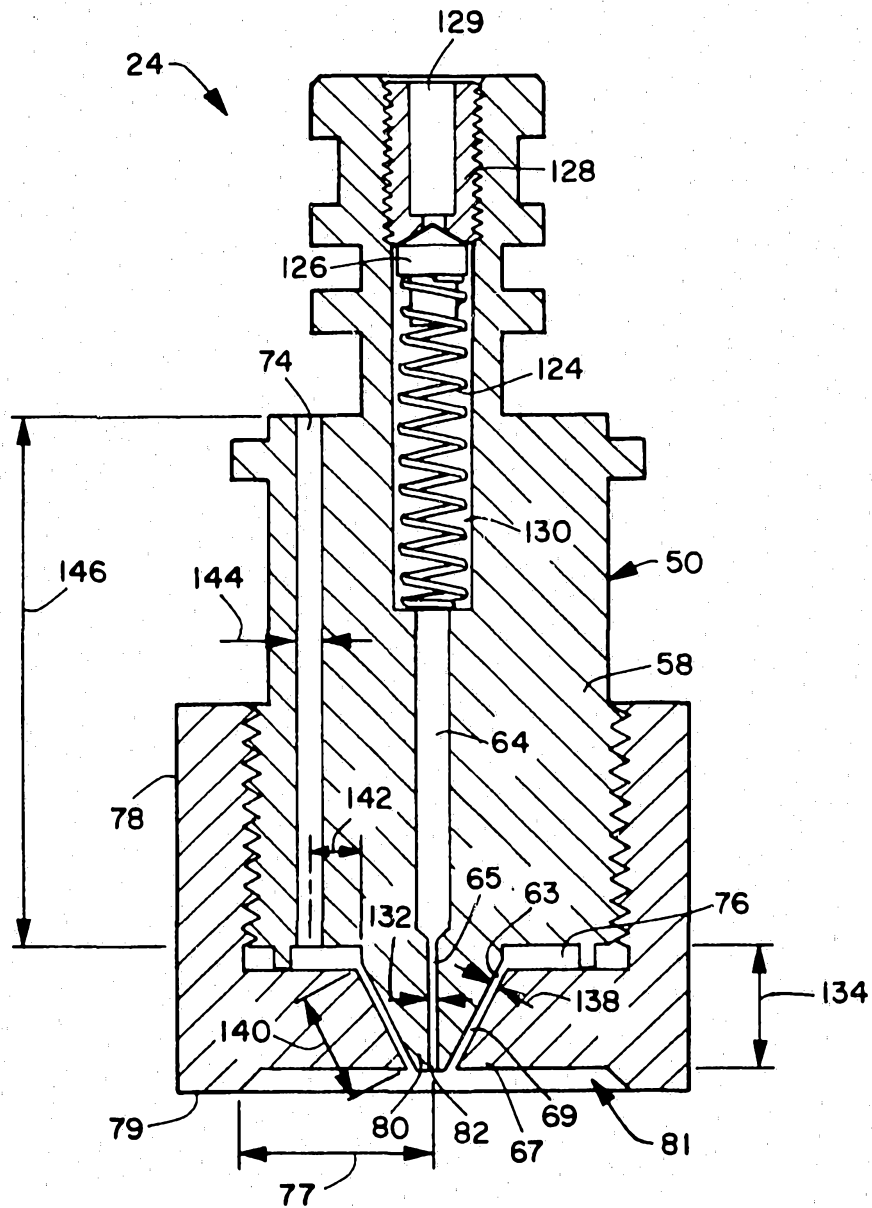

FIG. 7

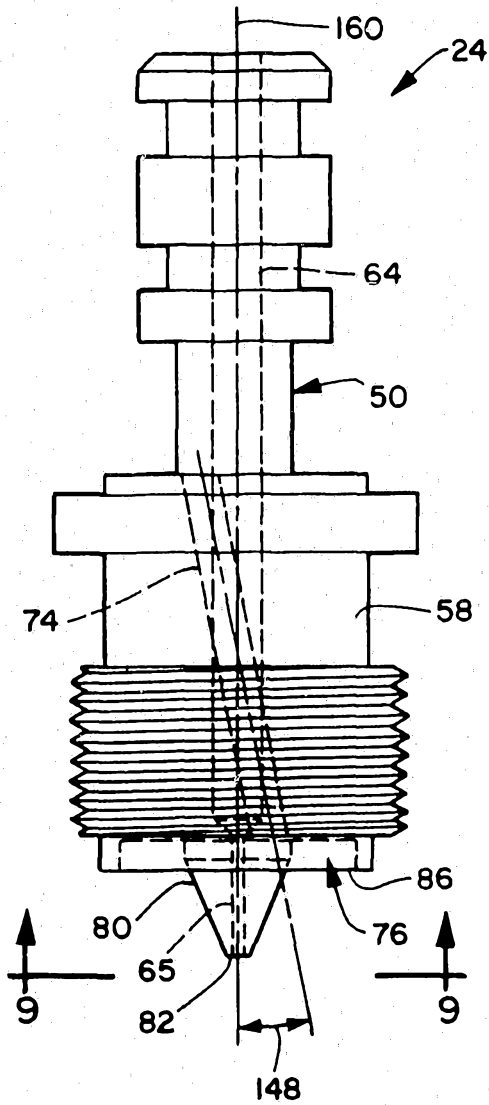

FIG. 8

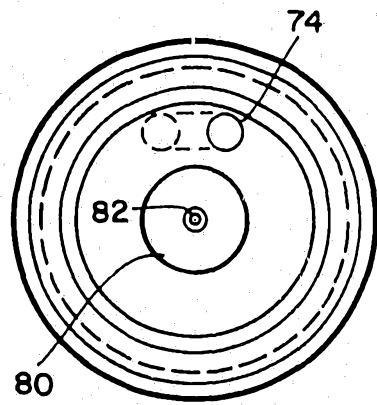
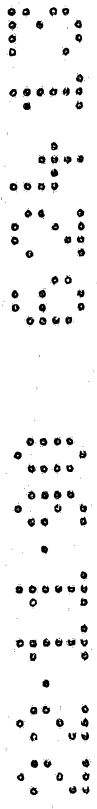

FIG. 9



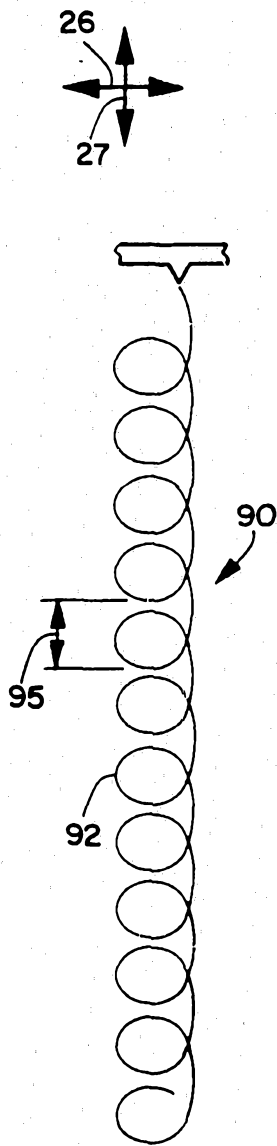

FIG. 10

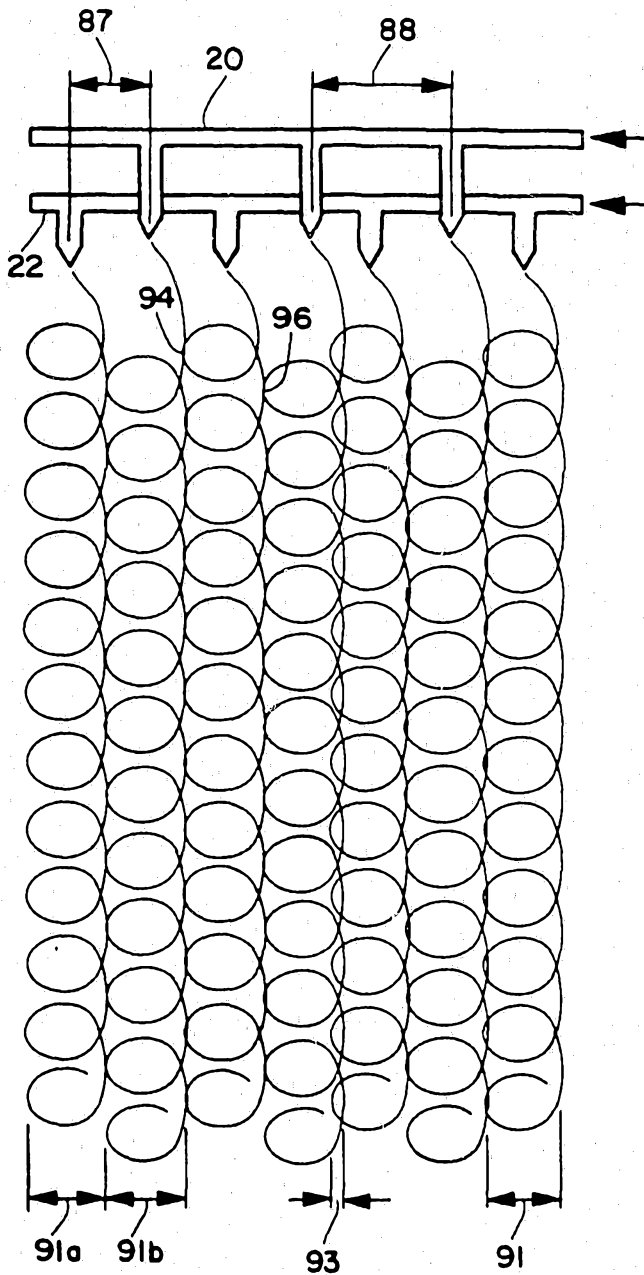

FIG. 11

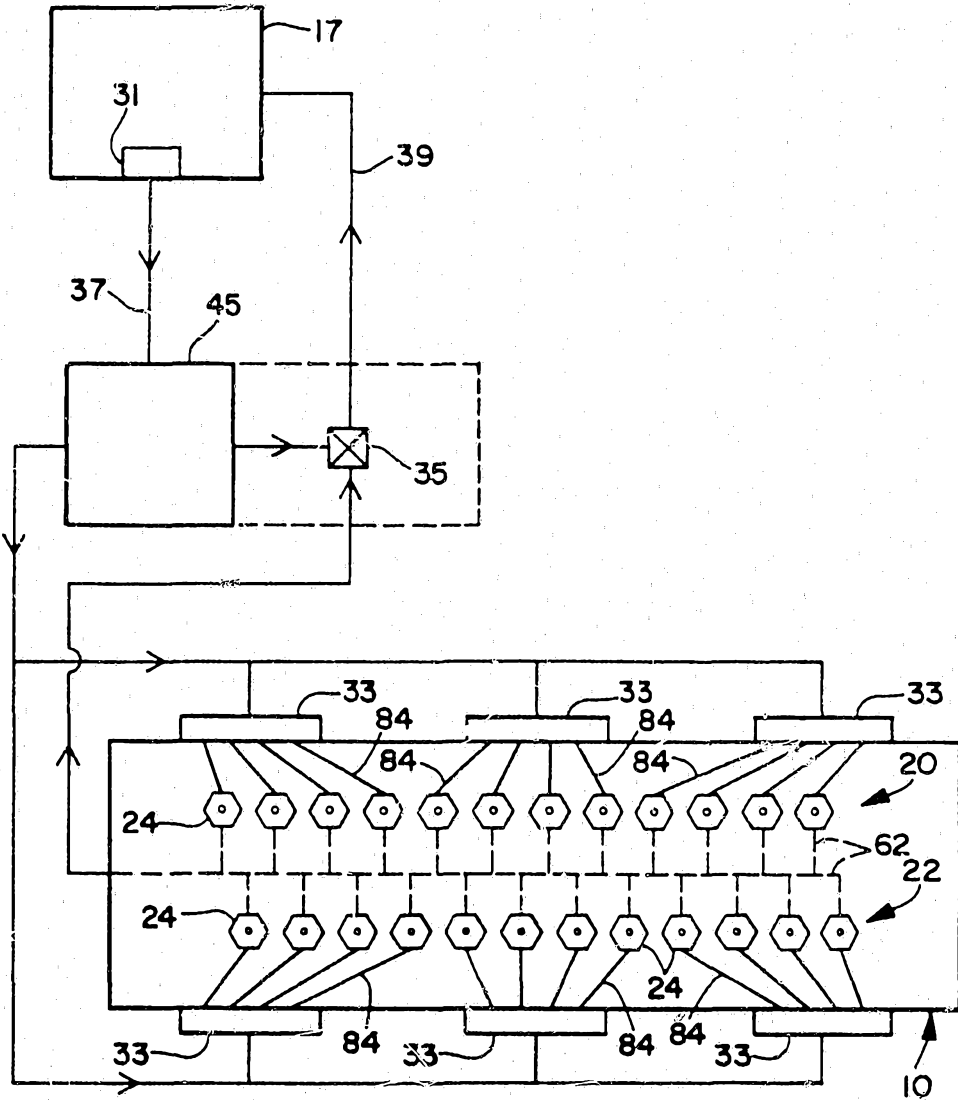

FIG. 12

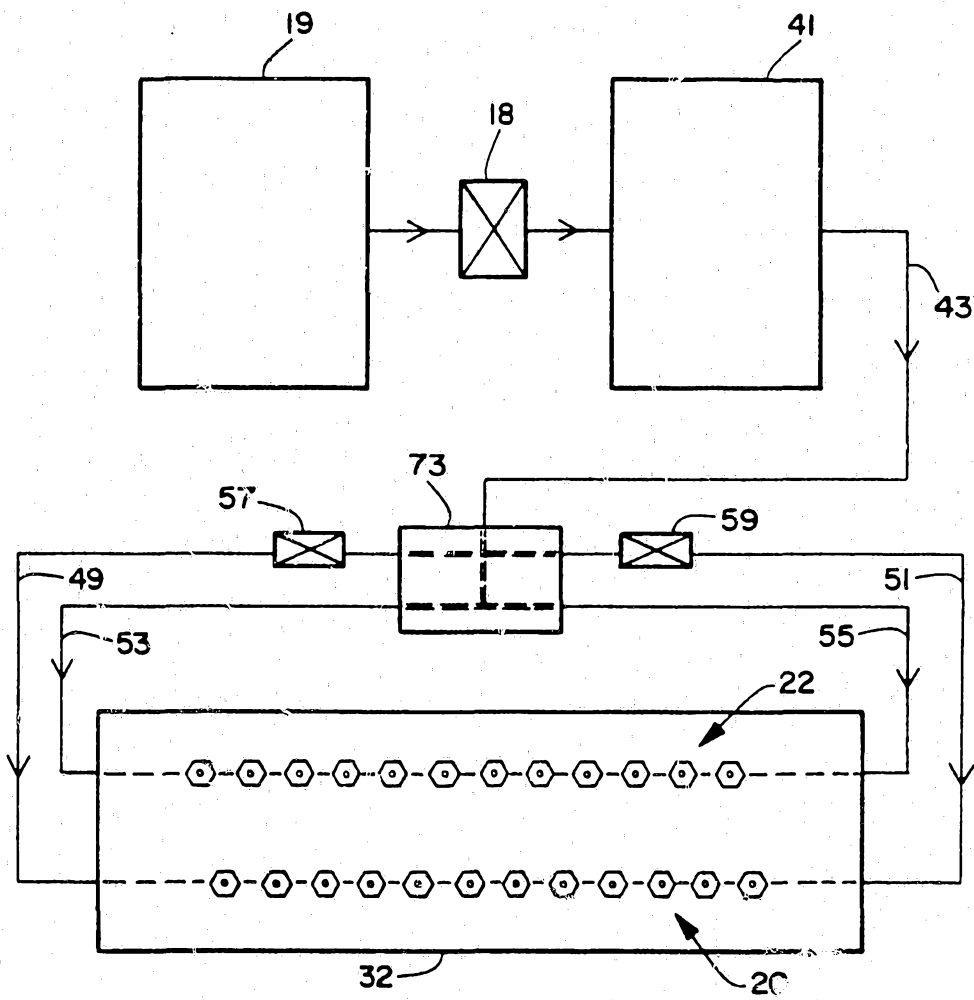

FIG. 13

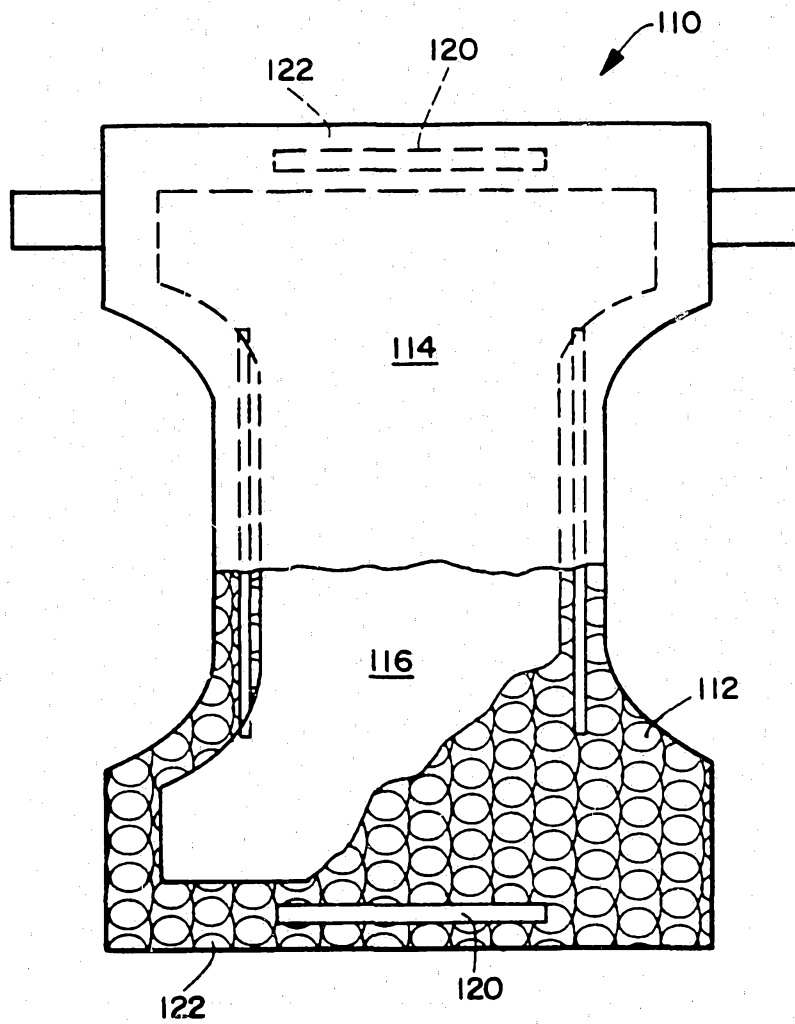
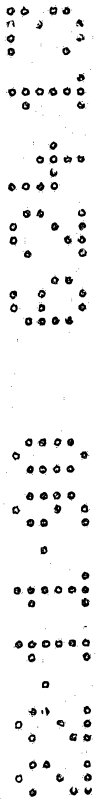

FIG. 14



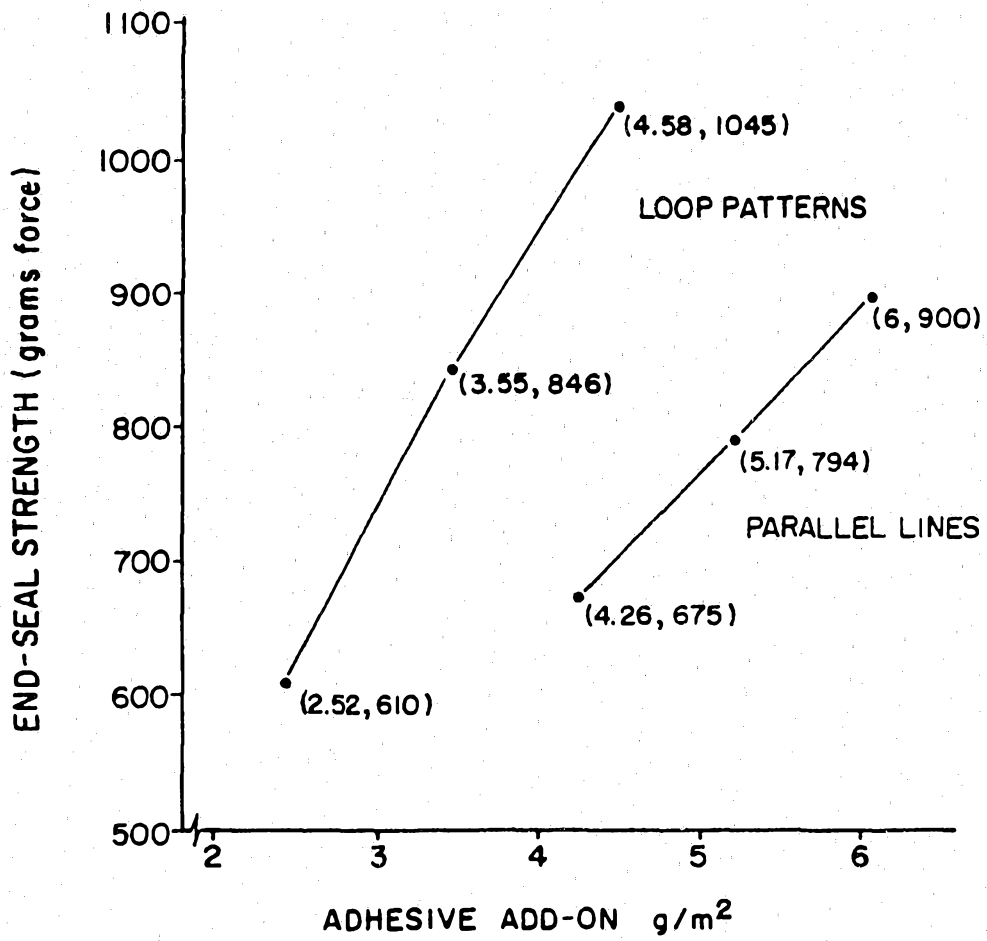

FIG. 15