

(19) World Intellectual Property Organization
International Bureau



(43) International Publication Date
30 May 2003 (30.05.2003)

PCT

(10) International Publication Number
WO 03/044663 A1

(51) International Patent Classification⁷: G06F 9/46, 17/60

HEUMUELLER, Norbert [DE/DE]; Holbeinstrasse 13, 71083 Herrenberg (DE). OESTERLE, Fritz [DE/DE]; Hauptstrasse 57, 72202 Nagold (DE).

(21) International Application Number: PCT/EP01/13756

(22) International Filing Date:
26 November 2001 (26.11.2001)

(74) Agents: JACOBY, Georg et al.; Samson & Partner, Widenmayerstrasse 5, 80538 München (DE).

(25) Filing Language: English

(26) Publication Language: English

(81) Designated States (national): CA, DE, JP, US.

(30) Priority Data:
PCT/EP01/13375
19 November 2001 (19.11.2001) EP

(84) Designated States (regional): European patent (AT, BE, CH, CY, DE, DK, ES, FI, FR, GB, GR, IE, IT, LU, MC, NL, PT, SE, TR).

(71) Applicant (for all designated States except US):
HEWLETT-PACKARD COMPANY [US/US]; 3000 Hanover Street, Palo Alto, CA 94304-1112 (US).

Published:
— with international search report

(72) Inventors; and

(75) Inventors/Applicants (for US only): BROSS, Wolfgang [DE/DE]; Kelterweg 45, 71101 Schönaich (DE).

For two-letter codes and other abbreviations, refer to the "Guidance Notes on Codes and Abbreviations" appearing at the beginning of each regular issue of the PCT Gazette.

(54) Title: METHODS, DATA RECORD, SOFTWARE INTERFACE, DATA WAREHOUSE MODULE AND SOFTWARE APPLICATION FOR EXCHANGING TRANSACTION-TAX-RELATED DATA

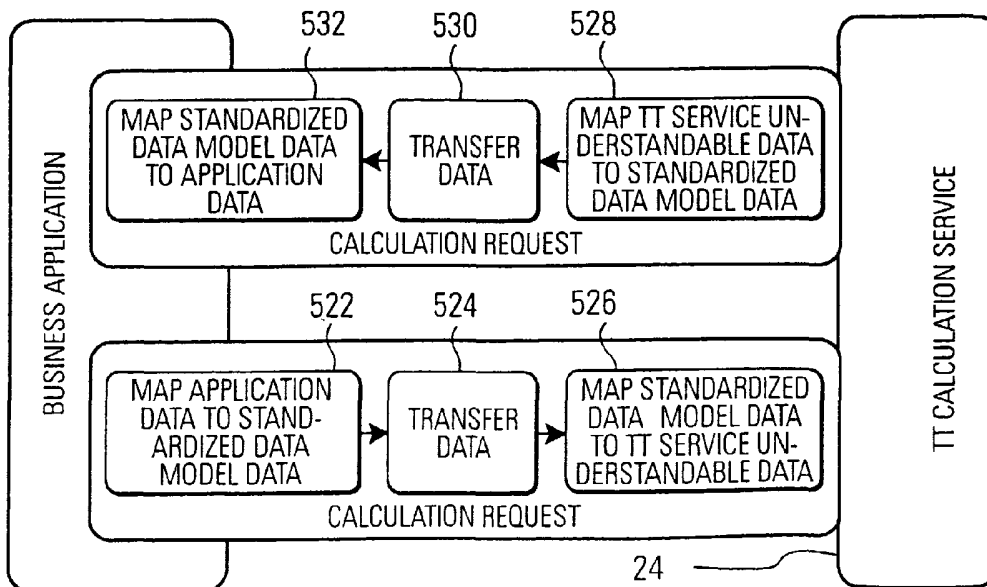

(57) Abstract: The invention is directed to a computer-based method performed in a first transaction-tax-related application. The method comprises exchanging transaction-related data with at least a second transaction-tax-related application according to a standardized transaction-tax interface data model. The invention is also directed to another computer-based method and a related data record, a related software interface, a related computer-based data warehouse module and a related software application.

WO 03/044663 A1

**METHODS, DATA RECORD, SOFTWARE INTERFACE,
DATA WAREHOUSE MODULE AND SOFTWARE APPLICATION
FOR EXCHANGING TRANSACTION-TAX-RELATED DATA**

5

FIELD OF THE INVENTION

The present invention relates generally to computerized transaction-tax processing, and more particularly to computer-based methods, a data record, a software interface, a computer-based data warehouse module and a software application for exchanging transaction-tax-related data.

10

BACKGROUND OF THE INVENTION

Besides an income tax system which imposes income-related tax liabilities on individuals and corporations, most countries have a transaction tax system. A transaction tax liability is induced by an individual commercial transaction, such as the sale of a good, the purchase of a service or the like. Typically, the transaction tax is a certain percentage of the price of the good or service. Normally, the transaction tax is collected by the vendor or service provider, who pays the accumulated transaction tax at certain time intervals (e.g. monthly) to a tax authority (for the sake of simplicity, the following description only mentions the purchase of goods, but is likewise directed to the provision of services etc.).

15

20

Throughout the world, there are mainly two different transaction tax systems: sales and use tax and value added tax (VAT). In a sales and use tax system, which is imposed in most states throughout the United States, the tax amount is derived by applying the tax rate to the retail sales price of tangible personal property or certain enumerated services. If a product is manufactured and sold in a supply chain, all transactions are non-taxable re-sales until a final retail sale to an end-user, which is taxable unless the end-user can claim an exemption from the tax. Thus, in a sales and use tax system, no tax is applied to a product until sold at retail. In a value added tax system, which is applied in many European countries, in a supply chain the transaction tax in a single individual step corresponds only to a percentage of the value added in this step, i.e. to the difference between the amount of money the vendor receives for the sold product and the taxable amount he had to spend in order to manufacture or provide the good. In such a value added tax system, the amount of transition tax accumulated over all the steps of the supply chain is independent of the number of transactions in the chain, it only depends on the price of the finished product. However,

25

30

35

normally the "added value" is not determined in individual transactions. Rather, every vendor accumulates, on the one hand, the tax received from buyers and, on the other hand, the tax he has paid to other vendors for all the transactions occurring within certain time periods (e.g. months) and pays only the difference between these two accumulated values to the tax authority. Therefore, also in a value added tax system, when looking at an individual transaction, the buyer has to pay a certain percentage of the product's price to the vendor.

Besides these principal differences between sales and use tax and value added tax, the transaction tax regulations vary from country to country, and, in the United States, even from state to state down to the level of cities and areas. For example, there are different rates in different countries and even in different states. In addition, the tax rate may depend in a country or state specific way on the seat of the vendor and/or the buyer and/or the origin and/or the destination of the good when it is shipped from the vendor to the buyer. In many countries there is a tax rate of zero for exported goods. However, in trade within the European Community transaction tax has to be paid in the country where the transaction takes place, but is then credited to the destination country in a clearing procedure carried out by the tax authorities. Also the requirements for transaction tax related bookkeeping, reporting and the form and period of tax declarations to the tax authorities generally vary from country to country.

In view of the ever-growing internationalization and globalization of enterprises and trade, there is a need for computerized systems which enable enterprises to fulfill the transaction tax requirements (preferably for different countries and states) in an efficient way.

Several products of this kind are already on the market. In one type of product, an enterprise resource planning (ERP) application (which traditionally provides for accounting, manufacturing logistics, supply-chain management, sales-force automation, customer service and support, human resources management, etc.) also enables the user to deal with the transaction taxes. For example, the ERP product R/3 by SAP provides a facility for transition tax calculation for different European countries, but not for the United States. Another type of product is a specialized application for transaction tax calculation and reporting. Examples of such an application are "TaxWare", "Sabrix", "Vertex" and "Datev".

Moreover, US patent 6,078,899 discloses a point of sale tax reporting and automatic collection system. US patent 6,298,333 discloses a computer system and method which provides a solution for a particular transaction tax related problem, namely the determination of correct use tax on moveable equipment for leasing companies.

SUMMARY OF THE INVENTION

The invention provides a computer-based method which is performed in a first transaction-tax-related application. The method comprises exchanging transaction-related data with at least a second transaction-tax-related application according to a standardized transaction-tax interface data model.

According to another aspect, the invention provides a computer-based method which is performed in a first transaction-tax-related data warehouse application. The method comprises storing transaction-related data received from at least one other transaction-tax-related application in a data warehouse according to a standardized transaction-tax data warehouse data model.

According to still another aspect, the invention provides a data record according to a standardized transaction-tax interface data model. The data record comprises transaction-related data items, for the data exchange between transaction-tax-related applications or modules.

According to yet another aspect, the invention provides a software interface for linking a first transaction-tax-related application with at least a second transaction-tax-related application. The interface is implemented such that data are exchangeable between the first and the second transaction-tax-related application according to a standardized transaction-tax interface data model.

According to yet another aspect, the invention provides a computer-based data warehouse module. The data warehouse module is configured for storing transaction-related data received from at least one other transaction-tax-related application according to a standardized transaction-tax data warehouse data model.

Finally, the invention is also directed to a transaction-tax-related software application including an interface for linking the application with at least a second transaction-tax-related application. The interface is implemented such that data are exchangeable between the first and the second transaction-tax-related application according to a standardized transaction-tax interface data model.

DESCRIPTION OF THE DRAWINGS

In the accompanying drawings:

Fig. 1 shows the main components of the transaction tax processing system;

- Fig. 2 schematically depicts the delocalization of the major components of the transaction tax processing system and its connections to each other;
- Fig. 3 illustrates the various processes performed by the transaction tax processing system;
- 5 Fig. 4 shows an example for the processes executed during a transaction tax calculation and a transaction tax logging;
- Fig. 5a shows a simplified diagram of an interface used between an external application and a transaction taxation processing service;
- Fig. 5b shows an exemplary flowchart of an external sales order module invoking a transaction taxation processing service;
- 0 Fig. 5c shows an exemplary flowchart of the interface shown in Fig. 5a;
- Fig. 5d illustrates the flowchart shown in Fig. 5c in more detail;
- Fig. 5e shows a simplified diagram of a more complex business application communicating with the transaction taxation processing services via a standardized data model;
- 5 Fig. 6 shows three tables "Inbound Data elements", "Outbound Data elements" and "Further processing elements" listing different data elements of the standardized data model according to a preferred embodiment of the invention;
- 10 Fig. 7 is a flow chart of a method carried out by a transition tax logging service;
- Fig. 8 is a diagram of the functional architecture of a transition tax filing service.
- Fig. 9 shows an exemplary flow chart of an auto-completion module according to a preferred embodiment of the invention.

25 DETAILED DESCRIPTION OF THE PREFERRED EMBODIMENTS

In Fig. 1 the main components and architectural layers of the transaction taxation system are depicted. Before proceeding further with the description, however, a few items will be discussed.

30 The term transaction tax (TT) and transaction taxation, sometimes also referred to as turnover tax, covers all kind of taxes which apply to commercial transaction processes of a company such as sales or purchases. The taxation regulations for those transactions vary from country to country and may even vary from state to state or district to district in one country. Examples for such transaction taxes are the sales and use taxes applied in the

35 United States or the value-added tax used in most European countries.

The general requirements for a transaction tax processing system are the capability of calculating the transaction tax taking into account the country-specific requirements for national and transnational transactions, the reporting and storing of the tax-related data for auditors information or company-internal use and the filing of the tax report to the appropriate tax authority.

Transactions within a company which might be subject to a transaction taxation comprise orders, financial credits, quotations and bids, incoming or outgoing invoices, returns and credits, or internal financial transactions between business units of the same company belonging to different legal or taxation systems.

According to a preferred embodiment of the invention a first transaction-tax-related application exchanges transaction-related data with at least a second transaction-tax-related application according to a standardized transaction-tax interface data model. The term transaction-tax-related application covers all applications which involve transaction taxation in the broadest sense. Those applications use an data model either for internal computations or for external communication which is referred to as application-specific data model. Thereby, the data model either used for internal computations or at least used for external communication might already be identical to the standardized transaction-tax interface data model. However, the normal situation will be that the application-specific data model differs from the standardized transaction-tax interface data model. Then, the first transaction-tax-related application preferably maps its data according to its application-specific data model to data according to the standardized transaction-tax interface model. Again, depending on the specific data model the second application is using (which might be different to or identical to the standardized transaction-tax interface model), preferably a further mapping might be required of data elements which are exchanged according to the standardized transaction-tax interface model to the data elements of the second application-specific data model. Thereby, the two different application might preferably each use a different application-specific data model whereas they communicate with each other according to the standardized transaction-tax interface data model. Naturally, if the two applications have to communicate with each other in both directions the two mapping requirements will occur in both directions. Otherwise, the two mapping requirements will occur only in one direction (for example, a particular application only invokes the other one without demanding the return of any transaction-tax related data elements or the like, e.g. the specific logging service described below may only log certain data without returning any data to the invoking application).

Thereby, the particular transaction-tax-related data items exchanged between the

different applications (as well as between different transaction taxation services and between an application and a particular transaction taxation service, see below) are grouped within a data record which is configured according to the standardized transaction-tax interface data model. The term data record covers the grouping of one or more data items either in a data record of fixed length or more preferably in a data record of flexible length. In the latter case the data record may preferably be exchanged as an argument when a transaction-tax-related application or module is invoked. More preferably, when the application (or transaction taxation service) is invoked by an HTTP (Hypertext Transfer Protocol) request, the exchanged argument is an XML (Extensible Markup Language) document forming a part of the HTTP request. The transaction-tax interface data model is preferably defined so as to provide data elements at least for a first jurisdiction and a second jurisdiction, wherein the transaction-tax interface data model has at least one first data element which used for the first jurisdiction, but is not used for the second jurisdiction, and at least one second data element which used for the second jurisdiction, but is not used for the first jurisdiction. For example, different jurisdictions of different countries might require different data items (information about the particular transaction-tax-related transaction) for calculating the transaction tax involved in that particular transaction (e.g. specifically for the United States, the reason for an exemption from transaction tax should be indicated). Another example concerns the definition of what data of a transition have to be logged. This differs from jurisdiction to jurisdiction and may depend on the company's legal type. For example, within Europe, Spain requires a more comprehensive recording of transaction data than Germany. Furthermore, different companies might have different interests in exchanging transaction-tax-related data for business-management analysis purposes. Therefore, the standardized transaction-tax interface data model might also comprise data elements which cover these particular company-specific requirements. For example, individual companies may wish to log more detailed transaction data than the minimum requirement of compliance reporting. Naturally, the standardized transaction-tax interface data model might also comprise data elements which are not yet mentioned in this specification.

According to a further preferred embodiment, the invention is directed to a computer-based method performed in a first transaction-tax-related data warehouse application. The method comprises storing transaction-related data received from at least one other transaction-tax-related application in a data warehouse according to a standardized transaction-tax data warehouse data model. Preferably, the method comprises exchanging transaction-related data stored or to be stored in the data warehouse with the other transaction-tax-related application according to the standardized transaction-tax interface

data model. Thereby, the tax-related data warehouse data model has a set of transaction-tax-related data elements and the standardized transaction-tax interface data model has a set of transaction-tax-related data elements. The set of transaction-tax-related data elements of the tax-related data warehouse data model preferably comprises, equals or is a subset of the set of transaction-tax-related data elements of standardized transaction-tax interface data model.

Usually, the transactions which are subject to transaction taxation are processed within a business application, or more particularly, within an enterprise resource planning (ERP) application such as the product R/3 by SAP. Therefore, the transaction system has to be linked to those business pr ERP applications, i.e. an appropriate interface has to be provided. Alternatively, the execution of the transaction tax processing system may be initiated via the Internet. For example, an e-business portal is provided in the Internet offering a service for transaction tax calculation. In the first case, the connection between the business application and the transaction tax processing system is realized as an Application Programming Interface (API), while in the second case the execution of the transaction tax processing system may be triggered by a client request transmitted via Internet using the HTTP protocol. In both cases, there is usually no standardized data model for the exchange of parameters with the transaction tax processing system, i.e. the transaction tax processing system needs to be able to handle various data formats and models.

The Hypertext Transfer Protocol (HTTP) is the protocol used in the preferred embodiments for communication between the different software modules of the transaction tax processing system, and in particular, between the basic services and micro services. The HTTP protocol is the standard communication protocol used in the World Wide Web (WWW), which is referred to as the Web. However, other future Web protocols or other versions of the HTTP protocol may be used in the preferred embodiments.

Various data types may be used for the exchange of information between different Web servers. In the preferred embodiments, the Extensible Markup Language (XML) is used as Web-based technology for the interface between the different software modules of the transaction tax processing system (that are possibly geographically delocalized) in order to exchange the necessary parameters. This technology allows a flexible design of data models. Each data element of the data model comprises an identifier, which can be freely defined in the so-called Document Type Definition (DTD), and a corresponding value. In contrast to HTML (Hypertext Mark-up Language), in which the data types are restricted to a given set of data types, an XML programmer can define his own data elements according to the specific needs of the application. Typically, in XML a data element is transferred via the

Web using the syntax:

```
<parameter_name id="id_name">parameter_value</parameter_name>
```

5 where the data element "parameter_name", which is sometimes referred to as "tag", is identified by its ID and carries the value "parameter_value". In this way, parameters can be passed from one software module of the transaction tax processing system to another via the Web. The data structure of XML documents can be defined by means of a Document Type Definition (DTD) or an "XML-Schema". The use of XML with an "XML-Schema" as
10 Web-based interface technology for the transaction tax processing system has the advantage of being more flexible in the definition of more complex data structures.

The term exchange of data relates to a software interface that transfers data from one application or software module to another. However, the term exchange does not imply a transfer of data in both directions and thus is not restricted thereto, but particularly comprises
15 a transfer of data only in one direction.

The term data record relates to an instance or embodiment of a data model, e.g. a data set or file transmitted via the Internet, stored on a hard disc, CD, disc, or DVD, etc.. Such a record comprises a number of data items corresponding to the data elements of a data model.

20 Now coming back to Fig. 1, which depicts the different layers of the architecture of the transaction tax processing system of the preferred embodiments. The application layer 2 comprises the software or the event which initiates the execution of the transaction tax processing system. Basically, there are two possible ways to call the transaction tax processing system. In one of these, a business application program 12, such as an
5 enterprise resource planning (ERP) application like SAP R/3 or legacy, demands transaction tax (TT) services 20 via an application programming interface (API) 16. The ERP 12 processes and stores the transaction-related data and passes the relevant parameters over the interaction layer 4, i.e. the API 16, to the process and communication layer 6 of the transaction tax processing system. In the second way, a client requests transaction taxation
0 services 20 via a Web portal 18 using the HTTP protocol. Two general embodiments of such a portal are possible. In one embodiment, the portal 18 offers a service via a Web page on which the user may specify certain transaction parameters, e.g. the purchased product, the price, the production location, the shipment location etc., and requests interactively a corresponding transaction tax calculation from the transaction tax processing system. The
5 clients does not need to know anything about the taxation rates, the jurisdiction and

regulations in the specific production and shipping countries nor to know about recent changes. The client gets back the accurate tax value and taxation rate for the specified transaction. There is also the possibility for the client to retrieve general information on taxation rates and regulations for various countries using the Web portal 18.

5 Another way to use the Web portal 18 would be by connecting the Web portal 18 automatically via a HTTP connection to a client application which might be an e-business application requiring some kind of transaction tax calculation. This client e-business application 14 then requests transaction tax calculations from the transaction tax processing system via the portal 18 automatically during its execution.

10 The main functionality of the transaction tax system is implemented via basic services 8 and micro services 10. A basic service 8 usually aggregates a number of micro services 10. However, micro services 10 can also be called as stand alone modules.

In the process and communication layer 6 specific processes for the specific client requests are defined. For each specific request a certain workflow has to be performed
15 which is controlled by the process and communication layer 6. It controls the calls of the various basic and micro services 8 and 10 and provides the communication between those services.

This layer is based on the HP (Hewlett Packard) e-speak technology which integrates the various basic and micro services. Based on a set of micro services 10 the basic services
0 8 are used in combination or stand alone within the various process steps of the transaction tax services 20.

The architecture is a true Web-based architecture using Web technology. The communication between the process and communication layer 6 and the basic services 8 as well as the micro services 10 is based on Web technology such as HTTP using XML for
5 exchanging parameters. Moreover, the same Web technology is used for communication between the basic services 8 and between the micro services 10 as well as for communication of these services 8 and 10 with each other. This standardized interface purely using Web technology allows an easy integration of new basic or micro services into the system and a complete delocalization of those basic and micro services without the need
) to introduce further network communication technology.

The transaction tax services 20 comprise and control a number of basic services 8. The content service 22 is the database containing the specific jurisdiction and rules for the various countries as well as the various tax rates and other information needed to comply with the country-specific requirements. The TT calculation service 24 provides the basic functionality of calculating the transaction tax for a specific transaction. The TT logging

service 26 decides which transactions and which content of the transactions should be logged for further reporting, that is which kind of data are needed for further analysis, auditing or reporting. The TT compliance service 28 automatically processes the logged information in a way which is suitable for a consecutive auditing. The TT filing service 30
5 finally is able to automatically fill out the appropriate tax forms and reports and file it electronically to the appropriate tax authority.

In the preferred embodiments these basic services 8 make use of many other micro services 10 such as a service 32 for managing the data base access, a micro service 34 for mapping the data between the data models and formats of the different applications, a micro
10 service 36 for determining the specific jurisdiction, a micro service 38 for retrieving the correct tax rate for a specific transaction, a micro service 40 for carrying out elementary tax related calculations, or a micro service 42 for auto-completing incomplete data sets.

Fig. 2 visualizes schematically an example for a possible geographical delocalization of the various services which are part of the TT service 20. Due to the differences in transaction
5 taxation jurisdiction in the different countries, an international company usually comprises local transaction tax processing systems which are adapted to the specific requirements of a certain country and cannot be integrated in and communicate with the other transaction tax processing systems of the company. In contrast thereto, the preferred embodiments of the transaction tax processing system allows the integration of the local transaction tax systems
0 into one system by using Web technology for the communication between the various software modules. Moreover, a standardized data model is used within all basic services and micro services facilitating the interface between two interacting services. A Web technology used in the preferred embodiments is the HTTP protocol using XML for passing the parameters from one service to the other.

5 In the example shown in Fig. 2, a client 102 located in Asia requests the transaction tax service 20 in Europe via the Internet. This TT service 20 controls the required process by calling other basic services such as the calculation service 24, the content service 22 and the filing service 30 which are located in different countries. Due to the Web-based technology of the communication between the services, the geographical proximity of the services is no
1) longer necessary. Thus, the location of the filing service is located in the country of the appropriate tax authority, the location of the calculation service is chosen according to other criteria like the cheapest hardware infrastructure or the location of a third party provider, while the various content services 104 are distributed geographically across various countries according to the location of the experts in the different countries.

In Fig. 3 the principal process of a transaction tax calculation of the preferred

embodiments is schematically depicted. Not all basic services are executed for any calculation request as the exact process varies depending on the specific calculation request 202. The definition of a specific process and the control of the order of execution of the various services and their communication with each other is performed by the process and communication layer 6 of Fig. 1.

In the preferred embodiments a calculation request 202, e.g. from an external business application, initiates the transaction tax calculation. The calculation service 24 then calculates the transaction tax on the basis of the parameters received from the calculation request 202. For this purpose, the calculation service 24 demands data from the content service 22, and in particular from its component 212 containing rules and rates and its component 210 containing the master data. The master data 210 is a centralized data base containing for example company information of a registered client, i.e. the company for which the transaction tax is calculated. Such company information for example can be the legal structure of the company which influences the type of tax calculation.

In the preferred embodiments, the content services 22 basically has the function of an interface used by tax experts for inputting, defining and maintaining the taxation rules and rates, as well as the logging and filing requirements. In particular, the components 210, 212, 214, 216 and 218 represent not only rules, data and templates, but also configuration interfaces which enable the user to input and configure these rules, data and templates.

For the parameter transfer between a calling business application and the transaction tax processing system a standardized interface data model called a tax object (T-object) is used. This standardized tax object allows a flexible link of different business applications to the transaction tax processing system. In one preferred embodiment, the same data model (T-object) is used for the internal data exchange yielding a high degree of modularization and flexibility for the integration of new modules in the existing system. In addition, in the preferred embodiments the rules requested for a specific transaction tax calculation are transmitted from the content service 22 to the calculation service 24 via an additional meta data model.

In the preferred embodiment according to Fig. 3, the calculation service 24 passes its results to the logging service 26 via a Web-based standardized interface using the T-object data model. The logging service 26 is able to retrieve logging requirements 214 from a specific section of the content service 22. This service allows the user to define what kind of transactions are to be logged and what data elements are needed as well as automatically recognizing the transactions which have to be logged. The logging requirements reflects tax jurisdictional requirements as well as special regulations of a certain client. They are defined

in the form of rules. Thus, the logging service 26 automatically determines the content which has to be logged and writes the result to the data warehouse 204. In the preferred embodiments, also data from other tax calculation engines and history data 220 can be loaded to the logging service 26.

5 Like the other communication connections between the basic services and micro services, the interface between the logging service and the data warehouse is realized in XML on a HTTP connection. While the exchange and transfer of internal data within the transaction taxation service and possible to external business applications is based on the T-object data model, the content of the data warehouse 204 is stored using a different data
10 model, a so-called data warehouse data model. Usually, the requirements for these two data models differ for various reasons, for example because of legal or auditor's requirements, internal software specific requirements or requirements of other external business applications that work together with these data models. Therefore, these two data models do not have to be necessarily identical. Either some data elements of the data warehouse data
15 model may not be part of the T-object data model, or vice versa. Additionally, the data warehouse data model may be a subset of the T-object data model, or vice versa.

The logging service 26 additionally ensures that the logged data satisfy the local authority's needs. Furthermore, the calling business applications no longer need to know which transactions have to be logged e.g. for the auditor's report or for which transactions a
20 transaction tax calculation has to be performed, as this is automatically recognized by the logging service. The logging service thus guarantees the availability of all transaction data needed for compliance reporting and tax filing also in the case that the transaction tax has not been calculated within the transaction tax processing system but by an external transaction calculation engine. If data to be logged are incomplete, the logging service can
25 use the auto-completion micro service 42 to ensure that the logged data are complete.

The data warehouse 204 represents the database for the compliance reporting and filing service 28, 30.

The compliance service 28 retrieves the report content from section 216 of the content service 22 and produces the compliance report for the auditors. If information is missing for
30 the auditor's report, the compliance service 28 can call the auto-completion micro service 42 to complete such missing information automatically in the preferred embodiments.

Similar to the compliance service 28, the filing service 30 relies on the transaction data from the data warehouse 204 to fill out the specific tax filing forms required for a certain transaction. As for the compliance reporting, the filing service 30 is able to complete missing
35 information automatically using the auto-completion micro service 42 in the preferred

embodiments. The necessary tax filing form templates 218 are defined and stored in the content service 22 and serve as a database for the filing service 30. Based on meta .data from the content service 22, the filing service 30 determines what transactions need to be filed and creates the respective information needed for the filing. The completed tax forms
5 can then be filed electronically or as hard copy with the local tax authority according to the respective governmental requirements which are as well retrieved from the content service 22.

In the preferred embodiments, an auditors service 208 is provided which retrieves via a Web-based connection technology information from the compliance report and transaction
10 data from the data warehouse 204 in order to provide information for the auditing.

The data analysis interface 206 provides an access to the central transaction database contained in the data warehouse 204 for other internal or external tools. Such tools may be data mining or other analysis tools for business relevant formation. It can also be used for tax optimization purposes for example by simulating required transaction taxes for a special
15 supply chain scenario.

In Figs. 4a and 4b, a concrete example for a transaction tax calculation according to the preferred embodiments is given. This example is a simplified representation of a specific transaction tax service. Usually, a transaction tax service comprises additional and more complex micro services which have been omitted here for the sake comprehensibility.

Assuming that a third party orders a book for the price of 40 Euros via the Amazon Web page 302 and pays the price of the book by credit card transmission. In response to this selling event, Amazon requests a transaction tax calculation 304 by a transaction taxation
20 service 20 demanding the calculation of the tax for this specific transaction using the HTTP request 34. The data related to this specific transaction are passed to the transaction taxation service 20 using XML. In this Web-based technology, a list of parameters 306 for this specific transaction of selling a book comprising for example the parameters invoice number, country, price, product and requested kind of service is transferred encoded in XML to the TT service 20 via a HTTP POST request. For each parameter a XML tag is defined containing the corresponding parameter value.

In this specific case the first micro service called by the TT service 20 is the "data mapping" 34 as shown in Fig. 4b. The micro service "data mapping" 34 implements the interface between the XML parameter list and the T-object, which is the standardized data model of the TT service 20 by converting in step 316, the Amazon parameter list into the data elements of the T-object. During this mapping it might occur that there is no one-to-one
30 mapping between both parameter sets so that some logic has to be applied in order to fill
35

those data elements of the T-object which have no direct counterpart. For example, the Amazon parameter product carrying the value "book" is mapped to a data element "product_name" and "product_category" of the T-object. The data element "product_category" may for example serve to distinguish between consumer goods or capital goods.

The following basic service "TT calculation" 24 called by the TT service 20 is composed of several micro services 36, 38, 40 and 324. First, the TT calculation 24 needs to define the appropriate jurisdiction to be applied using the corresponding micro service 36 to which the necessary parameters are passed via the T-object data model using the Web-based technology XML. The content service 22 provides the rules in the form of an additional meta data model for the determination of the specific jurisdiction to be applied. The "jurisdiction" micro service 36 in this case in which the "ship_from" parameter is "DE" (which stands for Germany) and the "product_category" is "consumer goods" determines the appropriate jurisdiction to be Germany coded as "DE" and the tax rate type to be "reduced" which are the output parameter of this specific micro service 36.

The micro-service "tax rate" 38 retrieves the specific tax rate for this case from the content service 22 using an additional meta data model in which the data are also transferred using Web-based technology and XML. Finally, the micro service "calculation" 40 performs the concrete calculation of the required tax for this transaction based on the T-object data elements "net_price" and "tax_rate". The output parameter of this micro service 40, the tax amount, is then returned to the TT service 20 using the "return" micro-service 324 again by using XML for the data transfer.

As in this special example the requested TT services from Amazon are a transaction tax calculation and a logging service, the basic service "TT logging" 26 is called next from the TT service 20. Again by using XML and handling the data over to the micro services 326 and 328 in the form of the T-object, the micro-service "log data determination" 326 determines what data have to be logged for this specific transaction. Based on the T-object element "ship_from", the micro service 326 returns in this example the net price, the absolute tax and the invoice number to be the data elements which have to be logged. Using yet another micro service "Write DB" 328, the determined logging data are written to the data warehouse 204.

Referring to Figs. 5a-e, 6 and 7, more details are provided of the specific interface linking external applications to the basic and micro services as described in the above figures as well as linking the these services with each other. As mentioned above, an external application might use a basic or a micro service, for example the TT calculation service 24, or

one basic or micro service might use another one. Proper communication between the invoking application or service and the invoked service will be ensured by the corresponding interface which has to furnish all the data required, on the one hand, for establishing a communication between the invoking service/application and the invoked service and, on the other hand, for enabling the invoked service to perform its proper function.

Reference is made to the above Amazon example given in conjunction with figures 4a and b. As already mentioned therewith, the interface (realized inter alia by the data mapping micro service 34) is used for mapping the parameters delivered in the Amazon request into the data format and model internally used by the TT calculation system 24. If numerous different external applications all having different output parameters (data elements "net price", "tax rate", etc.) used the basic and micro services, a corresponding number of different data mapping micro services would have to be invoked by the TT calculation service 24 for proper communication with these applications. This, however would imply a considerable data mapping effort at the TT calculation service side.

Hence, according to a preferred embodiment of the invention, the data model used for communication between external applications and basic and micro services as well as between different basic and micro services (it should be noted that some basic or micro services may be externally provided and might possibly use a different data model than the internally provided basic and micro services) is standardized. It will hereinafter be referred to as tax object. The use of a standardized data model advantageously eliminates the need for complicated interface structures since now each interface only needs to implement a data mapping of the internally used data model to the standardized data model and vice versa. In other words, each service only receives data implemented in the standardized data model object irrespective of the application sending these data and, in turn, delivers only data in the standardized data model to any other application/service.

Returning to the specific model depicted in figure 1, any external application invoking sequentially or in parallel several of the basic or micro services, for example first of all the TT calculation service 24, then the TT logging service 26 and finally the TT filing service 30, needs only one mapping module at the application side for mapping its application-specific data elements to the respective data elements in the standardized data model irrespective of the specific invoked basic service. Moreover, if the respective invoked service internally uses the standardized data model no further mapping will be required at the service side. In practice, however, it might be further necessary to transmit some additional data not yet provided in the standardized data model, for example for controlling the communication between the invoking and the invoked application/service. This will often be the case for the

different basic and micro services described with regard to figures 1 to 4 when communicating with each other. In view of the numerous communications in the overall set of links between external applications and internal services a data model comprising data in the standardized data model as well as individual data will be preferred wherein the individual data are necessary for the particular communication between a particular pair of applications/services. These individual data might consequently require an individual mapping at the interfaces on the application and the service side. An overall standardized data model also covering all these individual data elements seems to be less preferred since, depending on the way data is exchanged, the transfer of a large amount of data may be required.

In a preferred embodiment, the interface at the service side might comprise a mapping module 34, as shown in Fig. 4b, realized in the form of a micro-service within the structure of the TT services 20. This mapping module 34 will be invoked by the process and communication layer 6 of the TT services 20 upon receipt of a tax calculation request (or any other request, calling one of the basic or micro-services) wherein such an external request comprises the application-specific data elements. The mapping module then serves to convert the application-specific data elements into the standardized data model which will be used by most or all of the basic or micro services invoked by the process and communication layer 6 in connection with the particular external request, for example the external tax calculation request. As described with regard to the TT services 22 to 40 as shown in figure 1 most of the basic services invoke a couple of micro services. Hence, the communication between these micro services and the invoking basic service uses the standardized data model advantageously omitting further mapping procedures.

In another preferred embodiment, the mapping of the application-specific data elements into the standardized data model might alternatively take place at the external application interface advantageously pre-empting the need to invoke the data mapping 34 at the TT services side. Naturally, even in the latter case such a data mapping 34 at the TT services side will be required if any one of the micro or basic services internally uses a different data model. In this case, the data mapping 34 comprises a mapping from the standardized data model into the internally used data model and vice versa when invoking this particular micro or basic service.

A preferred embodiment for an interface structure will now be described with respect to Figs. 5a-e wherein one part of the interface is implemented at the TT services side 20 and the other part is implemented in the form of an external interface at the application side.

Fig. 5a shows a simplified schematic diagram of such an interface used between an

external application and the TT services 20. In Fig. 5a, reference number 500 designates an external business application a part of which is described in Fig. 5b. In the particular example shown in Fig. 5b the business application comprises a sales order module performing inter alia the steps shown in this figure. In a first step 502, a sales order is created, which is followed by a second step 504 in which item data (material number, quantity, etc.) are added. In a subsequent step 506, a pricing for the item is performed which requires the addition of the specific tax calculated for this item. In order to complete the tax calculation, in a subsequent step 508, the TT calculation service 24 is invoked via an HTTP request delivering the specific data elements necessary for the tax calculation. The TT calculation service 24 calculates the tax and returns the calculated value to the business application which transfers the calculated tax back to the pricing in a step 510.

As can be seen from Fig. 5a, the communication between the business application 500 and the TT calculation service 24 is performed via a transaction tax standardized interface 512 using a standardized data model, namely the tax object (see below). The interface 512 requires a data mapping 514 and a processing/communication 516 on the business application side and a data mapping 518 and processing/communication 520 at the TT calculation service side (for example performed inter alia by the data mapping micro service 34).

The interface processing 516 and 520 on either side provides error handling (checking for erroneously transmitted or missing data, interface errors, tax engine errors, etc.), a specific calculation request handling (a credit/return, reference to former invoice, etc.), transaction type (sale, purchase), exemption processing, audit file processing, number of records, exemption certificate determination, document summary, etc.) and a special processing (line item/end of invoice, etc.). The particular data mappings 514 and 518 will be discussed in detail with reference to Fig. 6 below.

Fig. 5c shows a simplified diagram illustrating steps performed by the interface 512 between the business application 500 and the TT calculation service 24. Invoking the TT calculation service 24 in step 508 in Fig. 5b comprises mapping of data according to the application-specific data model to data of the standardized data model in step 522, transferring the mapped data in step 524 and mapping the transferred data to service understandable data in step 526, for example, to the particular program code used by the TT calculation service 24. On the other hand, returning the calculation result of the TT calculation service 24 to the application 500 comprises mapping of the service understandable data to data according to the standardized data model in step 528, transferring the mapped data via the Internet in step 530 and mapping the transferred data

into the application data, i.e. the particular parameters used in step 510 of Fig. 5b, in step 532. Besides, the interface architecture is configured to deal with single data items as well as with a set of data items grouped to a data record.

Reference is now made to Fig. 5d illustrating the steps shown in Fig. 5c in more detail. Similar reference numbers in Figs. 5c and 5d designate similar method steps. As can be seen from Fig. 5d, the mapping step 522 performed at the business application side comprises a step 532 for reading an output mapping definition, a step 534 for deriving source information based on the read mapping definition, a step 536 of mapping the source information to the tax object and a step 538 for configuring the mapping definition and delivering the same to step 532 upon request. The data transfer step 524 comprises a step 540 for calling the TT calculation service 24 (performed for example via the HTTP protocol) and a step 542 for retrieving the tax object and the calculation request. The mapping step 526 comprises reading an input mapping definition from a mapping configuration routine 546, and a step 548 of mapping the tax object to the target information. The target information is then delivered to the TT calculation service 24 which returns the calculated tax rate. The returned tax rate is mapped to the target object in step 528. Thereby, step 528 comprises the step 550 of reading an output mapping definition which is again delivered from the mapping configuration routine 546 and a step 552 of mapping the target information (the calculated tax rate received from the TT calculation service 24) to the tax object. The tax object is then transferred in step 530 to the business application 500 which comprises a step 554 of sending the tax object as a calculation result on the TT services side 20 and a step 556 of retrieving the tax object and the calculation result on the business application side. Besides, the mapping steps 526 and 528 may be omitted if the TT calculation service 24 uses the standardized data model as internal data model. In this case a simple conversion of the tax object in form of a Web-transferable document (specific object in an HTTP request, etc.) into machine-readable program code will be required. However, in this case it might be further required to merely convert technical data elements used for the technical implementation of the interface which can be done in steps 540, 542, 554 and 556. These technical data elements preferably do not form part of the tax object. The retrieved tax object is transmitted to the mapping step 532 which comprises a step 558 of reading an input mapping definition delivered from the mapping configuration routine 538, a step 560 of mapping the tax object to the source information and a step 562 of deriving a source information based on the mapping definition. The result of step 562, namely parameters or a set of parameters understandable by the business application 500 is then transferred to step 510 shown in Fig. 5b and used for further calculations within the business application 500.

In steps 538 and 546, the set of mapping rules might be preferably implemented in the form of two tables, the first one containing header data and the second one containing item data. A rule consists of a header table record and n item table records, wherein n is equal to 1 or an integer greater than one. The two tables might be accessible by a transaction in order to externally configure the rules within these tables (rule definitions might be created via a transaction table maintenance). In other words, the rules are configurable by external access. A rule definition will be entered into the rule header and the rule item table in form of records having the structure as shown in the following diagram:

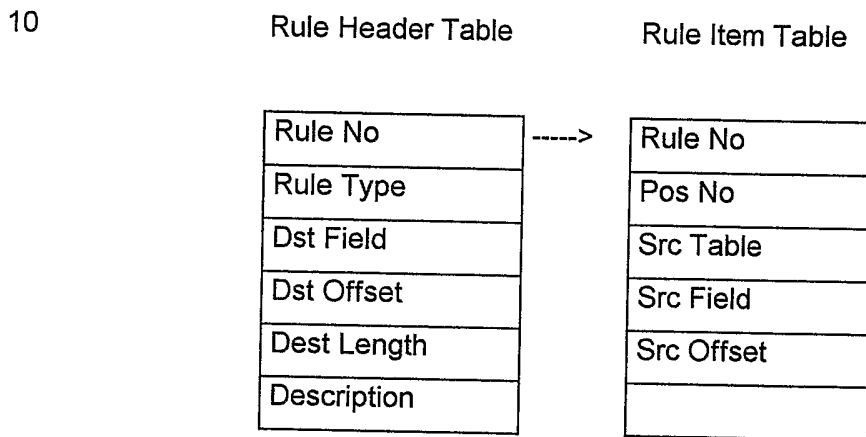

wherein corresponding records in the rule header and the rule item table which establish a specific rule (as indicated by the arrow in the above table) are defined via identical entries in the "Rule No" field (several records in the rule item table might have the same rule number meaning that they form a complex rule). Hereby, the "Rule Type" field indicates the particular mapping type selected from the group consisting of static mapping (S), constant mapping (C) and dynamic value lookup (D) (see below). The "Dst Field" field designates the particular destination field. The "Dst Offset" field designates an offset of the destination field, the "Dst length" field a length of the destination field and the "Description" field enables the user to enter a particular comment to the underlying rule (only optionally provided). The "Pos No" field in the rule item table is a counter for the record number in the rule item table belonging to a single rule (a record in the rule header table having a specific rule number might correspond to several records in the rule item table having the same rule number). The "Src Table" and "Src Field" fields define a source table and a source field, respectively. The "Src Offset" field designates an offset of the source field.

A first preferred mapping type, the so called static mapping, comprises assigning the value of a certain source field to a certain destination field.

A further preferred mapping type, the so called constant mapping, comprises assigning a fixed value to a certain field in the destination structure.

Another preferred mapping type for complex mapping situations, the so called dynamic mapping, comprises assigning the mapping result of a mapping function to the destination field wherein the mapping function is based on rules and is given in the form:

```
destination_field = mapping_function( source_field_1, source_field_2,...)
```

Thereby, the values of the source fields "source_field1", "source_field2", etc. are the input parameters of a specific mapping function which outputs its mapping result to the field "destination_field".

In a preferred embodiment of the present invention, the mapping function is defined via a lookup table (together with the two above mentioned tables) having as its contents the source information of the different source fields and the corresponding mapping result, for each rule. More particularly, the lookup table preferably contains generic keys for each rule. The generic keys are formed by concatenating the contents of all source fields of a rule. For each rule, the lookup table contains an entry for a generic key and a corresponding mapping result. Hence, the mapping result for the generated generic key is read from the lookup table and moved to the destination field of the rule (as indicated by the corresponding record in the header data table, cp. above).

It will be appreciated that the static and constant mapping via the specific tables as described above and the dynamic mapping via the specific lookup table as described above is only one possibility for implementing mapping rules within the mapping configuration routines 538 and 546. Another very intuitive implementation for these routines consists of establishing rules via a user definable rule definition interpreter. Those rules may be defined in a particular rule based language (for example Jnana™, Lisp, Prolog, etc.) which provides for a very intuitive user/machine-interface. Entering such rules into the mapping configuration routines 528 and 546 demands merely knowledge about the underlying business model but not of the underlying program structure. Thus, these rules might be entered by a user with business skills only. The rule based language generally comprises an interface allowing access to external access data (defined as source fields within the rules) and allowing deliverance of external output data (defined as destination fields). The rules are entered in terms of the rule based language wherein the user with business skills needs only to know the sets of access and output data for entering the rules connecting a set of output data with a set of access data.

Fig. 5e shows a simplified diagram of a more complex business application 500 divided into different application routines which all may benefit of the TT services 20 as mentioned above. A first routine 570 deals with the product generation requiring the exchange of data with the data warehouse 204. This data exchange is performed via the standardized data model, namely the tax object. Further routines of the business application 500 might comprise an order generation 572, an order management 574, a planning 576, a procurement 578, a production 580 and a logistics routine 582 which all invoke the TT calculation service via the tax object (the direction(s) of the arrows between the business application modules and the the TT calculation service 24 indicates the data flow direction (inbound and outbound data elements, cp. below). All mentioned modules 570-584 might further exchange data with the data warehouse 204 via module-specific or data warehouse specific data models for a transaction taxation master data maintenance, as shown with reference number 590. The same applies for the data exchange between the TT calculation service 24 and the data warehouse 204. The overall business organization further contains a delivering module 582 and a financial management and reporting 584, wherein the latter one invokes the TT compliance service 28 via the tax object. The TT compliance service retrieves information from the data warehouse 204 via a specific data model. The same applies for the data mining 206.

According to a preferred embodiment of the invention, the structure of the tax object transferred between the business application and the TT services 20, between external business applications or between different basic and micro services will now be described with respect to Fig. 6. Fig. 6 shows three tables "Inbound Elements", "Outbound Elements" and "Further processing elements" dividing the different data elements of the tax object into inbound elements (data elements which will be passed to a TT service 20 from an external application or an internal TT service 20), outbound elements (data elements which are created, calculated or changed by the TT calculation service 24) and further processing elements, respectively (data elements which drive special processing either within the invoking application or within the TT service 20). In all three tables shown in Fig. 6 the data elements are listed in a sequential order as indicated in the first column "Field No." (in practice, the tax object might not necessarily be sent with the data elements in the given order but may be sent as a XML document having the corresponding data element identifier). Each line of the tables contains a different data element (identified in the second column "Data element"), wherein some data elements are divided into different sub data elements (identified in the third column "Sub Data element"), for example in line 4 of the table inbound elements, the ship-from address data element is divided into the street, territory, province,

country, city, postal code, state and country sub data elements.

Besides, the tax object is defined so as to provide data elements for at least two different jurisdictions. It has at least one data element which is used for one jurisdiction, but not for the other jurisdiction (for example, in line 32 of the table outbound elements the data element "Tax certificate applied" is US-specific), and it has at least one other data element
5 which is used for the other jurisdiction, but not for the first one (for example, in line 92 of the table inbound elements the data element "Destination code" is EU-specific).

Furthermore, the tables describe in its fourth column "Type" the specific data element type for each data element, for example in line 48 the postal code is labeled as a character
10 with five elements. The tables further show a more detailed description for each data element in their fifth columns "Description". The table "Inbound Data elements" further indicates in its sixth column "Required" whether the corresponding data element is must be transmitted within the tax object when invoking the TT calculation service 24 (there may be different required data elements when invoking other TT services 20, i.e. the column
15 "Required" deals only with the particular invocation of the TT calculation service 24). In particular, the data elements "company-ID", "ship-from address" and "destination/ship-to address" are the only three data elements which must be transmitted within a tax object to the TT calculation service 24. All other data elements might be supplemented according to the special request of a TT service 22 to 40. For example, when the TT calculation service
20 24 is invoked by the business application 500 as shown in Fig. 5b, besides the three required data elements, the data element "line item amount" (in line 120 of the table inbound elements) is transmitted within the tax object. Naturally, the transmitted tax object only contains the values of the different data elements, possibly supplemented with the corresponding data element identifier. When implementing the tax object in the form of an
25 XML document further data elements, not yet shown in Fig. 6, can be easily defined for any future enhancement requirements (further processing logic, etc.).

For example, the tax amount calculated by the TT calculation service 24 is returned within the tax object as the data element "Calculated tax amount" (field number 48 of the table "Outbound Data elements") to the business application 500. Implementing the tax
30 object in a flexible data model, for example XML, eliminates the need to transmit all data elements (inbound, outbound and further processing elements) when transmitting a particular tax object (which would involve the transmission of roughly 230 data elements each time, most of which are deactivated). Therefore a particular transmitted data record may contain only data items complying with one jurisdiction, although the interface data model comprises
35 data elements complying with various different jurisdictions, e.g. in different countries.

Hereinafter, a simplified example is given for an external business application invoking a TT calculation service 24 for tax calculation and will be described in more detail on the basis of the required mapping of the application specific data model to the standardized tax object.

5 For example, the external SAP business application invokes in step 508 of Fig. 5d the TT calculation services 24 which triggers an application subroutine creating a SAP export data record COM_TAX commonly used by the SAP business application for exporting data. The export data record might in this example consist of the data fields "prices_netprice" and "customer_ship from address". Hereby, the indicator preceding the "_" indicates the source
 10 address (for example a table name, etc.) whereas the indicator succeeding the "_" indicates the field name. It is assumed that when creating this export data record the data fields "net price" and "ship from address" are filled with the particular data values "500" and "DE", respectively. The export data record COM_TAX is transmitted to the mapping routine 522 of the interface module at the SAP business application side.

15 The mapping routine 522 requests in its step 522 the mapping configuration routine 538 for delivery of the set of configurable mapping rules which correspond to this particular external tax calculation invocation. In the specific example, the mapping rules might consist of a static, a constant and a dynamic mapping.

The static mapping might concern the mapping of the field "netprice" in the table
 20 "prices" to the field "line item amount" (as indicated in figure 7 in line 120) of the tax object. The following rule creates such a mapping:

Rule Header Table

Rule No: 0001
Rule Type: S
Dst Field: line item amount
Dst Offset: 0
Dest Length: 10
Description

Rule Item Table

Rule No: 0001
Pos No: 01
Src Table: prices
Src Field: netprice
Src Offset: 0



25

The rule No. 1 contains the entry "prices" in the source table field and the entry "netprice" in the source field (both mentioned entries are entered into the rule item table) and the entry "line item amount" in the destination field (this entry is entered into the rule header table). Furthermore, the value of the field "Pos No" of the rule item table is set to 1 since

there is a static mapping (cp. entry "S" in "Rule Type" field of the rule header table) of the value of exactly one field in the source structure to exactly one field of the destination structure.

Similarly, a rule for a static mapping of the "customer_ship from address" to the destination field "ship-from address_country" (as indicated in figure 7 in line 8 of the tax object, wherein the mentioned field consists of a data element field "ship-from address" and a sub data element field "country" both together forming the destination field) has the following form:

10

Rule Header Table

Rule Item Table

Rule No: 0002
Rule Type: S
Dst Field: ship-from address_country
Dst Offset: 0
Dest Length: 2
Description

----->

Rule No: 0002
Pos No: 01
Src Table: customer
Src Field: ship from address
Src Offset: 0

As an example for a constant mapping, the tax object might comprise a data field "version no" (provided in the reserved space table) which identifies the particular program version of the calling SAP business application. The corresponding constant rule has the following structure:

20

Rule Header Table

Rule Item Table

Rule No: 0003
Rule Type: C
Dst Field: version no
Dst Offset: 0
Dest Length: 5
Description

----->

Rule No: 0003
Pos No: 01
Src Table:
Src Field: v4.01.A
Src Offset: 0

As a result, the fixed value "v4.01.A" will be assigned to the destination field "version no".

As an example for the dynamic mapping (which allows processing of the information from several source fields and mapping of the result to a particular destination field) the destination field "currency" of the tax object (cp. figure 7, line 84) will be considered. For example, in the country "Germany" the currency will be changed from "DM" to "Euro" at the end of year 2001 which means that the year of the transaction date is an indicator for the currency, i.e. the years ..., "2000", "2001" indicate the currency "DM" whereas the years "2002", "2003",... indicate the currency "Euro" for Germany. A corresponding dynamic mapping will have the following form:

Rule Header Table

Rule No: 0004
Rule Type: D
Dst Field: currency
Dst Offset: 0
Dest Length: 4
Description

Rule Item Table

Rule No: 0004
Pos No: 01
Src Table: customer
Src Field: ship from address
Src Offset: 0

Rule No: 0004
Pos No: 02
Src Table: date
Src Field: year
Src Offset: 0

15

This rule contains one record in the rule header table and two records in the rule item table as indicated by the "Pos No" field counting the number of records of a single rule in the rule item table. The information is taken from the source tables "customer" and "date" and the respective fields "ship from address" and "year" whereas the mapping result is written into the destination field "currency". The table "date" with its source field "year" might not be part of the export data record COM_TAX and should therefore be directly accessed from SAP internal tables which are not transmitted to the mapping routine 522.

20

In the particular example given above, the lookup table will have the following entries:

Lookup Table

Rule	Key	Result
....
0004	DE2000	DM
0004	DE2001	DM
0004	DE2002	Euro
0004	DE2003	Euro
....

5 Thus, when reading the values "DE" and "2001" from the source fields "ship from address" and "year" in step 534, concatenating these values will give the result "DE2001". This result forms a generic key such as the ones listed in the lookup table in the middle column. The corresponding mapping result "DM" is then read from the right column in the lookup table and moved to the destination field "currency" in step 536.

10 A configuration of the rule might be performed by external access to the lookup table and changes to its content, for example by accessing the lookup table responsive to the external tax calculation call and by changing its line "0004|DE2002|Euro" into "0004|DE2002|DM" (if the introduction of the currency "Euro" is postponed to year "2003" in Germany). This configuration may be accessible via a transaction call "Change mapping configuration SAP-Tax Object" giving access to the mapping configuration routine 538 and
 15 allowing changing of the corresponding rules. The advantage of user configurable mapping rules over hard coded mapping rules lies in the easy handling of changes to these rules (as can be seen from the above example) since the user only has to deal with these rules on a business level rather than on the machine level which requires skilled programming
 20 knowledge.

When defining the rules via the mentioned rule interpreter, the user enters a list of rules which define the data mapping from the SAP export data model COM_TAX into the data model of the tax object. As the tax object has the specific well-defined data elements " ship-from address_country", "version no" and "currency" the user has for example to deal with the
 25 following questions concerning these data elements:

- which SAP-field contains the information of the particular data element?
- is this SAP-field exported via the export data record COM_TAX?

- otherwise, can it be found in a SAP database table (if yes, in which table)?
- otherwise, what can be done to get this information in the system (for example, can it be derived from other SAP fields). In this case, the user has to define a number of more complex rules (for example, similar to IF...THEN....constructs and the like) to evaluate this information from other SAP fields.

5

In step 536, the destination data are brought in the particular data model language used for the transmission, for example XML. A corresponding XML document for the above example will have the following form (and might be transmitted in the body of an HTTP request):

10

```
<tax object>
  <inbound elements>
    <ship from address>
      <country>DE</country>
      <line item amount>500</line item amount>
      <currency>DM</currency>
    </inbound elements>
    <reserved space>
      <version no>v4.01.A</version no>
    </reserved space>
  </tax object>
```

15

20

25

In the above presentation control commands including possible error messages and the like are omitted which, however, may be part of the tax object. These commands may be entered into the tax object and removed from the same in steps 540 and 542, respectively, where they are used for transmission control.

30

When the TT calculation service 24 has the same data model as the tax object, the mapping routine 526 in figure 5d is reduced to a simple conversion of the XML document into a program understandable code (e.g., C++ code, etc.).

35

The advantages of the standardized data model used for the transmission of business and control data elements can be easily seen from the above description of the simplified example. A programmer working with a particular program module (either the external SAP business application or the TT calculation service 24) needs only to know the particular data

model of the program module he is working with and the data model of the standardized tax object but not the data model of the other program module. Consequently, he only needs to configure mapping rules (e.g. in steps 538 or 544) for mapping the data model of his program module to the one of the standardized tax object, and vice versa.

5 The TT logging service 26 shown in Figs. 1 and 3 will now be described in more detail. "Logging" means storing of transaction-tax-related transaction data. In most jurisdictions it is required that transaction data of tax-relevant transactions are recorded on transaction-by-transaction basis. Furthermore, companies have often their own interests in recording tax-relevant transaction data for business-management analysis purposes. Recording of
10 transaction data in a way which fulfills at least the minimum requirements of the tax laws in a certain jurisdiction enables a "transaction tax compliance reporting" (for that particular jurisdiction). The logged transactions form the basis for the tax filing, i.e. the calculation of the amount of transaction tax to be paid to the tax authorities and preparation of the corresponding tax declaration which has to be made in certain time intervals, for example
15 monthly. The logged transaction data are also used for transaction-tax review by official and internal auditors. Logged transactions may be trade invoices, general ledger (G/L) bookings (i.e. bookings in a company's general account book which appear when a payment has been received or made), etc.. In most jurisdictions, it is not required to log every transaction-tax-related transaction for compliance reporting. For example, transactions with provisional
20 character, such as offers or orders, need not be logged. The requirements as to which transactions have to be logged differ from jurisdiction to jurisdiction. They may even be different for different types of legal entities, for example corporations and partnerships. The definition of which transactions have to be logged may also be company-dependent since individual companies may wish to carry out a more comprehensive reporting than the
25 minimum-required compliance reporting.

Also the definition of what data of a transition have to be logged differs from jurisdiction to jurisdiction and may depend on the company's legal type. For example, within Europe, Spain requires a more comprehensive recording of transaction data than Germany. Again, individual companies may wish to log more detailed transaction data than the minimum
30 requirement of compliance reporting, so that the definition of what transaction data have to be logged may be company-dependent. The TT logging service 26 of Figs. 1 and 3 enables such a variable kind of logging.

The TT logging service 26 is a software component which can be invoked independently of other basic services 8, in particular independently of the TT calculation
35 service 24. This enables the use of different transaction tax calculation applications to the TT

calculation service 24 (for example, the use of external tax calculation provided by external service providers) without affecting the TT logging service 26. Furthermore, it enables stored data, such as stored history or legacy data 220 generated by non-integrated tax calculation engines, to be loaded directly to the TT logging service 26, as is indicated by an arrow in Fig.

5 3. In contrast, in the known transition tax program products, the recording of transactions is intimately linked with the tax calculation, so that only those transactions which have previously been passed through for the program's tax calculation are recorded.

The TT logging service 26 is invoked by an HTTP request from the process and communication layer 6 together with an argument comprising transaction-related data, for example in the form of an XML document forming the body of the HTTP request. The transaction-related data elements of the argument are preferably identical with the transaction tax object or are a subset of the transaction tax object described in connection with Fig. 6.

The rules defining which transactions and what transaction data are to be logged (called "log rules") are contained in the content service 22 in a form configurable by the user in a filing rules and templates configuration interface 218. The content service 22 is shared between different basic services 8, and therefore also contains rules and "meta data" for the other basic services 8, as shown in Fig. 3. In other embodiments (not shown), the content service is modular, the TT logging service then has a special log rule management service.

15 20 When the TT logging service 26 is invoked it fetches all, or a subset of, the log rules and evaluates them with the data of the transaction for which it has been invoked. In the case in which only a subset is fetched, it is composed of those log rules which may be relevant for the decision whether the transaction has to be logged and what transaction data are to be logged. For example, in a transaction in which a good is shipped from Germany by a German seller, the subset of rules fetched from the content service 22 comprises all the log rules which relate to Germany.

The log definition is not hard-coded in the content service or the logging service application. Rather, the log rules can be input and modified by the user in a log rule configuration interface 214 which is part of the content service 22. The log rules can be entered by the user online in the form of a script language. After having fetched the script language log rules, the TT logging service 26 interprets them and processes the log request accordingly.

The TT logging service 26 has an auto-recognition functionality: it can decide itself whether a transaction is to be logged, and, if applicable, what data of the transaction are to be logged, by evaluating the log rules with data of the present transaction received together

with the HTTP request which has invoked the TT logging service 26. Therefore, no previously invoked component (for example, the calculation service 22) needs to decide whether the present transaction is to be logged or not (if such a decision were taken by a previous component, the logging service could only be invoked when logging is required). Rather, since the TT logging service 26 takes this decision itself, it can be invoked for every event (i.e. for every transaction) without any parameter representing a log requirement. As a consequence, any application generating transactions can be used together with the TT logging service 26 without having to take care itself whether transactions have to be logged. This auto-recognition functionality enhances the modularity of the whole transition tax application since it enables the log requirement information to be concentrated in the content service 22 and the logging service 26 and the other services can be kept free of it.

The following table illustrates in a simplified way the log requirement rules for two different jurisdictions ("countries") and three different transaction types:

	<u>country X</u>	<u>country Y</u>
<u>order</u>	no logging required	no logging required
<u>invoice</u>	logging required	logging required
<u>payment</u>	no logging required	logging required

15

When the TT logging service 26 is invoked with the data of a transaction as parameters, it evaluates the log requirement rules with the parameter data. If, in the above-mentioned example, the country of a transaction is "X", and the transaction type is "order" or "payment", no logging is performed. If, in contrast, the country is "X" and the transaction type is "invoice", logging is performed, based on further rules which define what transaction data have to be logged for the present transaction. For example, for a certain country with low logging requirements, only the invoice number, net price and tax of the transaction are logged. In a country with more comprehensive logging requirements, further transaction data, such as the buyer registration number, the product description, the tax rate applied, etc. are logged. If the country of origin is "Y" logging is also performed for the transaction type "payment", in the above example.

20

Fig. 7 is an exemplary flow chart of a method carried out by the TT logging service 26 of Figs. 1 and 3. In step 602, the TT logging service component 26 is invoked, for example by receiving an HTTP request with transaction data as argument, which may be in the form of an XML document included in the body of the HTTP request. However, any other suitable invocation mechanism may be used. In step 604, the log rules which may be relevant for the

30

present transaction are fetched from the content service 22. In step 606, the log rules are evaluated for the present transaction data and it is ascertained whether logging is required. If the answer is negative, in step 608, a flag is set in the transaction data to be output as an XML parameter list indicating "Transaction has not been logged". In step 610, the call to the TT logging service 26 is returned by sending an HTTP response with the XML parameter list to the origin of the original HTTP request. However, if the answer in step 606 is positive, the log rules are evaluated in step 612 as to what data have to be logged, using the input transaction data. In step 614, the data set to be logged is prepared (e.g. a data set consisting of invoice number, net price and tax). In step 616, the prepared data set is stored in the data warehouse by sending a corresponding request together with the data set to the data warehouse component 204. In step 618, a flag is added to the transaction data to be output as an XML parameter list indicating "Transaction has been logged". In step 620, the call to the TT logging service 26 is returned by sending an HTTP response with the XML parameter list to the origin of the HTTP request received in step 602.

In other preferred embodiments (not shown), the function of the TT logging service is extended so that it also may pre-select transactions which require a transaction tax calculation. In order to carry out such a pre-selection, the logging service is then invoked before the invocation of the TT calculation service for the first time. In these embodiments, it fetches and evaluates rules which indicate whether a transaction tax calculation is required for a given transaction, sets a corresponding flag and returns the transaction data together with this flag. Depending on the existence or absence of this flag, the process and communication layer 6 will then invoke the TT calculation service or will skip it. The logging service can be invoked a second time in order to perform the actual logging process, as was described above.

By using the described logging service it is ensured that the logged data are in compliance with the requirements of the pertinent jurisdiction. One and the same logging service can be used for the different jurisdictions of interest. The "content", i.e. the rules reflecting the logging requirements of the different jurisdictions can easily be configured by the user via a user interface, without the need to change hard-coded programs. The logging service can be invoked independently of other program components, such as transaction tax calculation components, and does not need logging-specific invocation parameters in order to perform the logging task. This enables the process layer to use independent services for TT calculation and TT logging. For example, an external service provider can be used for TT calculation, but the TT logging can be performed in-house by using the described TT logging service. Alternatively, a TT logging service of the described kind can be offered as an e-

service over the Internet. Such a service will not require the customer to specify whether and how a logging has to be performed for a given transaction. Rather, this determination can be offered as a part of the e-service.

5 The TT filing service 30 of Figs. 1 and 3 enables automatic preparation and filing of transition tax declarations for different jurisdictions.

Conventionally, transactional data, mostly in aggregated form, is retrieved by various reports, which are consolidated manually. Tax declaration forms have to be obtained from the tax authorities and filled out manually, based on the results of the manual report consolidation. The preparation of tax declarations for different jurisdictions requires different
10 ways of processing, and even changes of the official requirements in one jurisdiction may require changes in the processing. In contrast, the filing service 30 enables the tax declaration and filing to be carried out automatically. The processing is the same for different jurisdictions and remains unchanged when official requirements are changed. The filing service 30 is based on logged transaction data which have previously been generated by the
15 logging service 26 or any other suitable logging application. Since the data of certain transactions (in particular booking transactions) may be incomplete, the auto-completion service 42 (Fig. 1 and 9) is invoked preferably by the TT logging service 26 before logging the incomplete transaction data or after the logging step, but before the filing service 30 is invoked. The auto-completion service 42 completes such incomplete transaction data which
20 enables the preparation of the tax declaration according to the tax compliance requirements without manual intervention.

A tax declaration normally represents an aggregation of transaction data, in particular the calculation of total numbers, such as the total amount of transition tax received in the declaration time period. In jurisdictions with value added tax, also the total amount of
25 transition tax paid in the declaration time period as well as the difference between the received and paid amounts are calculated. Typically, the declaration has to be filed within short time intervals, for example monthly.

In order to initiate the filing process, the user has to input a corresponding request to the process and communication layer 6 (Fig. 1) via a user interface. Together with the
30 request, the user has to indicate for which country or jurisdiction the declaration shall be filed. In other, alternative embodiments, the tax filing process is initiated automatically when certain legal conditions are fulfilled, for example when the term of a tax declaration interval is reached, e.g. on the last day of each month. The process and communication layer 6 translates the user request or the automatically generated request into an HTTP request sent
35 to the filing service 30. The request has an argument representing tax-filing-related

information, such as the country or jurisdiction of the declaration to be prepared, the name of the company for which the declaration is to be prepared (if the automatic tax declaration filing is offered as a service for several companies); the time period which shall be covered by the tax declaration, etc.. Moreover, process-related data, such as an identification of the user who has initiated the filing process, is transmitted as argument. The argument data can, for example, be in the form of an XML document forming the body of the HTTP request. However, any other suitable invocation and parameter transmittal mechanism may be used.

In Fig. 8 the filing service 30 is shown in more detail. It is composed of a request verification component 702, a tax filing determination component 704, a transaction data selection component 706, a report execution component 708, and a tax filing component 710. The incoming tax filing request from the process and communication layer 6 is first processed by the request verification component 702. It verifies that certain conditions are fulfilled, for example, that the user who has initiated the filing process is authorized to do so, that the specified country or jurisdiction is existent and is one of the countries/jurisdictions which can be processed by the filing service 30, that the time interval for which the preparation of a tax report is requested is correct, etc. If the outcome of the request verification is negative, the tax filing process is either terminated (e.g. if the user is not authorized) or a message is sent to a message handler 712 asking for a confirmation by the user or another kind of user intervention (for example, if the tax declaration processing for the specified country and time interval has already been carried out, the user is asked to confirm that it should be repeated).

However, if the result of the request verification is positive, the tax filing determination component 704 is activated. Its task is to fetch report content rules and tax declaration templates for the country or jurisdiction for which the tax declaration shall be prepared from the content service 22. To this end, the tax filing determination component 704 sends a corresponding request to the content service 22 which, in turn, returns the requested rules and templates.

Then, the transaction data selection component 706 is activated. Its task is the selection of the transaction data records which are required for the preparation of the tax declaration on the basis of the original filing request and the rules received from the content service 22. More precisely, the transaction data selection component 706 has the actual selection carried out by the data warehouse 204. To this end, the selection component 706 translates the definition provided by the report content rules as to what transaction data are needed for the preparation of the present tax declaration into a corresponding Standard Query language (SQL) data retrieval command. This SQL command is sent to the data

warehouse 204, which in turn processes it, i.e. selects transaction data records from the stored transaction data according to the SQL command and returns the selected transaction data to the transaction data selection component 706.

5 After or during the data selection process, the report execution component 708 is activated. It has mainly two tasks: Its first task is to consolidate the selected transaction data. Consolidation means determination of numbers characterizing the selected transaction data globally, for example the total number of transactions, the accumulated amount of transaction tax received, the accumulated amount of transaction tax paid, the difference of these two accumulated amounts, etc. The way in which the transaction data are to be
10 consolidated is also defined in the report content rules fetched from the content service 22. The second task of the report execution component 708 is to enter the results of the transaction data consolidation into the corresponding fields of the text declaration template, which has also been received from the content service 22. The result is a finished tax declaration in compliance with the legal requirements of the jurisdiction in which the
15 declaration is to be filed. In some jurisdictions, it may be required to present not only consolidated data, but also individual transaction data. For these jurisdictions, the report execution component 708 appends a data record for each transaction in the legally required format, which can also be defined by the report content rules fetched from the content service 22.

20 The result of the process carried out by the report execution component 708 is a finished tax declaration in electronic form. For jurisdictions which allow an electronic filing of transaction tax declarations, the tax filing component 710 is then activated. It prepares the electronic tax declaration for transmission over a network (e.g. by encrypting it), opens a network connection to the tax authority's receiving server and dispatches the tax declaration
25 prepared in such way to the tax authority's receiving server. The network used for this dispatch may be the Internet or, for example, a telecommunication network which allows point-to-point access (such as a public telephone network). Also the actual payment of the accumulated transition tax may be effected automatically via an electronic bank transfer. To this end, an electronic transfer component (not shown) is provided in certain preferred
30 embodiments. If, however, the jurisdiction for which the tax declaration is to be prepared does not allow electronic filing of transition tax declarations, a hard copy of the electronic tax declaration prepared by the report execution component 708 is printed out and sent as a paper document to the tax authority.

35 The filing service 30 also has a tracing functionality: All steps carried out by the several components of the filing service 30 can be reported in the form of trace records which are

stored in the data warehouse 204. This enables the user to trace how the numbers appearing in the finished tax declaration have been generated. The tracing functionality not only serves as a debugging instrument. It can also serve as a proof for the correctness and compliance of the way in which the tax declaration has been prepared. Based on the stored
5 trace records, an official or internal auditor can verify the correctness and compliance of the tax declaration.

A user confirmation may also be requested at other stages of the tax filing preparation process than the above-described request verification stage. For example, before carrying out the actual electronic filing of the tax declaration by means of the tax filing component
10 710, the filing service 30 asks for a user confirmation. In addition, in preferred embodiments, the filing service 30 enables the user to intervene manually at different stages of the text declaration preparation process. For example, the user may be enabled to scan the transaction data selected by the transaction data selection component 706 and to change or discard transaction data records manually (however, it is generally preferred that such
15 manual interaction is avoided, in particular in view of the auto-completion functionality of the auto-completion service 42 which automatically completes incomplete transaction data records. The message handler 712 provides the user interface for these confirmation and intervention tasks. The communication is carried out by messages interchanged between the message handler 712 and the filing service 30.

The tax declaration templates as well as the rules which define which transaction data records have to be selected, how the selected transaction data are consolidated and where the results of the consolidation are to be put in the templates (called "report content rules") are contained in the content service 22 in a form configurable by the user. The report content rules and the tax declaration templates are not hard-coded in a content service 22 or the
25 filing service application 30. Rather, they can be input and modified by the user in a report content rules configuration interface 714 and a tax declaration templates configuration interface 716 which are both part of the content service 22. The report content rules can be entered by the user online in the form of a script language. After having fetched the script language content rules, the filing service 30 interprets them and processes them accordingly.
30 As already mentioned above, the content service 22 is shared between different basic services 8, and therefore also contains rules and "meta data" for the other basic services 8, as shown in Fig. 3. In other preferred embodiments (not shown) the content service is modular, the TT filing service 30 then has a specialized report content service component. Although it is generally possible that the filing service 30 fetches all report-related rules and
35 templates, it is preferred that it fetches only that subset of rules and templates which is

relevant for the jurisdiction or country for which the tax declaration is being prepared.

By using the described tax filing service, it is ensured that the evaluation of transaction tax data and the resulting tax declaration are in compliance with the requirements of the pertinent jurisdiction. One and the same filing service can be used for different jurisdictions, and the processing steps to be performed by the user are the same for all jurisdictions. The "content", i.e. the rules reflecting the tax declaration requirements as well as the templates can easily be configured by the user via a user interface, without the need to change hard-coded programs. The tax declaration is prepared automatically and can be filed electronically. The filing service is independent of other program components, such as transaction tax calculation components and logging components. This enables the process layer to use independent services for TT calculation, TT logging and TT filing. For example, an external service provider can be used for TT calculation, but the TT logging can be performed in-house by using the described TT filing service. Alternatively, a TT filing service of the described kind can be offered as an e-service over the internet. The transaction data records could, for example, be resident at the e-service's customer and send to the tax declaration service provider together with the request over the Internet.

Fig. 9 shows a exemplary flow chart of a method carried out by an auto-completion service module 42 according to a preferred embodiment of the invention. In the interest of a better understanding of this particular embodiment the normal situation when calling a particular TT service 22 to 40 will be briefly explained. Each time a particular TT service 22 to 40 is called a set of data elements, for example in the form of the tax object, might be transmitted which will be used by the called TT service 22 to 40 for performing its proper function. Furthermore, the called TT service 22 to 40 might have access to further data elements, such as are stored in the data warehouse. However, the situation might occur that a particular TT service 22 to 40 needs further information in order to accomplish its internal operations. This might be best seen with respect to the particular example of the logging service 26. When invoking the logging service 26 for logging tax-relevant information the situation might occur that the invoking TT service 22 to 40 transmits data elements which it generally considers to be sufficient for the logging service 26 to accomplish the logging operation. In particular, an invoking TT service 22 to 40 or external application might transmit all booking data listed in the general account book for a specific payment which has been received or made. However, the logging service 26 might recognize on the basis of the fetched logging rule for a particular country that it requires logging of the corresponding invoice number and date as well (for example in Germany, some legal entities like partnerships have to log balancing reports including invoice dates). This invoice number and

invoice date might not be transmitted among the data elements. According to the prior art a dialog with the user had to be opened enabling the user to manually enter the missing information.

According to the preferred embodiment of the invention shown in Fig. 9 this detrimental
5 situation will be avoided as follows: If the logging service 26 recognizes that it is not able to log a particular data element as required by the applied logging rule it might call the auto-completion service 42 depicted in Fig. 9. Thereby, it transmits transaction-related data elements comprising the missing data element identifier. The transaction-related data elements may further comprise all data elements currently used by the logging service 26 for
10 complying with the actual logging event. These data elements are preferably identical with or a subset of the standardized data model, the tax object, described with respect to Fig. 6. In the example shown in Fig. 9 the auto-completion service 42 is a software module forming a basic service which can be invoked independently of other basic services, for example by an HTTP request from the process and communication layer 6. Alternatively, the auto-completion service 42 might be implemented as a micro service in the overall TT structure or
15 might be directly integrated in form of a software component into the particular calling service (in this example into the logging service 26). Naturally, all other TT services 22 to 40 as discussed with the respect to Figs. 1 to 8 may benefit from an auto-completion function. In particular, the TT compliance report service 28 profits from such an auto-completion function
20 as a lot of transactions like direct G/L entries do not carry all information required by the particular compliance report. Moreover, as discussed with respect to Figs. 1 and 3 the compliance report service 28 may consider different reporting areas (management, audits, etc.) all having different reporting needs. Finally, it will reduce different interpretations of these kinds of transactions by different users and enable one compliance view. In addition,
25 the various different data extractions for compliance reporting will be reduced to exceptions only. The preferred embodiment particularly solves the problem of the prior systems that hard copied information needed to be stored somewhere in the system in order to enable tracking and verifying correctness of transactions (which often was forgotten and needed to be manually added for each transaction).

30 Returning to Fig. 9 the steps performed by the auto completion service module 42 will be discussed in more detail. In step 802 the module 42 receives the transmitted data elements (for example by means of an interface component), in particular the missing data element identifier. In an optional step 804 it might fetch a set of completing rules from the content management service 22 in a user-configurable form. As already discussed with
35 respect to the logging service 26 shown in Fig. 7 the content management service 22 also

contains other rules and "meta data" for other basic services (see above). The auto completion service 42 might fetch only a subset of completing rules concerning the particular missing data element. If the step 804 is not provided the auto completion service 42 might contain an internally stored set of completing rules for all or a subset of missing data elements (in the latter case, different auto completion services 42 associated to different TT services 22 to 40 may be provided which only need the subset of missing data elements occurring in the specific TT service 22 to 40). In a step 806 it applies the set of completing rules (for example by means of an evaluation component) with regard to the missing data element while having access to the transmitted data elements as well as to data elements stored in the data warehouse, etc. In general, the completing rules are similar to the mapping rules described with regard to the above preferred embodiments of the invention. The difference, however, between these rules lies in the specific certainty a missing data element might be identified by both sets of rules. In the above mapping rules, each data element is exactly determined from one or a set of source fields (in the above example, the "line item amount" used by the TT calculation service 24 is exactly determined from the source field "prices_netprice", similarly, the "currency" is exactly determined from the "customer_country" and "date_year" source fields). If for example a booking in the general account book lacks the corresponding invoice number(s) or date(s) (cp. above) this number might be derived from the customer name identified among the information for this booking. A corresponding completing rule might enable the auto-completion service 42 in step 806 to search the data warehouse for the customer name and for corresponding invoice numbers. The simplest case occurs if only one invoice number will be found. Then, the booking will most probably correspond to the found invoice number which may be further verified by comparing the found invoice amount and the booking amount in the ledger. A more complicated case occurs if several invoice numbers are found and none of the corresponding invoice amounts corresponds to the booking amount in the ledger. Then, a kind of artificial intelligence implemented in more complex completing rules might try to add all open invoice amounts or all combinations of open invoice amounts and compare the results with the booking amount. A correspondence between such a combination and the booking amount implies a likely relationship of the missing invoice numbers and the booking amount.

Preferably, the completing rules are not hard coded in the content management service 22 or the auto-completion service module 42. Rather, the completing rules can be input and modified by the user via a completing rule configuration interface which may be part of the content management service 22 or the auto-completion-module 42. The completion rules can be entered by the user online in the form of a script language.

Moreover, the "intelligent" completing rules might be configured to consider jurisdictional requirements when completing missing information. For example, if an outside invoice merely shows the gross amount (i.e. the before-tax amount and the value added tax rate are added and not separately listed in the invoice) the auto-completion service module 42 might calculate the value added tax rate on the basis of the addressee's location, the corresponding jurisdiction to be applied and the listed gross amount. However, some jurisdictions (for example the German jurisdiction) might generally forbid the derivation of value added tax rates from gross amounts. Consequently, in such a case the auto-completion service 42 might notify the user about this particular event in a step 808 (for example by means of an optional notification component), i.e. that it will consider the gross amount not to contain a value added tax rate. Generally, if the applied completing rules lead to the result that the missing data element should not be derived from other information due to legal or other requirements the user will be notified and the auto-completion service 42 returns to the invoking service in step 810.

Otherwise the likelihood of the determined value for the missing data element to be valid will be evaluated in a plausibility test 812 (for example by means of a plausibility checking component). Therein, the likelihood may either be determined on the basis of a fixed certainty value associated with the corresponding completing rule leading to the determined value for the missing data element. This fixed certainty value might for example indicate that this completing rule leads most likely or only vaguely to the information for the missing data element. Apparently, there are numerous other possibilities for deriving such a certainty value. Preferably, the plausibility test returns the certainty value according to the following procedure. As can be seen from the above particular examples, there are numerous possibilities for implementing completing rules deriving information about missing data elements. Therefore, several different completing rules may be configured to get several suggestions about the missing data element from several different sources. The set of suggestions obtained will then be evaluated by means of the plausibility tests. A very simple plausibility test would consist of comparing all suggestions delivered by this set of completing rules and setting a certainty value either to "most likely" if all suggestions are equal to each other or to "vague" if at least one suggestions differs from the other ones.

The service module 42 then proceeds to step 814 where the certainty value is compared with a predetermined threshold parameters, for example "most likely" and "vague". If the certainty value is equal to "vague" the auto-completion service 42 proceeds to step 816 where it opens a dialog routine with the user suggesting its particular result or results for completing the missing data element and asking for confirmation of the suggested result or

for selection of one of the several results. Furthermore, the user might be enabled during this dialog to enter a completely different value for the missing data element if the suggestions are not acceptable. Naturally, the service 42 also proceeds to step 816 when it is unable to obtain any value for the missing data element and asks for manual entry of the data element.

5 If in step 814 the certainty value is determined to be equal to the threshold parameter "most likely" the auto-completion service 42 will directly proceed to step 818. Similarly, step 808 subsequently proceeds to step 818 either with the confirmed suggestion, the selected suggestion of the missing data element or the user-entered value of the missing data element. In step 818 the auto-completion service 42 returns the missing data element to the
0 invoking TT service 22 to 40.

Summarizing, subject to certain reporting requirements defined by tax authorities (cp. the description with respect to the filing service 30), by the company management, the audit requirements and others as appropriate, the auto completion service 42 intelligently and as far as possible automatically calculates or supplies missing information.

15 With the preferred embodiments, a more flexible and effective data exchanging functionality is provided than it was previously the case. Thus, a general purpose of the preferred embodiments is to provide improved methods, an improved data record, software interface, data warehouse module and software application for transaction-tax data exchange.

20 All publications and existing systems mentioned in this specification are herein incorporated by reference.

Although certain methods and products constructed in accordance with the teachings of the invention have been described herein, the scope of coverage of this patent is not limited thereto. On the contrary, this patent covers all embodiments of the teachings of the
25 invention fairly falling within the scope of the appended claims either literally or under the doctrine of equivalents.

What is claimed is:

1. A computer-based method performed in a first transaction-tax-related application,
5 the method comprising:
 exchanging transaction-related data with at least a second transaction-tax-related application according to a standardized transaction-tax interface data model.
2. The method of claim 1, wherein the first transaction-tax-related application uses a
10 first application-specific data model, the method further comprising:
 mapping data elements of the first application-specific data model to data elements of the standardized transaction-tax interface data model, or vice versa.
3. The method of claim 1 or 2, being further performed in the second transaction-
15 tax-related application, which uses a second application-specific data model, the method comprising:
 mapping data elements which are exchanged according to the standardized transaction-tax interface model to data elements of the second application-specific data model, or vice versa.
20
4. The method of claim 3, wherein the first and second application-specific data models are different from the standardized transaction-tax interface model.
5. The method of claim 3 or 4, wherein the first and second application-specific data
25 models are different from each other.
6. The method of any one of claims 1, 3 and 5, wherein the first transaction-tax-related application uses a first application-specific data model, and the first application-specific data model corresponds to the standardized transaction-tax interface data model.
30
7. A computer-based method performed in a transaction-tax-related data warehouse application, the method comprising:
 storing transaction-related data received from at least one other transaction-tax-related application in a data warehouse according to a standardized transaction-tax data warehouse
35 data model.

8. The method of claim 7, comprising exchanging transaction-related data stored or to be stored in the data warehouse with the other transaction-tax-related application according to a standardized transaction-tax interface data model.

5

9. The method of claim 8, wherein the tax-related data warehouse data model has a set of transaction-tax-related data elements and the standardized transaction-tax interface data model has a set of transaction-tax-related data elements, the set of transaction-tax-related data elements of the tax-related data warehouse data model comprises, equals or is a subset of the set of transaction-tax-related data elements of a standardized transaction-tax interface data model.

0

10. The method of any one of claims 1 to 9, wherein at least one of the first and the second transaction-tax-related transaction applications are one of the following modules:

15

- i) a transaction tax logging module,
- ii) a transaction tax compliance module,
- iii) a transaction tax filing module,
- iv) a transaction tax calculation module,
- v) a transaction tax content module, and
- vi) a transaction tax database for storing transaction-related data.

20

11. The method of any one of claims 1 to 10, wherein at least one of the first and the second transaction-tax-related applications is one of a basic and a micro service module.

25

12. The method of any one of claims 2 to 11, wherein the way the mapping is governed is defined by rules that are configurable by a user.

13. The method of claim 12, wherein the rules are implemented by a lookup table.

30

14. A data record according to a standardized transaction-tax interface data model, comprising transaction-related data items, for the data exchange between transaction-tax-related applications or modules.

35

15. The data record of claim 14, wherein the transaction-tax interface data model, on which the data record is based, is defined so as to provide data elements at least for a first

jurisdiction and a second jurisdiction, wherein the transaction-tax interface data model has at least one first data element which is used for the first jurisdiction, but is not used for the second jurisdiction, and at least one second data element which is used for the second jurisdiction, but is not used for the first jurisdiction.

5

16. The data record of claim 14 or 15, which is exchanged as an argument when a transaction-tax-related application or module is invoked.

17. The data record of claim 16, wherein the transaction-tax-related application or
10 module is invoked by an HTTP request, and the exchanged argument is an XML document forming a part of the HTTP request.

18. A software interface for linking a first transaction-tax-related application with at
least a second transaction-tax-related application, the interface being implemented such that
15 data are exchangeable between the first and the second transaction-tax-related application according to a standardized transaction-tax interface data model.

19. The software interface of claim 18, wherein the first transaction-tax-related
application uses a first application-specific data model, the software interface comprising a
20 first mapping component for mapping data elements of the first application-specific data model to data elements according to the standardized transaction-tax interface data model, or vice versa.

20. The software interface of claim 18 or 19, wherein the second transaction-tax-
25 related application uses a second application-specific data model, the software interface comprising a second mapping component for mapping data elements, which are exchanged according to the standardized transaction-tax interface model, to data elements of a second application-specific data model, or vice versa.

30 21. The software interface of claim 20, wherein the first and second application-specific data models are different from the standardized transaction-tax interface model.

22. The software interface of claim 20 or 21, wherein the first and second application-specific data models are different from each other.

35

23. The software interface of any one of claims 18, 20 and 22, wherein the first transaction-tax-related application uses a first application-specific data model, and the first application-specific data model corresponds to the standardized transaction-tax interface data model.

5

24. A computer-based data warehouse module, configured for storing transaction-related data received from at least one other transaction-tax-related application according to a standardized transaction-tax data warehouse data model.

0

25. The module of claim 24, comprising a software interface for linking the data warehouse module with at least a second transaction-tax-related application, said software interface being implemented such that data are exchangeable between the data warehouse application module and the second transaction-tax-related application according to a standardized transaction-tax interface data model.

5

26. The module of claim 25, wherein the tax-related data warehouse data model has a set of transaction-tax-related data elements and the standardized transaction-tax interface data model has a set of transaction-tax-related data elements, the set of transaction-tax-related data elements of the tax-related data warehouse data model comprises, equals or is a subset of the set of transaction-tax-related data elements of the standardized transaction-tax interface data model.

20

27. The interface or module of any one of claims 18 to 26, wherein at least one of the first and second transaction-tax-related transaction applications are one of the following modules:

25

- i) a transaction tax logging service module,
- ii) a transaction tax compliance module,
- iii) a transaction tax filing module,
- iv) a transaction tax calculation module,
- v) a transaction tax content module, and
- vi) a transaction tax database for storing transaction-related data.

30

28. The interface or module of any one of claims 18 to 27, wherein at least one of the first and second transaction-tax-related applications is one of a basic and a micro service module.

35

29. The interface or module of any one of claims 18 to 28, wherein the mapping component enables a user to input and configure rules which define how the data element mapping is performed.

5

30. The interface or module of claim 29, wherein the rules are implemented via a lookup table.

31. A transaction-tax-related software application including an interface for linking the application with at least a second transaction-tax-related application, the interface being implemented such that data are exchangeable between the first and the second transaction-tax-related application according to a standardized transaction-tax interface data model.

10

FIG.1

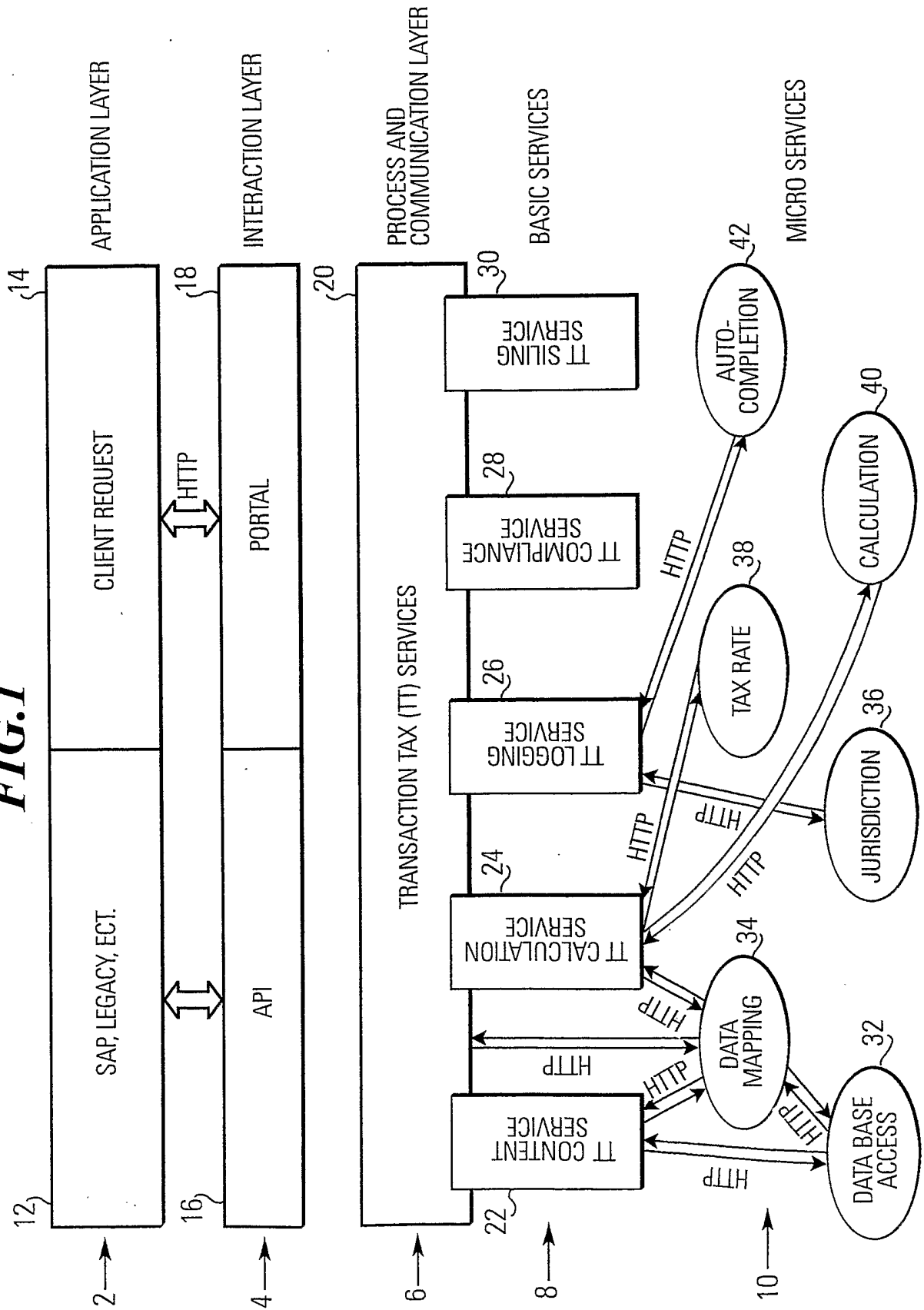

FIG.2

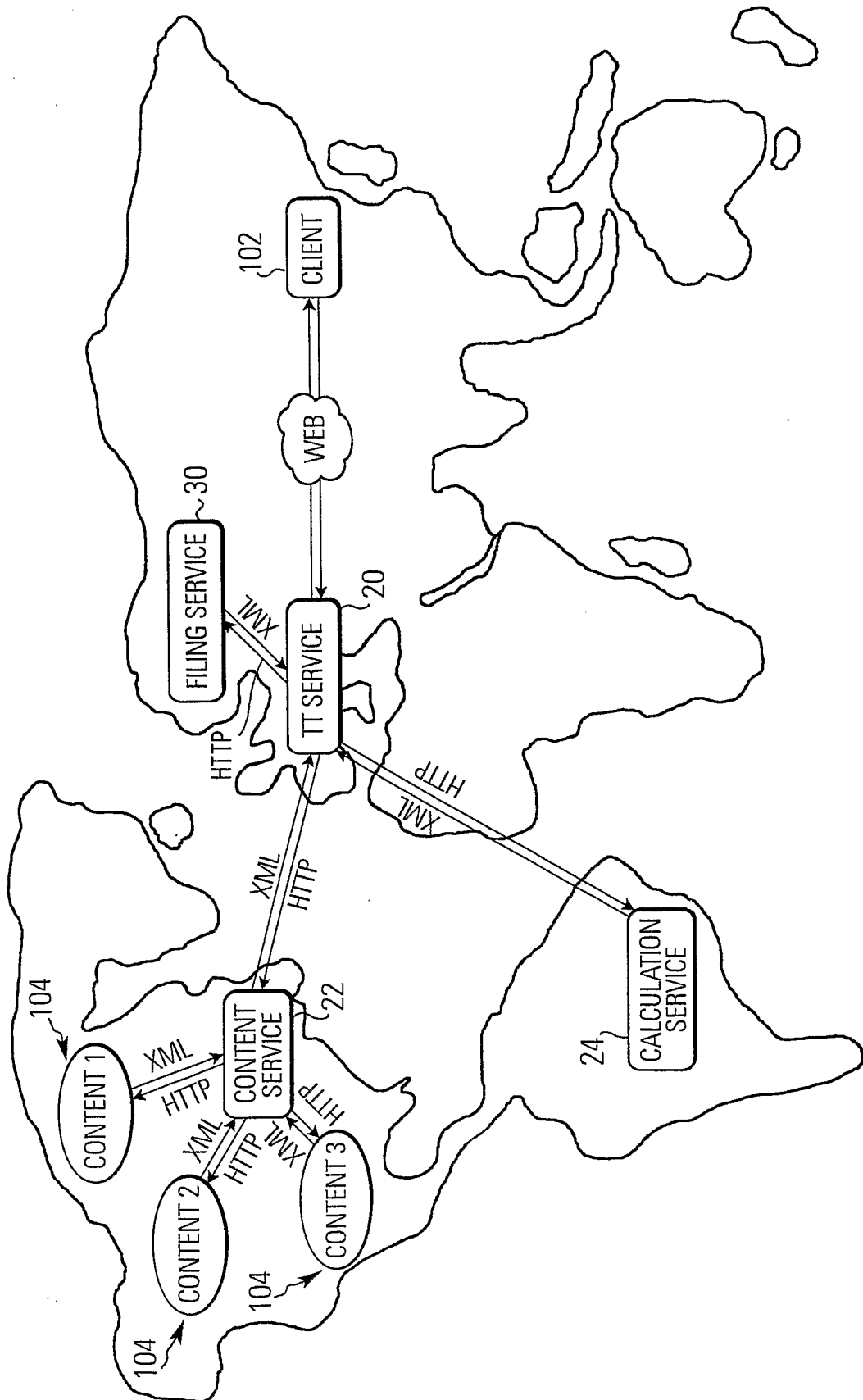

FIG.3

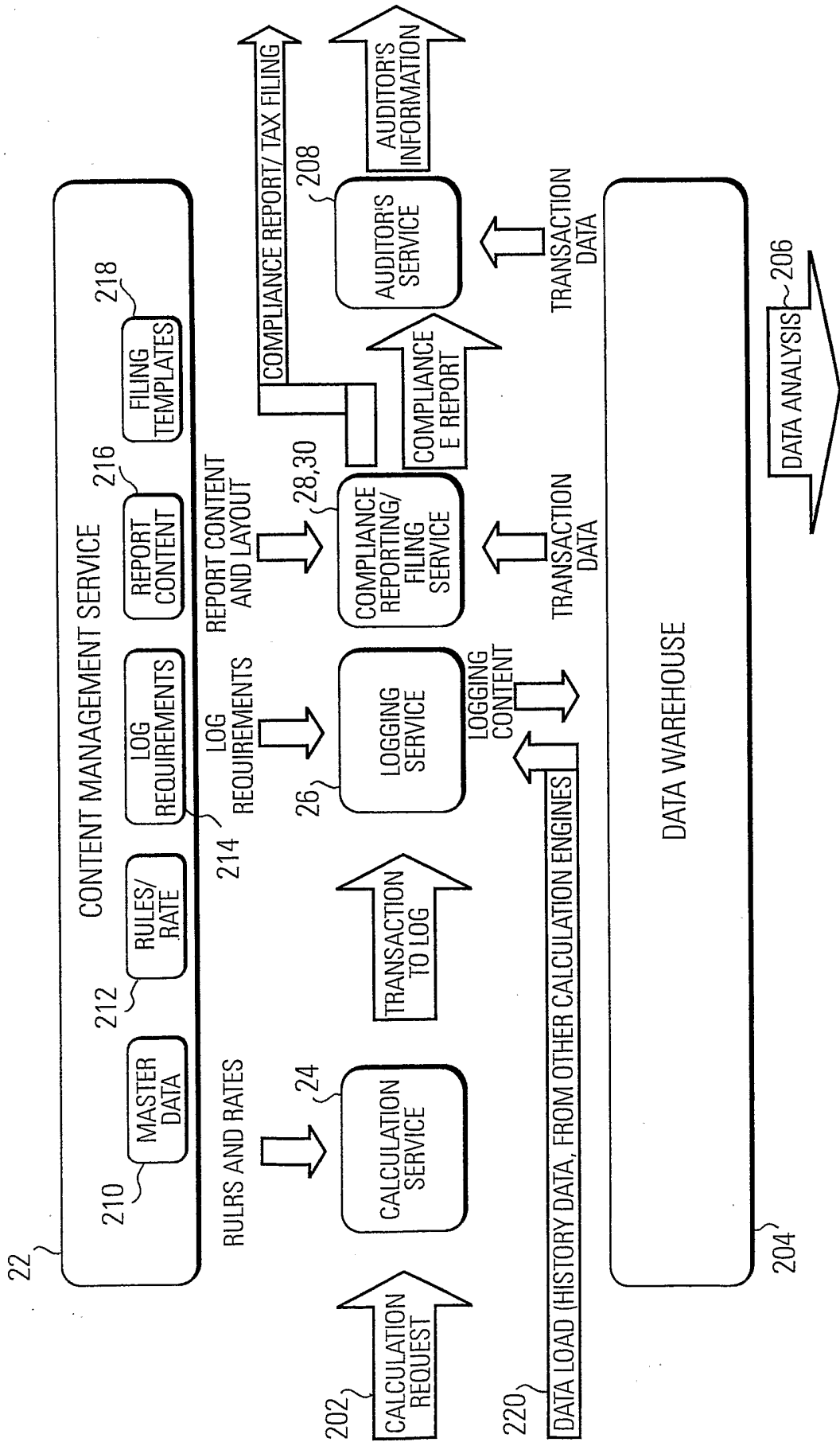
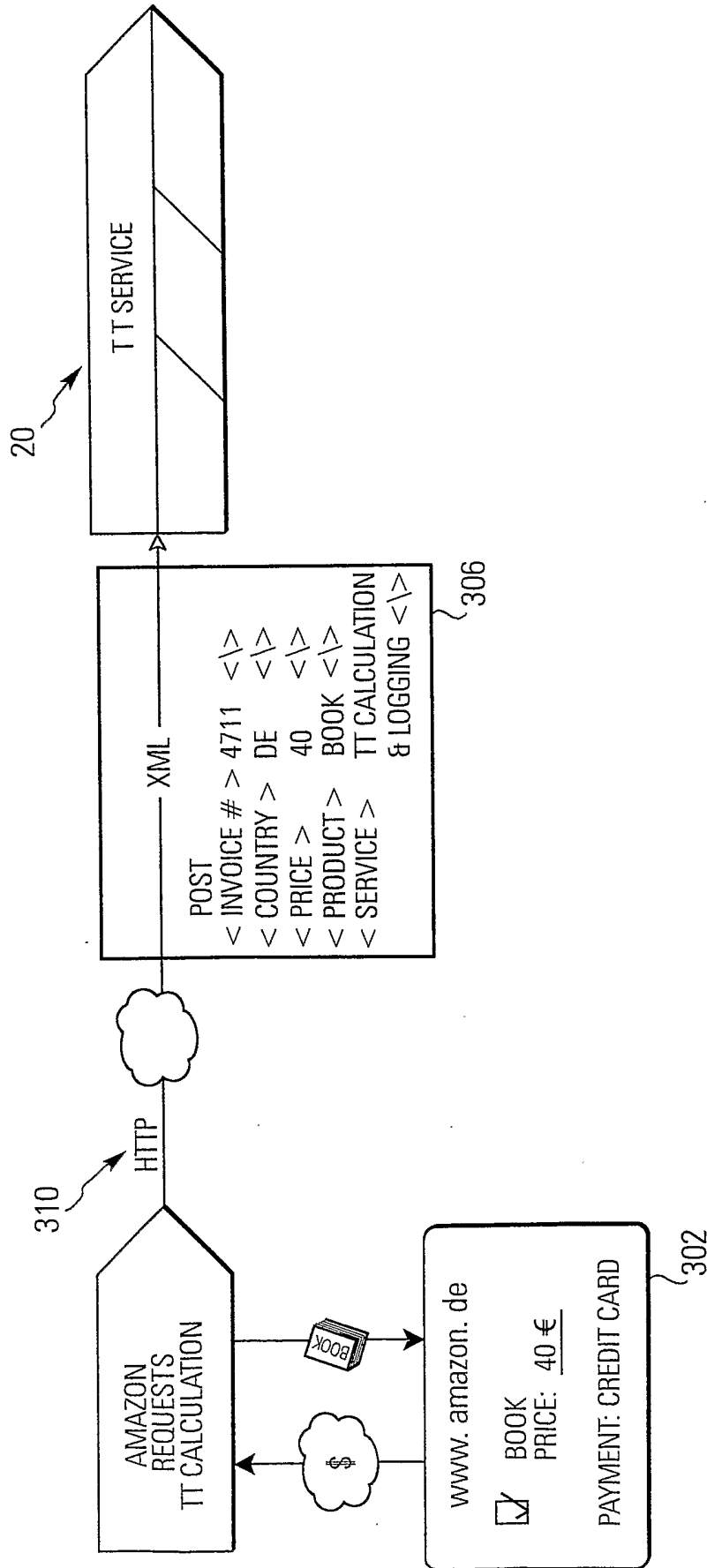

FIG. 4a



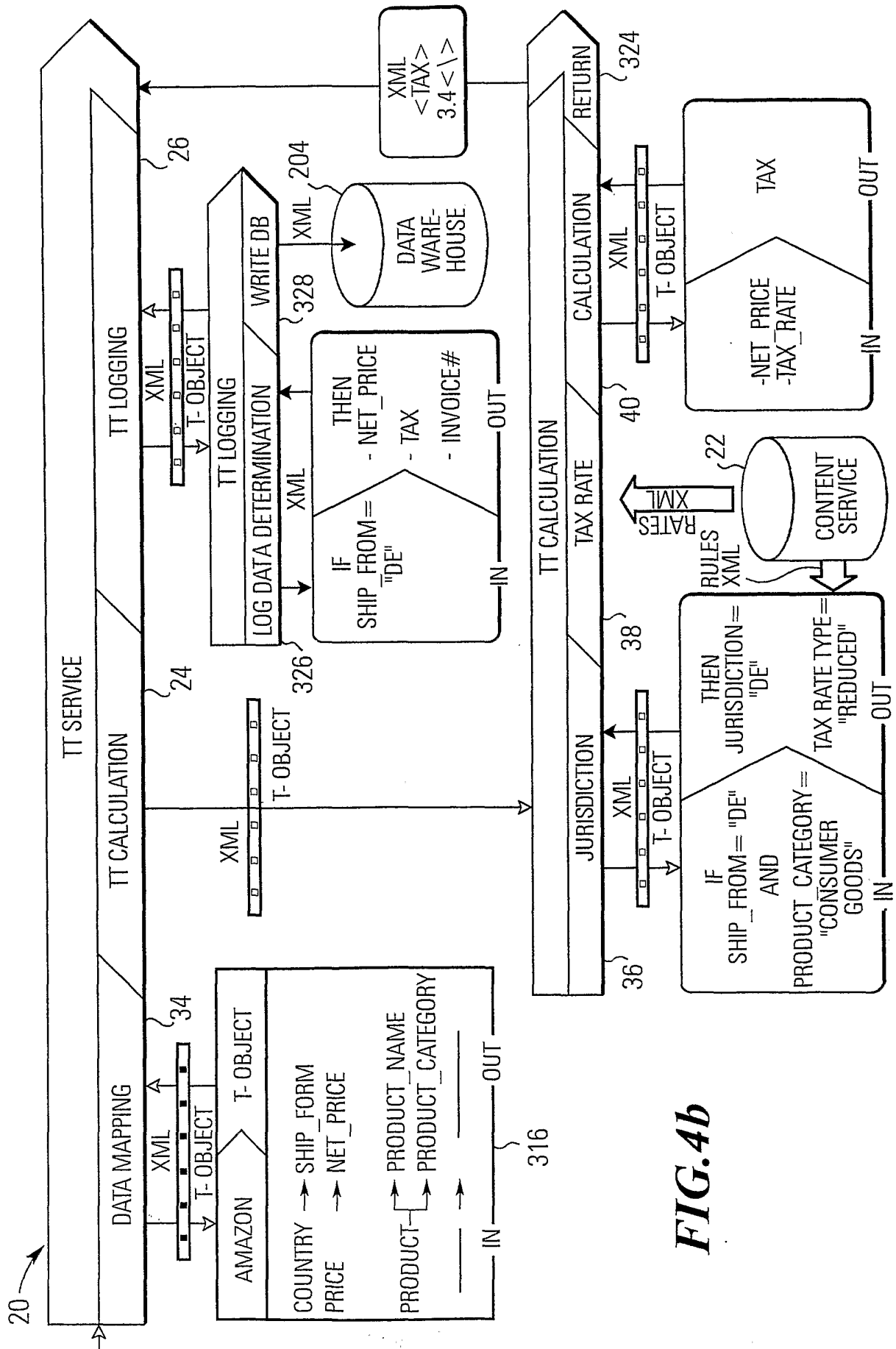

FIG. 4b

FIG. 5a

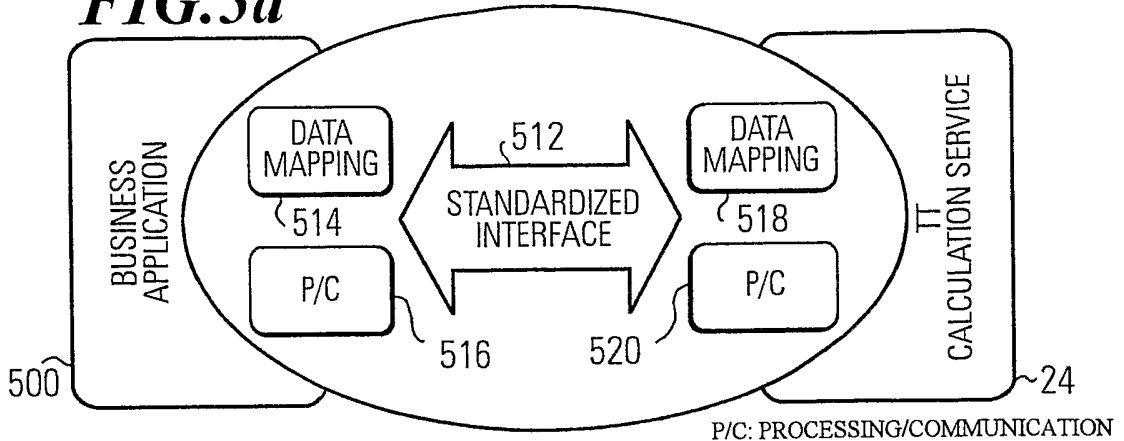

FIG. 5b

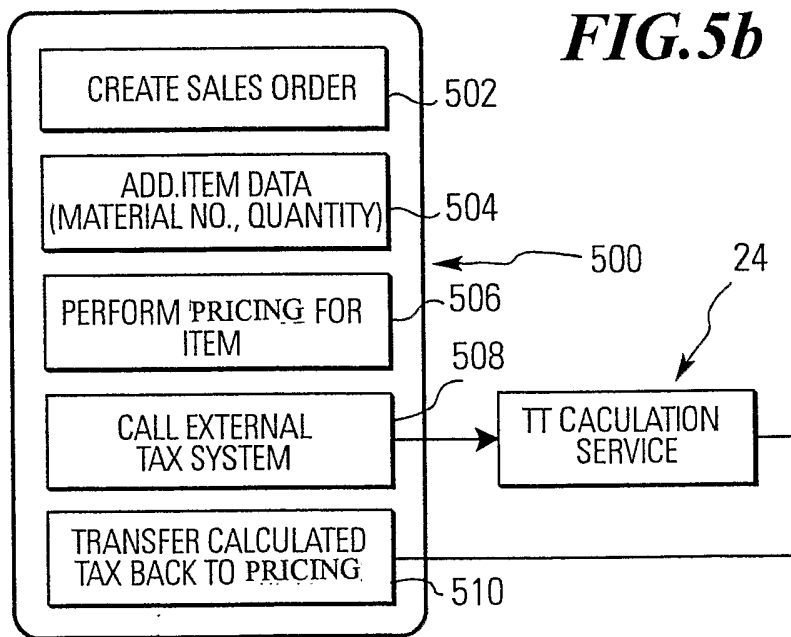

FIG. 5c

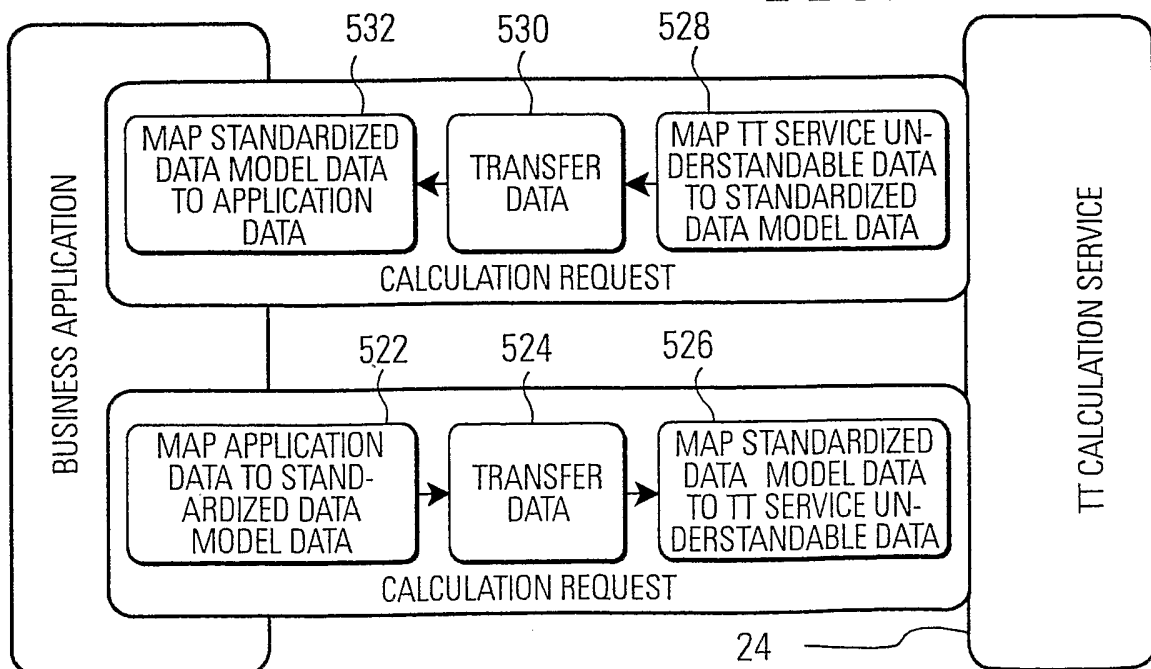

FIG. 5d

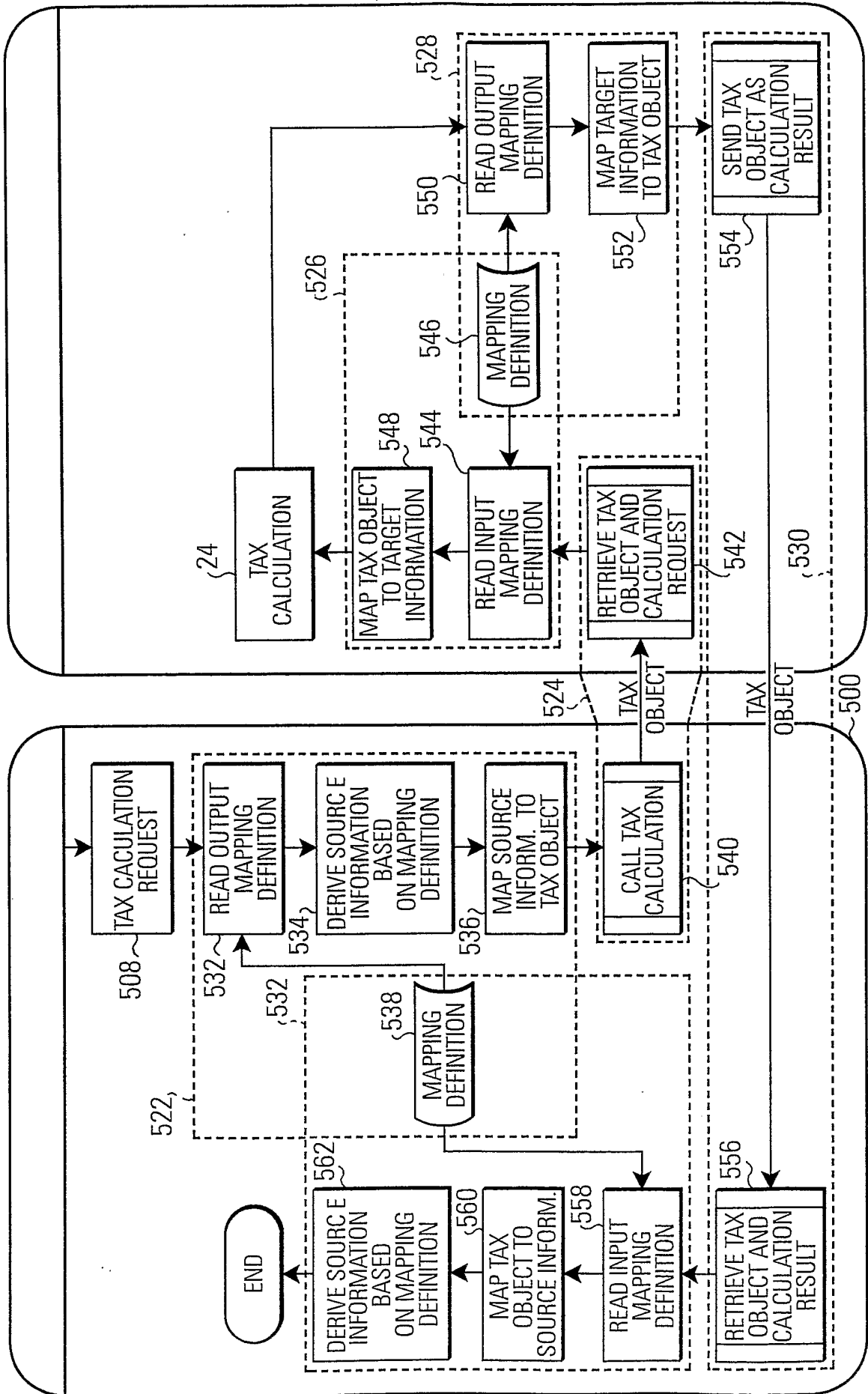
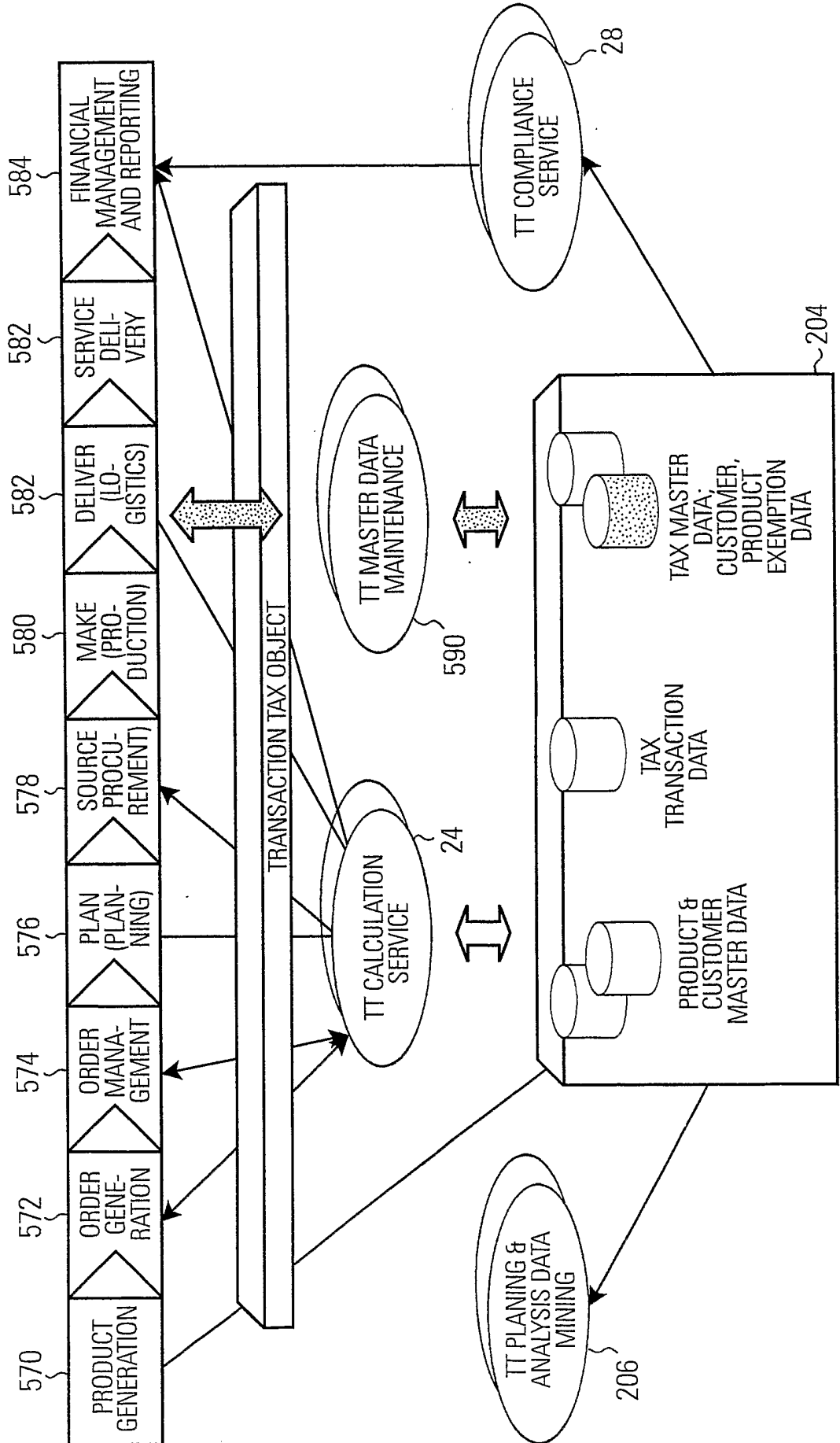

FIG. 5e



9/19

FIG.6

INBOUND ELEMENTS

FIELD NO.	DATA ELEMENT	SUB DATA ELEMENT	TYPE	DESCRIPTION	REQUIRED
1.	COMPANY- ID			LEGAL ENTITY, WHICH IS ASSO- CIATED THE TRANSACTION	x
2.	DIVISION			USED IN REPORTING TO IDENTIFY THE BUSINESS WITHIN A COMPANY	
3.	CREATOR			APPLICATION, WHICH PASSES TRANSACTION TO TRXN TAX ENGINE	
4.	SHIP- FROM ADDRESS			SHIP- FROM LOCATION ADDRESS	x
5.		STREET		STREET ADDRESS	
6.		TERRITORY		TERRITORY	
7.		PROVINCE		PROVINCE, USED FOR JURIS- DICTION PROCESSING FOR US	
8.		COUNTY		COUNTY	
9.		CITY		CITY	
10.		POSTAL CODE		POSTAL CODE	
11.		STATE		STATE	
12.		COUNTRY		ISO COUNTRY CODE	
13.	DESTINATION/SHIP- TO ADDRESS			SHIP- TO ADDRESS FOR GOODS, PERFORMED- AT- ADDRESS FOR SERVICES	x
14.		NAME		NAME OF COMPANY RECEIVING GOODS OR SERVICES	
15.		STREET		STREET ADDRESS	
16.		TERRITORY		TERRITORY	
17.		PROVINCE		PROVINCE, USED FOR JURIS- DICTION PROCESSING FOR US	
18.		COUNTY		COUNTY	
19.		CITY		CITY	
20.		POSTAL CODE		POSTAL CODE	
21.		STATE		STATE	
22.		COUNTRY		ISO COUNTRY CODE	
23.	ORIGIN/ POO ADDRESS			SELLER ADDRESS, FOR US POINT OF ORDER ORIGIN	
24.		STREET		STREET ADDRESS	
25.		TERRITORY		TERRITORY	
26.		PROVINCE		PROVINCE, USED FOR JURISDICTION	

10/19

FIELD NO.	DATA ELEMENT	SUB DATA ELEMENT	TYPE	DESCRIPTION	REQUIRED
				PROCESSING FOR US	
27.		COUNTY		COUNTY	
28.		CITY		CITY	
29.		POSTAL CODE		POSTAL CODE	
30.		STATE		STATE	
31.		COUNTRY		ISO COUNTRY CODE	
32.	POA ADDRESS			POINT OF ORDER ACCEPTANCE ADDRESS	
33.		STREET		STREET ADDRESS	
34.		TERRITORY		TERRITORY	
35.		PROVINCE		PROVINCE, USED FOR JURISDICTION PROCESSING FOR US	
36.		COUNTY		COUNTY	
37.		CITY		CITY	
38.		POSTAL CODE		POSTAL CODE	
39.		STATE		STATE	
40.		COUNTRY		ISO COUNTRY CODE	
41.	INVOICE- TO ADDRESS			INVOICE-TO/ BILL-TO ADDRESS	
42.		NAME		NAME OF COMPANY RECEIVING INVOICE	
43.		STREET		STREET ADDRESS	
44.		TERRITORY		TERRITORY	
45.		PROVINCE		PROVINCE, USED FOR JURISDICTION PROCESSING FOR US	
46.		COUNTY		COUNTY	
47.		CITY		CITY	
48.		POSTAL CODE	CHAR(5)	POSTAL CODE	
49.		STATE		STATE	
50.		COUNTRY		ISO COUNTRY CODE	
51.	SOLD- TO ADDRESS			ADDRESS OF THE CONTRACTUAL RELATIONSHIP	
52.		NAME		NAME OF COMPANY	
53.		STREET		STREET ADDRESS	
54.		TERRITORY		TERRITORY	
55.		PROVINCE		PROVINCE, USED FOR JURISDICTION PROCESSING FOR US	
56.		COUNTY		COUNTY	
57.		CITY		CITY	
58.		POSTAL CODE	CHAR(5)	POSTAL CODE	
59.		STATE		STATE	

11/19

FIELD NO.	DATA ELEMENT	SUB DATA ELEMENT	TYPE	DESCRIPTION	REQUIRED
60.		COUNTRY		ISO COUNTRY CODE	
61.	POINT- OF- TITLE PASSAGE			LOCATION AT WHICH LEGAL TITLE HAS TRANSFERRED TO THE PURCHASER (POO/SHIP FROM LOCATION.SHIP-TO LOCATION) US-ONLY	
62.	TRANSACTION TYPE			DESCRIBES THE TYPE OF TRANSACTION (SALES OR PURCHASE)	
63.	KIND OF TRANSACTION			DESCRIBES THE TRANSACTION (NORMAL PURCHASE/SALES, LEASE, RENTAL, RETURN....)	
64.	INVOICE DATE/TAX POINT			DATE INVOICE IS ISSUED. USED AS REFERENCE FOR TAX CALCULATION. FOR CREDIT/ CORRECTIONS, THIS NEED TO BE THE ORIGINAL DATE OF THE INVOICE	
65.	DELIVERY DATE/ TRANSACTION DATE			DATE GOODS ARE DELIVERED, SHIPPED OR MOVED	
66.	MODE OF TRANSPORT			DESCRIBE MEANS BY WHICH THE GOODS ARE TRANSPORTED (SEA, RAIL, ROAD, AIR)	
67.	COMMODITY/SERVICE CODE (PRODUCT CODE FOR US)			IDENTIFIES THE TYPE OF PRODUCT AND IS NEEDED FOR TAX RATE DETERMINATION	
68.	CREDIT/CORRECTION INDICATOR			IDENTIFIES CREDIT/CORRECTION TRANSACTION	
69.	REASON CODE			REASON FOR EXEMPTION FROM TAX (US ONLY)	
70.		COUNTRY			
71.		STATE/PROVINCE			
72.		COUNTY			
73.		CITY			
74.	TAX CERTIFICATE NUMBER			TAX CERTIFICATE NUMBER, WHICH INDICATES THAT THE TRANSACTION IS EXEMPT FROM TAXES	
75.		COUNTRY			
76.		STATE/PROVINCE			
77.		COUNTY			
78.		CITY			
79.	EXEMPTION CERTIFICATE TYPE			KEY TYPE OF CERTIFICATE (US ONLY)	
80.	INVOICE/DOKUMENT NUMBER			DOCUMENT NUMBER	
81.	CUSTOMER NUMBER			UNIQUE IDENTIFICATION FOR CUSTOMER	
82.	CUSTOMER NAME				
83.	CONTRACT NUMBER			CONTRACT RELATED TO TRANSACTION	
84.	CURRENCY			CODE IDENTIFYING THE CURRENCY USED ON DOCUMENT	
85.	UNIT OF MEASURE				

12/19

FIELD NO.	DATA ELEMENT	SUB DATA ELEMENT	TYPE	DESCRIPTION	REQUIRED
86.	PRODUCT NUMBER			NUMBER OF PRODUCT	
87.	PRODUCT DESCRIPTION			DESCRIPTION OF GOOD OR SERVICE	
88.	ORIGINAL DOCUMENT NUMBER			REFERENCE TO ORIGINAL DOCUMENT. USED FOR CREDIT/CORRECTION TRANSACTIONS	
89.	DOCUMENT TYPE			ORDER, TRADE INVOICE, PURCHASE ORDER, BILL OF LADING	
90.	AGENT INDICATOR			AGENT USED FOR REPORTING OF THIS TRANSACTION	
91.	COUNTRY OF ORIGIN			COUNTRY IN WHICH GOODS ORIGINATE OR PLACE, WHERE THE LAST SIGNIFICANT PROCESSING OR MANUFACTURING TOOK PLACE	
92.	DESTINATION CODE			REGION OF DISPATCH/ARRIVAL, WHERE THE GOODS ARE PRODUCED, ASSEMBLED, PROCESSED, REPAIRED OR MAINTAINED (EU ONLY)	
93.	DELIVERY TERM			FREIGHT CODE REPRESENTING TERMS OF TRADE BETWEEN A BUYER AND A SELLER (INCO TERMS)	
94.	PORT OF LOADING			NATURE OF TRANSACTION	
95.	DISTANCE SALE INDICATOR			TRANSACTION IS A DISTANCE SALE. ALLOWS TO DISTINGUISH SALES ABOVE AND UNDER THE THRESHOLD	
96.	STATISTICAL PROCEDURE			FLOW AND PROCESS OF MERCHANDISE. (EU ONLY- INTRASTAT)	
97.	NEW MEANS OF TRANSPORT INDICATOR			TRANSACTION INVOLVES NEW MEAN OF TRANSPORT	
98.	AFFILIATION			INDICATES AN AFFILIATION BETWEEN DECLARANT AND BUSINESS PARTNER	
99.	FISCAL DATE			DATE FOR WHICH THE TRANSACTION IS REPORTED	
100.	TAX LEVEL			DEFINE AT WHICH JURISDICTION LEVEL TAX SHOULD BE CALCULATED (US ONLY)	
101.	SELLER REGISTRATION NUMBER			IN CASE THIS FIELD IS FILLED, TAX ENGINE WILL NOT CHECK AGAINST THEIR COMPANY LEGAL STRUCTURE	
102.	BUYER REGISTRATION NUMBER			TAX REGISTRATION NUMBER OF BUYER	
103.	AGENT REGISTRATION NUMBER				
104.	OVERRIDE TAX RATE			OVERRIDE OVER SYSTEM DETERM. TAX RATE. USED TO PASS A TRANSACTION ONLY INTO THE AUDIT FILE	
105.		TERRITORY			
106.		PROVINCE			
107.		COUNTY			
108.		CITY			
109.		STATE			

FIELD NO.	DATA ELEMENT	SUB DATA ELEMENT	TYPE	DESCRIPTION	REQUIRED
110.		COUNTRY			
111.	OVERRIDE TRXN TAX AMOUNT			OVERRIDE OVER SYSTEM DETERMINED TAX RATE. USED TO PASS A TRANSACTION ONLY INTO THE AUDIT FILE	
112.		TERRITORY			
113.		PROVINCE			
114.		COUNTY			
115.		CITY			
116.		STATE			
117.		COUNTRY			
118.	INVOICE LINE NUMBER				
119.	INVOICE SUMMARY INDICATOR			INDICATES, THAT THIS TRANSACTION LINE REPRESENTS AN INVOICE SUMMARY	
120.	LINE ITEM AMOUNT			PRICE OF GOODS/SERVICES ON THE LINE ITEM	
121.	OVER TAX AMOUNT			ANY DUTY OR EXTRANEIOUS TAX AMOUNTS	
122.	DISCOUNT AMOUNT			AMOUNT BEING DISCOUNTED FOR THE INVOICE OR THE LINE ITEM	
123.	FREIGHT AMOUNT			COST ASSOCIATED WITH THE TRANSPORTATION	
124.	INSURANCE AMOUNT			COST OF INSURANCE ON GOODS RELATING TO GOODS FLOW	
125.	EXEMPT AMOUNT			AMOUNT OF THE TRANSACTION, WHICH IS EXEMPT FROM TAX	
126.		TERRITORY			
127.		PROVINCE			
128.		COUNTY			
129.		CITY			
130.		STATE			
131.		COUNTRY			
132.	INSURANCE AMOUNT FOREIGN			INSURANCE ON GOODS RELATED TO THE PART OF THE FLOW, WHICH TOOK PART OUTSIDE OF TAXATION JURISDICTION	
133.	FREIGHT AMOUNT FOREIGN			FREIGHT AMOUNT RELATED TO THE PART OF THE FLOW, WHICH TOOK PART OUTSIDE OF TAXATION JURISDICTION	
134.	REDUCED BAIS PERCENTAGE			USED TO REDUCE THE TAXABLE GROSS AMOUNT BEFORE CALCULATING TAX (US)	
135.	CURRENCY CONVERSION FACTOR			USED TO CONVERT AMOUNTS FOR REPORTING/INVOICING PURPOSES	
136.	NET/MASS/VOLUME			WEIGHT/VOLUME OF GOODS INVOLVED IN TRANSACTION	
137.	RECOVERABLE PERCENTAGE			PERCENTAGE USED TO CALCULATE RECOVERABLE AMOUNT (DEFAULT= 100%)	

OUTBOUND ELEMENTS

FIELD NO.	DATA ELEMENT	SUB DATA ELEMENT	TYPE	DESCRIPTION
1.	COMPLETION CODE			CODE PROVIDING INFORMATION HOW THE SYSTEM HAS PROCESSED THE TRANSACTION
2.		OVERALL		
3.		COUNTRY		
4.		TERRITORY		
5.		STATE		
6.		PROVINCE		
7.		COUNTY		
8.		CITY		
9.	OVERALL COMPLETION CODE DESCRIPTION			DESCRIPTION COMPLETION CODE OVERALL
10.	ERROR CODE			CODE INDICATING, WHY A TRANSACTION WASN'T PROCESSED
11.	PROCESSING DATE			DATE, WHEN THE TRANSACTION WAS PROCESSED
12.	TRANSACTION NUMBER			UNIQUE IDENTIFIER OF TRANSACTION PROCESSED BY TRXN TAX ENGINE
13.	ZERO RATE INDICATOR			INDICATES, WHETHER THERE IS NO TAX ON THE TRANSACTION OR THE TRANSACTION IS ZERO-RATED
14.	ZERO RATE REASON			INDICATE, WHETHER A TRANSACTION IS ZERO-RATED
15.	TAXING LOCATION			LOCATION TO BE DETERMINED TO BE THE TAXING LOCATION (POO, POA, SHIP-FROM, SHIP-TO, INVOICE-TO,...)
16.	JURISDICTION APPLIED			JURISDICTION APPLIED FOR TAXATION
17.		CONTRY		
18.		TERRITORY		
19.		STATE		
20.		PROVINCE		
21.		COUNTY		
22.		CITY		
23.		POSTAL CODE		
24.	TAX TYPE			TYPE OF TAY DETERMINED
25.		CONTRY		
26.		TERRITORY		
27.		STATE		
28.		PROVINCE		

FIELD NO.	DATA ELEMENT	SUB DATA ELEMENT	TYPE	DESCRIPTION
29.		COUNTY		
30.		CITY		
31.		POSTAL CODE		
32.	TAX CERTIFICATE APPLIED			NUMBER OF CERTIFICATE APPLIED TO THIS TRANSACTION (US)
33.		COUNTRY		
34.		TERRITORY		
35.		STATE		
36.		PROVINCE		
37.		COUNTY		
38.		CITY		
39.		POSTAL CODE		
40.	EXEMPT REASON			INDICATOR FOR EXEMPT REASON
41.		COUNTRY		
42.		TERRITORY		
43.		STATE		
44.		PROVINCE		
45.		COUNTY		
46.		CITY		
47.		POSTAL CODE		
48.	CALCULATE TAX AMOUNT			TAX AMOUNT CALCULATE
49.		OVERALL		SUMMARY OF ALL DETAIL LEVELS
50.		COUNTRY		
51.		TERRITORY		
52.		STATE		
53.		PROVINCE		
54.		COUNTY		
55.		CITY		
56.		POSTAL CODE		
57.	TAX RATE APPLIED			TAX RATE USED FOR CALCULATION
58.		COUNTRY		
59.		TERRITORY		
60.		STATE		
61.		PROVINCE		
62.		COUNTY		
63.		CITY		
64.		POSTAL CODE		

16/19

FIELD NO.	DATA ELEMENT	SUB DATA ELEMENT	TYPE	DESCRIPTION
65.	LINE ITEM SUM			SUM OF ALL AMOUNT FOR THE LINE ITEM
66.	INVOICE SUM			GROSS AMOUNT OF INVOICE (INCLUDING TAX)
67.	BASIS AMOUNT			AMOUNT USED FOR TAX CALCULATION
68.		COUNTRY		
69.		TERRITORY		
70.		STATE		
71.		PROVINCE		
72.		COUNTY		
73.		CITY		
74.		POSTAL CODE		
75.	REPORT INDICATOR			INDICATES ONTO WHICH REPORT (INTRASTAT, RETURN, VIES) THIS TRANSACTION BELONGS
76.	TITLES			SPECIFIC SENTENCE, WHICH NEED TO APPEAR ON THE LEGAL DOCUMENTS LIKE INVOICE
77.	RECOVERABLE INDICATOR			INDICATES, WHETHER OR NOT TAX FOR THIS TRANSACTION IS RECOVERABLE
78.	ACCOUNTING REFERENCE			REFERENCE TO ACCOUNT TO WHICH THE TAX AMOUNTS SHOULD BE BOOKED
79.	EXTERNAL TAX REFERENCE			REFERENCE TO EXTERNAL TAX IDENTIFICATION NEEDED FOR FURTHER PROCESSING WITHIN THE CALLING APPLICATION (I.E. SAP TAX CODE)

PROCESSING ELEMENTS

FIELD NO.	DATA ELEMENT	SUB DATA ELEMENT	TYPE	DESCRIPTION
1.	LANGUAGE			IDENTIFIES LANGUAGE USED FOR THIS DOCUMENT
2.	CALCULATION MODE			MODE OF CALCULATION (BACK CALCULATION TAX AMOUNT ALREADY PASSED)
3.	AUDIT FILE INDICATOR			TRANSACTION SHOULD BE LOGGED (IS FINAL TRANSACTION)
4.	EXEMPTION SYSTEM USE			INDICATES THAT EXEMPTION INFORMATION HAS TO BE RETRIEVED FROM A SPECIFIC EXEMPTION DOCUMENT ENGINE
5.	EXEMPTION LEVEL			INDICATES, WHICH THE EXEMPTION SHOULD BE USED
6.	END OF INVOICE INDICATOR			INDICATE THE END OF THE DOCUMENT
7.	INVOICE SUMMARY INDICAT.			TRANSACTION IS INVOICE SUMMARY
8.	REVERSE CHARGE INDICATOR			INDICATES THE USE THE REVERSE CHARGE MECHANISM
9.	REPORT EXCLUSION INDICATOR			INDICATES, THAT THIS TRANSACTION SHOULD BE EXCLUDED FROM TO BE DEFINED REPORTING

FIG. 7

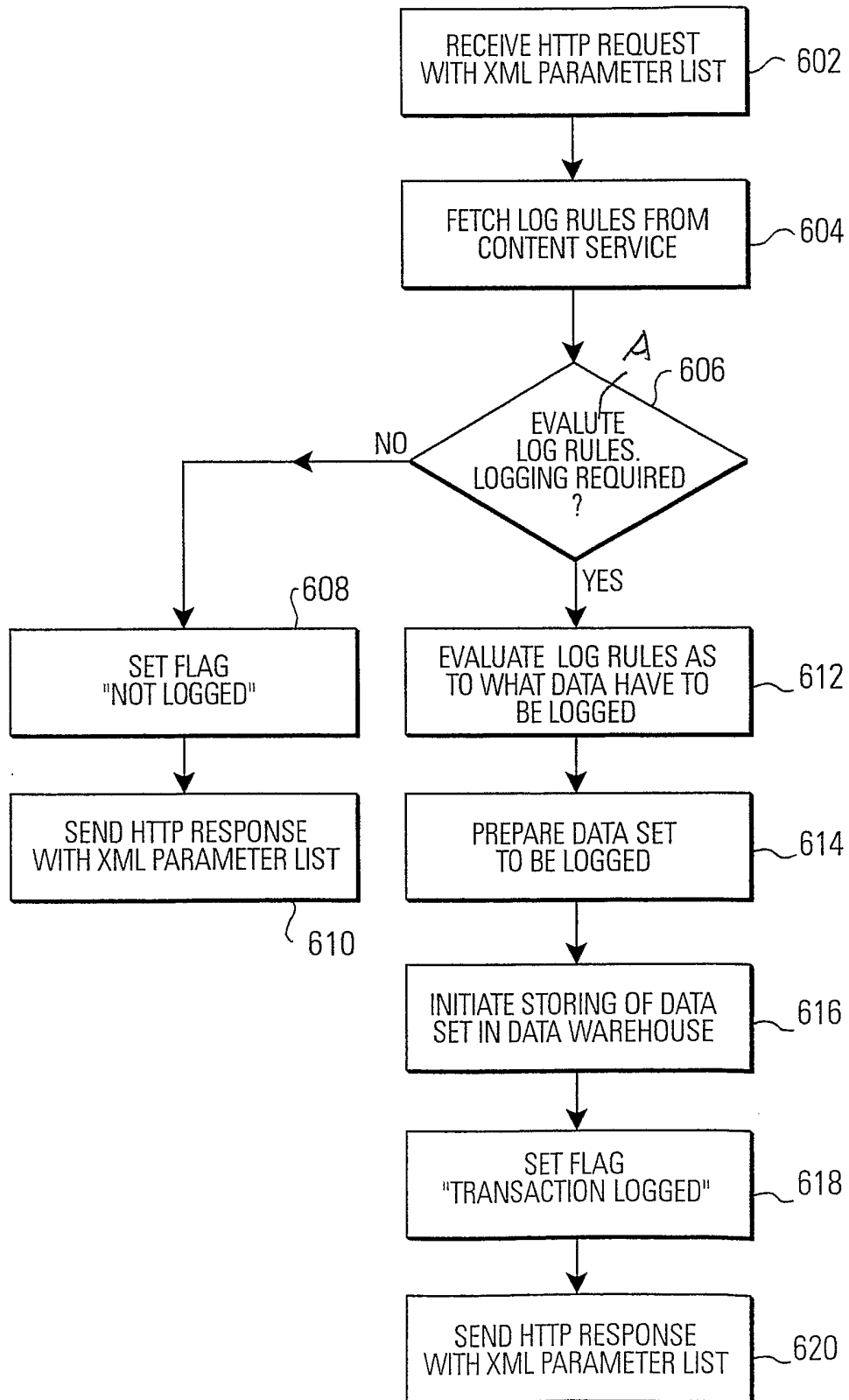

FIG. 8

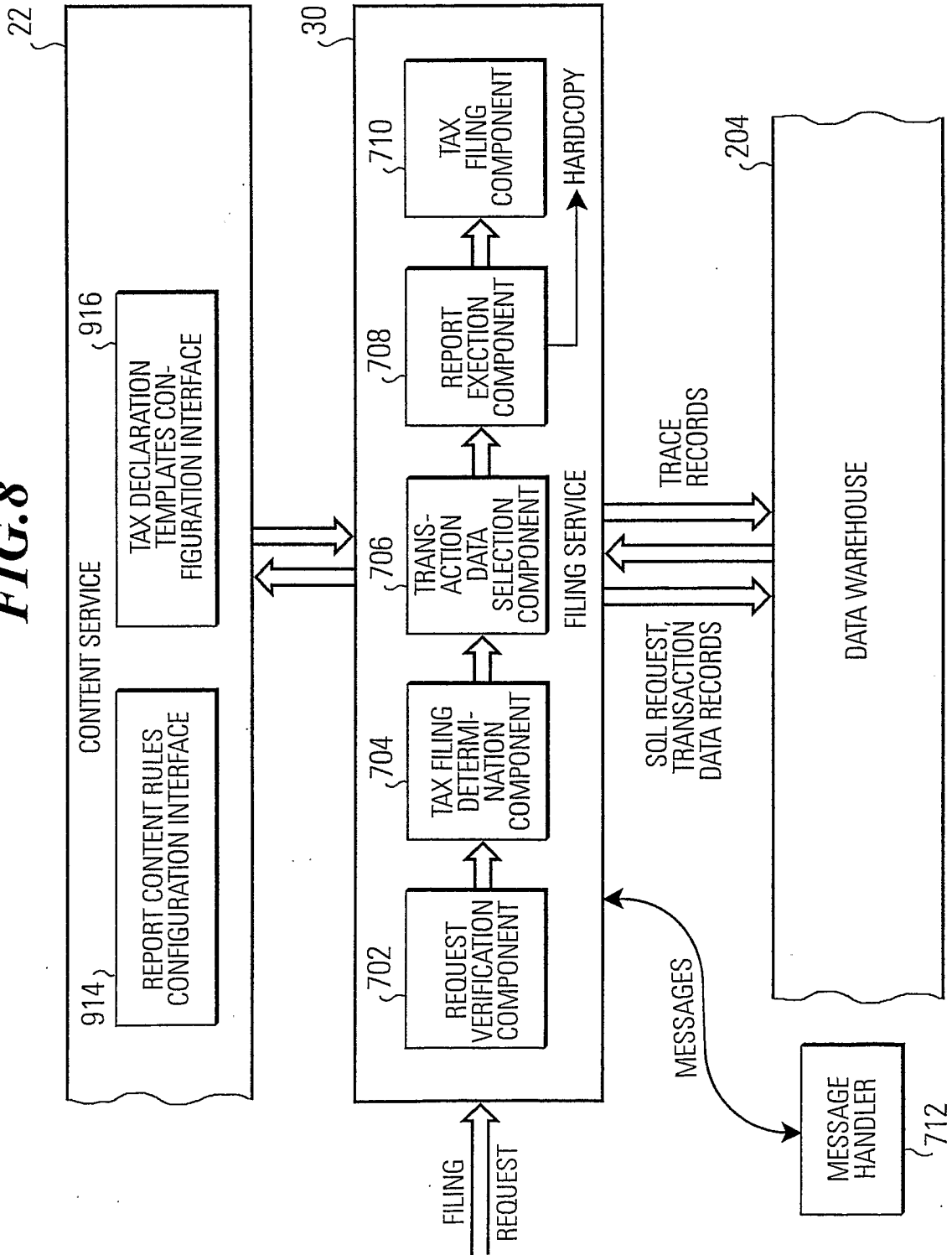
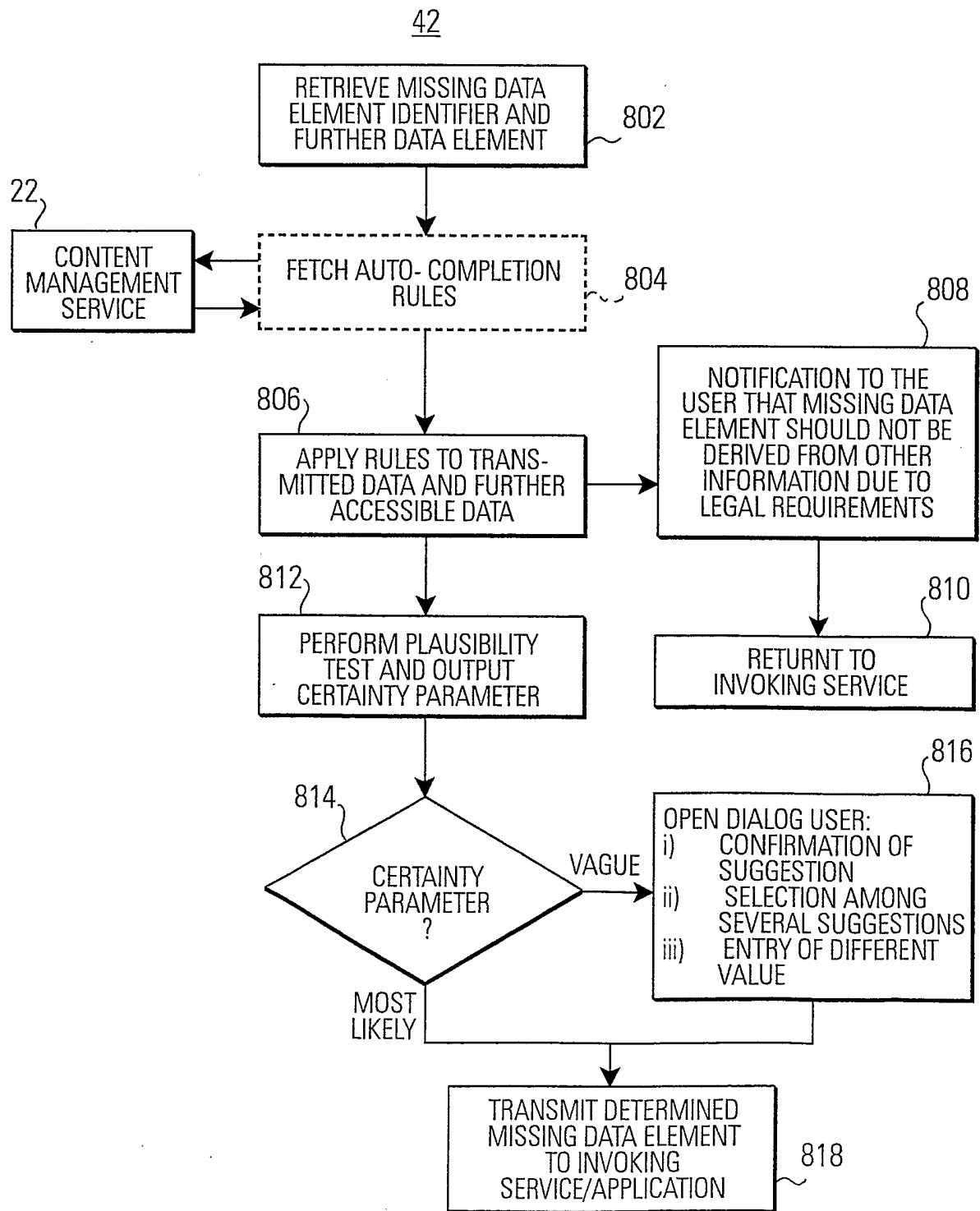

FIG. 9



INTERNATIONAL SEARCH REPORT

International Application No

PCT/EP 01/13756

A. CLASSIFICATION OF SUBJECT MATTER
 IPC 7 G06F9/46 G06F17/60

According to International Patent Classification (IPC) or to both national classification and IPC

B. FIELDS SEARCHED

Minimum documentation searched (classification system followed by classification symbols)

IPC 7 G06F

Documentation searched other than minimum documentation to the extent that such documents are included in the fields searched

Electronic data base consulted during the international search (name of data base and, where practical, search terms used)

EPO-Internal, INSPEC

C. DOCUMENTS CONSIDERED TO BE RELEVANT

Category *	Citation of document, with indication, where appropriate, of the relevant passages	Relevant to claim No.
X	US 6 308 178 B1 (HOFFMAN ROBERT JOHN ET AL) 23 October 2001 (2001-10-23) the whole document ---	1-31
X	WO 99 56206 A (ADC TELECOMMUNICATIONS INC) 4 November 1999 (1999-11-04) the whole document ---	1-31
X	WO 01 63455 A (LOPEZ LOPEZ ANTHONY ; SMARTENERGY COM INC (US); MOORE DOUGLAS (US);) 30 August 2001 (2001-08-30) the whole document ---	1-31
X	EP 1 016 989 A (SAGA SYSTEMS INC) 5 July 2000 (2000-07-05) the whole document ---	1-31
	-/--	

Further documents are listed in the continuation of box C.

Patent family members are listed in annex.

* Special categories of cited documents :

- *A* document defining the general state of the art which is not considered to be of particular relevance
- *E* earlier document but published on or after the international filing date
- *L* document which may throw doubts on priority claim(s) or which is cited to establish the publication date of another citation or other special reason (as specified)
- *O* document referring to an oral disclosure, use, exhibition or other means
- *P* document published prior to the international filing date but later than the priority date claimed

- *T* later document published after the international filing date or priority date and not in conflict with the application but cited to understand the principle or theory underlying the invention
- *X* document of particular relevance; the claimed invention cannot be considered novel or cannot be considered to involve an inventive step when the document is taken alone
- *Y* document of particular relevance; the claimed invention cannot be considered to involve an inventive step when the document is combined with one or more other such documents, such combination being obvious to a person skilled in the art.
- *Z* document member of the same patent family

Date of the actual completion of the international search

1 August 2002

Date of mailing of the international search report

16/08/2002

Name and mailing address of the ISA

European Patent Office, P.B. 5818 Patentlaan 2
 NL - 2280 HV Rijswijk
 Tel. (+31-70) 340-2040, Tx. 31 651 epo nl,
 Fax: (+31-70) 340-3016

Authorized officer

Sanandrés Ledesma, J

INTERNATIONAL SEARCH REPORT

International Application No

PCT/EP 01/13756

C.(Continuation) DOCUMENTS CONSIDERED TO BE RELEVANT		
Category °	Citation of document, with indication, where appropriate, of the relevant passages	Relevant to claim No.
X	<p>ARALD J-C AND SUHAS D J: "Architectural Choices for OSS Integration" EAI JOURNAL, 'Online! September 2001 (2001-09), pages 59-63, XP002201583 Retrieved from the Internet: <URL:http://www.eaijournal.com/PDF/OSSArchitecture.pdf> 'retrieved on 2002-06-07! the whole document</p> <p style="text-align: center;">---</p>	1-31
X	<p>WO 01 41552 A (SULLIVAN DANIEL L ;TAXWARE INTERNATIONAL INC (US)) 14 June 2001 (2001-06-14) the whole document</p> <p style="text-align: center;">---</p>	1-31
X	<p>"TaxBay Architecture Guide. Version 3.0" SABRIX, INC., 'Online! 25 July 2001 (2001-07-25), XP002201143 Retrieved from the Internet: <URL:http://www.sabrix.com/TaxBayArchitecture.pdf> 'retrieved on 2002-05-31! the whole document</p> <p style="text-align: center;">---</p>	1-31
X	<p>"Data Warehousing on HP 3000 Using IMAGE/SQL - A New Alternative" WHITE PAPER. HEWLETT-PACKARD COMPANY, 'Online! 1999, XP002204503 Retrieved from the Internet: <URL:http://www.hp.com/products1/mpeixservers/info_library/software/59683829.pdf> 'retrieved on 2002-07-03! the whole document</p> <p style="text-align: center;">---</p>	1-31
X	<p>GUPTA V R: "An Introduction to Data Warehousing" WHITE PAPER. SYSTEM SERVICES CORPORATION, 'Online! August 1997 (1997-08), XP002204504 Retrieved from the Internet: <URL:http://www.system-services.com/ftp/dwintro.doc> 'retrieved on 2002-07-03! the whole document</p> <p style="text-align: center;">---</p>	1-31
A	<p>GRAUPNER S ET AL: "E-Speak - an XML document interchange engine" ELECTRONIC COMMERCE AND WEB TECHNOLOGIES. SECOND INTERNATIONAL CONFERENCE, EC-WEB 2001. PROCEEDINGS , MUNICH, GERMANY, 4-6 SEPT. 2001(LECTURE NOTES IN COMPUTER SCIENCE VOL.2115), 2001, pages 270-279, XP002200341 Berlin, Germany, Springer-Verlag, Germany ISBN: 3-540-42517-9 the whole document</p> <p style="text-align: center;">---</p>	1-31

-/--

INTERNATIONAL SEARCH REPORT

International Application No
PCT/EP 01/13756

C.(Continuation) DOCUMENTS CONSIDERED TO BE RELEVANT		
Category °	Citation of document, with indication, where appropriate, of the relevant passages	Relevant to claim No.
A	<p>KA0 J: "Developer's Guide to Building XML-based Web Services with the Java 2 Platform, Enterprise Edition (J2EE)" THE MIDDLEWARE COMPANY, 'Online! June 2001 (2001-06), XP002201144 Retrieved from the Internet: <URL:http://www.theserverside.com/resources/pdf/J2EE-WebServices-DevGuide.pdf> 'retrieved on 2002-05-31! the whole document -----</p>	1-31

INTERNATIONAL SEARCH REPORT

Information on patent family members

International Application No

PCT/EP 01/13756

Patent document cited in search report		Publication date	Patent family member(s)	Publication date
US 6308178	B1	23-10-2001	AU 2468101 A WO 0129711 A1	30-04-2001 26-04-2001
WO 9956206	A	04-11-1999	US 6208345 B1 AU 3562699 A CA 2328325 A1 CN 1302401 T EP 1071992 A1 WO 9956206 A1	27-03-2001 16-11-1999 04-11-1999 04-07-2001 31-01-2001 04-11-1999
WO 0163455	A	30-08-2001	US 2001032197 A1 AU 4164801 A WO 0163455 A2	18-10-2001 03-09-2001 30-08-2001
EP 1016989	A	05-07-2000	US 6256676 B1 AU 1731100 A BR 9907032 A CA 2318203 A1 CN 1294710 T EP 1016989 A2 HU 0102564 A2 NO 20003652 A PL 343772 A1 TR 200002083 T1 WO 0029924 A2	03-07-2001 05-06-2000 16-01-2001 25-05-2000 09-05-2001 05-07-2000 28-11-2001 15-09-2000 10-09-2001 21-02-2001 25-05-2000
WO 0141552	A	14-06-2001	AU 4514301 A WO 0141552 A2	18-06-2001 14-06-2001