



US0D1029320S

(12) **United States Design Patent**
Wang

(10) **Patent No.:** **US D1,029,320 S**

(45) **Date of Patent:** **** May 28, 2024**

- (54) **VEHICLE TAILLAMP**
- (71) Applicant: **GM GLOBAL TECHNOLOGY OPERATIONS LLC**, Detroit, MI (US)
- (72) Inventor: **Feng Wang**, Shanghai (CN)
- (73) Assignee: **GM GLOBAL TECHNOLOGY OPERATIONS LLC**, Detroit, MI (US)
- (**) Term: **15 Years**
- (21) Appl. No.: **29/851,021**
- (22) Filed: **Aug. 25, 2022**
- (51) **LOC (14) Cl.** **26-06**
- (52) **U.S. Cl.**
USPC **D26/28**
- (58) **Field of Classification Search**
USPC D26/28, 29, 30, 31, 32, 33, 34, 35, 36, D26/139, 60, 49
CPC F21W 2103/35; F21W 2103/40; F21W 2102/17; F21W 2102/30; F21W 2103/00; F21W 2103/55; F21W 2104/00; F21W 2107/17; F21W 2107/13; F21S 41/00; F21S 41/141; F21S 41/162; F21S 41/18; F21S 41/20; F21S 41/33; F21S 41/36; F21S 41/60; F21S 43/00; F21V 21/0885; F21L 4/027; B62J 6/02; B62J 6/022; B62J 6/026
See application file for complete search history.

D683,871 S	6/2013	Munson et al.
D683,872 S	6/2013	Munson et al.
D686,359 S	7/2013	McCabe et al.
D686,360 S	7/2013	Davis
D686,767 S	7/2013	Davis
D686,774 S	7/2013	McCabe et al.
D692,598 S	10/2013	Davis
D694,439 S	11/2013	Davis
D694,443 S	11/2013	Mackay
D694,921 S	12/2013	Mackay
D703,847 S	4/2014	MacKay
D731,098 S	6/2015	Thole et al.
D731,099 S	6/2015	Thole et al.
D735,911 S	8/2015	O'Donnell et al.
D735,919 S	8/2015	Duff et al.
D736,451 S	8/2015	Smith et al.
D736,971 S	8/2015	Duff et al.
D737,481 S	8/2015	Thole et al.
D744,158 S	11/2015	Willett et al.
D745,712 S	12/2015	O'Donnell et al.

(Continued)

Primary Examiner — Angela J Lee

(57) **CLAIM**

The ornamental design for a vehicle taillamp, as shown and described.

DESCRIPTION

FIG. 1 is a front and left side perspective view of a vehicle taillamp showing my new design;
 FIG. 2 is a front elevation view of the vehicle taillamp of FIG. 1;
 FIG. 3 is a left side elevation view thereof;
 FIG. 4 is a right side elevation view thereof;
 FIG. 5 is a back elevation view thereof;
 FIG. 6 is a top plan view thereof; and,
 FIG. 7 is a bottom plan view thereof.
 The broken lines in the drawing depict portions of the vehicle taillamp that form no part of the claimed design. A mirror image of the vehicle taillamp is claimed as a second embodiment, but not shown in the drawings.

1 Claim, 7 Drawing Sheets

- (56) **References Cited**
U.S. PATENT DOCUMENTS
- | | | |
|------------|---------|---------------|
| D644,773 S | 9/2011 | Karras et al. |
| D655,837 S | 3/2012 | Karras et al. |
| D661,830 S | 6/2012 | de Queiroz |
| D670,840 S | 11/2012 | McCabe et al. |
| D670,841 S | 11/2012 | Duff et al. |
| D683,869 S | 6/2013 | Schmeckpeper |
| D683,870 S | 6/2013 | Schmeckpeper |

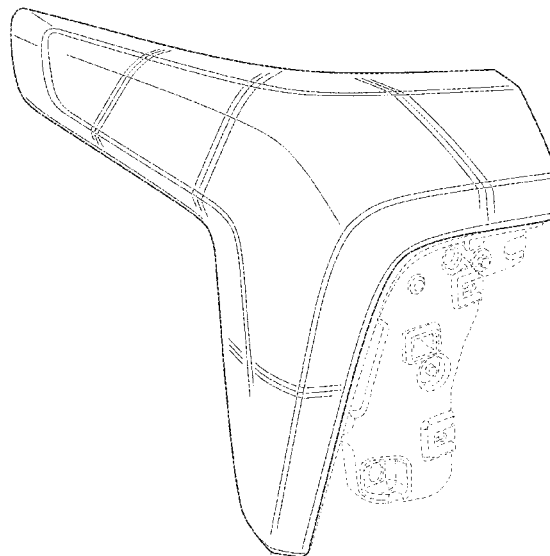

(56)

References Cited

U.S. PATENT DOCUMENTS

D745,719 S	12/2015	Boniface et al.	D844,184 S	3/2019	Whitla et al.
D745,725 S	12/2015	McMahan et al.	D844,185 S	3/2019	Hochmuth
D745,726 S	12/2015	McMahan et al.	D844,186 S	3/2019	Smith et al.
D746,496 S	12/2015	Loeb	D845,518 S	4/2019	Kozub
D747,514 S	1/2016	McMahan et al.	D845,519 S	4/2019	Zipfel
D747,515 S	1/2016	McMahan et al.	D846,769 S	4/2019	Koo et al.
D747,819 S	1/2016	Thole et al.	D846,770 S	4/2019	Kozub
D749,246 S	2/2016	Thole et al.	D846,771 S	4/2019	Zipfel
D749,249 S	2/2016	Thole et al.	D846,772 S	4/2019	Pinazzo et al.
D749,250 S	2/2016	Thole et al.	D847,390 S	4/2019	Koo et al.
D752,253 S	3/2016	Loeb	D847,391 S	4/2019	Pinazzo et al.
D765,284 S	8/2016	Kim et al.	D847,392 S	4/2019	Zipfel
D765,893 S	9/2016	Kim et al.	D848,647 S	5/2019	Kozub
D770,068 S	10/2016	Kapitonov	D852,389 S	6/2019	Koo et al.
D773,084 S	11/2016	Kapitonov	D852,393 S	6/2019	Whitla et al.
D773,086 S	11/2016	McCabe et al.	D852,998 S	* 7/2019	Takahashi D26/28
D774,226 S	12/2016	McCabe et al.	D857,260 S	8/2019	Kil et al.
D776,310 S	1/2017	Mackay	D857,936 S	8/2019	Kil et al.
D776,841 S	1/2017	Kozub et al.	D857,938 S	8/2019	Blanski et al.
D776,843 S	1/2017	McCabe et al.	D857,939 S	8/2019	Kozub
D776,846 S	1/2017	Willett et al.	D857,940 S	8/2019	Park
D777,359 S	1/2017	Kozub et al.	D857,941 S	8/2019	Whitla et al.
D777,360 S	1/2017	Kozub et al.	D857,942 S	8/2019	Perkins
D777,361 S	1/2017	Kozub et al.	D857,943 S	8/2019	Hochmuth
D777,955 S	1/2017	Willett et al.	D857,944 S	8/2019	Pinazzo et al.
D784,579 S	4/2017	Cheng et al.	D857,945 S	8/2019	Smith et al.
D789,575 S	6/2017	Willett	D857,946 S	8/2019	Smith et al.
D793,590 S	8/2017	Kozub et al.	D857,947 S	8/2019	Koo et al.
D793,591 S	8/2017	Kozub et al.	D857,948 S	8/2019	Koo et al.
D794,229 S	8/2017	Barry	D857,949 S	8/2019	Smith et al.
D794,230 S	8/2017	Kozub	D857,950 S	8/2019	Zipfel
D796,088 S	8/2017	McCabe et al.	D857,951 S	8/2019	Whitla et al.
D796,093 S	8/2017	Mainville	D857,952 S	8/2019	Smith et al.
D797,967 S	9/2017	Barry	D858,813 S	9/2019	Datta
D797,970 S	9/2017	Mainville	D858,814 S	9/2019	Burns
D797,971 S	9/2017	Mainville	D858,817 S	9/2019	Henriques
D797,972 S	9/2017	Whitla et al.	D858,818 S	9/2019	McMahan et al.
D799,728 S	10/2017	Whitla et al.	D858,819 S	9/2019	McMahan et al.
D801,577 S	10/2017	Ruiz	D858,820 S	9/2019	McMahan et al.
D806,284 S	* 12/2017	Yamaguchi D26/28	D858,821 S	9/2019	Park
D818,156 S	5/2018	Kim et al.	D858,822 S	9/2019	Whitla et al.
D818,157 S	5/2018	Zipfel et al.	D858,823 S	9/2019	Zipfel
D818,158 S	5/2018	Zipfel et al.	D858,824 S	9/2019	Pinazzo et al.
D818,159 S	5/2018	Zipfel et al.	D859,707 S	9/2019	McMahan et al.
D818,160 S	5/2018	Perkins	D859,708 S	9/2019	Kozub
D821,617 S	6/2018	Perkins	D859,709 S	9/2019	Zipfel
D825,083 S	8/2018	Perkins	D860,489 S	9/2019	Henriques
D826,435 S	8/2018	Kim	D860,490 S	9/2019	Henriques
D828,935 S	9/2018	Hochmuth	D862,750 S	* 10/2019	Sakai D26/28
D830,589 S	10/2018	Henriques	D863,625 S	10/2019	Kim
D833,040 S	11/2018	Henriques	D863,629 S	10/2019	Whitla et al.
D836,222 S	12/2018	Henriques	D863,630 S	10/2019	Whitla et al.
D836,223 S	12/2018	Kim	D863,662 S	10/2019	Yong et al.
D836,807 S	12/2018	Whitla et al.	D863,664 S	10/2019	Kozub
D837,424 S	1/2019	Whitla et al.	D864,441 S	10/2019	Perkins
D838,015 S	1/2019	McMahan et al.	D868,302 S	11/2019	Hochmuth
D838,016 S	1/2019	McMahan et al.	D868,357 S	11/2019	De Leon
D838,390 S	1/2019	McMahan et al.	D869,015 S	12/2019	Pinazzo et al.
D838,391 S	1/2019	McMahan et al.	D869,026 S	12/2019	Zipfel
D839,460 S	1/2019	Zipfel et al.	D869,027 S	12/2019	Zipfel
D840,068 S	2/2019	Zipfel et al.	D869,028 S	12/2019	Zipfel
D840,069 S	2/2019	Perkins	D874,029 S	1/2020	Mack et al.
D840,565 S	2/2019	Whitla et al.	D874,030 S	1/2020	Mack et al.
D840,570 S	2/2019	Kim et al.	D874,033 S	1/2020	Park Cheng et al.
D840,571 S	2/2019	Zipfel et al.	D874,034 S	1/2020	Schmeckpeper
D840,572 S	2/2019	Perkins	D874,035 S	1/2020	Park Cheng et al.
D841,843 S	2/2019	Park	D874,053 S	1/2020	Zipfel
D841,844 S	2/2019	Perkins	D874,693 S	2/2020	Blanski et al.
D841,845 S	2/2019	Park	D874,697 S	2/2020	Schmeckpeper
D843,023 S	3/2019	Whitla et al.	D875,281 S	2/2020	Schmeckpeper
D843,024 S	3/2019	Hochmuth	D876,690 S	2/2020	Schmeckpeper
D843,025 S	3/2019	Smith et al.	D877,369 S	3/2020	Thurber et al.
D843,614 S	3/2019	Whitla et al.	D877,376 S	3/2020	Cheng et al.
D843,616 S	3/2019	Smith et al.	D877,377 S	3/2020	Cheng et al.
D843,617 S	3/2019	Smith et al.	D877,941 S	3/2020	Thurber et al.
			D884,939 S	5/2020	Kozub
			D885,618 S	5/2020	Mack et al.
			D887,591 S	6/2020	Mack et al.
			D887,596 S	6/2020	Pinazzo et al.

(56)

References Cited

U.S. PATENT DOCUMENTS

D891,656 S	*	7/2020	Kim	D26/28	D950,783 S	5/2022	Davis	
D894,438 S		8/2020	Park Cheng et al.		D950,784 S	5/2022	Davis	
D894,439 S		8/2020	Izard		D950,785 S	5/2022	Datta	
D894,440 S		8/2020	Koo et al.		D950,786 S	5/2022	Datta	
D894,441 S		8/2020	Koo et al.		D950,787 S	5/2022	Datta	
D895,859 S		9/2020	Izard		D950,788 S	5/2022	Zhao et al.	
D897,013 S		9/2020	Cheng et al.		D950,790 S	5/2022	Datta	
D903,159 S		11/2020	Zipfel		D950,791 S	5/2022	Datta	
D903,160 S		11/2020	Zipfel		D950,792 S	5/2022	Davis	
D903,161 S		11/2020	Zipfel		D950,793 S	5/2022	Davis	
D903,163 S		11/2020	Choi et al.		D950,794 S	5/2022	Theis et al.	
D903,164 S		11/2020	Choi et al.		D950,795 S	5/2022	Theis et al.	
D903,165 S		11/2020	Choi et al.		D950,796 S	5/2022	Davis	
D903,166 S		11/2020	Choi et al.		D950,797 S	5/2022	Theis et al.	
D903,167 S		11/2020	Choi et al.		D950,798 S	5/2022	Theis et al.	
D903,168 S		11/2020	Choi et al.		D950,799 S	5/2022	Theis et al.	
D913,536 S		3/2021	Koo et al.		D950,800 S	5/2022	Theis et al.	
D913,537 S		3/2021	Koo et al.		D950,806 S	5/2022	Barry et al.	
D919,136 S		5/2021	Park et al.		D950,807 S	5/2022	Jevremovic	
D919,857 S		5/2021	Park et al.		D950,808 S	5/2022	Jevremovic	
D919,858 S		5/2021	Park et al.		D950,809 S	5/2022	Jevremovic	
D919,859 S		5/2021	Park et al.		D950,810 S	5/2022	Chung	
D920,544 S		5/2021	Kim		D950,811 S	5/2022	Jevremovic	
D920,545 S		5/2021	Mack et al.		D950,812 S	5/2022	De Leon et al.	
D920,548 S		5/2021	Park et al.		D950,813 S	5/2022	De Leon et al.	
D920,549 S		5/2021	Park et al.		D950,814 S	5/2022	De Leon et al.	
D930,859 S		9/2021	Park et al.		D950,815 S	5/2022	De Leon et al.	
D930,860 S	*	9/2021	Hartenstein	D26/28	D952,213 S	*	5/2022	Shin D26/28
D933,266 S		10/2021	Park et al.		D961,129 S	*	8/2022	Buller D26/28
D939,115 S		12/2021	Chen et al.		D977,165 S	*	1/2023	Lin D26/28
D939,741 S		12/2021	Chen et al.		D985,811 S	*	5/2023	Polder D26/28
D945,031 S		3/2022	Chen et al.		D992,161 S	*	7/2023	Jie D26/28
					D1,001,326 S	*	10/2023	Seo D26/28
					D1,009,315 S	*	12/2023	Roller D26/28
					D1,010,177 S	*	1/2024	Seo D26/28

* cited by examiner

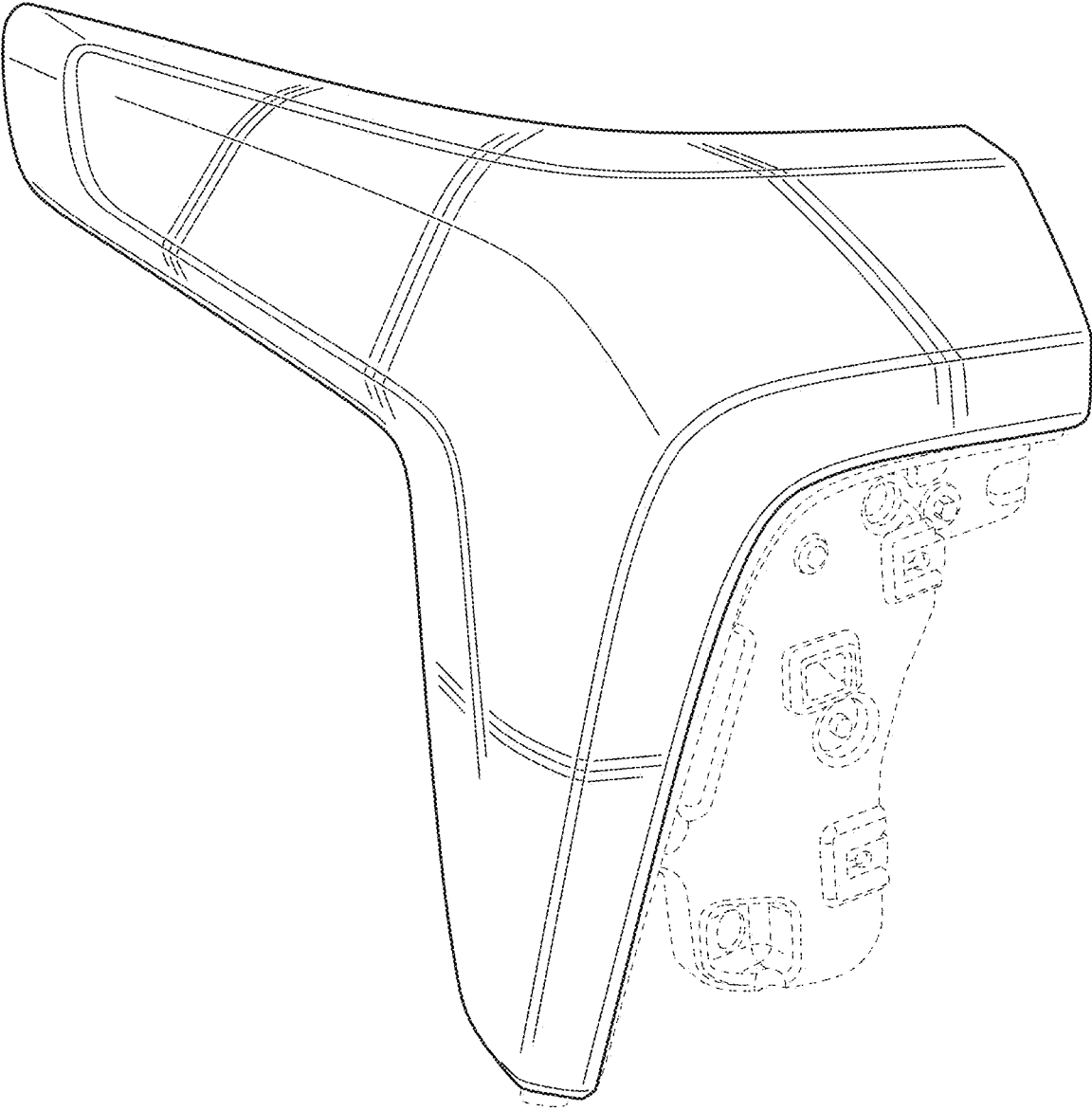

FIG. 1



FIG. 2

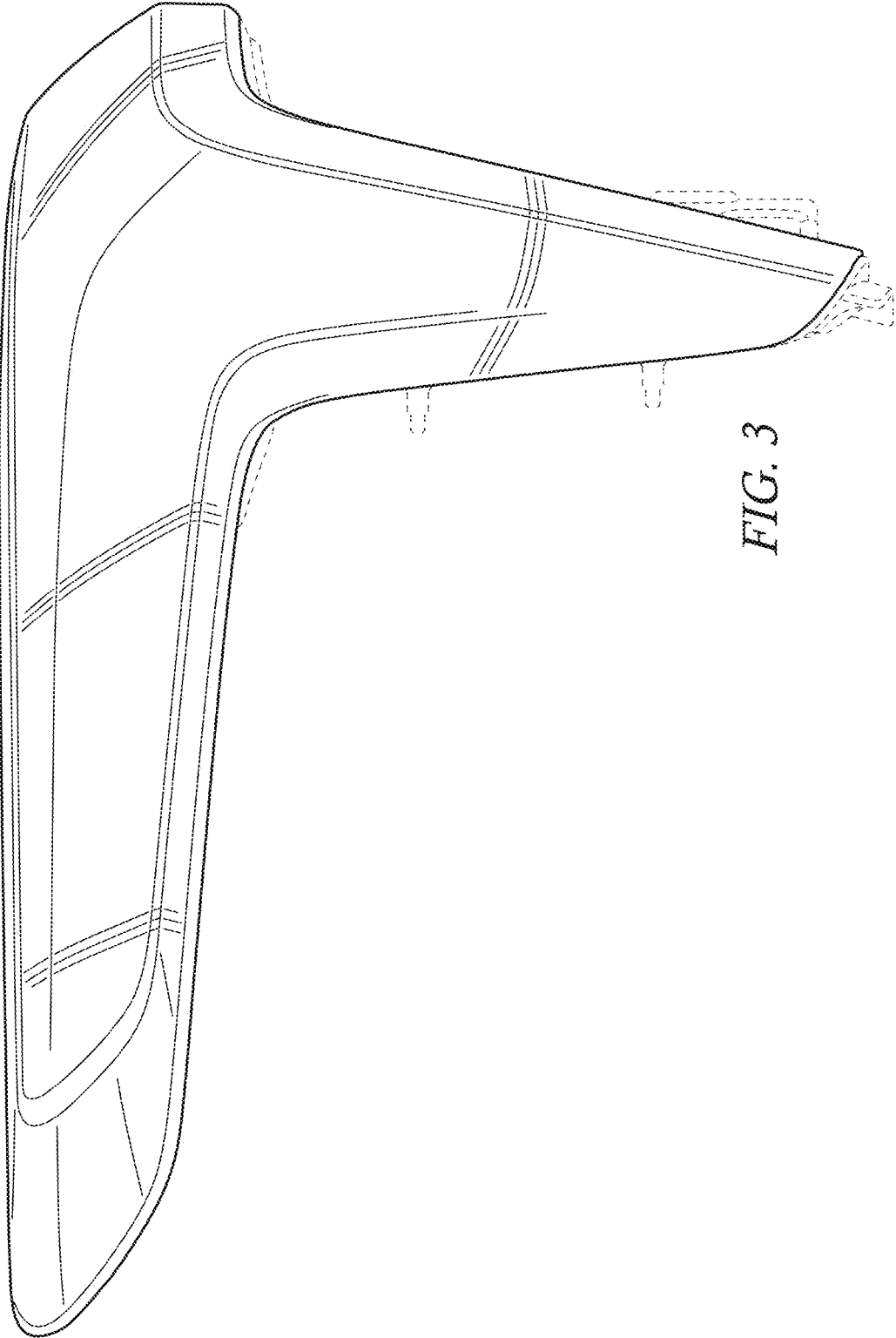

FIG. 3

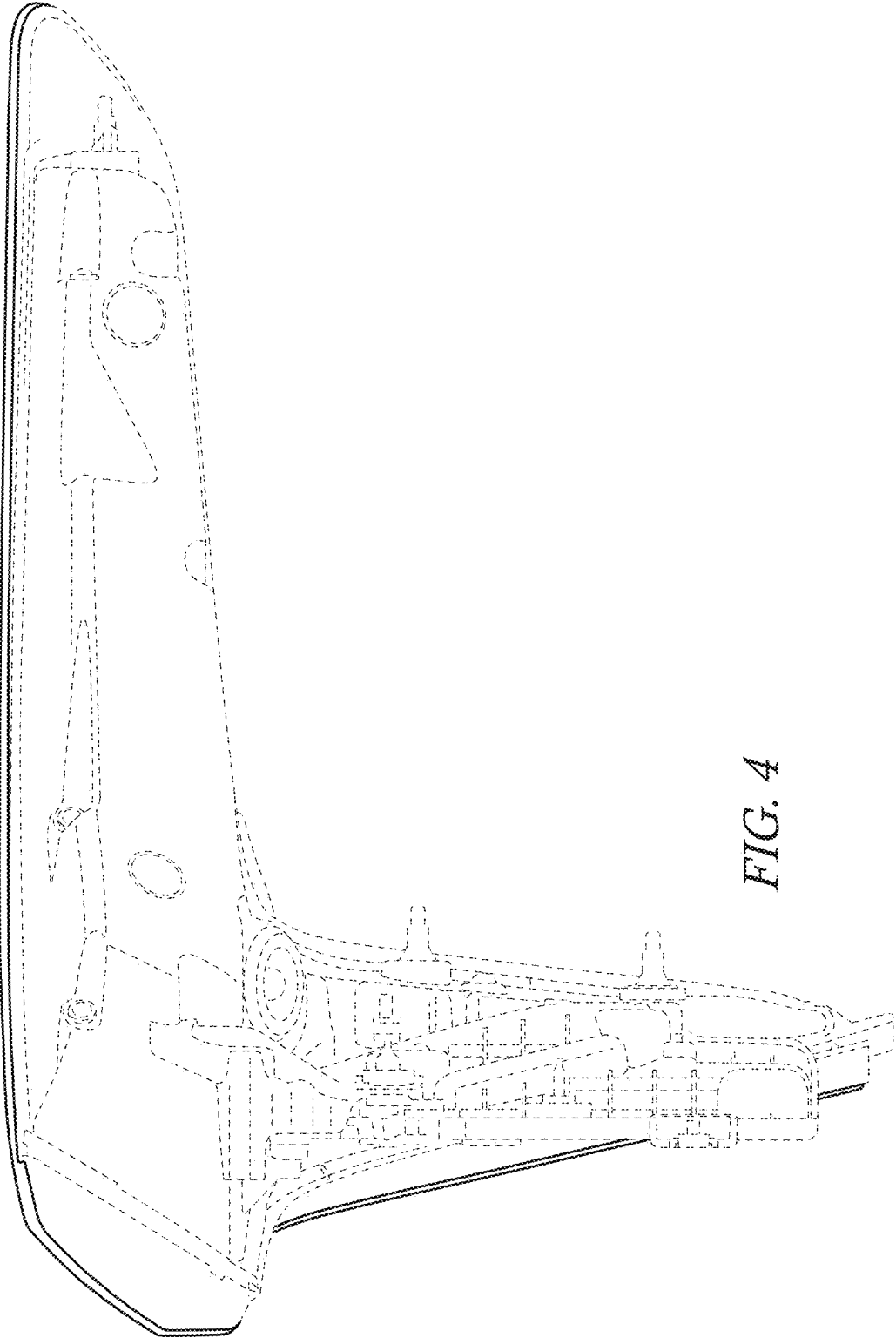

FIG. 4

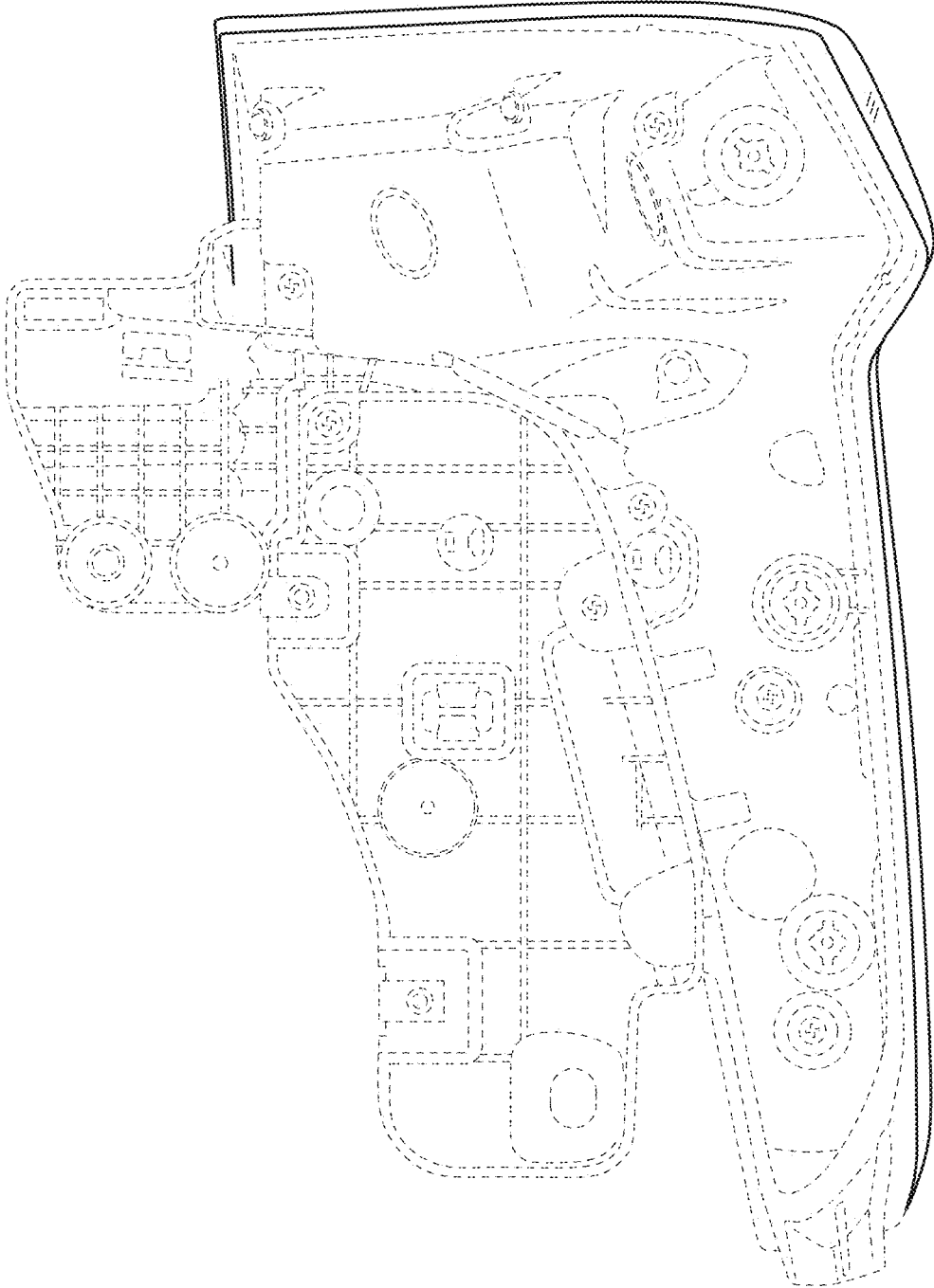

FIG. 5

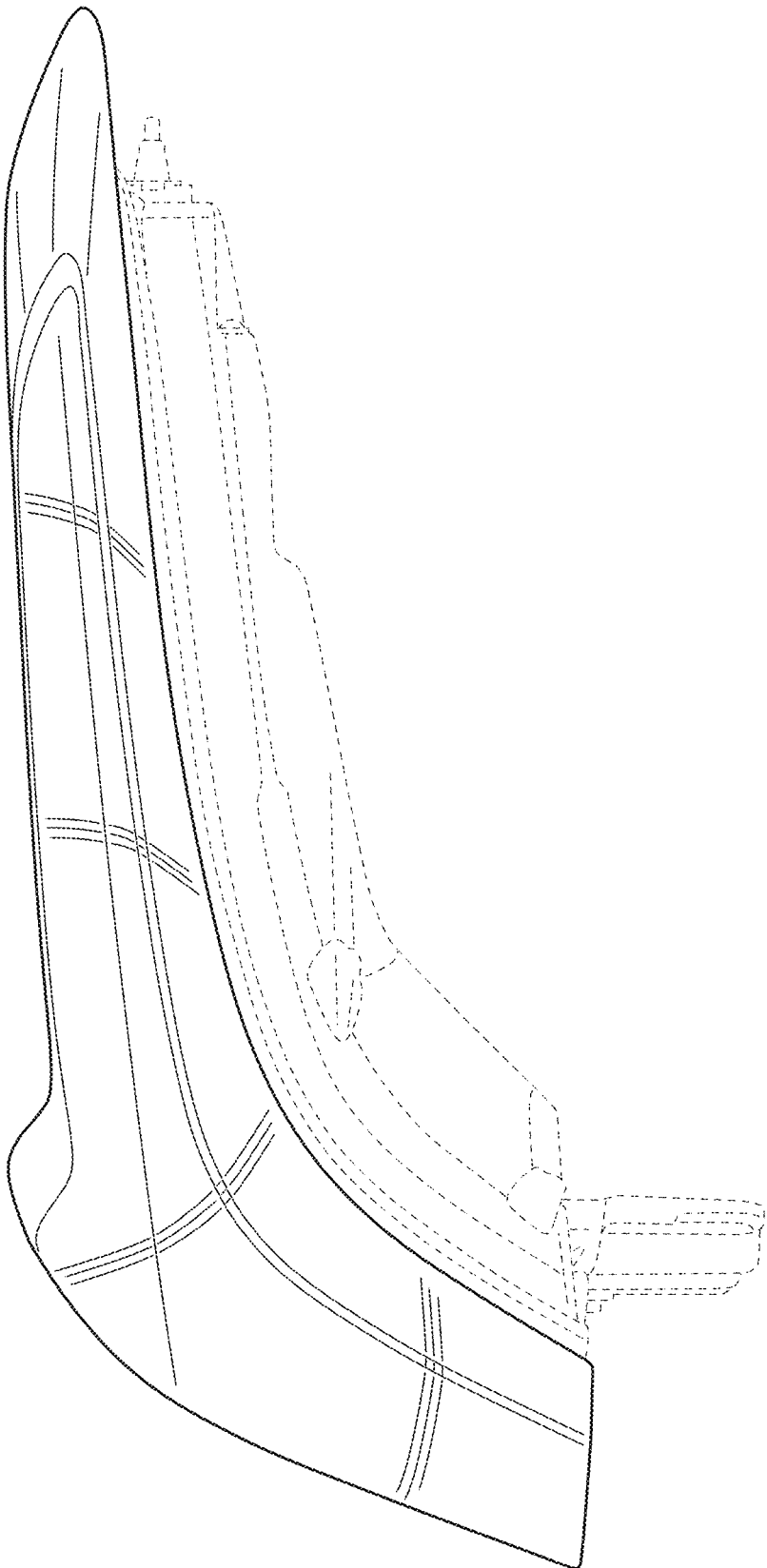

FIG. 6

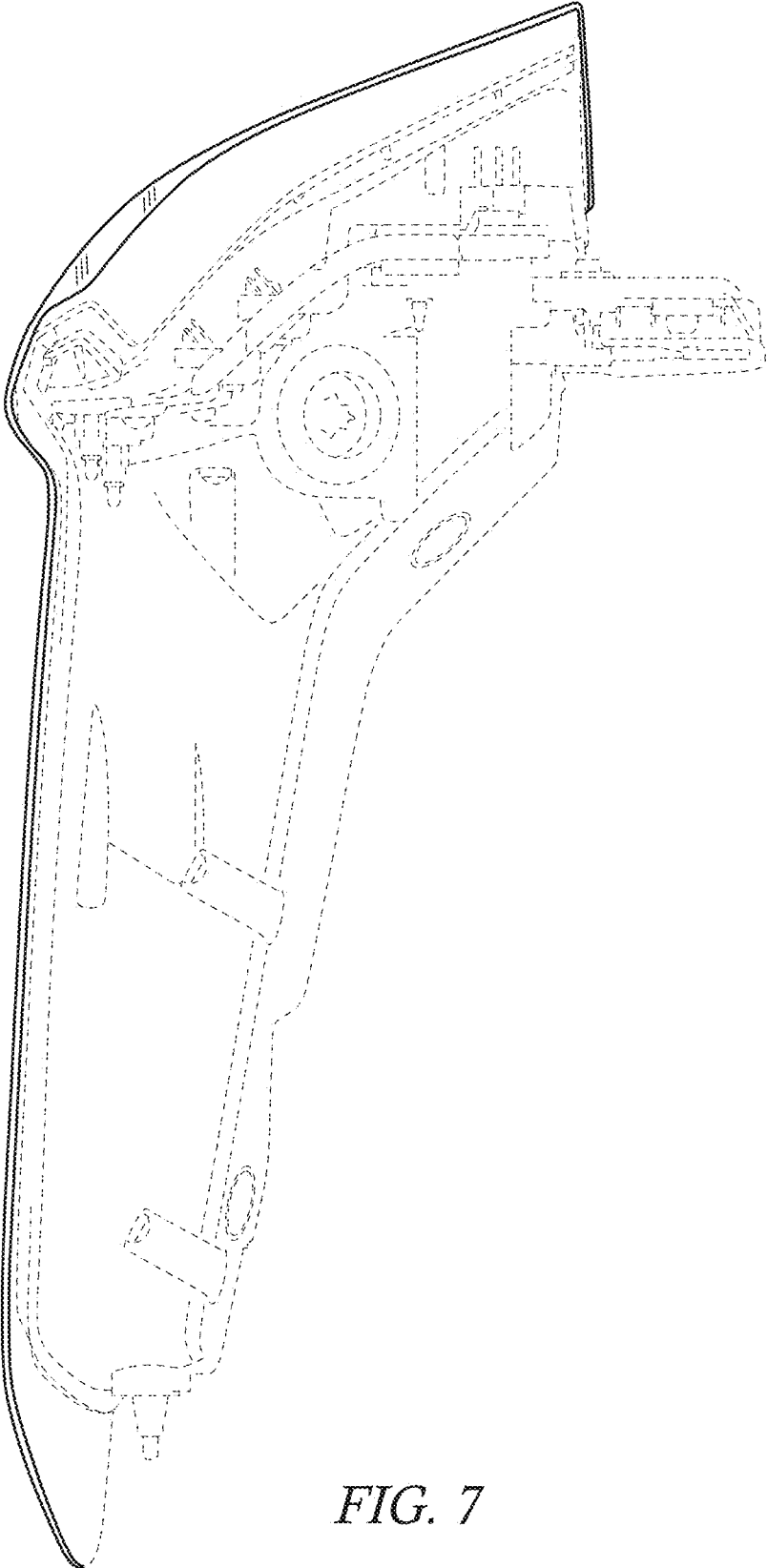

FIG. 7