



US 20170270973A9

(19) **United States**  
(12) **Patent Application Publication**  
**Barton et al.**

(10) **Pub. No.: US 2017/0270973 A9**  
(48) **Pub. Date: Sep. 21, 2017**  
**CORRECTED PUBLICATION**

(54) **MULTIPLE OUTLET DIGITAL VIDEO RECORDING SYSTEM**  
(71) Applicant: **TiVo Solutions Inc.**, San Carlos, CA (US)  
(72) Inventors: **James M. Barton**, Los Gatos, CA (US); **Roderick James McInnis**, Milpitas, CA (US); **Alan S. Moskowitz**, Oakland, CA (US); **Andrew Martin Goodman**, Portola Valley, CA (US); **Ching Tong Chow**, Los Altos, CA (US); **Jean Sway Kao**, Cupertino, CA (US)

*H04N 5/775* (2006.01)  
*H04N 5/781* (2006.01)  
*H04N 9/79* (2006.01)  
*G11B 27/00* (2006.01)  
*H04N 5/783* (2006.01)  
*H04N 21/4147* (2006.01)  
*H04N 21/426* (2006.01)  
*H04N 21/432* (2006.01)  
*H04N 21/433* (2006.01)  
*H04N 21/472* (2006.01)  
*H04N 21/845* (2006.01)  
*H04N 21/8547* (2006.01)  
*G11B 27/30* (2006.01)

(21) Appl. No.: **14/613,336**  
(22) Filed: **Feb. 3, 2015**

(52) **U.S. Cl.**  
CPC ..... *G11B 27/105* (2013.01); *G11B 27/3027* (2013.01); *H04N 5/4401* (2013.01); *H04N 5/76* (2013.01); *H04N 5/775* (2013.01); *H04N 5/781* (2013.01); *H04N 9/7921* (2013.01); *G11B 27/002* (2013.01); *H04N 5/783* (2013.01); *H04N 21/4147* (2013.01); *H04N 21/4263* (2013.01); *H04N 21/432* (2013.01); *H04N 21/4334* (2013.01); *H04N 21/472* (2013.01); *H04N 21/47214* (2013.01); *H04N 21/8456* (2013.01); *H04N 21/8547* (2013.01)

**Prior Publication Data**

(15) Correction of US 2015/0147044 A1 May 28, 2015 See (63) Related U.S. Application Data.  
(65) US 2015/0147044 A1 May 28, 2015

**Related U.S. Application Data**

(63) Continuation of application No. 14/017,165, filed on Sep. 3, 2013, now Pat. No. 8,948,569, which is a continuation of application No. 12/430,024, filed on Apr. 24, 2009, now Pat. No. 8,526,781, which is a continuation of application No. 10/081,776, filed on Feb. 20, 2002, now Pat. No. 7,529,465, which is a continuation of application No. 09/827,029, filed on Apr. 5, 2001, now abandoned, which is a continuation of application No. 09/126,071, filed on Jul. 30, 1998, now Pat. No. 6,233,389.

**Publication Classification**

(51) **Int. Cl.**  
*G11B 27/10* (2006.01)  
*H04N 5/44* (2006.01)  
*H04N 5/76* (2006.01)

(57) **ABSTRACT**

A multimedia time warping system allows a user to store selected multimedia data streams while the user is simultaneously watching or reviewing other multimedia data. Data streams are converted to digital streams for internal transfer and manipulation. A parser and event buffer decouple the CPU from having to parse the digital stream. Video segments are stored on a storage device and when data is requested for display, its video segments are extracted from the storage device and sent to a decoder that converts them into display output signals and delivers the display output signals to a display.

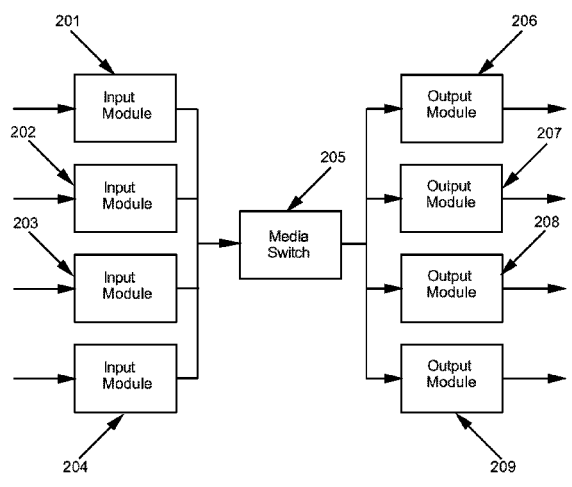

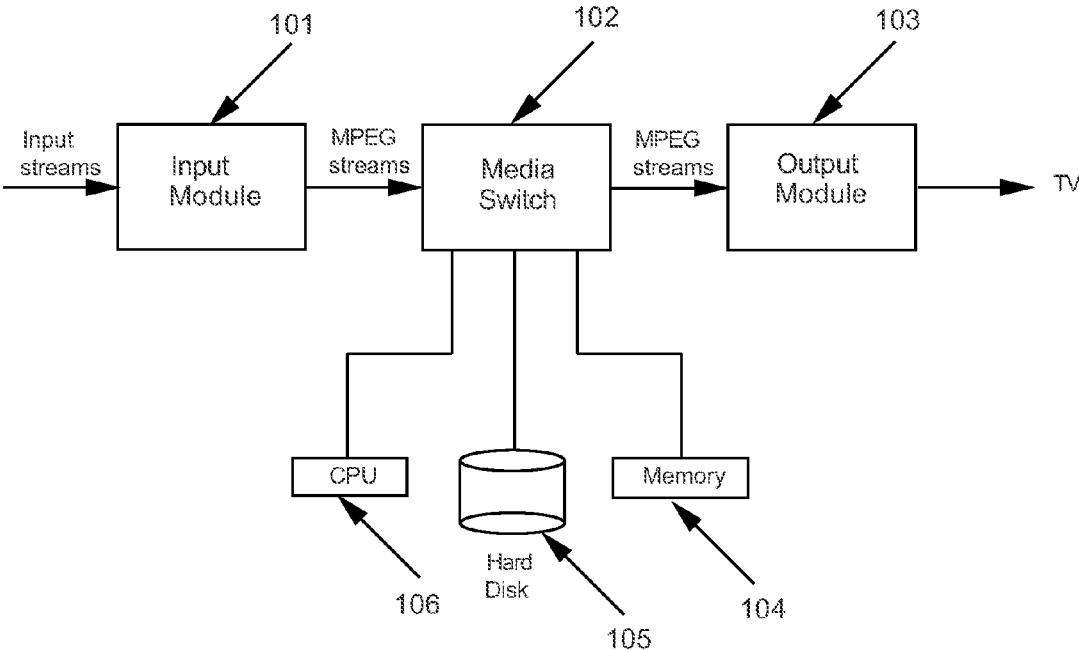

Fig. 1

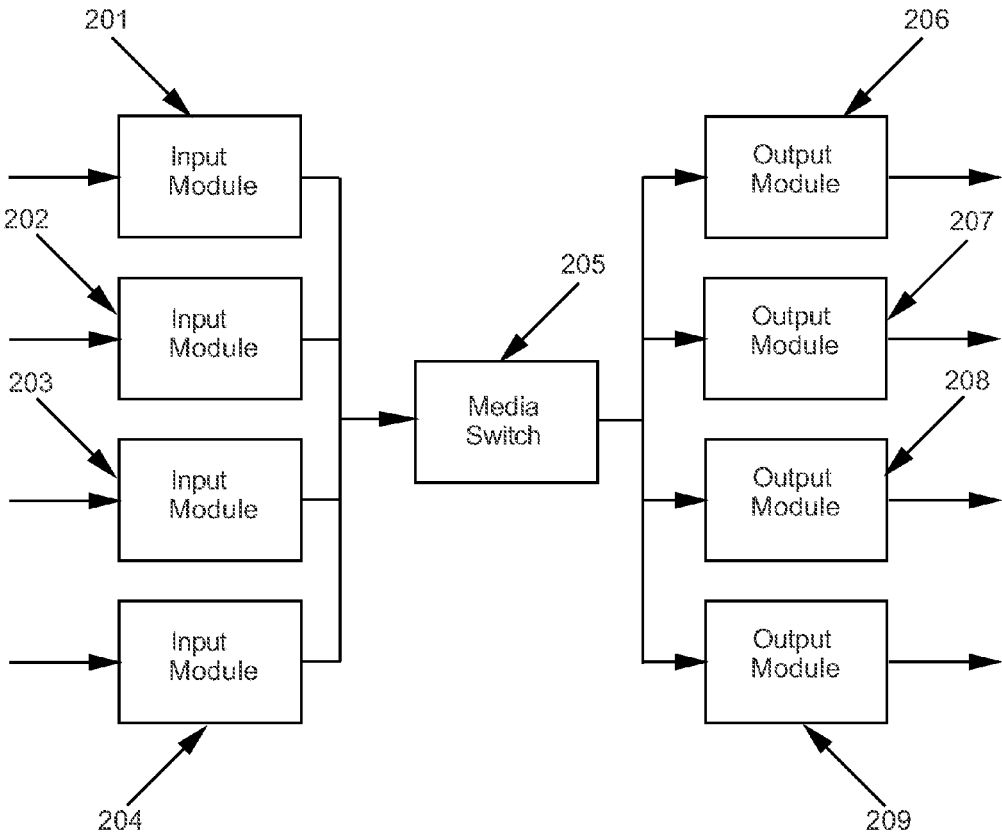

Fig. 2

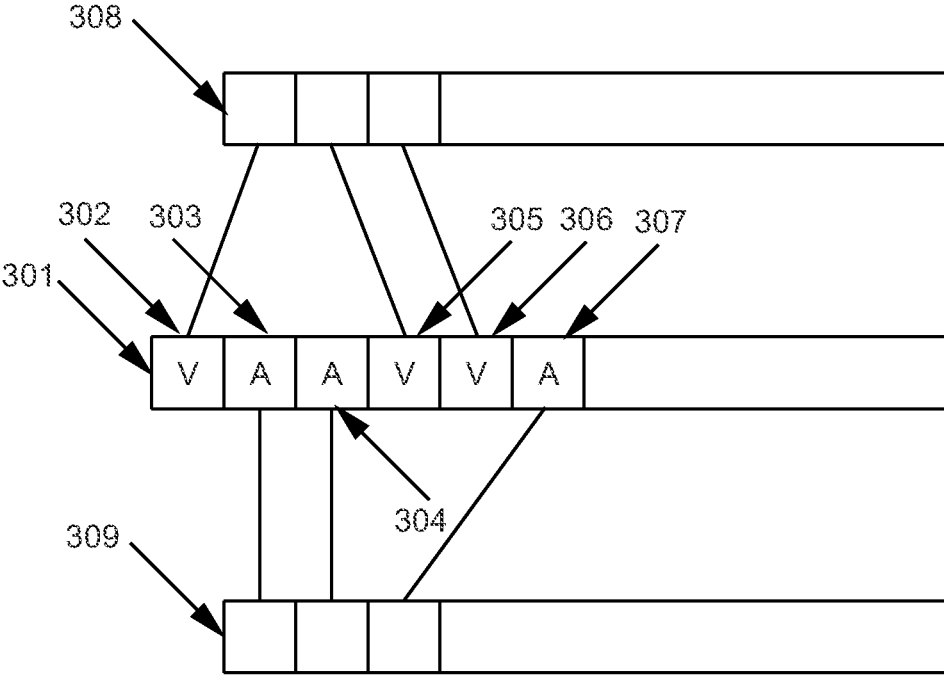

Fig. 3

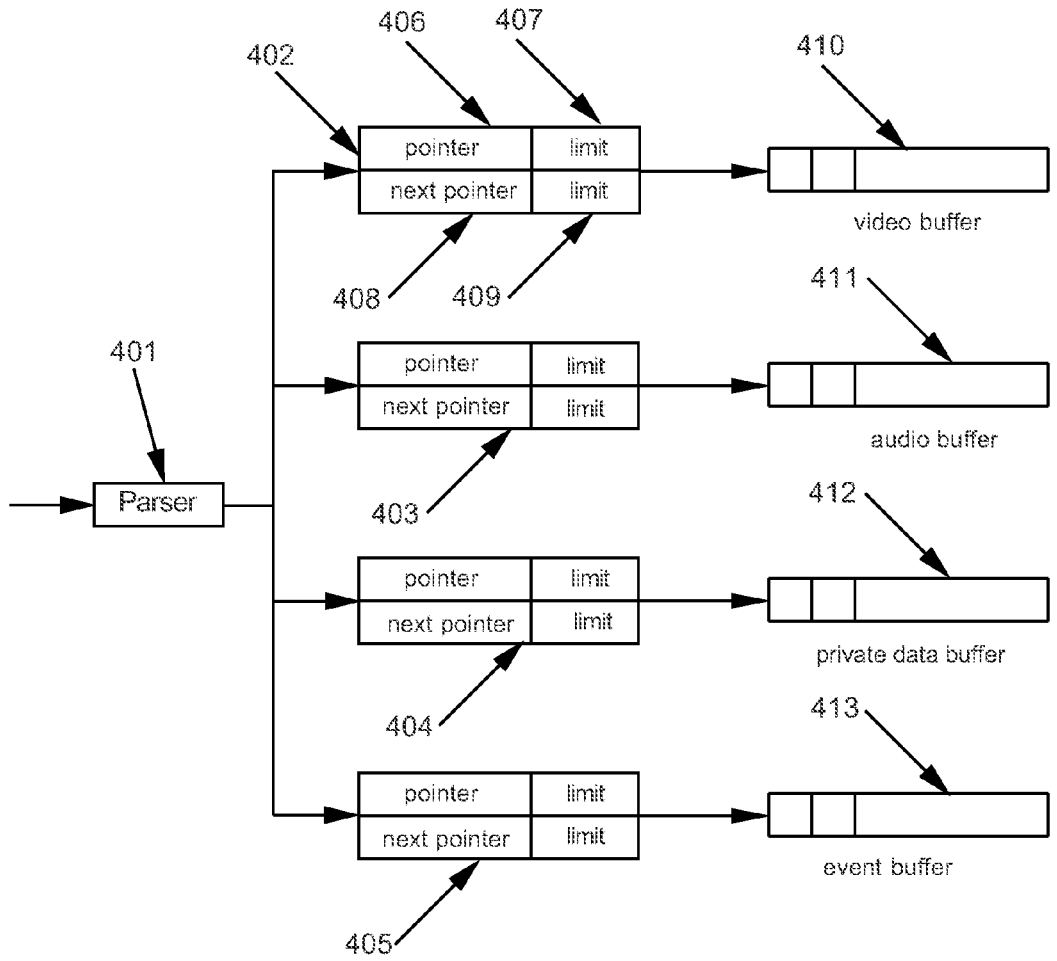

Fig. 4

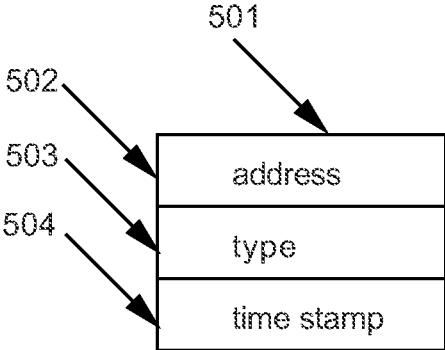

Fig. 5

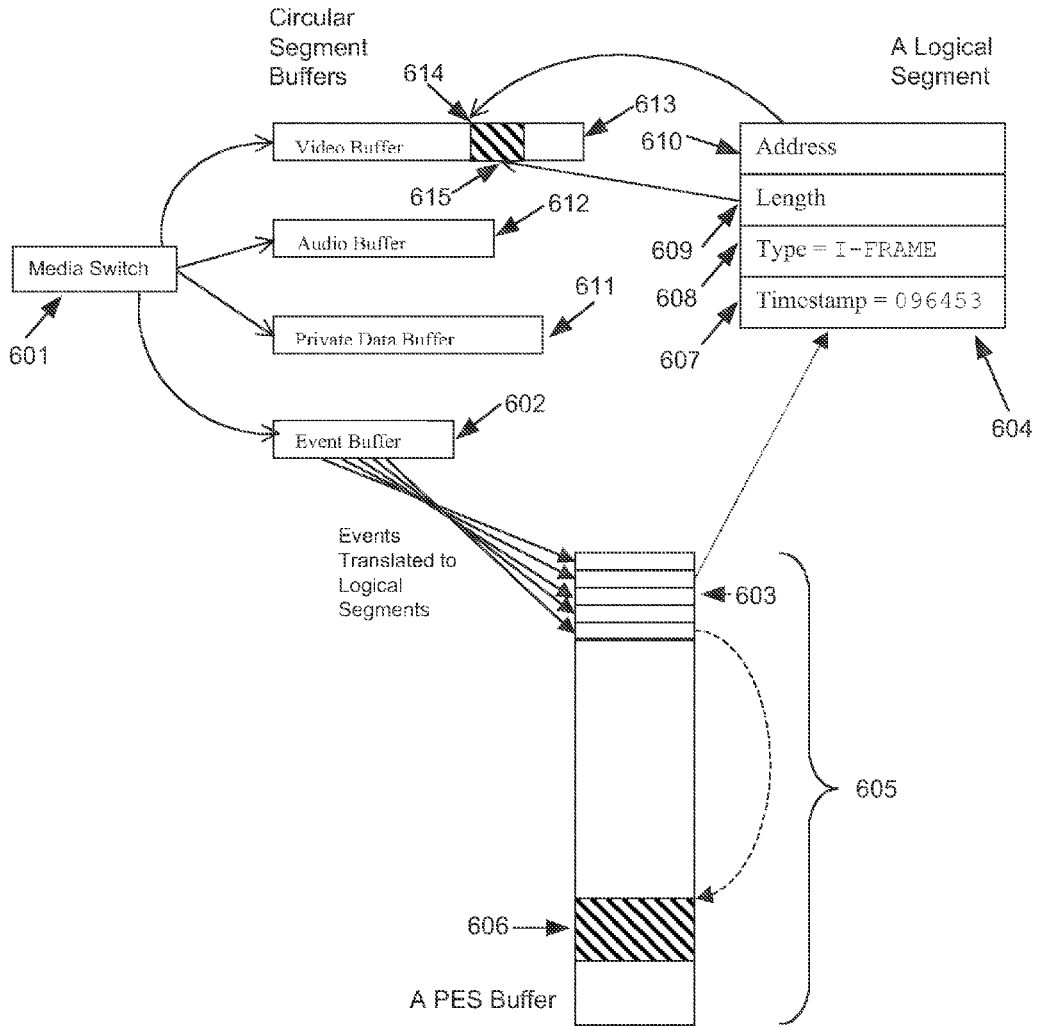

Fig. 6

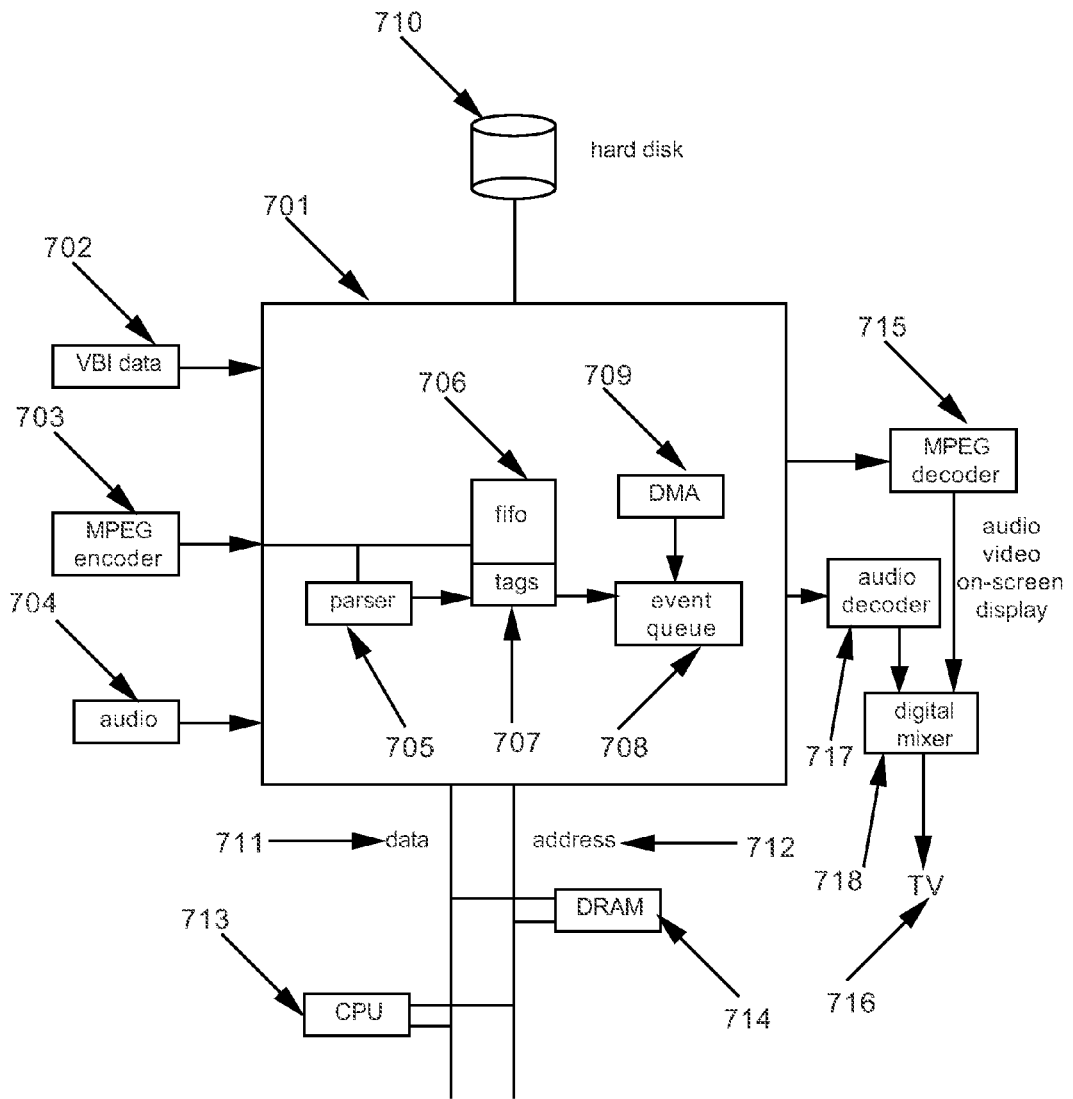

Fig. 7



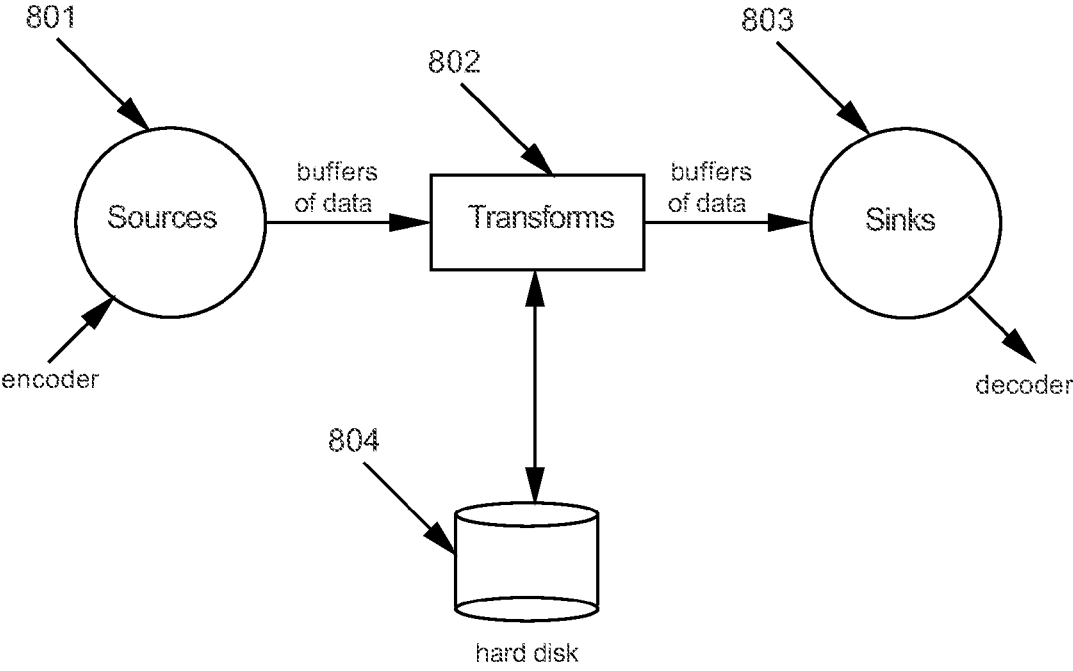

Fig. 8

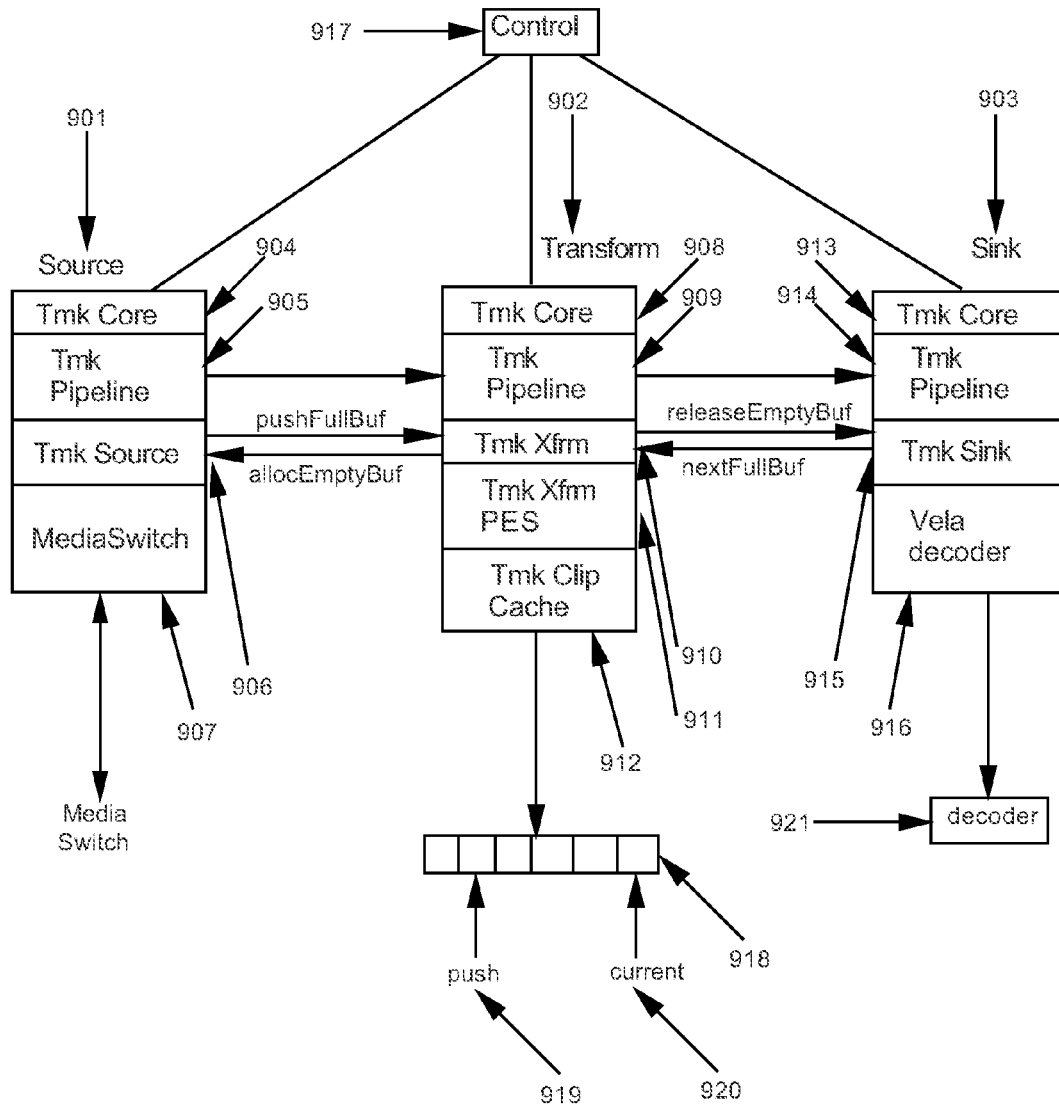

Fig. 9

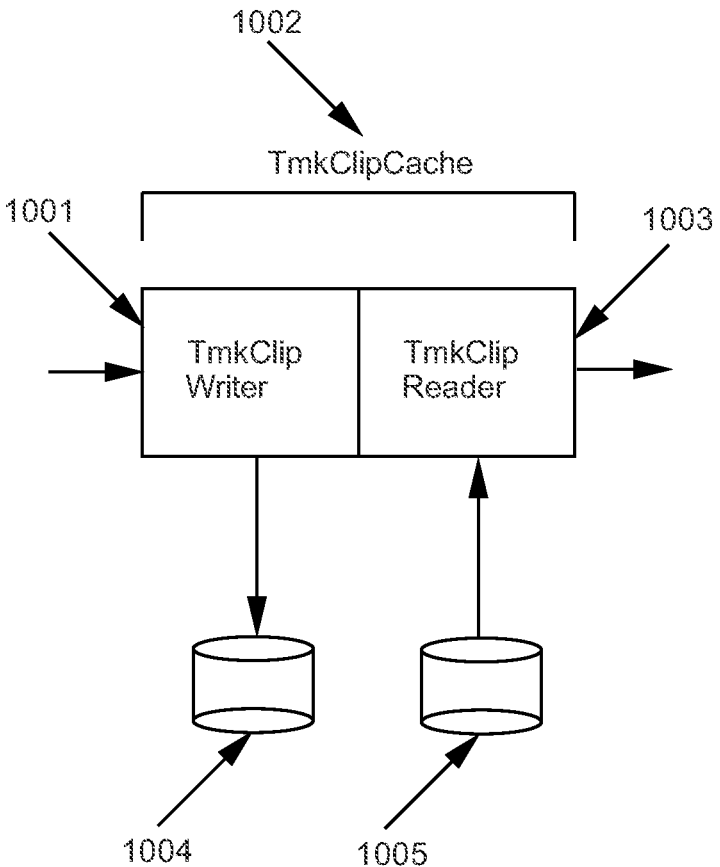

Fig. 10

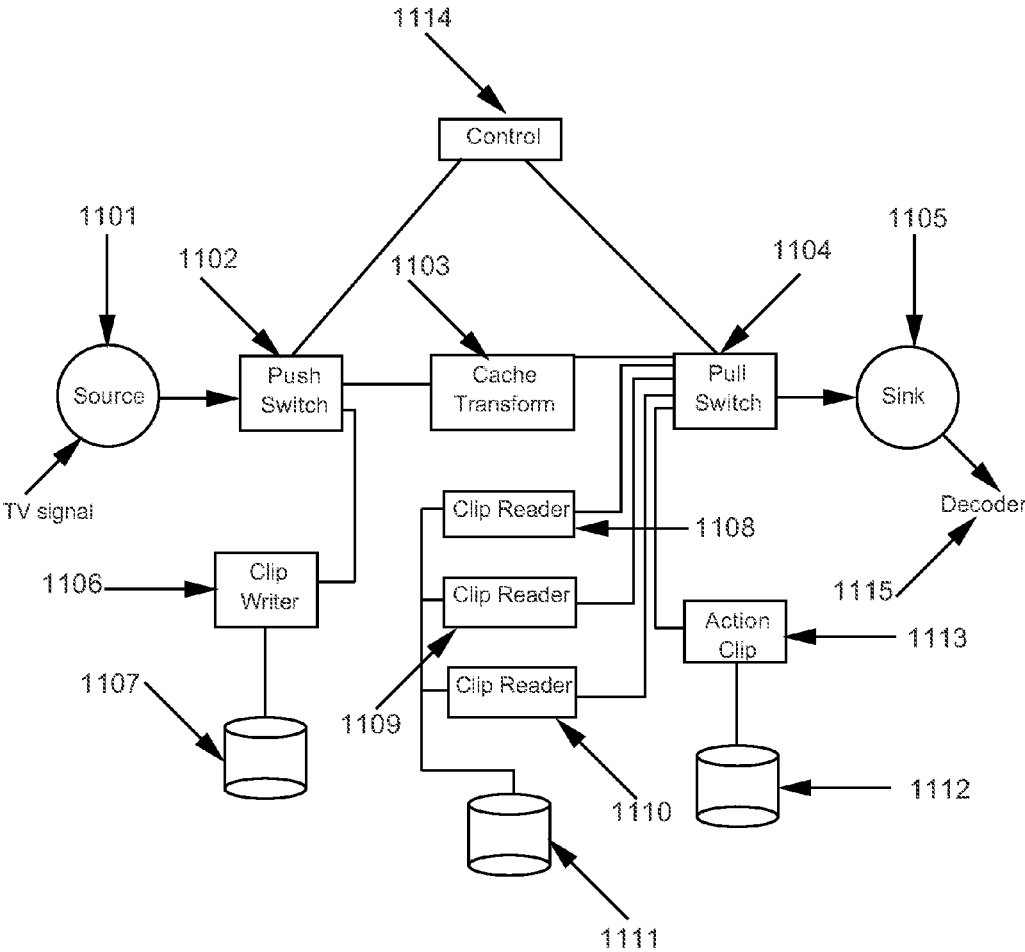

Fig. 11

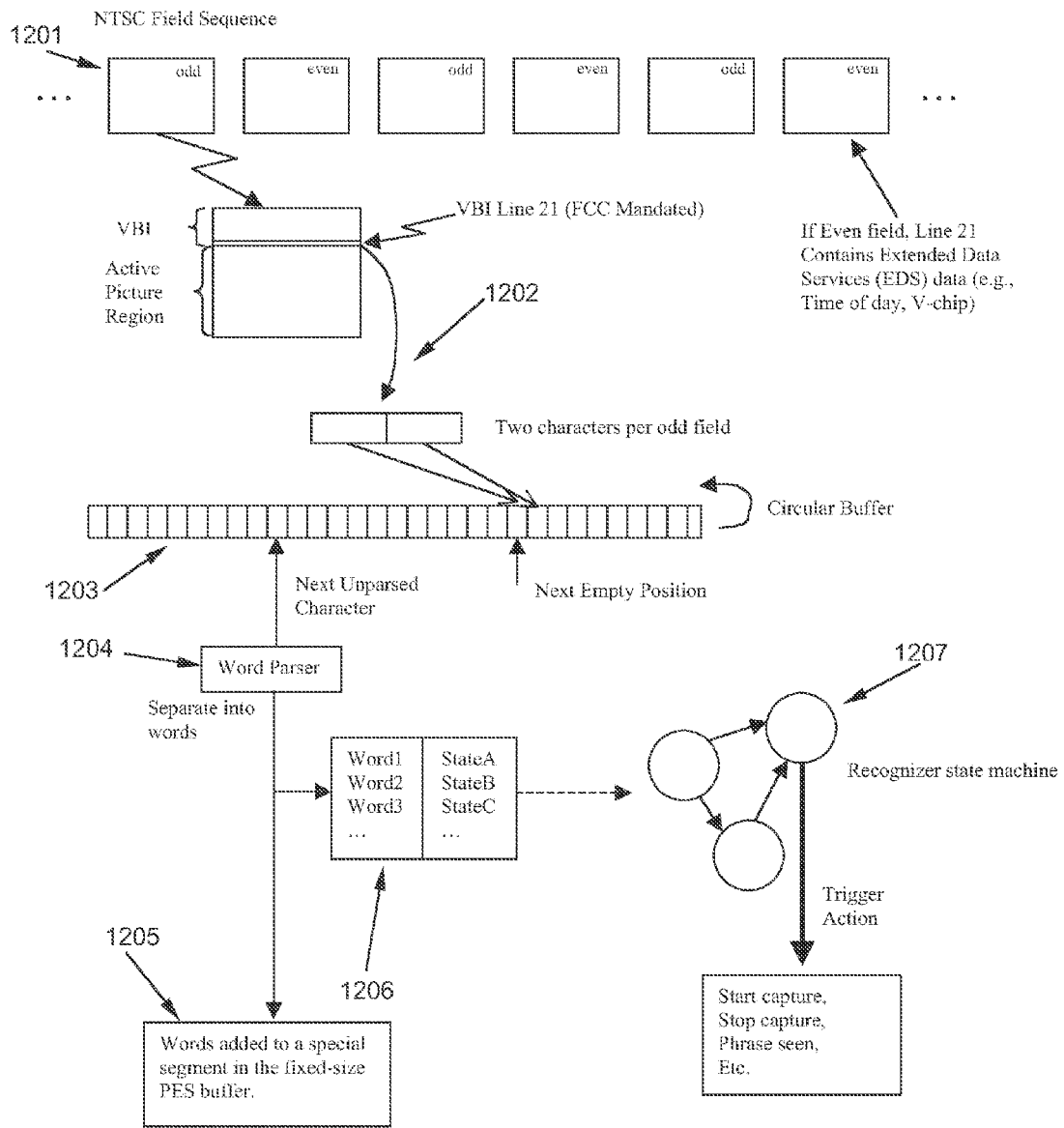

Fig. 12

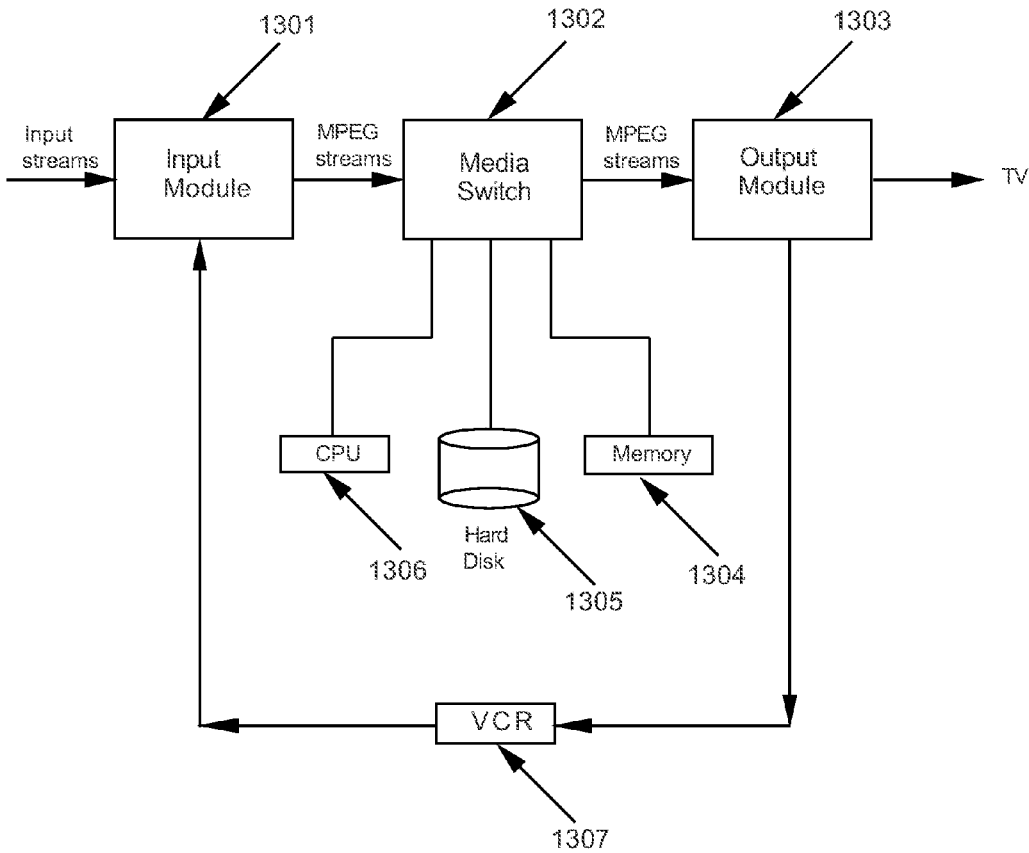

Fig. 13

## MULTIPLE OUTLET DIGITAL VIDEO RECORDING SYSTEM

### CROSS-REFERENCE TO RELATED APPLICATIONS; BENEFIT CLAIM

**[0001]** This application claims benefit as a Continuation of application Ser. No. 14/017,165, filed Sep. 3, 2013, now U.S. Pat. No. 8,948,569, issued Feb. 3, 2015, which claims benefit as a Continuation of application Ser. No. 12/430,781, filed Apr. 24, 2009, now U.S. Pat. No. 8,526,781, Sep. 3, 2013, which claims benefit as a Continuation of application Ser. No. 10/081,776, filed Feb. 20, 2002, now U.S. Pat. No. 7,529,465, issued May 5, 2009, which claims benefit as a Divisional of application Ser. No. 09/827,029, filed Apr. 5, 2001, which claims benefit as a Continuation of application Ser. No. 09/126,071, filed Jul. 30, 1998, now U.S. Pat. No. 6,233,389, issued May 15, 2001, the entire contents of the aforementioned are hereby incorporated by reference as if fully set forth herein under 35 U.S.C. §120. The applicants hereby rescind any disclaimer of claim scope in the parent applications or the prosecution history thereof and advise the USPTO that the claims in this application may be broader than any claim in the parent applications.

**[0002]** The applicants hereby rescind any disclaimer of claim scope in the parent applications or the prosecution history thereof and advise the USPTO that the claims in this application may be broader than any claim in the parent applications.

### BACKGROUND

**[0003]** 1. Technical Field

**[0004]** The invention relates to the time shifting of television broadcast signals. More particularly, the invention relates to the real time capture, storage, and display of television broadcast signals.

**[0005]** 2. Description of the Prior Art

**[0006]** The Video Cassette Recorder (VCR) has changed the lives of television (TV) viewers throughout the world. The VCR has offered viewers the flexibility to time-shift TV programs to match their lifestyles.

**[0007]** The viewer stores TV programs onto magnetic tape using the VCR. The VCR gives the viewer the ability to play, rewind, fast forward and pause the stored program material. These functions enable the viewer to pause the program playback whenever he desires, fast forward through unwanted program material or commercials, and to replay favorite scenes. However, a VCR cannot both capture and play back information at the same time.

**[0008]** One approach to solving this problem is to use several VCRs. For example, if two video tape recorders are available, it might be possible to Ping-Pong between the two. In this case, the first recorder is started at the beginning of the program of interest. If the viewer wishes to rewind the broadcast, the second recorder begins recording, while the first recorder is halted, rewound to the appropriate place, and playback initiated. However, at least a third video tape recorder is required if the viewer wishes to fast forward to some point in time after the initial rewind was requested. In this case, the third recorder starts recording the broadcast stream while the second is halted and rewound to the appropriate position. Continuing this exercise, one can quickly see that the equipment becomes unwieldy, unreliable, expensive, and hard to operate, while never supporting

all desired functions. In addition, tapes are of finite length, and may potentially end at inconvenient times, drastically lowering the value of the solution.

**[0009]** The use of digital computer systems to solve this problem has been suggested. U.S. Pat. No. 5,371,551 issued to Logan et al., on 6 Dec. 1994, teaches a method for concurrent video recording and playback. It presents a microprocessor controlled broadcast and playback device. Said device compresses and stores video data onto a hard disk. However, this approach is difficult to implement because the processor requirements for keeping up with the high video rates makes the device expensive and problematic. The microprocessor must be extremely fast to keep up with the incoming and outgoing video data.

**[0010]** It would be advantageous to provide a multimedia time warping system that gives the user the ability to simultaneously record and play back TV broadcast programs. It would further be advantageous to provide a multimedia time warping system that utilizes an approach that decouples the microprocessor from the high video data rates, thereby reducing the microprocessor and system requirements which are at a premium.

### SUMMARY OF THE INVENTION

**[0011]** An embodiment of the invention provides a multimedia time warping system. The embodiment utilizes an easily manipulated, low cost multimedia storage and display system that allows the user to view a television broadcast program with the option of instantly reviewing previous scenes within the program. In addition, an embodiment allows the user to store selected television broadcast programs while the user is simultaneously watching or reviewing another program.

**[0012]** An embodiment of the invention accepts television (TV) input streams in a multitude of forms, for example, analog forms such as National Television Standards Committee (NTSC) or PAL broadcast, and digital forms such as Digital Satellite System (DSS), Digital Broadcast Services (DBS), or Advanced Television Standards Committee (ATSC). Analog TV streams are converted into a digital formatted stream for internal transfer and manipulation, while pre-formatted MPEG streams are extracted from the digital TV signal and manipulated as digital streams.

**[0013]** The system parses the resulting digital stream and generates identifying information associated with at least one video segment of the digital stream. Events are recorded that indicate the type of segment that has been found, where it is located, and when it occurred. The program logic is notified that an event has occurred and the video segment is extracted from buffers.

**[0014]** A parser and event buffer decouple the CPU from having to parse the digital stream and from the real time nature of the data streams. This decoupling allows for slower CPU and bus speeds which translate to lower system costs.

**[0015]** The video segments are stored on a storage device. When a program is requested for display, its video segments are extracted from the storage device and reassembled into a digital stream. The digital stream is sent to a decoder. The decoder converts the digital stream into display output signals and delivers the display output signals to a display.

**[0016]** User control commands are accepted and sent through the system. These commands affect the flow of the digital stream and allow the user to view stored programs

with at least the following functions: reverse, fast forward, play, pause, index, fast/slow reverse play, and fast/slow play. **[0017]** Other aspects and advantages of the invention will become apparent from the following detailed description in combination with the accompanying drawings, illustrating, by way of example, the principles of the invention.

#### BRIEF DESCRIPTION OF THE DRAWINGS

**[0018]** FIG. 1 is a block schematic diagram of a high level view of an embodiment of the invention according to the invention;

**[0019]** FIG. 2 is a block schematic diagram of an embodiment of the invention using multiple input and output modules according to the invention;

**[0020]** FIG. 3 is a schematic diagram of an Moving Pictures Experts Group (MPEG) data stream and its video and audio components according to the invention;

**[0021]** FIG. 4 is a block schematic diagram of a parser and four direct memory access (DMA) input engines contained in the Media Switch according to the invention;

**[0022]** FIG. 5 is a schematic diagram of the components of a packetized elementary stream (PES) buffer according to the invention;

**[0023]** FIG. 6 is a schematic diagram of the construction of a PES buffer from the parsed components in the Media Switch output circular buffers;

**[0024]** FIG. 7 is a block schematic diagram of the Media Switch and the various components that it communicates with according to the invention;

**[0025]** FIG. 8 is a block schematic diagram of a high level view of the program logic according to the invention;

**[0026]** FIG. 9 is a block schematic diagram of a class hierarchy of the program logic according to the invention;

**[0027]** FIG. 10 is a block schematic diagram of an embodiment of the clip cache component of the invention according to the invention;

**[0028]** FIG. 11 is a block schematic diagram of an embodiment of the invention that emulates a broadcast studio video mixer according to the invention;

**[0029]** FIG. 12 is a block schematic diagram of a closed caption parser according to the invention; and

**[0030]** FIG. 13 is a block schematic diagram of a high level view of a preferred embodiment of the invention utilizing a VCR as an integral component of the invention according to the invention.

#### DETAILED DESCRIPTION OF THE INVENTION

**[0031]** An embodiment of the invention provides a multimedia time warping system. A system according to an embodiment of the invention provides a multimedia storage and display system that allows the user to view a television broadcast program with the option of instantly reviewing previous scenes within the program. The embodiment additionally provides the user with the ability to store selected television broadcast programs while simultaneously watching or reviewing another program and to view stored programs with at least the following functions: reverse, fast forward, play, pause, index, fast/slow reverse play, and fast/slow play.

**[0032]** Referring to FIG. 1, an embodiment of the invention has an Input Section **101**, Media Switch **102**, and an Output Section **103**. The Input Section **101** takes television

(TV) input streams in a multitude of forms, for example, National Television Standards Committee (NTSC) or PAL broadcast, and digital forms such as Digital Satellite System (DSS), Digital Broadcast Services (DBS), or Advanced Television Standards Committee (ATSC). DBS, DSS and ATSC are based on standards called Moving Pictures Experts Group 2 (MPEG2) and MPEG2 Transport. MPEG2 Transport is a standard for formatting the digital data stream from the TV source transmitter so that a TV receiver can disassemble the input stream to find programs in the multiplexed signal. The Input Section **101** produces MPEG streams. An MPEG2 transport multiplex supports multiple programs in the same broadcast channel, with multiple video and audio feeds and private data. The Input Section **101** tunes the channel to a particular program, extracts a specific MPEG program out of it, and feeds it to the rest of the system. Analog TV signals are encoded into a similar MPEG format using separate video and audio encoders, such that the remainder of the system is unaware of how the signal was obtained. Information may be modulated into the Vertical Blanking Interval (VBI) of the analog TV signal in a number of standard ways; for example, the North American Broadcast Teletext Standard (NABTS) may be used to modulate information onto lines **10** through **20** of an NTSC signal, while the FCC mandates the use of line **21** for Closed Caption (CC) and Extended Data Services (EDS). Such signals are decoded by the input section and passed to the other sections as if they were delivered via an MPEG2 private data channel.

**[0033]** The Media Switch **102** mediates between a micro-processor CPU **106**, hard disk or storage device **105**, and memory **104**. Input streams are converted to an MPEG stream and sent to the Media Switch **102**. The Media Switch **102** buffers the MPEG stream into memory. It then performs two operations if the user is watching real time TV: the stream is sent to the Output Section **103** and it is written simultaneously to the hard disk or storage device **105**.

**[0034]** The Output Section **103** takes MPEG streams as input and produces an analog TV signal according to the NTSC, PAL, or other required TV standards. The Output Section **103** contains an MPEG decoder, On-Screen Display (OSD) generator, analog TV encoder and audio logic. The OSD generator allows the program logic to supply images which will be overlaid on top of the resulting analog TV signal. Additionally, the Output Section can modulate information supplied by the program logic onto the VBI of the output signal in a number of standard formats, including NABTS, CC and EDS.

**[0035]** With respect to FIG. 2, the invention easily expands to accommodate multiple Input Sections (tuners) **201**, **202**, **203**, **204**, each can be tuned to different types of input. Multiple Output Modules (decoders) **206**, **207**, **208**, **209** are added as well. Special effects such as picture in a picture can be implemented with multiple decoders. The Media Switch **205** records one program while the user is watching another. This means that a stream can be extracted off the disk while another stream is being stored onto the disk.

**[0036]** Referring to FIG. 3, the incoming MPEG stream **301** has interleaved video **302**, **305**, **306** and audio **303**, **304**, **307** segments. These elements must be separated and recombined to create separate video **308** and audio **309** streams or buffers. This is necessary because separate decoders are used to convert MPEG elements back into audio or video analog



components. Such separate delivery requires that time sequence information be generated so that the decoders may be properly synchronized for accurate playback of the signal.

[0037] The Media Switch enables the program logic to associate proper time sequence information with each segment, possibly embedding it directly into the stream. The time sequence information for each segment is called a time stamp. These time stamps are monotonically increasing and start at zero each time the system boots up. This allows the invention to find any particular spot in any particular video segment. For example, if the system needs to read five seconds into an incoming contiguous video stream that is being cached, the system simply has to start reading forward into the stream and look for the appropriate time stamp.

[0038] A binary search can be performed on a stored file to index into a stream. Each stream is stored as a sequence of fixed-size segments enabling fast binary searches because of the uniform time stamping. If the user wants to start in the middle of the program, the system performs a binary search of the stored segments until it finds the appropriate spot, obtaining the desired results with a minimal amount of information. If the signal were instead stored as an MPEG stream, it would be necessary to linearly parse the stream from the beginning to find the desired location.

[0039] With respect to FIG. 4, the Media Switch contains four input Direct Memory Access (DMA) engines 402, 403, 404, 405 each DMA engine has an associated buffer 410, 411, 412, 413. Conceptually, each DMA engine has a pointer 406, a limit for that pointer 407, a next pointer 408, and a limit for the next pointer 409. Each DMA engine is dedicated to a particular type of information, for example, video 402, audio 403, and parsed events 405. The buffers 410, 411, 412, 413 are circular and collect the specific information. The DMA engine increments the pointer 406 into the associated buffer until it reaches the limit 407 and then loads the next pointer 408 and limit 409. Setting the pointer 406 and next pointer 408 to the same value, along with the corresponding limit value creates a circular buffer. The next pointer 408 can be set to a different address to provide vector DMA.

[0040] The input stream flows through a parser 401. The parser 401 parses the stream looking for MPEG distinguished events indicating the start of video, audio or private data segments. For example, when the parser 401 finds a video event, it directs the stream to the video DMA engine 402. The parser 401 buffers up data and DMAs it into the video buffer 410 through the video DMA engine 402. At the same time, the parser 401 directs an event to the event DMA engine 405 which generates an event into the event buffer 413. When the parser 401 sees an audio event, it redirects the byte stream to the audio DMA engine 403 and generates an event into the event buffer 413. Similarly, when the parser 401 sees a private data event, it directs the byte stream to the private data DMA engine 404 and directs an event to the event buffer 413. The Media Switch notifies the program logic via an interrupt mechanism when events are placed in the event buffer.

[0041] Referring to FIGS. 4 and 5, the event buffer 413 is filled by the parser 401 with events. Each event 501 in the event buffer has an offset 502, event type 503, and time stamp field 504. The parser 401 provides the type and offset of each event as it is placed into the buffer. For example, when an audio event occurs, the event type field is set to an

audio event and the offset indicates the location in the audio buffer 411. The program logic knows where the audio buffer 411 starts and adds the offset to find the event in the stream. The address offset 502 tells the program logic where the next event occurred, but not where it ended. The previous event is cached so the end of the current event can be found as well as the length of the segment.

[0042] With respect to FIGS. 5 and 6, the program logic reads accumulated events in the event buffer 602 when it is interrupted by the Media Switch 601. From these events the program logic generates a sequence of logical segments 603 which correspond to the parsed MPEG segments 615. The program logic converts the offset 502 into the actual address 610 of each segment, and records the event length 609 using the last cached event. If the stream was produced by encoding an analog signal, it will not contain Program Time Stamp (PTS) values, which are used by the decoders to properly present the resulting output. Thus, the program logic uses the generated time stamp 504 to calculate a simulated PTS for each segment and places that into the logical segment timestamp 607. In the case of a digital TV stream, PTS values are already encoded in the stream. The program logic extracts this information and places it in the logical segment timestamp 607.

[0043] The program logic continues collecting logical segments 603 until it reaches the fixed buffer size. When this occurs, the program logic generates a new buffer, called a Packetized Elementary Stream (PES) 605 buffer containing these logical segments 603 in order, plus ancillary control information. Each logical segment points 604 directly to the circular buffer, e.g., the video buffer 613, filled by the Media Switch 601. This new buffer is then passed to other logic components, which may further process the stream in the buffer in some way, such as presenting it for decoding or writing it to the storage media. Thus, the MPEG data is not copied from one location in memory to another by the processor. This results in a more cost effective design since lower memory bandwidth and processor bandwidth is required.

[0044] A unique feature of the MPEG stream transformation into PES buffers is that the data associated with logical segments need not be present in the buffer itself, as presented above. When a PES buffer is written to storage, these logical segments are written to the storage medium in the logical order in which they appear. This has the effect of gathering components of the stream, whether they be in the video, audio or private data circular buffers, into a single linear buffer of stream data on the storage medium. The buffer is read back from the storage medium with a single transfer from the storage media, and the logical segment information is updated to correspond with the actual locations in the buffer 606. Higher level program logic is unaware of this transformation, since it handles only the logical segments, thus stream data is easily managed without requiring that the data ever be copied between locations in DRAM by the CPU.

[0045] A unique aspect of the Media Switch is the ability to handle high data rates effectively and inexpensively. It performs the functions of taking video and audio data in, sending video and audio data out, sending video and audio data to disk, and extracting video and audio data from the disk on a low cost platform. Generally, the Media Switch runs asynchronously and autonomously with the micropro-

cessor CPU, using its DMA capabilities to move large quantities of information with minimal intervention by the CPU.

**[0046]** Referring to FIG. 7, the input side of the Media Switch **701** is connected to an MPEG encoder **703**. There are also circuits specific to MPEG audio **704** and vertical blanking interval (VBI) data **702** feeding into the Media Switch **701**. If a digital TV signal is being processed instead, the MPEG encoder **703** is replaced with an MPEG2 Transport Demultiplexer, and the MPEG audio encoder **704** and VBI decoder **702** are deleted. The demultiplexer multiplexes the extracted audio, video and private data channel streams through the video input Media Switch port.

**[0047]** The parser **705** parses the input data stream from the MPEG encoder **703**, audio encoder **704** and VBI decoder **702**, or from the transport demultiplexer in the case of a digital TV stream. The parser **705** detects the beginning of all of the important events in a video or audio stream, the start of all of the frames, the start of sequence headers—all of the pieces of information that the program logic needs to know about in order to both properly play back and perform special effects on the stream, e.g. fast forward, reverse, play, pause, fast/slow play, indexing, and fast/slow reverse play.

**[0048]** The parser **705** places tags **707** into the FIFO **706** when it identifies video or audio segments, or is given private data. The DMA **709** controls when these tags are taken out. The tags **707** and the DMA addresses of the segments are placed into the event queue **708**. The frame type information, whether it is a start of a video I-frame, video B-frame, video P-frame, video PES, audio PES, a sequence header, an audio frame, or private data packet, is placed into the event queue **708** along with the offset in the related circular buffer where the piece of information was placed. The program logic operating in the CPU **713** examines events in the circular buffer after it is transferred to the DRAM **714**.

**[0049]** The Media Switch **701** has a data bus **711** that connects to the CPU **713** and DRAM **714**. An address bus **712** is also shared between the Media Switch **701**, CPU **713**, and DRAM **714**. A hard disk or storage device **710** is connected to one of the ports of the Media Switch **701**. The Media Switch **701** outputs streams to an MPEG video decoder **715** and a separate audio decoder **717**. The audio decoder **717** signals contain audio cues generated by the system in response to the user's commands on a remote control or other internal events. The decoded audio output from the MPEG decoder is digitally mixed **718** with the separate audio signal. The resulting signals contain video, audio, and on-screen displays and are sent to the TV **716**.

**[0050]** The Media Switch **701** takes in 8-bit data and sends it to the disk, while at the same time extracts another stream of data off of the disk and sends it to the MPEG decoder **715**. All of the DMA engines described above can be working at the same time. The Media Switch **701** can be implemented in hardware using a Field Programmable Gate Array (FPGA), ASIC, or discrete logic.

**[0051]** Rather than having to parse through an immense data stream looking for the start of where each frame would be, the program logic only has to look at the circular event buffer in DRAM **714** and it can tell where the start of each frame is and the frame type. This approach saves a large amount of CPU power, keeping the real time requirements of the CPU **713** small. The CPU **713** does not have to be very fast at any point in time. The Media Switch **701** gives the

CPU **713** as much time as possible to complete tasks. The parsing mechanism **705** and event queue **708** decouple the CPU **713** from parsing the audio, video, and buffers and the real time nature of the streams, which allows for lower costs. It also allows the use of a bus structure in a CPU environment that operates at a much lower clock rate with much cheaper memory than would be required otherwise.

**[0052]** The CPU **713** has the ability to queue up one DMA transfer and can set up the next DMA transfer at its leisure. This gives the CPU **713** large time intervals within which it can service the DMA controller **709**. The CPU **713** may respond to a DMA interrupt within a larger time window because of the large latency allowed. MPEG streams, whether extracted from an MPEG2 Transport or encoded from an analog TV signal, are typically encoded using a technique called Variable Bit Rate encoding (VBR). This technique varies the amount of data required to represent a sequence of images by the amount of movement between those images. This technique can greatly reduce the required bandwidth for a signal, however sequences with rapid movement (such as a basketball game) may be encoded with much greater bandwidth requirements. For example, the Hughes DirecTV satellite system encodes signals with anywhere from 1 to 10 Mb/s of required bandwidth, varying from frame to frame. It would be difficult for any computer system to keep up with such rapidly varying data rates without this structure.

**[0053]** With respect to FIG. 8, the program logic within the CPU has three conceptual components: sources **801**, transforms **802**, and sinks **803**. The sources **801** produce buffers of data. Transforms **802** process buffers of data and sinks **803** consume buffers of data. A transform is responsible for allocating and queuing the buffers of data on which it will operate. Buffers are allocated as if “empty” to sources of data, which give them back “full”. The buffers are then queued and given to sinks as “full”, and the sink will return the buffer “empty”.

**[0054]** A source **801** accepts data from encoders, e.g., a digital satellite receiver. It acquires buffers for this data from the downstream transform, packages the data into a buffer, then pushes the buffer down the pipeline as described above. The source object **801** does not know anything about the rest of the system. The sink **803** consumes buffers, taking a buffer from the upstream transform, sending the data to the decoder, and then releasing the buffer for reuse.

**[0055]** There are two types of transforms **802** used: spatial and temporal. Spatial transforms are transforms that perform, for example, an image convolution or compression/decompression on the buffered data that is passing through. Temporal transforms are used when there is no time relation that is expressible between buffers going in and buffers coming out of a system. Such a transform writes the buffer to a file **804** on the storage medium. The buffer is pulled out at a later time, sent down the pipeline, and properly sequenced within the stream.

**[0056]** Referring to FIG. 9, a C++ class hierarchy derivation of the program logic is shown. The TiVo Media Kernel (Tmk) **904**, **908**, **913** mediates with the operating system kernel. The kernel provides operations such as: memory allocation, synchronization, and threading. The TmkCore **904**, **908**, **913** structures memory taken from the media kernel as an object. It provides operators, new and delete, for constructing and deconstructing the object. Each object

(source **901**, transform **902**, and sink **903**) is multi-threaded by definition and can run in parallel.

**[0057]** The TmkPipeline class **905**, **909**, **914** is responsible for flow control through the system. The pipelines point to the next pipeline in the flow from source **901** to sink **903**. To pause the pipeline, for example, an event called “pause” is sent to the first object in the pipeline. The event is relayed on to the next object and so on down the pipeline. This all happens asynchronously to the data going through the pipeline. Thus, similar to applications such as telephony, control of the flow of MPEG streams is asynchronous and separate from the streams themselves. This allows for a simple logic design that is at the same time powerful enough to support the features described previously, including pause, rewind, fast forward and others. In addition, this structure allows fast and efficient switching between stream sources, since buffered data can be simply discarded and decoders reset using a single event, after which data from the new stream will pass down the pipeline. Such a capability is needed, for example, when switching the channel being captured by the input section, or when switching between a live signal from the input section and a stored stream.

**[0058]** The source object **901** is a TmkSource **906** and the transform object **902** is a TmkXfrm **910**. These are intermediate classes that define standard behaviors for the classes in the pipeline. Conceptually, they handshake buffers down the pipeline. The source object **901** takes data out of a physical data source, such as the Media Switch, and places it into a PES buffer. To obtain the buffer, the source object **901** asks the down stream object in his pipeline for a buffer (allocEmptyBuf). The source object **901** is blocked until there is sufficient memory. This means that the pipeline is self-regulating; it has automatic flow control. When the source object **901** has filled up the buffer, it hands it back to the transform **902** through the pushFullBuf function.

**[0059]** The sink **903** is flow controlled as well. It calls nextFullBuf which tells the transform **902** that it is ready for the next filled buffer. This operation can block the sink **903** until a buffer is ready. When the sink **903** is finished with a buffer (i.e., it has consumed the data in the buffer) it calls releaseEmptyBuf. ReleaseEmptyBuf gives the buffer back to the transform **902**. The transform **902** can then hand that buffer, for example, back to the source object **901** to fill up again. In addition to the automatic flow-control benefit of this method, it also provides for limiting the amount of memory dedicated to buffers by allowing enforcement of a fixed allocation of buffers by a transform. This is an important feature in achieving a cost-effective limited DRAM environment.

**[0060]** The MediaSwitch class **909** calls the allocEmptyBuf method of the TmkClipCache **912** object and receives a PES buffer from it. It then goes out to the circular buffers in the Media Switch hardware and generates PES buffers. The MediaSwitch class **909** fills the buffer up and pushes it back to the TmkClipCache **912** object.

**[0061]** The TmkClipCache **912** maintains a cache file **918** on a storage medium. It also maintains two pointers into this cache: a push pointer **919** that shows where the next buffer coming from the source **901** is inserted; and a current pointer **920** which points to the current buffer used.

**[0062]** The buffer that is pointed to by the current pointer is handed to the Vela decoder class **916**. The Vela decoder class **916** talks to the decoder **921** in the hardware. The decoder **921** produces a decoded TV signal that is subse-

quently encoded into an analog TV signal in NTSC, PAL or other analog format. When the Vela decoder class **916** is finished with the buffer it calls releaseEmptyBuf.

**[0063]** The structure of the classes makes the system easy to test and debug. Each level can be tested separately to make sure it performs in the appropriate manner, and the classes may be gradually aggregated to achieve the desired functionality while retaining the ability to effectively test each object.

**[0064]** The control object **917** accepts commands from the user and sends events into the pipeline to control what the pipeline is doing. For example, if the user has a remote control and is watching TV, the user presses pause and the control object **917** sends an event to the sink **903**, that tells it pause. The sink **903** stops asking for new buffers. The current pointer **920** stays where it is at. The sink **903** starts taking buffers out again when it receives another event that tells it to play. The system is in perfect synchronization; it starts from the frame that it stopped at.

**[0065]** The remote control may also have a fast forward key. When the fast forward key is pressed, the control object **917** sends an event to the transform **902** that tells it to move forward two seconds. The transform **902** finds that the two second time span requires it to move forward three buffers. It then issues a reset event to the downstream pipeline, so that any queued data or state that may be present in the hardware decoders is flushed. This is a critical step, since the structure of MPEG streams requires maintenance of state across multiple frames of data, and that state will be rendered invalid by repositioning the pointer. It then moves the current pointer **920** forward three buffers. The next time the sink **903** calls nextFullBuf it gets the new current buffer. The same method works for fast reverse in that the transform **902** moves the current pointer **920** backwards.

**[0066]** A system clock reference resides in the decoder. The system clock reference is sped up for fast play or slowed down for slow play. The sink simply asks for full buffers faster or slower, depending on the clock speed.

**[0067]** With respect to FIG. 10, two other objects derived from the TmkXfrm class are placed in the pipeline for disk access. One is called TmkClipReader **1003** and the other is called TmkClipWriter **1001**. Buffers come into the TmkClipWriter **1001** and are pushed to a file on a storage medium **1004**. TmkClipReader **1003** asks for buffers which are taken off of a file on a storage medium **1005**. A TmkClipReader **1003** provides only the allocEmptyBuf and pushFullBuf methods, while a TmkClipWriter **1001** provides only the nextFullBuf and releaseEmptyBuf methods. A TmkClipReader **1003** therefore performs the same function as the input, or “push” side of a TmkClipCache **1002**, while a TmkClipWriter **1001** therefore performs the same function as the output, or “pull” side of a TmkClipCache **1002**.

**[0068]** Referring to FIG. 11, an embodiment that accomplishes multiple functions is shown. A source **1101** has a TV signal input. The source sends data to a PushSwitch **1102** which is a transform derived from TmkXfrm. The PushSwitch **1102** has multiple outputs that can be switched by the control object **1114**. This means that one part of the pipeline can be stopped and another can be started at the user’s whim. The user can switch to different storage devices. The PushSwitch **1102** could output to a TmkClipWriter **1106**, which goes onto a storage device **1107** or write to the cache transform **1103**.

**[0069]** An important feature of this apparatus is the ease with which it can selectively capture portions of an incoming signal under the control of program logic. Based on information such as the current time, or perhaps a specific time span, or perhaps via a remote control button press by the viewer, a TmkClipWriter **1106** may be switched on to record a portion of the signal, and switched off at some later time. This switching is typically caused by sending a “switch” event to the PushSwitch **1102** object.

**[0070]** An additional method for triggering selective capture is through information modulated into the VBI or placed into an MPEG private data channel. Data decoded from the VBI or private data channel is passed to the program logic. The program logic examines this data to determine if the data indicates that capture of the TV signal into which it was modulated should begin. Similarly, this information may also indicate when recording should end, or another data item may be modulated into the signal indicating when the capture should end. The starting and ending indicators may be explicitly modulated into the signal or other information that is placed into the signal in a standard fashion may be used to encode this information.

**[0071]** With respect to FIG. **12**, an example is shown which demonstrates how the program logic scans the words contained within the closed caption (CC) fields to determine starting and ending times, using particular words or phrases to trigger the capture. A stream of NTSC or PAL fields **1201** is presented. CC bytes are extracted from each odd field **1202**, and entered in a circular buffer **1203** for processing by the Word Parser **1204**. The Word Parser **1204** collects characters until it encounters a word boundary, usually a space, period or other delineating character. Recall from above, that the MPEG audio and video segments are collected into a series of fixed-size PES buffers. A special segment is added to each PES buffer to hold the words extracted from the CC field **1205**. Thus, the CC information is preserved in time synchronization with the audio and video, and can be correctly presented to the viewer when the stream is displayed. This also allows the stored stream to be processed for CC information at the leisure of the program logic, which spreads out load, reducing cost and improving efficiency. In such a case, the words stored in the special segment are simply passed to the state table logic **1206**.

**[0072]** During stream capture, each word is looked up in a table **1206** which indicates the action to take on recognizing that word. This action may simply change the state of the recognizer state machine **1207**, or may cause the state machine **1207** to issue an action request, such as “start capture”, “stop capture”, “phrase seen”, or other similar requests. Indeed, a recognized word or phrase may cause the pipeline to be switched; for example, to overlay a different audio track if undesirable language is used in the program.

**[0073]** Note that the parsing state table **1206** and recognizer state machine **1207** may be modified or changed at any time. For example, a different table and state machine may be provided for each input channel. Alternatively, these elements may be switched depending on the time of day, or because of other events.

**[0074]** Referring to FIG. **11**, a PullSwitch is added **1104** which outputs to the sink **1105**. The sink **1105** calls nextFullBuf and releaseEmptyBuf to get or return buffers from the PullSwitch **1104**. The PullSwitch **1104** can have any number of inputs. One input could be an ActionClip **1113**. The remote control can switch between input sources. The

control object **1114** sends an event to the PullSwitch **1104**, telling it to switch. It will switch from the current input source to whatever input source the control object selects.

**[0075]** An ActionClip class provides for sequencing a number of different stored signals in a predictable and controllable manner, possibly with the added control of viewer selection via a remote control. Thus, it appears as a derivative of a TmkXfrm object that accepts a “switch” event for switching to the next stored signal.

**[0076]** This allows the program logic or user to create custom sequences of video output. Any number of video segments can be lined up and combined as if the program logic or user were using a broadcast studio video mixer. TmkClipReaders **1108**, **1109**, **1110** are allocated and each is hooked into the PullSwitch **1104**. The PullSwitch **1104** switches between the TmkClipReaders **1108**, **1109**, **1110** to combine video and audio clips. Flow control is automatic because of the way the pipeline is constructed. The Push and Pull Switches are the same as video switches in a broadcast studio.

**[0077]** The derived class and resulting objects described here may be combined in an arbitrary way to create a number of different useful configurations for storing, retrieving, switching and viewing of TV streams. For example, if multiple input and output sections are available, one input is viewed while another is stored, and a picture-in-picture window generated by the second output is used to preview previously stored streams. Such configurations represent a unique and novel application of software transformations to achieve the functionality expected of expensive, sophisticated hardware solutions within a single cost-effective device.

**[0078]** With respect to FIG. **13**, a high-level system view is shown which implements a VCR backup. The Output Module **1303** sends TV signals to the VCR **1307**. This allows the user to record TV programs directly on to video tape. The invention allows the user to queue up programs from disk to be recorded on to video tape and to schedule the time that the programs are sent to the VCR **1307**. Title pages (EPG data) can be sent to the VCR **1307** before a program is sent. Longer programs can be scaled to fit onto smaller video tapes by speeding up the play speed or dropping frames.

**[0079]** The VCR **1307** output can also be routed back into the Input Module **1301**. In this configuration the VCR acts as a backup system for the Media Switch **1302**. Any overflow storage or lower priority programming is sent to the VCR **1307** for later retrieval.

**[0080]** The Input Module **1301** can decode and pass to the remainder of the system information encoded on the Vertical Blanking Interval (VBI). The Output Module **1303** can encode into the output VBI data provided by the remainder of the system. The program logic may arrange to encode identifying information of various kinds into the output signal, which will be recorded onto tape using the VCR **1307**. Playing this tape back into the input allows the program logic to read back this identifying information, such that the TV signal recorded on the tape is properly handled. For example, a particular program may be recorded to tape along with information about when it was recorded, the source network, etc. When this program is played back into the Input Module, this information can be used to control storage of the signal, presentation to the viewer, etc.

**[0081]** One skilled in the art will readily appreciate that such a mechanism may be used to introduce various data items to the program logic which are not properly conceived of as television signals. For instance, software updates or other data may be passed to the system. The program logic receiving this data from the television stream may impose controls on how the data is handled, such as requiring certain authentication sequences and/or decrypting the embedded information according to some previously acquired key. Such a method works for normal broadcast signals as well, leading to an efficient means of providing non-TV control information and data to the program logic.

**[0082]** Additionally, one skilled in the art will readily appreciate that although a VCR is specifically mentioned above any multimedia recording device (e.g., a Digital Video Disk-Random Access Memory (DVD-RAM) recorder) is easily substituted in its place.

**[0083]** Although the invention is described herein with reference to the preferred embodiment, one skilled in the art will readily appreciate that other applications may be substituted for those set forth herein without departing from the spirit and scope of the present invention. For example, the invention can be used in the detection of gambling casino crime. The input section of the invention is connected to the casino's video surveillance system. Recorded video is cached and simultaneously output to external VCRs. The user can switch to any video feed and examine (i.e., rewind, play, slow play, fast forward, etc.) a specific segment of the recorded video while the external VCRs are being loaded with the real-time input video. Accordingly, the invention should only be limited by the Claims included below.

1. A method for a digital video recorder, comprising:

receiving a first multimedia program from a first input tuner and a second multimedia program from a second input tuner;

as the first multimedia program and second multimedia program are being received, storing the first multimedia program and the second multimedia program in digital form on at least one storage device;

simultaneously retrieving for play back a video segment from the first multimedia program whose storage is in progress and the second multimedia program whose storage is in progress using video segment identifying information generated by the digital video recorder for at least one video segment in the first multimedia program whose storage is in progress and video segment identifying information generated by the digital video recorder for at least one video segment in the second multimedia program whose storage is in progress to cause delivery of selected video segments to an output subsystem, the digital video recorder automatically generating video segment identifying information for specific video segments in multimedia programs; and

wherein the simultaneously retrieving for play back step allows playback rate and direction of each multimedia program to be controlled individually and simultaneously to perform at least one of: fast forward, rewind, pause, or play functions.

2. The method of claim 1, wherein the output subsystem converts video segments for the first multimedia program whose storage is in progress and the second multimedia program whose storage is in progress into display output signals.

3. The method of claim 2, further comprising:

inserting on-screen displays into a display output signal.

4. The method of claim 1, wherein playback rate and direction of a multimedia program commands are received from a remote control.

5. The method of claim 1, wherein the retrieving for play back step sends a multimedia program to a multimedia device.

6. The method of claim 1, further comprising:

creating custom sequences of video and/or audio output; and

wherein the creating step allows any number of video and/or audio segments of multimedia programs to be lined up and combined and stored on the at least one storage device.

7. The method of claim 1, further comprising the step of: receiving digital multimedia program signals using a plurality of input tuners; and

wherein each of the input tuners among the plurality of input tuners individually receives a specific multimedia program.

8. The method of claim 7, further comprising the step of: synchronizing video and audio components of a multimedia program for proper playback.

9. The method of claim 1, wherein an input tuner receives at least one of: software updates or data.

10. The method of claim 1, wherein the simultaneously retrieving for play back step plays back the first multimedia program whose storage is in progress and the second multimedia program whose storage is in progress in a picture in a picture format to a display device.

11. The method of claim 1, wherein an input tuner receives a specific multimedia program in response to a command received from a remote control.

12. A non-transitory computer-readable medium storing one or more sequences of instructions for a digital video recorder, which instructions, when executed by one or more processors, cause the one or more processors to perform:

receiving a first multimedia program from a first input tuner and a second multimedia program from a second input tuner;

as the first multimedia program and second multimedia program are being received, storing the first multimedia program and the second multimedia program in digital form on at least one storage device;

simultaneously retrieving for play back a video segment from the first multimedia program whose storage is in progress and the second multimedia program whose storage is in progress using video segment identifying information generated by the digital video recorder for at least one video segment in the first multimedia program whose storage is in progress and video segment identifying information generated by the digital video recorder for at least one video segment in the second multimedia program whose storage is in progress to cause delivery of selected video segments to an output subsystem, the digital video recorder automatically generating video segment identifying information for specific video segments in multimedia programs; and

wherein the simultaneously retrieving for play back step allows playback rate and direction of each multimedia

- program to be controlled individually and simultaneously to perform at least one of: fast forward, rewind, pause, or play functions.
13. The non-transitory computer-readable medium of claim 12, wherein the output subsystem converts video segments for the first multimedia program whose storage is in progress and the second multimedia program whose storage is in progress into display output signals.
14. The non-transitory computer-readable medium of claim 13, further comprising:  
inserting on-screen displays into a display output signal.
15. The non-transitory computer-readable medium of claim 12, wherein playback rate and direction of a multimedia program commands are received from a remote control.
16. The non-transitory computer-readable medium of claim 12, wherein the retrieving for play back step sends a multimedia program to a multimedia device.
17. The non-transitory computer-readable medium of claim 12, further comprising:  
creating custom sequences of video and/or audio output;  
and  
wherein the creating step allows any number of video and/or audio segments of multimedia programs to be lined up and combined and stored on the at least one storage device.
18. The non-transitory computer-readable medium of claim 12, further comprising:  
receiving digital multimedia program signals using a plurality of input tuners; and  
wherein each of the input tuners among the plurality of input tuners individually receives a specific multimedia program.
19. The non-transitory computer-readable medium of claim 18, further comprising:  
synchronizing video and audio components of a multimedia program for proper playback.
20. The non-transitory computer-readable medium of claim 12, wherein at least one input tuner receives at least one of: software updates or data.
21. The non-transitory computer-readable medium of claim 12, wherein the simultaneously retrieving for play back step plays back the first multimedia program whose storage is in progress and the second multimedia program whose storage is in progress in a picture in a picture format to a display device.
22. The non-transitory computer-readable medium of claim 12, wherein an input tuner receives a specific multimedia program in response to a command received from a remote control.
23. A digital video recorder, comprising:  
a first input tuner;  
a second input tuner;  
wherein a first multimedia program is received from the first input tuner and a second multimedia program is received from the second input tuner;  
storing logic, implemented at least partially in hardware, that, as the first multimedia program and second multimedia program are being received, stores the first multimedia program and the second multimedia program in digital form on at least one storage device;  
content retrieval logic, implemented at least partially in hardware, that simultaneously retrieves for play back a

- video segment from the first multimedia program whose storage is in progress and the second multimedia program whose storage is in progress using video segment identifying information generated by the digital video recorder for at least one video segment in the first multimedia program whose storage is in progress and video segment identifying information generated by the digital video recorder for at least one video segment in the second multimedia program whose storage is in progress to cause delivery of selected video segments to an output subsystem, the digital video recorder automatically generates video segment identifying information for specific video segments in multimedia programs; and  
wherein the content retrieval logic allows playback rate and direction of each multimedia program to be controlled individually and simultaneously to perform at least one of: fast forward, rewind, pause, or play functions.
24. The apparatus of claim 23, wherein the output subsystem converts video segments for the first multimedia program whose storage is in progress and the second multimedia program whose storage is in progress into display output signals.
25. The apparatus of claim 24, further comprising:  
logic, implemented at least partially in hardware, that inserting on-screen displays into a display output signal.
26. The apparatus of claim 23, wherein playback rate and direction of a multimedia program commands are received from a remote control.
27. The apparatus of claim 23, wherein the content retrieval logic sends a multimedia program to a multimedia device.
28. The apparatus of claim 23, further comprising:  
sequence creation logic, implemented at least partially in hardware, that creates custom sequences of video and/or audio output; and  
wherein the sequence creation logic allows any number of video and/or audio segments of multimedia programs to be lined up and combined and stored on the at least one storage device.
29. The apparatus of claim 23, further comprising:  
a plurality of input tuners that receive digital multimedia program signals; and  
wherein each of the input tuners among the plurality of input tuners individually receives a specific multimedia program.
30. The apparatus of claim 29, further comprising:  
logic, implemented at least partially in hardware, that synchronizes video and audio components of a multimedia program for proper playback.
31. The apparatus of claim 23, wherein an input tuner receives at least one of: software updates or data.
32. The apparatus of claim 23, wherein the content retrieval logic plays back the first multimedia program whose storage is in progress and the second multimedia program whose storage is in progress in a picture in a picture format to a display device.
33. The apparatus of claim 23, wherein an input tuner receives a specific multimedia program in response to a command received from a remote control.