

(12) PATENT
(19) AUSTRALIAN PATENT OFFICE

(11) Application No. AU 199923201 B2
(10) Patent No. 748616

(54) Title
Medication delivery apparatus

(51)⁶ International Patent Classification(s)
A61M 005/148

(21) Application No: 199923201

(22) Application Date: 1999 .01 .14

(87) WIPO No: W099/36112

(30) Priority Data

(31) Number	(32) Date	(33) Country
09/008111	1998 .01 .16	US

(43) Publication Date : 1999 .08 .02

(43) Publication Journal Date : 1999 .10 .07

(44) Accepted Journal Date : 2002 .06 .06

(71) Applicant(s)
Tandem Medical

(72) Inventor(s)
Marc S. Lieberman; Marc C. Doyle; Bobby E. Rogers

(74) Agent/Attorney
SPRUSON and FERGUSON,GPO Box 3898,SYDNEY NSW 2001

(56) Related Art
US 4741736
US 4507114
US 5176634

CORRECTED
VERSION*



PCT WORLD INTELLECTUAL PROPERTY ORGANIZATION.
pages 1/18-18/18, drawings, replaced by new pages 1/17-17/17; due to
INTERNATIONAL PATENT COOPERATION TREATY (PCT)
late transmittal by the receiving Office

(51) International Patent Classification 6 : A61M 5/148	A1	(11) International Publication Number: WO 99/36112 (43) International Publication Date: 22 July 1999 (22.07.99)
(21) International Application Number: PCT/US99/00808 (22) International Filing Date: 14 January 1999 (14.01.99) (30) Priority Data: 09/008,111 16 January 1998 (16.01.98) US (71) Applicant: TANDEM MEDICAL [US/US]; Suite 220, 16880 West Bernardo Drive, San Diego, CA 92127 (US). (72) Inventors: LIEBERMAN, Marc, S.; 15794 Riparian Road, Poway, CA 92064 (US). DOYLE, Marc, C.; Apartment 206, 505 West Broadway, San Diego, CA 92101 (US). ROGERS, Bobby, E.; 3525 Del Mar Heights Road, Del Mar, CA 92130 (US). (74) Agent: REITER, Stephen, E.; Gray Cary Ware & Freidenrich LLP, Suite 1600, 4365 Executive Drive, San Diego, CA 92121 (US).	(81) Designated States: AL, AM, AT, AU, AZ, BA, BB, BG, BR, BY, CA, CH, CN, CU, CZ, DE, DK, EE, ES, FI, GB, GD, GE, GH, GM, HR, HU, ID, IL, IN, IS, JP, KE, KG, KP, KR, KZ, LC, LK, LR, LS, LT, LU, LV, MD, MG, MK, MN, MW, MX, NO, NZ, PL, PT, RO, RU, SD, SE, SG, SI, SK, SL, TJ, TM, TR, TT, UA, UG, UZ, VN, YU, ZW, ARIPO patent (GH, GM, KE, LS, MW, SD, SZ, UG, ZW), Eurasian patent (AM, AZ, BY, KG, KZ, MD, RU, TJ, TM), European patent (AT, BE, CH, CY, DE, DK, ES, FI, FR, GB, GR, IE, IT, LU, MC, NL, PT, SE), OAPI patent (BF, BJ, CF, CG, CI, CM, GA, GN, GW, ML, MR, NE, SN, TD, TG). Published <i>With international search report. Before the expiration of the time limit for amending the claims and to be republished in the event of the receipt of amendments.</i>	

(54) Title: MEDICATION DELIVERY APPARATUS

(57) Abstract

It is a primary object of the present invention to provide an automated system based on an integral fluid bag for administering a variety of intravenous drug regimens and reducing the vagaries of existing manual systems. The fluid has multiple chambers configured to implement a prescribed intravenous medical therapy. Each chamber's geometry (size, shape), sequence and position, alone and in combination with the other chambers, matches the prescribed intravenous therapy or drug regimen. The bag's configuration assures that the intravenous therapy is administered in accordance with the prescribed drug regimen, thus automating the previous manual method. A choice of fluid bag configurations may be stocked so that a prescription for well known and widely accepted drug regimens may be filled by merely selecting a bag with the appropriate chamber configuration and filling it with the prescribed medications.

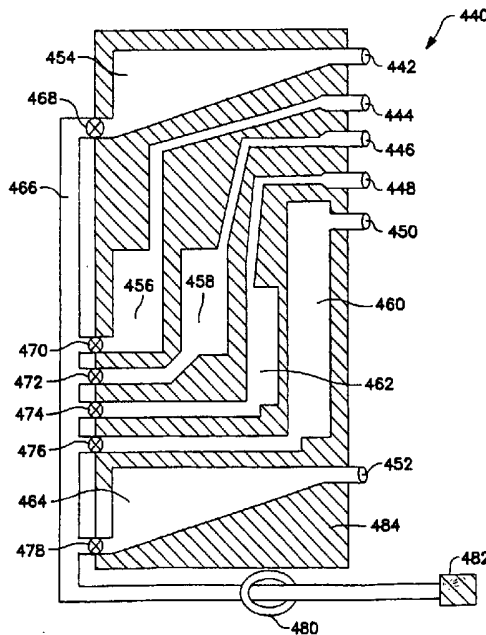

*(Referred to in PCT Gazette No. 41/1999, Section II)

MEDICATION DELIVERY APPARATUSFIELD OF THE INVENTION

The invention relates generally to apparatus and methods for the intravenous infusion of medication and, 5 more particularly, to the automatic administration of intermittent medications in accordance with a predetermined medical therapy. A multichamber fluid bag is manufactured with a particular chamber size and geometry for implementing a prescribed infusion therapy. Because the 10 infusion therapy is implemented by the bag's chamber configuration, the administration of a complex medical infusion therapy is simplified.

BACKGROUND OF THE INVENTION

15 It is now common for intravenous medications such as antibiotics, antivirals, antiemetics, chemotherapy and biotechnology drugs to be administered intermittently with a frequency as often as multiple times per day. Depending on the frequency of administration, the patient is either 20 repeatedly connected to and disconnected from an intravenous (I.V.) line or is continuously connected to an I.V. line between administrations. In either case, the intermittent medications are generally administered by trained personnel using predefined procedures that often 25 include a series of manual steps and a large number of disposable supplies. Each manual step in these procedures

increases the risks associated with multiple manipulations and entry of I.V. sites.

The predefined procedures attempt to ensure the proper administration and the proper dosing of medication, 5 while preventing incompatibilities between different drugs and preventing I.V. lines from clotting off between doses. Unfortunately, because of the manual steps included in these procedures, they have not been entirely successful in guaranteeing that medications are administered in the 10 correct sequence, at the correct infusion rates, and in the correct volumes. Further, if the appropriate procedural steps are not performed within the required time frames, clots may form in the I.V. lines. Also, the manual steps included in these administration procedures are the 15 principle source of infection and other complications that may arise during intermittent infusion therapy. Such problems and complications result in a longer hospital stay for the affected patient. Recent trends which have the patient trained to administer their own medications at home 20 only exacerbate the problems and risks associated with intermittent infusion therapy. Further, elaborate or complicated infusion procedures are more likely to give rise to patient non-compliance by an untrained and less sophisticated home infusion patient.

25 One prevalent example of home health care therapy is the delivery of antibiotics and other medications utilizing the SASH protocol. SASH is an acronym that

stands for Saline-Antibiotic-Saline-Heparin. The patient is trained to follow the SASH protocol by first attaching a saline filled syringe to the catheter to flush and clear the line. The patient then attaches a second syringe
5 filled with the desired medicine or the patient attaches an IV set connected to a minibag, or other container, to the catheter and the medicine is delivered to the patient. A third syringe filled with saline is then attached to the catheter and the saline is injected to clear the line of
10 all medication. Finally, a last syringe is attached to the catheter line and a heparinized solution is injected into the line to keep the line open and maintain the patency of the line for the next time a medication needs to be delivered.

15 The SASH system is currently delivered to the patient in two ways. In the first way the patient is given syringes, needles and vials of saline, medication, and heparin and the patient is instructed how to use the tools. In the second way, pre-filled syringes are supplied to the
20 patient and instruction is provided.

The normal SASH procedure is to clear the line with a small injection of saline, administer the desired medication, clear the line again with another small
injection of saline and then to inject heparin in the line
25 to maintain patency of the IV site. The final injection of heparin into the IV site prevents coagulation in the line until the next administration of medication. Each of the

fluids in the sequence is injected with a separate syringe with the only possible exception being the medication which may be delivered through an IV set.

Some medications require a relatively long period of time to inject because they will cause vein irritation or other complications if they are injected too quickly. To avoid this, the medication is diluted into a volume of solution, typically normal saline or DSW, up to 250cc's. The infusion time can take in excess of 60 minutes.

10 The above procedures involve the use of multiple syringes and needles, vials of saline and heparin and an IV drip set for medications that must be administered over a relatively long period of time. In this instance, the patient is connected to an IV drip after the initial line
15 clearing injection of saline. When the IV drip is finished, the line is again cleared with saline from a syringe and the heparin is injected to maintain the patency of the line. The patient, nurse or pharmacist must fill the syringes from the vials for each of the injections and
20 the needles used in the procedure must then be disposed of in a safe manner.

In addition to the sequential delivery of medications described above as the SASH process, patients frequently receive multiple medications. In some
25 situations, these medications cannot be premixed until just prior to delivery to the patient.

Therefore it would be of great advantage to have a delivery system for multiple medications that does not involve the use of multiple syringes and needles. It would also be an advantage to have a medication delivery system that could be pre-filled with the correct volume of medication or multiple separate medications and which could be administered by the patient automatically in the correct sequence and/or concurrently over the desired time period. A desirable medication delivery system would be extremely simple to use, low in cost and could then be discarded without the usual concerns over the disposal of medical waste.

Accordingly, there exists a need for simplifying the administration of intermittent medical infusion therapy.

It is the object of the present invention to substantially overcome or at least ameliorate one or more of the prior art disadvantages or to achieve at least one of the above desires.

Summary of the Invention

The present invention provides a fluid delivery apparatus for the automated sequential or concurrent infusion of a plurality of pharmacological agents, said apparatus comprising a plurality of chambers each configured with a respective geometry, wherein each chamber configuration controls the volume of each pharmacological agent administered, the rate at which each pharmacological agent is administered, and the regimen with which said pharmacological agent is administered.

The preferred embodiments of the present invention provides an automated system for administering a variety of known drug regimens, thus eliminating the problems associated with the manual infusion system. Because the preferred system embodiments use an intravenous bag having multiple chambers with particular configurations, the contents of the bag can only be administered in accordance with the prescribed manner.

The fluid delivery apparatus may further include a common passageway and a plurality of chamber passageways. Each chamber passageway is coupled between the common passageway and a respective chamber. The fluid delivery apparatus may also include a high pressure clip having at least first and second positions, wherein, in the first position, the clip closes the plurality of chamber passageways and, in the second position, the clip permits fluid flow through the plurality of chamber passageways. The apparatus may also include a pressure sensing dome in fluid communication with the common passageway. Further, a frangible rupture seal may be situated between at least one



chamber and the corresponding chamber passageway. Also, at least one chamber includes a sealable fill port and a sealable vent port.

The fluid delivery apparatus may further include an infusion pump with a spring driven roller for sequentially compressing the plurality of chambers. The pump may include a hinged door having a release tab. Alternatively, the infusion pump may be actuated by an

5
6
7
8
9
10
11
12
13
14
15
16
17
18
19
20
21
22
23
24
25
26
27
28
29
30
31
32
33
34
35
36
37
38
39
40
41
42
43
44
45
46
47
48
49
50
51
52
53
54
55
56
57
58
59
60
61
62
63
64
65
66
67
68
69
70
71
72
73
74
75
76
77
78
79
80
81
82
83
84
85
86
87
88
89
90
91
92
93
94
95
96
97
98
99
100



electrically driven motor for applying pressure to the chambers. The infusion pump may further include a display having status indicator lights, dose buttons, control buttons, a keypad, and a clock for controlling and
5 indicating the status of administration of an agent.

Alternatively, the infusion pump may have one or more inflatable bladders for applying pressure to the chambers. Further, a flexible bladder pad may be coupled to a series of bladders for transferring pressure from the
10 series of bladders to the chambers and locally distributing the force applied by any one of the series of bladders.

In an alternative embodiment, the invention is embodied in a fluid bag that is to be filled with pharmacological fluids associated with a desired medical
15 infusion therapy for treatment of a patient. The bag has a plurality of chambers (which typically lie substantially in a plane) for containing the pharmacological fluids. Each chamber is sized and configured to implement the desired medical therapy when the fluids are automatically infused
20 into the patient. The bag may be a unitary bag forming a cartridge.

In yet another embodiment, the invention is embodied in an automated fluid delivery apparatus for sequentially or concurrently infusing medications. The
25 apparatus includes a fluid bag which is constructed from medical grade plastic sheets that are bonded together in a manner to define a plurality of separate chambers. The

chambers lie in a plane and are configured with a respective geometry, position, and sequence for controlling the rate, volume and time of medication administration.

The invention is also embodied in a preassembled
5 and easy to use cartridge for in-home patient use that will minimize patient mistakes and the amount of time needed for training the patient. The cartridge can be inserted in a rate controlled pump that will allow the slow administration of single or multiple medicines such as
10 antibiotics or other drugs that can only be combined upon infusion.

The cartridge is constructed of two pieces that have been sealed together to form liquid containing chambers. Each chamber has a port for filling the
15 respective chambers with the desired type and volume of fluid. For the SASH procedure, for example, the chambers would normally be filled in order with Saline, Antibiotic, Saline and then Heparin. At the exit port for each chamber is a one way check valve to prevent backflow into the
20 chamber. Each chamber empties into a common dispensing line. A clamp can be used to close the dispensing line. A standard medical connector, such as a luer lock, heparin lock or needle is used to connect the cartridge to the patient's IV set or catheter.

25 Different geometric configurations of the chambers can be used for controlling and varying the rate of flow. The geometry of the chamber can also be

configured for a constant flow and to minimize the retention of residual fluid in the chamber.

In one aspect of the invention, a cartridge, with 4 chambers, is placed in a rectangular hopper. The 5 cartridge is fed through rollers and fluid is squeezed out of the cartridge through an injection line. The rollers are driven by a motor which drives a shaft that drives the rollers. A clutch is used to limit the maximum amount of force that can be applied to the rollers.

10 In an alternative embodiment of the invention, there is only one roller that is held and guided by slots to roll over the cartridge. The roller is biased by a spring to roll over the cartridge and inject the fluids in the desired sequence. This embodiment can also use a motor 15 and worm gear to drive the roller over the cartridge to dispense the fluid in the cartridge.

The features of the present invention are set forth with particularity in the appended claims. The invention will best be understood from the following 20 description when read in conjunction with the accompanying drawings.

BRIEF DESCRIPTION OF THE DRAWINGS

FIG. 1 is a plan view of a fluid bag, according to the invention, having chambers with geometries configured for implementing a medical infusion therapy.

5 FIG. 2 is a side elevation view of the fluid bag of FIG. 1.

FIG. 3 is a plan view showing a cut and weld pattern for the fluid bag of FIG. 1.

10 FIG. 4 is a top view diagram of a cartridge of the present invention.

FIGS. 5, 6, 7 and 8 are alternate configurations of the fluid reservoir.

15 FIGS. 9 and 10 are diagrams used to illustrate the method of calculating the flow rate for a particular reservoir shapes.

FIGS. 11A - 11F are schematic diagrams showing various chamber configurations, according to the invention, for the fluid bag of FIG. 1, each diagram showing a specific chamber configuration with chamber geometries
20 configured for implementing a prescribed medical infusion therapy.

FIG. 12 is a top view of another embodiment of the cartridge of the invention.

FIG. 13 is a plan view of a fluid bag having a
25 high pressure clip and a low pressure clamp pad for controlling fluid flow from the chambers.

FIGS. 14A - 14C are elevation side views of the fluid bag of FIG. 13, showing the exit port clip in its pre-installation, open, and closed positions, respectively.

FIGS. 15A - 15D are isometric views of a fluid bag, according to the invention, having an integral fluid port, pressure monitoring pad, and port clip.

FIG. 16 is an elevation view of a fluid bag, according to the invention, having frangible seals.

FIGS. 17A and 17B are perspective views of an infusion pump, according to the invention, having a chamber configured to receive the fluid bag of FIG. 1 and opposing rollers for infusing the fluids contained in the respective chambers in a prescribed sequence and rate defined by the bag chamber geometries and roller speed.

FIGS. 18A-18C are plan and side elevation views, respectively, of the infusion pump of FIGS. 17A and 17B, having an installed infusion bag.

FIGS. 19A and 19B are schematic diagrams showing control panel layouts for two embodiments of the infusion pump of FIGS. 17A and 17B.

FIG. 20 is a schematic diagram of an inflatable bladder, according to the invention, having an inflation control belt for use in an infusion pump to sequentially empty a fluid bag.

FIG. 21 is a schematic diagram of a plurality of inflatable bladders, according to the invention, for use in an infusion pump to sequentially empty a fluid bag.

FIG. 22 is a schematic diagram of a plurality of inflatable bladders, according to the invention, that act against a flexible pad for use in an infusion pump to sequentially empty a fluid bag.

5 FIG. 23 is a schematic diagram of an inflated bladder, according to the invention, for use in an infusion pump having active valves for controlling the fluid flow from each chamber to sequentially empty a fluid bag.

FIG. 24 is a diagram showing the cartridge in a
10 pump mechanism embodiment of the present invention.

FIG. 25 is a diagram showing the cartridge in an alternate pump mechanism of the present invention.

DETAILED DESCRIPTION OF THE INVENTION

15 The present invention is embodied in apparatus and related methods for automatically implementing intermittent intravenous medical therapy using a fluid bag having a configuration that largely defines the sequence and flow rate of the infusion of medications into a
20 patient. The invention is advantageous in simplifying the administration of intermittent intravenous medical infusion therapy. A patient (or caregiver), with relatively little medical training, would receive a fluid bag having chambers configured with predetermined geometries and prefilled with
25 prescribed medications and would self-administer the therapy using an infusion pump. Because the therapy is defined by the bag's configuration, the patient, nurse or

caregiver would not need to program the infusion pump or perform manual manipulations during the infusion procedure thus substantially reducing the patient's risks due to improper administration.

5 Referring to FIGS. 1 and 2, the invention is embodied in a multiple chamber fluid bag 20 or cartridge having a plurality of fluid chambers 22, 24, 26 and 28. The bag is a laminate of two flexible plastic sheets attached together to form four separate and distinct
10 chambers and corresponding passageways (not shown) from each chamber to a common passageway 30 and an exit port 31. The unitary bag is relatively flat with the chambers generally lying in a common plane. When chambers are filled with fluid, they expand to have a cylindrical or a
15 "pillow-like" shape. An infusion tube 32 is coupled to the exit port. A connector 34 is coupled to the tube for connection to standard I.V. couplers. A clip 36 is provided on the tube to stop fluid flow through the tube if needed. Although four chambers are shown in FIG. 1., as
20 will be discussed in more detail below, the fluid bag may be configured with any of a wide variety of chamber numbers, positions, sequences, and geometries. Each chamber may also include one or more fill ports 38 for filling the chambers. The bag may also include alignment
25 holes 40 (or other alignment vehicles) for positioning the bag within an infusion pump having corresponding alignment pegs (not shown).

The chambers 22, 24, 26 and 28 may be emptied by applying pressure to the bag 20. As discussed below with respect to FIGS. 24 and 25, the pressure may be applied by a roller traveling from the top of the bag toward its bottom at a steady rate. Other apparatus and methods for applying pressure to the chambers are also discussed in more detail below with respect to FIGS. 17 - 23.

The chambers of the fluid bag 20 of FIGS. 1 and 2 are suitably configured to implement a SASH infusion therapy. SASH is an acronym for Saline-Antibiotic-Saline-Heparin. The first chamber 22 is typically filled with about 5 ml. of saline solution. The second chamber 24 is typically filled with about 100 ml. of liquid antibiotic. The third and fourth chambers are each typically filled with about 5 ml. of saline solution and heparinized solution, respectively.

With reference now to FIG. 3, the bag 20 can be constructed from two flexible sheets of plastic film 44 by welding the sheets together along weld lines 46. The weld lines define each chamber's geometry and size thus its volume. The geometry and volume of each chamber defines the sequence and rate at which the corresponding prescribed medication is infused into the patient. The four alignment holes 40 may be cut before or after the sheets are welded. The plastic film may be formed of any medically acceptable

plastic, e.g., polyvinyl chloride (PVC), polyolefin or other suitable material.

The rate at which the medications exit the chambers may be additionally defined by restrictive openings at the exit of each chamber, e.g., by a restrictive orifice in the common passageway 30, by a valve in the infusion tube 32, or the like. Exit port openings for controlling the flow rate from the chambers are discussed below in more detail with respect to FIG. 9.

FIG. 4 shows a top view of a cartridge 310 of the present invention. The cartridge 310 has four chambers 312, 314, 316 and 318 for holding the SASH fluids. The first chamber 312 holds 3-10cc's of saline solution. The second chamber 314 holds 10-250cc's of the desired medicine. The third chamber 316 holds 3-10cc's of saline and the fourth chamber 318 holds 3-10cc's of heparin. The first chamber 312 is filled via port 332; the second chamber 314 is filled via port 334; the third chamber 316 is filled via port 336 and the fourth chamber 318 is filled via port 338. Ports 332, 334, 336, and 338 are standard injection ports or luer lock connections. Chambers 312, 314, 316 and 318 are supplied factory pre-filled or are pre-filled by a pharmacist with the correct fluids. After the ports are filled by the pharmacist they are sealed by the self sealing injection port or by a cap on the luer lock connection. If the chamber is factory pre-filled, it may be heat sealed after filling which would eliminate the

need for an inlet port. At the exit port of each chamber is a check valve that only permits fluid flow in one direction. Check valves 322, 324, 326 and 328 are at the exit ports of chambers 312, 314, 316 and 318, respectively. 5 Each check valve permits fluid flow into line 330 as shown in FIG. 4. Line 330 passes through clamp 340 that is used to completely restrict any fluid flow. Line 330 terminates at luer connection 342 that is used to connect to the patient catheter.

10 The cartridge 310 is constructed as a two piece laminate made from PVC, polyolefin or similar materials typically used for IV bags. The laminate is heat sealed or adhesively bonded. The cross-hatched areas 320 show the sections of the cartridge 310 that have been bonded 15 together. The unbonded areas are represented by the chambers 312, 314, 316 and 318. The chambers can be made in many different geometric shapes. These shapes can be used to control the flow rate of the medication in the chambers. This will be discussed with reference to FIGS. 9 20 and 10.

When the chambers have been filled with the desired fluids, the cartridge 310 is placed in the pump unit, not shown in FIG. 4, for infusion of the medication.

Rollers will squeeze the fluids in sequence from chambers 25 312, 314, 316 and 318 into the line 330, past the clamp 340 to luer connection 342 and into the patient catheter. When the infusion sequence is completed, the cartridge can be

disconnected from the catheter and pump and then discarded. This infusion process does not involve the use of needles or syringes and therefor increases the safety factor for anyone administering the procedure. The fluid dynamics of
5 the dispensing process will now be discussed with reference to FIGS. 5 - 10.

FIGS. 5, 6, 7 and 8 show alternate geometric shapes for the fluid chambers discussed with reference to FIG. 4. FIG. 5 shows a fluid chamber 350 having a filling
10 port 356 and an exit port 352. As fluid chamber 350 is compressed by the pumping device, to be discussed later, the fluid is expelled from the chamber 350 through the exit port 352. The shape of chamber 350 can provide a higher fluid flow rate in the beginning and a steadily decreasing
15 flow rate until all the fluid has been dispensed. The fluid flow rate will be discussed in greater detail with reference to FIGS. 9 and 10. FIG. 6 shows fluid chamber 354, filling port 358 and exit port 355. The shape of this fluid chamber can provide a constant fluid flow rate from
20 the beginning to the end of the infusion. FIG. 7 shows fluid chamber 360 with filling port 64 and exit port 362. The shape shown in FIG. 7 can provide a nonlinear decrease in the flow rate from the beginning to the end of the infusion. FIG. 8 shows fluid chamber 366 having filling
25 port 368 and exit port 365. The shape shown in FIG. 8 can provide an initially constant fluid flow rate followed by a steadily decreasing flow rate during the last part of the

infusion. The factors involved in determining the fluid flow rate will now be discussed with reference to FIGS. 9 and 10.

FIG. 9 shows a fluid chamber 370 having an exit port 372. The exit port 372 has a length represented by L and a radius represented by R. P_1 represents the pressure inside the fluid chamber 370 and P_2 represents the pressure outside the fluid chamber 370. In the following formula Q represents the Mass Flow Rate in ml/min and μ represents the viscosity of the fluid in the fluid chamber 370. The formula is as follows:

$$Q = \pi R^4 (P_1 - P_2) / 8 L \mu$$

The above equation is Poiseville's Law for Homogeneous Fluid. $P_1 - P_2$ is the difference in pressure between the inside and the outside of the fluid chamber 370. A change in the radius R of the exit port 372 or a change in the length L of the exit port 372 can have a large effect on the flow rate Q. The elasticity of the materials used to construct the fluid chamber can also have an effect on the flow rate. However, for the purpose of this discussion it is assumed that the elasticity will not have a significant effect on the flow rate.

FIG. 10 shows a fluid chamber 380 having an exit port 386. If it is assumed that the R and L are constant, then the major factor in determining the flow rate will be P_1 . If a press type roller moving at a constant rate starts to compress the fluid chamber 380 at point 388 then the

pressure P_1 will continually increase. Thus the pressure generated at line 384 will be much greater than the pressure generated at line 382, causing a much higher flow rate at line 384. FIG. 10 shows a fluid chamber that can have an increasing flow rate from the beginning to the end of the infusion.

Differing infusion therapies for a wide variety drug regimens may be implemented by the chamber configurations as shown, for example, in FIGS. 11A - 11F.

10 For example, as shown, in FIG. 11A the infusion bag 20 is configured with four separate fluid chambers 22, 24, 26 and 28 suitable for implementing a SASH drug regimen. The intravenous antibiotic is contained in the second chamber 24. The volume and shape of the second chamber may be

15 prescribed to affect the volume and the administration rate of the antibiotic as shown in FIGS. 11A - 11C. In FIG. 11A, the antibiotic chamber 24 has a square shape and a volume of about 100 ml. In FIG. 11B, the antibiotic chamber 24 has an elongated rectangular shape and a volume

20 of about 50 ml. The antibiotic chamber 24 shown in FIG. 11C, also has a volume of 50 ml, but has a wide shortened rectangular shape. Accordingly, using a constant speed roller that compresses the chambers from top to bottom, the drug prescribed by the bag in FIG. 11B is infused at a

25 slower rate than the drug prescribed by the bag in FIG. 11C. The chamber, of course, is not required to have a rectangular shape and, thus, it may have any shape (e.g.,

circular, triangular, diamond, etc.) which is beneficial for administering a prescribed infusion therapy.

Further, drugs that are incompatible for pre-mixing may be stored in separate chambers until they are
5 simultaneously infused into the patient. As shown in FIG. 11D, simultaneous infusion of separate drugs may be readily accomplished by configuring the bag 48 to have two side-by-side chambers 50 and 52. The first chamber 50 is filled with a first drug and the second chamber 52 is
10 filled with a second drug. Accordingly, as the roller travels down the bag, it simultaneously compresses the two side-by-side drug chambers so that the two drugs are simultaneously infused into the patient, thus simplifying the infusion of the two incompatible drugs without pre-
15 mixing.

As shown in FIG. 11E, the infusion therapies that may be addressed by configuring the bag's geometry are not limited to the SASH procedure. The bag in FIG. 11E is configured with six separate chambers. The first, third
20 and fifth chambers 56, 58 and 60 can be filled with a saline solution and the sixth chamber 62 can be filled with Heparin. The second and fourth chambers 64 and 66, however, can be filled with first and second drugs, respectively. Of course, this bag may be used to
25 administer intermittent infusions of a single drug by filling the second and fourth chambers with the same drug.

Similarly, as shown in FIG. 11F, multiple doses of a drug may be intermittently administered at prescribed time intervals by a bag 70 having its chambers configured in accordance with the dosage regimen. Thus, the first 5 chamber 72 can be filled with a first prescribed drug dosage, the second chamber 74 can be filled with a saline solution, the third chamber 76 can be filled with a second prescribed drug dosage, the fourth chamber 78 can be filled with a saline solution, the fifth chamber 80 can be filled 10 with a third described drug dosage, and finally, the sixth chamber 82 can be filled with a final saline solution.

FIG. 12 shows a cartridge 440 having six fluid chambers 454, 456, 458, 460, 462 and 464. Each fluid chamber has its respective check valve 468, 470, 472, 474, 15 476 and 478 in its respective exit port. Each of the fluid chambers 454, 456, 458, 460, 462 and 464 is filled via its respective filling port 442, 444, 446, 450, 448 and 452 as previously described. The exit port for each fluid chamber empties into line 466 causing the fluid in the chambers to 20 pass along line 466 through clamp 480 to luer connector 482. The connector 482 can be any type of connector required for the environment in which the cartridge 440 is used. Fluid chamber 454 could be used to deliver saline as previously discussed. Chambers 456, 458, 460 and 462 would 25 be used to deliver medications concurrently to the patient. For instance, fluid chambers 456 and 458 will deliver the medications concurrently with both chambers starting

delivery and ending delivery of the medication at the same time. Fluid chamber 462 will start its delivery after fluid chambers 456 and 458 start their delivery and fluid chamber 462 will end its delivery of medication after fluid chambers 456 and 458 end their delivery. Fluid chamber 460 will begin its delivery of medication before fluid chambers 456, 458 and 462 deliver their medication and fluid chamber 460 will end its delivery of medication after fluid chambers 456, 458 and 462 end their delivery of medication.

10 This arrangement allows the flexibility of delivering medications simultaneously or in any sequence desired. This is useful when medications that cannot be premixed are to be delivered simultaneously. In another sequence, fluid chamber 460 can be filled with saline that can be delivered

15 simultaneously with and after the medications that are delivered from the fluid chambers 456, 458 and 462. Fluid chamber 464 could then contain heparin as previously discussed. The cross-hatched areas 484 show the sections of the cartridge 440 that have been bonded together. This

20 arrangement shows the flexibility of the invention as well as the simplicity of the invention that allows for the uncomplicated administration of medications to a patient.

Intermittent medications are prescribed using widely accepted medical infusion therapies that are fairly

25 standard for adult patients with similar diagnoses. These standard medical therapies often call for multiple administrations of an infusion regimen each day and rarely

change after they are prescribed. Thus a prescription for an infusion regimen is similar to a prescription for an oral antibiotic in that the drug is taken a predetermined number of times per day for a predetermined time period.

5 Accordingly, an infusion patient generally receives a prescription for a particular medical infusion therapy that remains the same for several days. In accordance with the invention, the infusion prescription is filled by a pharmacist having a supply of infusion bags 20 having

10 chambers with differing configurations. The pharmacist would provide the patient with the prescribed number of prefilled bags with the prescribed medication dosages.

The following list is illustrative of the types of drug regimens that may be implemented in a bag in

15 accordance with the invention. Possible drug regimens and possible chamber configurations are not limited to those listed below or shown in the drawings.

PARTIAL LIST OF EXAMPLE DRUG REGIMENS

20 Antibiotics

- 1)
 - 5 ml of 0.9% Saline -- given quickly or over a few minutes;
 - 25
 - 1 gram (g) of Cefazolin in 50ml of 5% Dextrose in Water -- given over 60 minutes; and
 - 5 ml of 0.9% Saline -- given quickly or over a few minutes.
 - 30 2)
 - 3 ml of 0.9% Saline -- given quickly or over a few minutes;
-

- 1 g of Cefazolin in 20ml of Dextrose (D5W) -- given over 30 minutes;
- 3 ml of 0.9% Saline -- given quickly or over a few minute;
- 5 • 1 g of Ceftazidime in 20 ml of Dextrose (D5W) -- given over 30 minutes;
- 3 ml of 0.9% Saline -- given quickly or over a few minutes; and
- 10 • 5 ml of 1000 units/mL of Heparized Saline -- given quickly or over a few minutes.
- 3)
- 5 ml of 0.9% Saline -- given quickly or over a few minutes;
- 15 • 80mg of Gentamicin in 50 ml of 0.9% Saline -- given over 60 minutes;
- 5 ml of 0.9% Saline -- given quickly or over a few minutes;
- 20 • 500mg of Ampicillin in 100 ml of 0.9% Saline -- given over 60 minutes;
- 5 mls of 0.9% Saline -- given quickly or over a few minutes; and
- 5 ml of 100 units/ml of Heparized Saline -- given quickly or over a few minutes.
- 25
- 4)
- 10 ml of 0.9% Saline -- given quickly or over a few minutes;
- 30 • 1 g of Vancomycin in 250ml of 0.9% Saline -- given over 90 minutes; and
- 10 ml of 0.9% Saline -- given quickly or over a few minutes.
- 35 5)
- 3 ml of 0.9% Saline -- given quickly or over a few minutes;
- 1 g of Cefazolin in 20ml of Dextrose (D5W) -- given over 30 minutes;
- 40 • 80 mg of Gentamicin in 50 ml of 0.9% Saline -- given over 60 minutes;
- 1 g of Ceptazidime in 100 ml of 0.9% Saline -- given over 60 minutes; and

- 5 ml of 0.9% Saline -- given quickly or over a few minutes.
- 6)
- 5
- 500 mg of Cafazolin in 20ml of Dextrose (D5W) -- given over 30 minutes;
 - 500 mg of Ceptazidime in 20 ml of 0.9% Saline -- given over 60 minutes; and
 - 50 mg of Tobramycin in 50 ml of 0.9% Saline --
- 10
- given over 60 minutes.

Anti-Emetic (Nausea) Therapy and Chemotherapy

- 1)
- 15
- 100 ml of 0.9% Saline given over 30 minutes;
 - Kytril in 20 ml of 0.9% Saline given over five minutes; and
 - Cisplatin in 100 ml of 0.9% Saline given over 30 minutes.
- 20

Chemotherapy

- 1)
- 25
- 5 ml of 0.9% Saline -- given quickly or over a few minutes;
 - 25 ml of Cyclophosphamide -- given over 30 minutes;
 - 25 ml of Doxorubicin -- given over 5 minutes;
 - 25 ml of 5-FU -- given over 10 minutes; and
- 30
- 5 ml of 0.9% Saline -- given quickly or over a few minutes.
- 2)
- 35
- 10 ml of 0.9% Saline -- given quickly or over a few minutes;
 - 10 ml of Vincristine -- given over five minutes; and
 - 10 ml of 0.9% Saline -- given quickly or over a few minutes.
- 40
- 3)
- 5 ml of 0.9% Saline -- given quickly or over a few minutes;
 - 10 ml of 5-FU -- given over 10 minutes;

- 5 ml of 0.9% Saline -- given quickly or over a few minutes; and
- 5 ml of 100 units/mL of Heparized Saline -- given quickly or over a few minutes.

5

Other (Biotechnology Drugs)

1)

- 5 ml of 0.9% Saline -- given quickly or over a few minutes;
- 30 ml of Drug #1 -- given over 60 minutes;
- 10 ml of Drug #2 -- given over 20 minutes; and
- 5 ml of 0.9% Saline -- given quickly or over a few minutes.

15

2)

- 5 ml of 0.9% Saline -- given quickly or over a few minutes;
- 30 ml of Drug #1 -- given over 60 minutes;
- 5 ml of 0.9% Saline -- given quickly or over a few minutes;
- 10 ml of Drug #2 -- given over 20 minutes; and
- 5 ml of 0.9% Saline -- given quickly or over a few minutes.

25

3)

- 5 ml of 0.9% Saline -- given quickly or over a few minutes;
- 60 ml of Drug #1 -- given over 60 minutes tapered linearly beginning at a rate of 10 ml/hr and ending at a rate of 110 ml/hr.;
- 15 ml. of Drug #2 -- given over 30 minutes; and
- 5 ml of 0.9% Saline -- given quickly or over a few minutes.

35

Another embodiment of a fluid bag 90, in accordance with the invention, is shown in FIGS. 13, 14A, 14B and 14C. In this embodiment, the fluid bag includes a high-pressure clip 92 that is completely closed when the bag 40 is in transport, preventing fluid from leaking from the

bag or from moving between chambers. The clip includes a first bar 94 having two notched prongs 96, and a second bar 98 having two corresponding sockets 100 for receiving the prongs. The bars may also include alignment holes 107 for specifically aligning the clip in the pump. The clip may be formed of metal or relatively rigid plastic and the two bars may be attached by a small wire or flexible plastic strip 101. The prongs each have a dual position latch 102 which engages a ledge 104 in the socket. After the clip is closed to the second latch position, it closes the passage ways (see FIG. 14C) and cannot be opened with reasonable manual effort. The clip is engaged on the bag over the chamber passageways 108, 110, 112 and 114 through two clip holes 106 in the bag. The clip is automatically released and opened only when the bag is placed in an infusion pump of the invention, and the pump's door is properly closed, the latch is automatically opened by the pump to a first open position (see FIG. 14B).

In this embodiment, the pump also includes a low-pressure clamp. When the bag is properly placed in the pump and the door is properly closed, the low-pressure clamp or pad of the pumping device lays parallel next to the clip and seals off the chamber passageways 108, 110, 112 and 114 at a pad location 115 and simultaneously the clip is opened. The low-pressure clamp generates sufficient pressure to prevent any fluid flow through the chamber passageways until a minimum of pressure is applied

to the chambers by the pump. When the pump generates enough pressure within a chamber, the fluid in the chamber is forced underneath and past the clamp through the corresponding chamber passageway to a common passage 116
5 which leads to the outlet port 118. The bag may also include a pressure sensing dome 120 which is fluidly coupled to the common passage. The pressure sensing dome may be used to provide occlusion detection or pressure control. The pump pressurizes the bag in a linear sequence
10 from the bag's top to its bottom. Again, because each chamber's size and shape governs how the contents of each respective chamber will be administered, the bag may be configured to match the designed drug regimen.

In this embodiment, the bag's chambers can be
15 filled with its base solutions (diluent) through the outlet (and fill) port 108 in the following manner. The high pressure clip 92 is released either by a special filling device which automatically releases the clip as the proper solution(s) are flowing into the bag or by a specially
20 designed hand release device. Additionally, the bag may include filling ports for each chamber (not shown, see e.g., FIG. 1) and fluids or drugs may be added through these filling ports on an opposite side of the bag.

FIGS. 15A-15D show another embodiment of a fluid
25 bag 122 of the present invention. The bag is shown with four chambers 22, 24, 26 and 28 for implementing the SASH infusion procedure. In this embodiment, the bag includes

an integral connector 124 for coupling to an infusion tube (not shown). The integral connector allows the bag to be more integrated and simplifies the procedure for inserting the bag into an infusion pump. The bag further includes 5 associated passageways 108, 110, 112 and 114 from each chamber to a common passageway 116 leading to the connector, a high pressure clip 92, five alignment holes 40, and a pressure sensing dome 120. These components function as described in the previous embodiment shown in 10 FIGS. 13 and 14A-14C.

FIG. 16 shows another embodiment of a fluid bag of the invention. The bag 130 has features that are similar to the features of the bags discussed above and further includes fill openings 132, vent openings 134 and 15 frangible rupture seals 136. Thus, each of the chambers 22, 24, 26 and 28 has a fill opening 132 and a vent opening 134. The vent part for the drug chamber 24 also includes a resealable or reusable port 138 for adding medication to the chamber.

20 In this embodiment, the chambers are filled with the prescribed fluids through the fill openings 132. Air is allowed to escape through the vent openings 134 to prevent air bubbles in the chambers. Then all of the openings, except the opening to the additional drug port 25 138, may be sealed along seal lines 140 and 142 by a heat or ultrasonic seal or the like. An additional seal may seal the drug chamber 24. The seal prevents the addition

of additional drugs to the respective sealed chambers. The bag also features frangible rupture seals. As pressure is sequentially applied to the second, third and fourth chambers, respectively, the seal ruptures when the pressure 5 in the corresponding chamber exceeds a predetermined threshold value. Alternatively, the rupture seals may break at incremental increases in the applied chamber pressure such that when increasing pressure is applied to the entire surface of the bag, the rupture seals define the 10 sequence of administration of the fluids in the chambers.

The fluid bag of the invention may be filled by the bag manufacturer or by a pharmacist. The manufacturer may fill the bag's chambers with saline solution, with other base solutions, or with the appropriate medications 15 in a "form, fill and seal" or other manufacturing process. Alternatively, the manufacturer may leave one or more chambers empty. The pharmacist would then complete the prescription using the fill ports. In yet another alternative, medication may be added to a bag through the 20 fill port after the bag is inserted into a pump.

The techniques for applying pressure to the bag may include a linear roller mechanism, a coiled spring mechanism, an air bladder, a series of platens, or other alternative methods. The pressurization technique is chosen 25 in accordance with the designed embodiment of the bag and may be effected by a mechanical, electrical, chemical or other drive means, alone or in combination. Apparatus for

implementing representative pressurization techniques are discussed below.

FIGS. 17A and 17B show an embodiment of an infusion pump 150 for expelling the fluids from the chambers 22, 24, 26 and 28 of a fluid bag 152 of the invention. The infusion pump has compartment 154 for receiving the fluid bag. The compartment has a hinged door 156 which is shown in its open position in FIG. 17A. The hinged door includes a release latch 158. At one end of the chamber are a roll-up roller 160 and an opposing roller 162. The roll-up roller travels at a constant speed in conjunction with the opposing roller so that the rollers travel the length of the bag to sequentially compress the bag and sequentially force the fluid from the chambers toward the exit ports. The roll-up roller can be driven by a variety of means, e.g., a spring drive mechanism housed in the enlarged side portion 163 of the pump which also functions as a hand grip. The hand grip is preferably covered with a "soft feel" material. The fluid bag shown in FIG. 17A has three exit ports 164, 166 and 168 that are coupled to an injection molded manifold 170 that functions as fill ports for the chambers and includes check valves. The solutions from the separate chambers are coupled to an exit tube 172.

The infusion pump 150 may have status indicators 174 for indicating the progress of the infusion. The pump may be an entirely mechanical device that may be operated

by a spring mechanism. The pump may have a curved back surface 176 for ergonomically fitting against a patient's body.

FIGS. 18A-18C show another infusion pump 177 having an installed fluid bag for administering the SASH infusion procedure. This embodiment of the pump includes electronic control circuits and mechanisms for programmable control of the roller mechanism. Programmable control allows the roller mechanism to operate at a variable rate. Further, the roller mechanism may be stopped between chambers for a desired time interval.

FIG. 19A shows a control panel 178 for one embodiment of the infusion pump 177 of FIGS. 18A-18B. The pump's control panel has three buttons and four lights. The first button 180 is a start or run button for beginning the infusion procedure. The next button 182 is a stop or pause button to interrupt the infusion for a relatively brief pause. The third button 184 is a discontinue dose button for terminating the infusion. The lights indicate the status of an infusion and may be light emitting diodes, incandescent lamps, or the like. After the start or run button has been pressed and the roller is sequentially compressing the bag's compartments, the running light 186 will be lit. If the pause button is pressed during the infusion procedure, the stopped/pause light 188 will be lit. When the infusion has been completed, the bag empty light 190 will be lit. An additional light 192 indicates

whether an occlusion has occurred in the infusion line leading to the patient.

FIG. 19B shows a control panel 178 for a second embodiment of the infusion pump 177 of FIGS. 18A-18C. The panel further includes, in addition to the buttons discussed above with respect to FIG. 19A, a clock 192, a keypad 194, and three dose select buttons 196. The keypad may be used to enter a prescribed infusion therapy. The dosage buttons may be used to select various dose rates or administration times for a given bag (or times for given chambers within a bag) and corresponding drug therapy.

Another embodiment of the infusion pump mechanism for applying pressure sequentially across a bag 20 of the invention is shown in FIG. 20. The bag rests on a relatively rigid surface 200. A pressurized bladder 202 is separated from the bag by a movable belt 204. The bladder is sequentially released by the belt, thus applying sequential pressure across the bag. The belt accordingly replaces, for example, the function of the roller in the infusion pump of FIGS. 17A and 17B. The speed at which the belt releases the bladder controls the pumping speed of the infusion pump.

Yet another embodiment of the infusion pump pressure mechanism is shown in FIG. 21. Pressure is applied to the bag 20 by a series of inflatable bladders 206. The bladders are inflated sequentially so that the series of bladders perform the same function as the rollers

shown in FIGS. 17A and 17B. A timer or a pressure sensor feedback mechanism (not shown) initiates the inflation of each subsequent bladder of the series of the desired time.

Another embodiment of the infusion pump pressure mechanism is shown in FIG. 22. The mechanism includes a series of bladders 206 that press a flexible pad 208 against the bag. The bladders are inflated sequentially and the flexible pad operates to smooth out pressure variations caused by the inflation of each individual bladder.

An additional embodiment of the infusion pump, shown in FIG. 23, has a single bladder 210 that is pressurized after the bag is installed in the pump. The pump further includes valves configured to press against the respective passages of the chambers. The flow rate and sequence of fluids flowing from the chambers may be controlled by the valves, the applied pressure, and restrictive orifices to actively control the infusion process.

FIG. 24 shows a pump cartridge 410 inside one embodiment of a pump 400. In this embodiment of the invention there is only one roller 402 that is held and guided by two slots 404 (only one slot is shown) to roll over the cartridge 410. The roller is biased by a spring 406 to roll over the cartridge 410 and expel the fluids via exit port 408. This embodiment can also use a motor and worm gear to drive the roller 402 over the cartridge 410 to

dispense the fluid in the cartridge. The force applied to the roller by the motor and worm gear is controlled to produce the desired Q for any given R, L and chamber geometry. FIG. 24 shows the fluid chamber 409 having a top curved wall 407 and a relatively flat bottom wall 411. However, depending on the materials used, both the top wall 407 and the bottom wall 411 can be curved, thus making a relatively symmetrical fluid chamber.

FIG. 25 shows one aspect of the invention in which a cartridge 414 with four chambers is placed in a vertically oriented rectangular hopper 412. as the cartridge 414' is fed through the rollers 418 and 420, fluid is squeezed out of the cartridge 414 through line 408. The rollers are driven by motor 428 via shaft 426 to clutch 424 which drives the shaft 422 that drives the rollers 418 and 420. The clutch 424 is used to limit the maximum amount of force that can be applied to the rollers. The roller 418 is shown with optional tractor feed teeth 416 that can engage corresponding holes in the cartridge 414 for the purpose of applying a consistent force to the cartridge and preventing slippage of the cartridge when engaged by the rollers.

While the foregoing has been with reference to specific embodiments of the invention, it will be appreciated by those skilled in the art that these are illustrations only and that changes in these embodiments can be made without departing from the principles of the

invention, the scope of which is defined by the appended
claims.

What is claimed is:

1. A fluid delivery apparatus for the automated sequential or concurrent infusion of a plurality of pharmacological agents, said apparatus comprising a plurality of chambers each configured with
5 a respective geometry, wherein each chamber configuration controls the volume of each pharmacological agent administered, the rate at which each pharmacological agent is administered, and the regimen with which said pharmacological agent is
10 administered.

2. A fluid delivery apparatus as defined in claim 1, further comprising:
a common passageway; and
15 a plurality of chamber passageways, each chamber passageway being coupled between the common passageway and a respective chamber.

3. A fluid delivery apparatus as defined in
20 claim 2, further comprising a high pressure clip having at least first and second positions, wherein, in the first position, the clip closes the plurality of chamber passageways, and in the second position, the clip permits fluid flow through the plurality of chamber passageways.
25

4. A fluid delivery apparatus as defined in claim 3, wherein the high pressure clip comprises first and second bars, the first bar has two double notched prongs and the second bar has two sockets, each socket having a ledge for engaging a respective notched prong.

5. A fluid delivery apparatus as defined in claim 4, wherein the first and second bars are coupled by a small flexible plastic strip.

10

6. A fluid delivery apparatus as defined in claim 2, further comprising a pressure sensing dome in fluid communication with the common passageway.

15

7. A fluid delivery apparatus as defined in claim 2, wherein the common passageway is coupled to an outlet port.

8. A fluid delivery apparatus as defined in claim 2, wherein the common passageway is coupled to an integral connector.

9. A fluid delivery apparatus as defined in claim 2, further comprising a frangible rupture seal between at least one chamber and the corresponding chamber passageway.

25

10. A fluid delivery apparatus as defined in claim 1, wherein at least one chamber includes a sealable fill port and a sealable vent port.

5 11. A fluid delivery apparatus as defined in claim 1, wherein at least one chamber includes a resealable port.

12. A fluid delivery apparatus as defined in
10 claim 1, further comprising an infusion pump with a spring driven roller for sequentially compressing the plurality of chambers.

13. A fluid delivery apparatus as defined in
15 claim 12, wherein the pump includes a hinged door having a release tab.

14. A fluid delivery apparatus as defined in claim 1, further comprising an infusion pump actuated by an
20 electrically driven motor for applying pressure to the chambers.

15. A fluid delivery apparatus as defined in claim 14, wherein the pump includes a display having status
25 indicator lights, dose buttons, control buttons, a keypad, and a clock for controlling and indicating the status of an agent administration.

16. A fluid delivery apparatus as defined in claim 1, further comprising an infusion pump having an inflatable bladder for applying pressure to the chambers.

5

17. A fluid delivery apparatus as defined in claim 16, wherein the pump includes a belt for sequentially releasing the bladder for applying pressure to the chambers.

10

18. A fluid delivery apparatus as defined in claim 16, wherein the pump bladder includes a series of sequentially inflatable bladders for sequentially applying pressure to the chambers.

15

19. A fluid delivery apparatus as defined in claim 18, further comprising a flexible bladder pad coupled to the series of bladders for transferring pressure from the series of bladders to the chambers and locally
20 distributing the force applied by any one of the series of bladders.

20. A fluid delivery apparatus as defined in claim 16, further comprising valves that are controllably
25 opened to determine the sequence by which the agents are administered.

21. A fluid delivery apparatus as defined in claim 1, wherein the chambers are configured to sequentially administer the agents.

22. A fluid delivery apparatus as defined in claim 1, wherein the chambers are configured to concurrently administer at least two of the agents.

5 23. A fluid delivery apparatus as defined in claim 1, wherein each chamber's size and shape controls the rate, volume, and time the agents are administered.

24. A fluid delivery apparatus as defined in claim 1 wherein each chamber's position controls time the agents are administered.

10 25. A fluid delivery apparatus as defined in claim 1, wherein said bag is constructed from medical grade plastic sheets bonded together to define said plurality of chambers, and wherein said plurality of chambers lie substantially in a single plane.

26. A fluid delivery apparatus as defined in claim 25, wherein the rate of fluid flow from the chambers is controlled by an orifice.

15 27. A fluid delivery apparatus as defined in claim 1, wherein said plurality of chambers each connect to a common tube via a fluid exit path, said plurality of chambers provide sequential automatic delivery of fluids, at least one of said chambers comprises a back-flow prevention device disposed between said chamber and said common tube, at least one of said chambers comprises a resealable filling port, and at least one of said chambers comprises an exit path having a length and radius for
20 controlling flow of fluid from said fluid chamber when a pressure is generated within said fluid chamber.

28. The fluid delivery apparatus of claim 27 wherein:
each fluid chamber has a back flow prevention device disposed between said fluid chamber and said common tube to prevent back flow into said fluid chamber,
25 the second chamber in the sequence having said resealable filling port, and said length and radius for controlling flow of fluid from said fluid chamber is located in said common tube.

29. The fluid delivery apparatus of claim 27 wherein:
the physical relationship between at least one fluid chamber and its exit path
30 facilitates delivery of nearly all the fluid contained in said fluid chamber.

30. The fluid fluid delivery apparatus of claim 27 wherein:
the geometry of at least one fluid chamber is used to control the rate of fluid flow from that fluid chamber.



31. A fluid delivery apparatus as defined in claim 27, comprising four fluid chambers arranged substantially in a single plane for sequential automatic delivery of fluids.

32. The fluid delivery apparatus of claim 31 wherein:
 5 each fluid chamber has a back flow prevention device disposed between said fluid chamber and said common tube to prevent back flow into said fluid chamber, the second chamber in the sequence has a resealable filling port, and said length and radius for controlling flow of fluid from said fluid chamber is located in said common tube.

33. The fluid delivery apparatus of claim 31 wherein:
 10 the physical relationship between at least one fluid chamber and its exit path facilitates delivery of nearly all the fluid contained in said fluid chamber.

34. The fluid delivery apparatus of claim 31 wherein:
 15 the geometry of at least one fluid chamber is used to control the rate of fluid flow from that fluid chamber.

35. The fluid delivery apparatus of claim 31 wherein:
 the first chamber in the sequence is adapted to deliver saline, the second chamber in the sequence is adapted to deliver a medication, a third chamber in the sequence is adapted to deliver saline and a fourth chamber in the sequence is adapted to deliver
 20 heparinized solution.

36. A fluid delivery apparatus as defined in claim 27, comprising at least four fluid chambers arranged substantially in a single plane for sequential automatic delivery of fluids.

37. The fluid delivery apparatus of claim 36 wherein:
 25 the chambers not having a resealable filling port are adapted to be pre-filled.

38. The fluid delivery apparatus of claim 36 wherein:
 the second and third chambers have a filling port having a resealing means and the remainder of the chambers are adapted to be pre-filled.

39. The fluid delivery apparatus of claim 36 wherein:
 30 the physical relationship between the at least one fluid chamber and its fluid exit path facilitates delivery of nearly all the fluid contained in said fluid chamber.

40. The fluid delivery apparatus of claim 36 wherein:
 the geometry of at least one fluid chamber is used to control the rate of fluid flow from that fluid chamber.

41. The fluid delivery apparatus of claim 36 wherein:



the first chamber in the sequence is adapted to deliver saline, the second and third chambers in the sequence are adapted to deliver a medication and the fourth chamber in the sequence is adapted to deliver saline.

42. The fluid delivery apparatus of claim 36 including:

5 a fifth chamber in the sequence that is adapted to deliver heparinized solution.

43. A fluid delivery apparatus as defined in claim 1, further comprising a pump means configured to automatically and sequentially discharge fluid from each of said chambers.

44. The fluid delivery apparatus of claim 43 wherein:

10 each fluid chamber has a back flow prevention device disposed between said fluid chamber and said common tube to prevent back flow into said fluid chamber, the second chamber in the sequence having said resealable filling port, and said length and radius for controlling flow of fluid from said fluid chamber is located in said common tube.

45. The fluid delivery apparatus of claim 43 wherein:

15 the physical relationship between at least one fluid chamber and its exit path facilitates delivery of nearly all the fluid contained in said fluid chamber.

46. The fluid delivery apparatus of claim 43 wherein:

20 the geometry of at least one fluid chamber is used to control the rate of fluid flow from that fluid chamber.

47. A fluid delivery apparatus as defined in claim 27, further comprising a pump means configured to automatically and sequentially discharge fluid from each of said chambers.

48. The fluid delivery apparatus of claim 47 wherein:

25 the chambers not having a resealable filling port are adapted to be pre-filled.

49. The fluid delivery apparatus of claim 47 wherein:

30 each fluid chamber has a back flow prevention device disposed between said fluid chamber and said common tube to prevent back flow into said fluid chamber, the second chamber in the sequence having said resealable filling port, and said length and radius for controlling flow of fluid from said fluid chamber is located in said common tube.

50. The fluid delivery apparatus of claim 47 wherein:

the physical relationship between at least one fluid chamber and its exit path facilitates delivery of nearly all the fluid contained in said fluid chamber.

51. The fluid delivery apparatus of claim 47 wherein:



the geometry of at least one fluid chamber is used to control the rate of fluid flow from that fluid chamber.

52. A fluid delivery apparatus substantially as hereinbefore described with reference to any one of the embodiments of the invention shown in the accompanying
5 drawings.

Dated 22 March, 2002
Tandem Medical
Patent Attorneys for the Applicant/Nominated Person
SPRUSON & FERGUSON

52

52



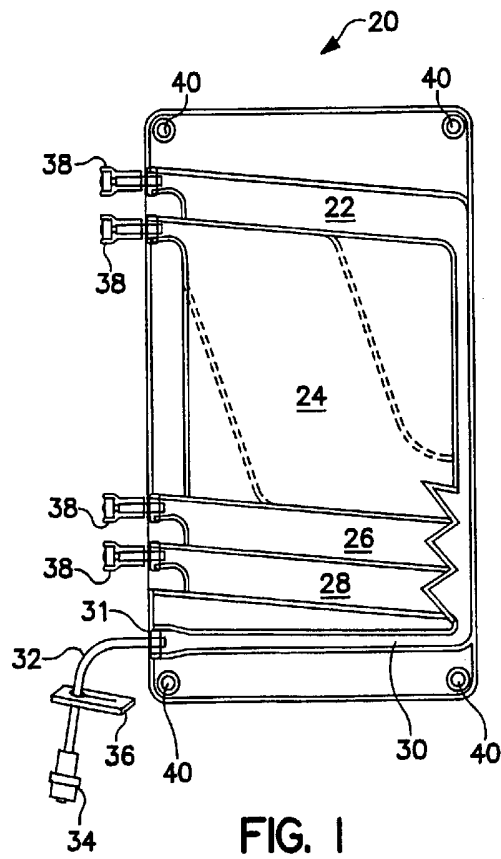

FIG. 1

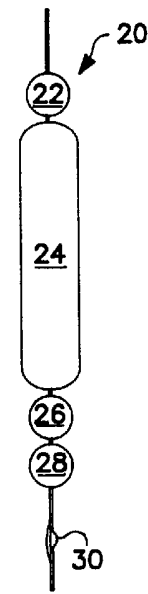

FIG. 2

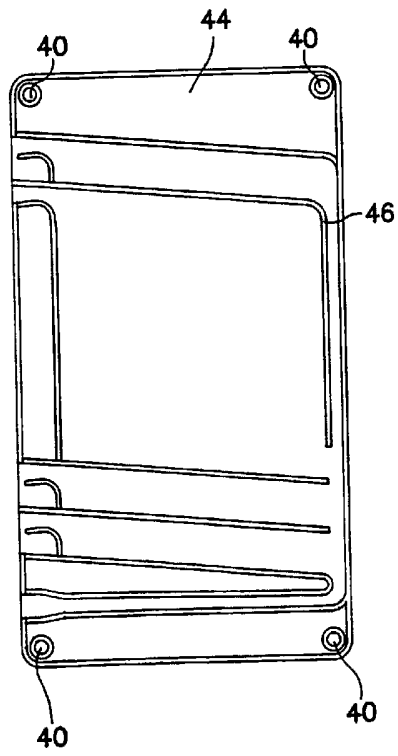

FIG. 3

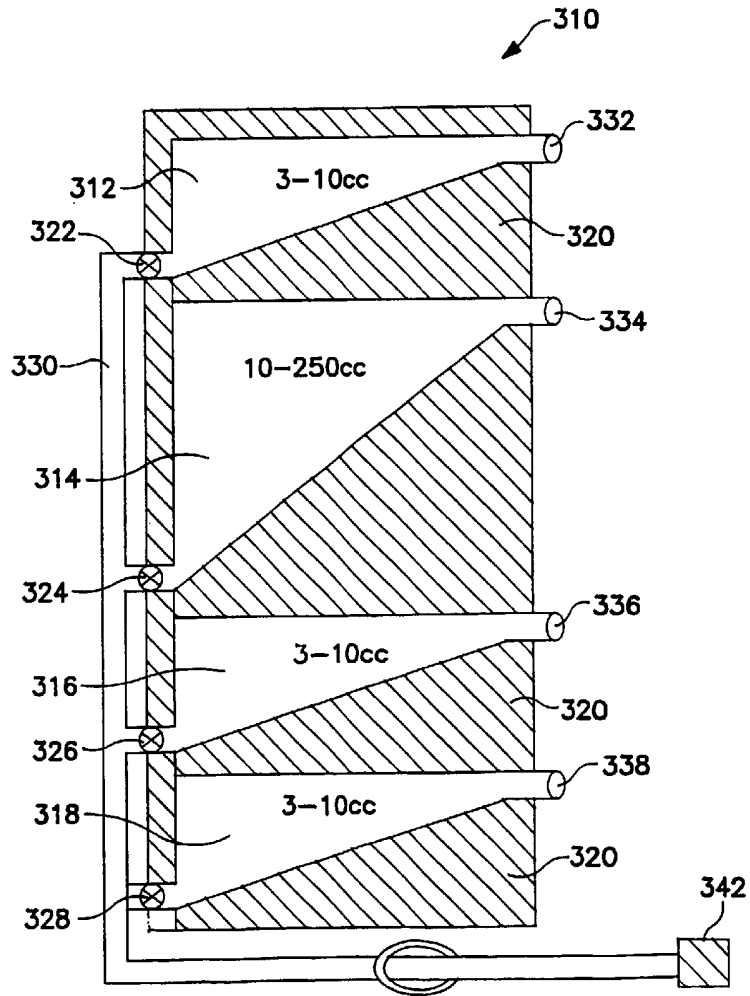

FIG. 4

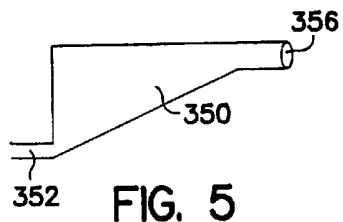

FIG. 5

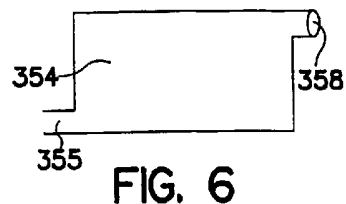

FIG. 6

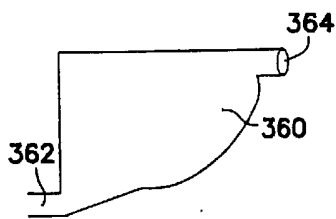

FIG. 7

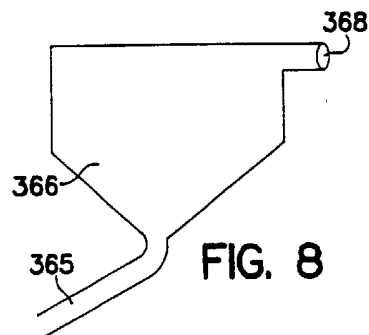

FIG. 8

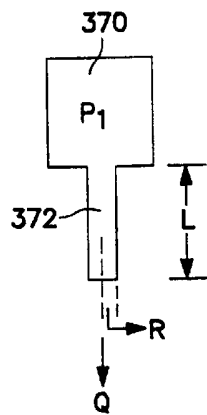

FIG. 9

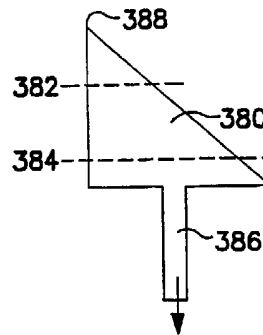

FIG. 10

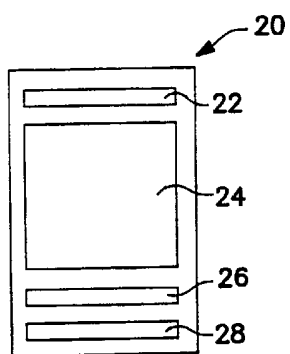

FIG. IIA

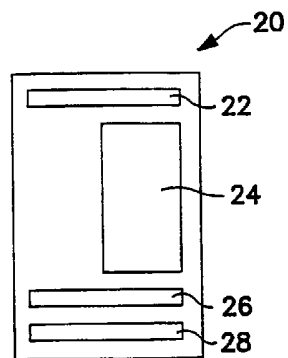

FIG. IIB

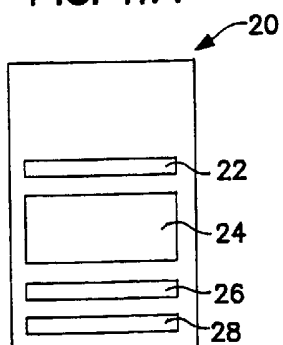

FIG. IIC

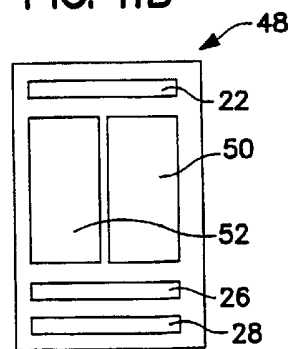

FIG. IID

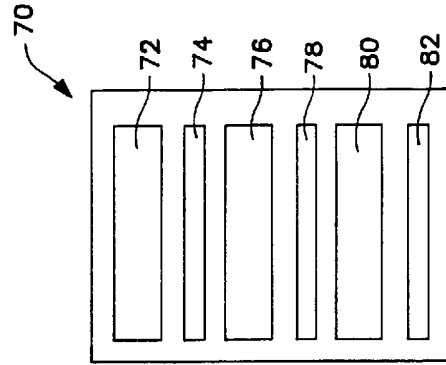

FIG. IIF

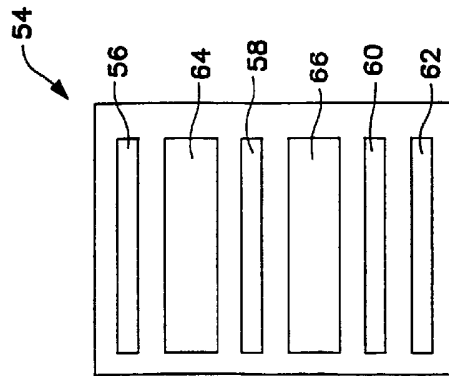

FIG. IIE

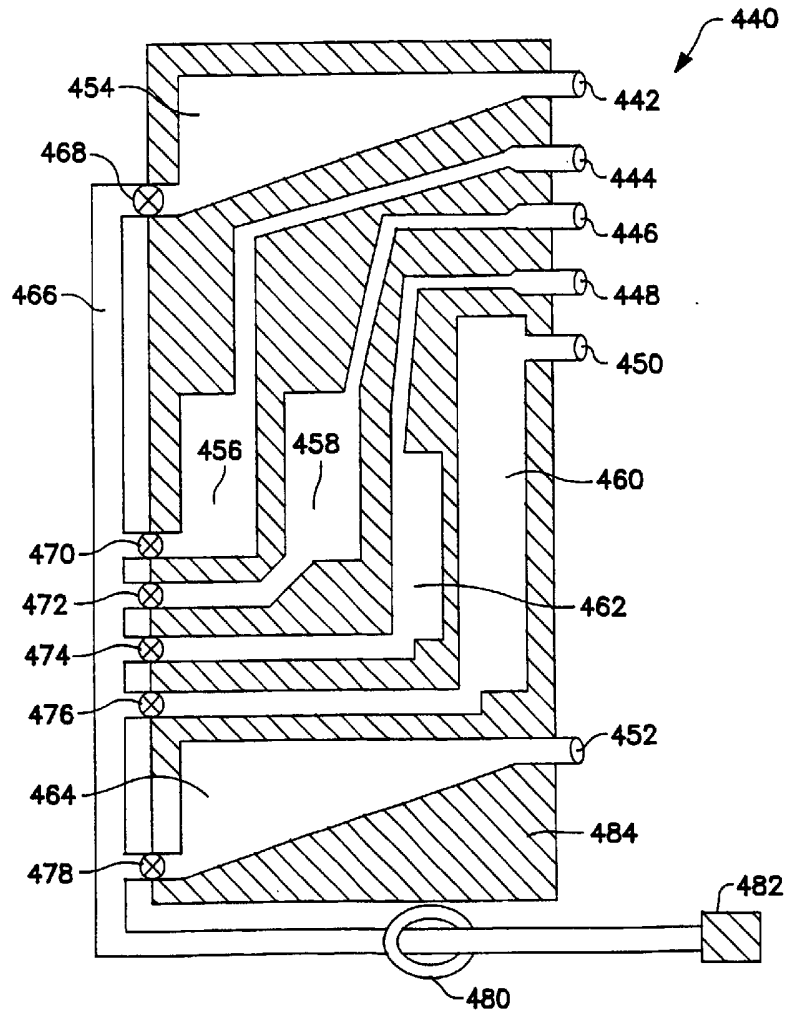

FIG. 12

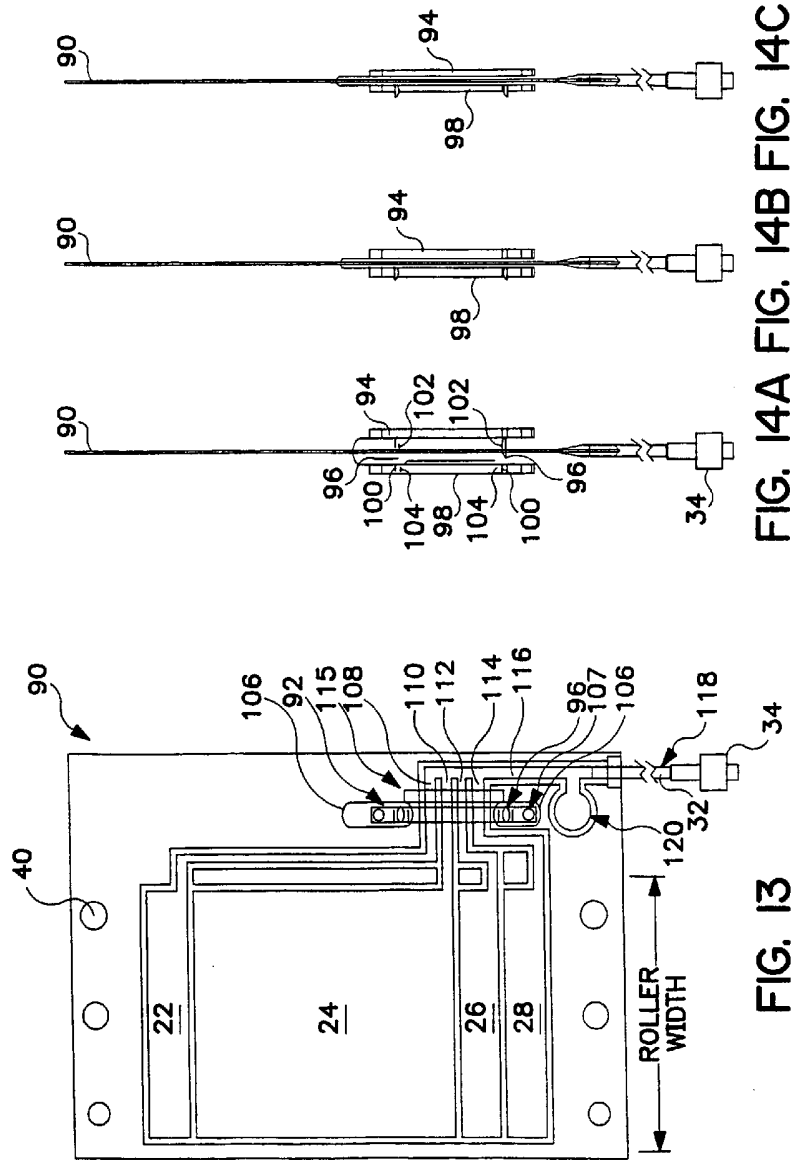
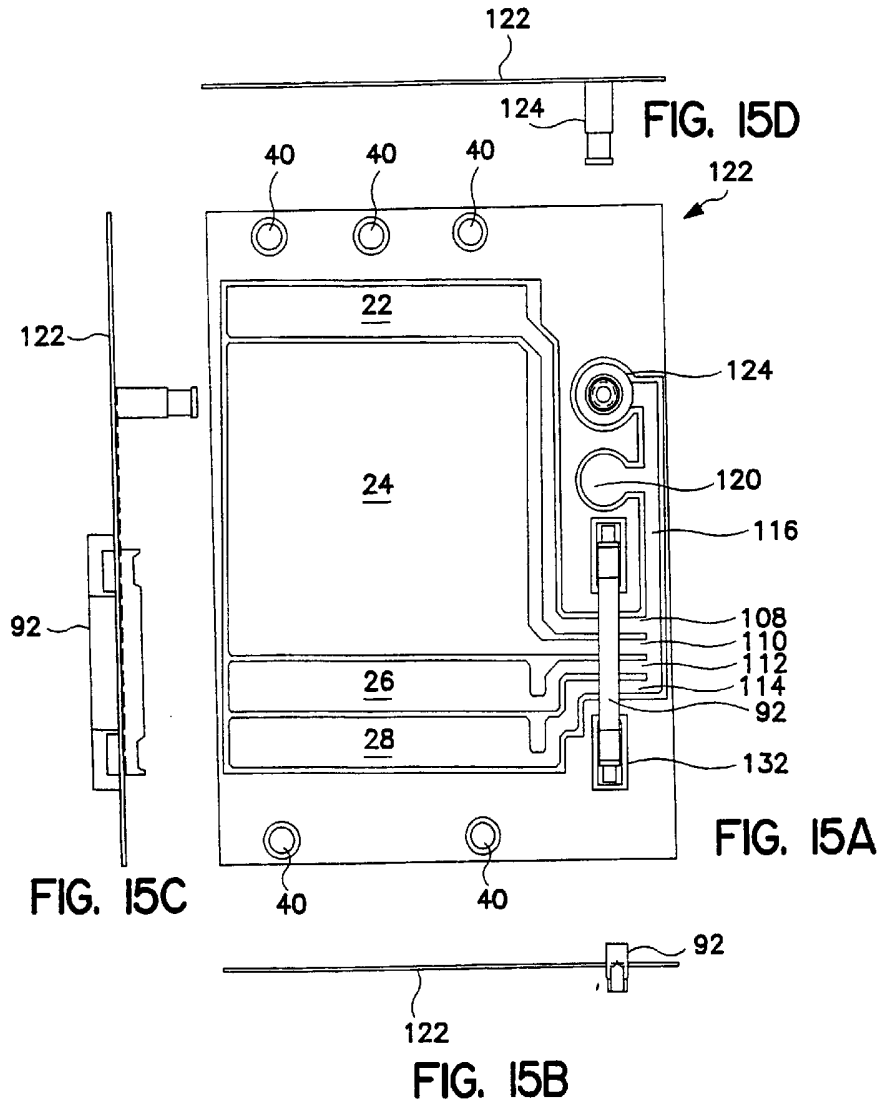

FIG. 14A FIG. 14B FIG. 14C

FIG. 13



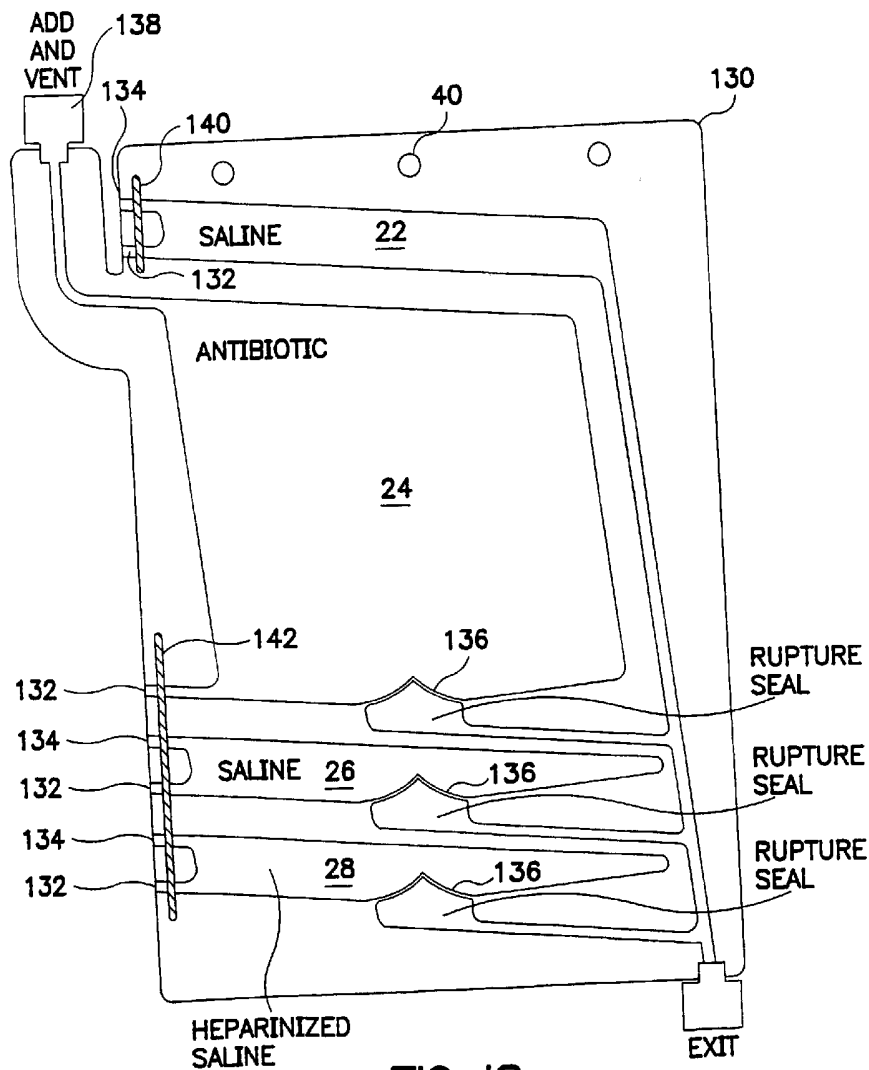

FIG. 16

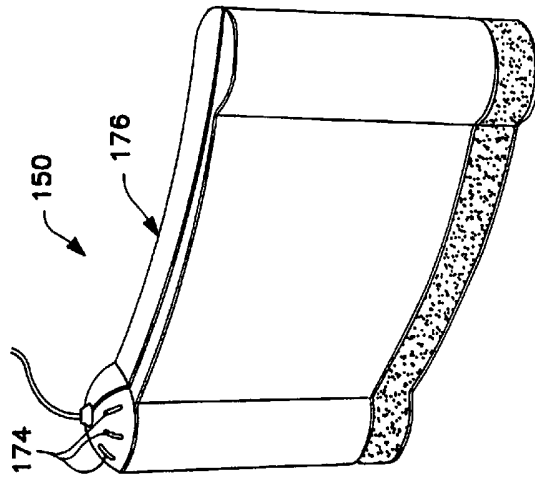

FIG. 17B

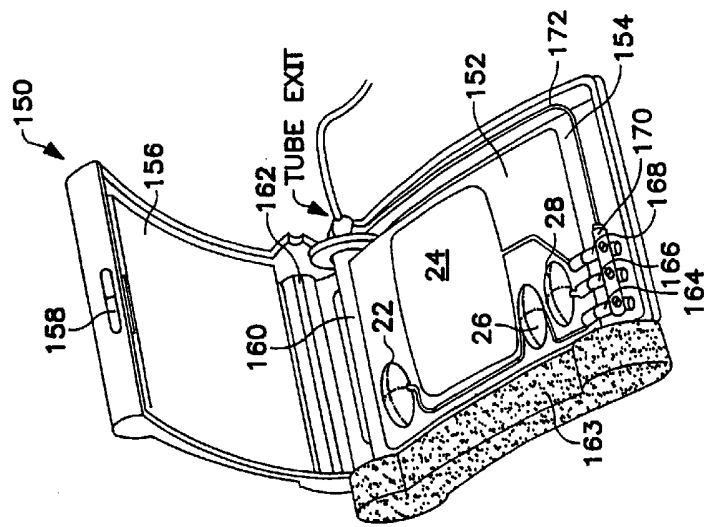

FIG. 17A

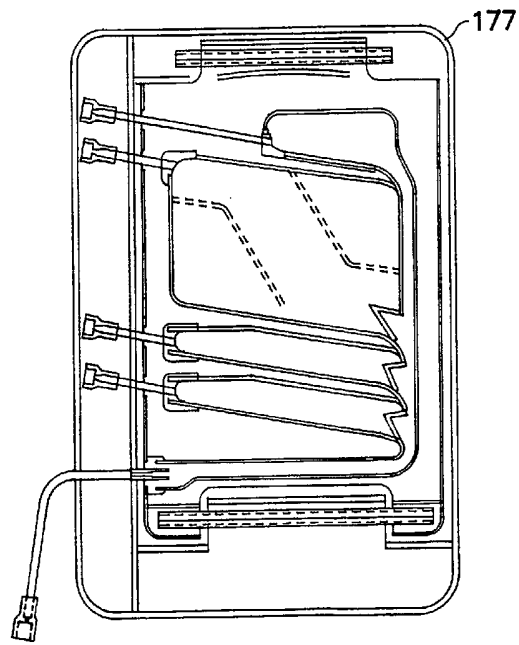

FIG. 18A

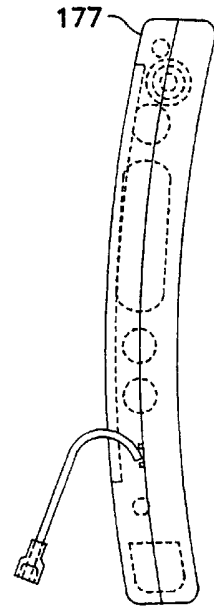

FIG. 18B

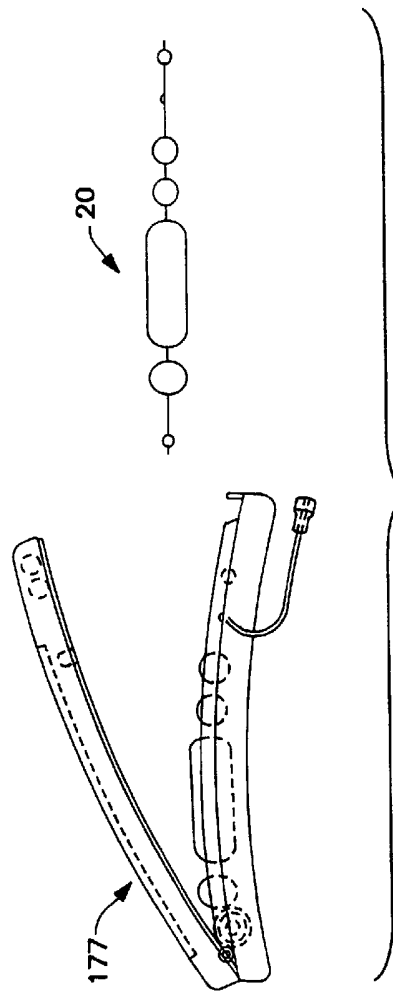

FIG. 18C

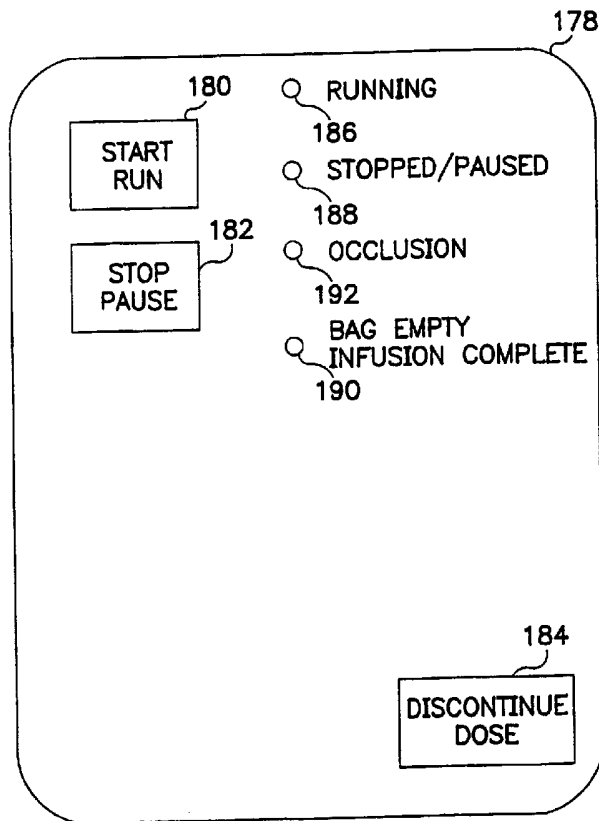

FIG. 19A

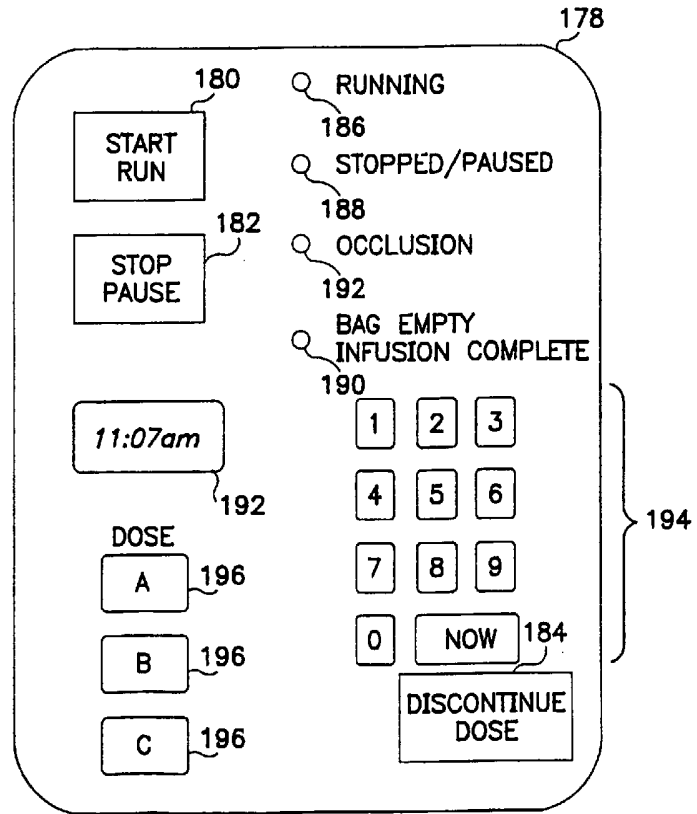
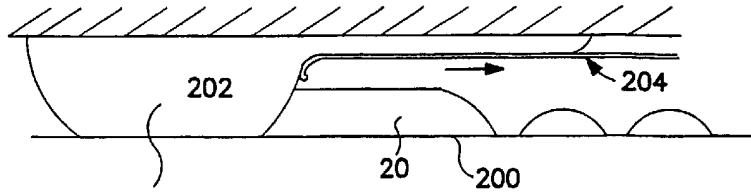
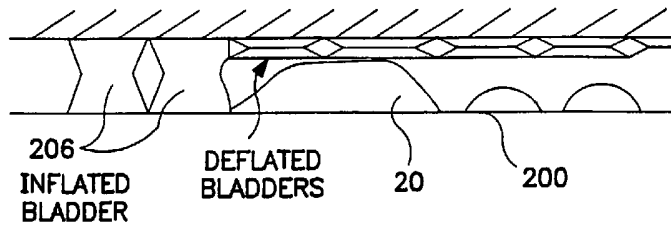

FIG. 19B



INFLATED BLADDER

FIG. 20



INFLATED
BLADDER

DEFLATED
BLADDERS

FIG. 21

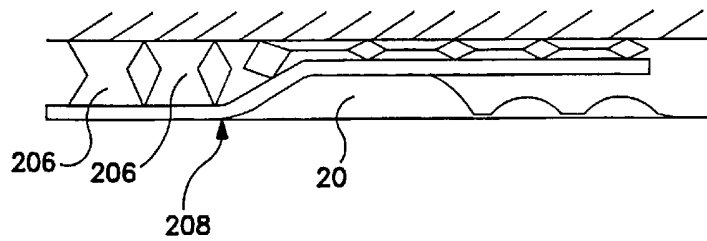

FIG. 22

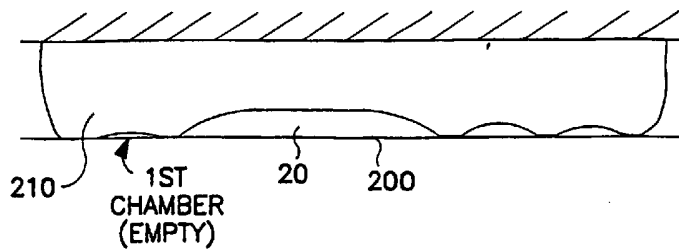

FIG. 23

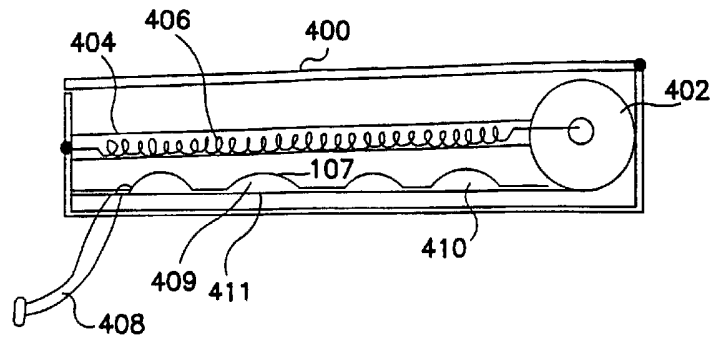

FIG. 24

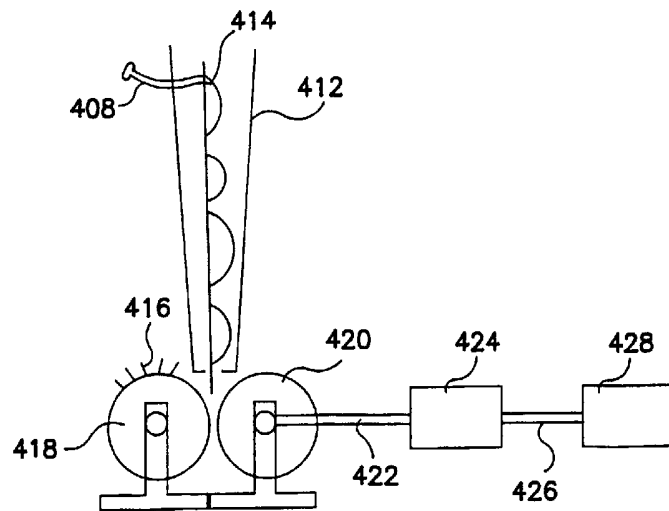

FIG. 25