

(21) Application No 9024710.7

(22) Date of filing 14.11.1990

(71) Applicant  
**Duoject Medical Systems Inc**  
  
(Incorporated in Canada)

Suite 308, 4920 de Maisonneuve St West, Montreal,  
Quebec, H3Z 1N1, Canada

(72) Inventor  
**David L Reynolds**

(74) Agent and/or Address for Service  
**J Y & G W Johnson**  
Furnival House, 14-18 High Holborn, London,  
WC1V 6DE, United Kingdom

(51) INT CL<sup>5</sup>  
**A61M 5/28**

(52) UK CL (Edition K)  
**A5R RCC**

(56) Documents cited  
**GB 2210268 A**

(58) Field of search  
UK CL (Edition K) **A5R RCC RCM**  
INT CL<sup>5</sup> **A61M**

(54) Syringe vial

(57) A syringe vial (2) has a strengthening bead (6) at its wider open end to which a finger grip (68) can be secured and which extends internally of the syringe wall (4). The piston (8) has a flexible extension (20) configured for releasable coupling with a plunger (46) for controlled dispensing of contents conventionally filled into the vial.

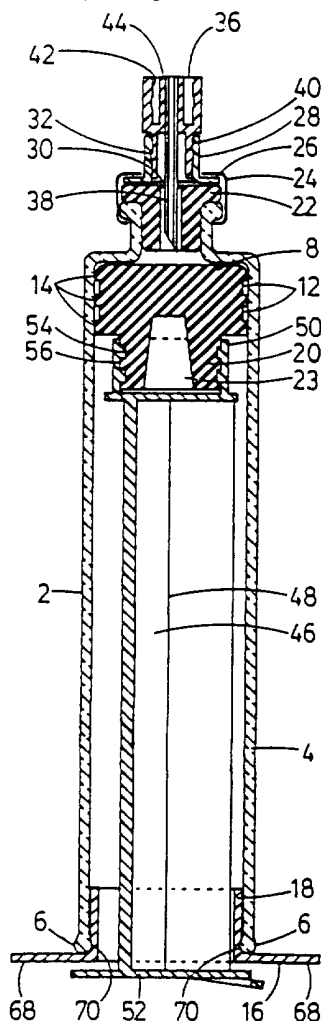

FIG.3

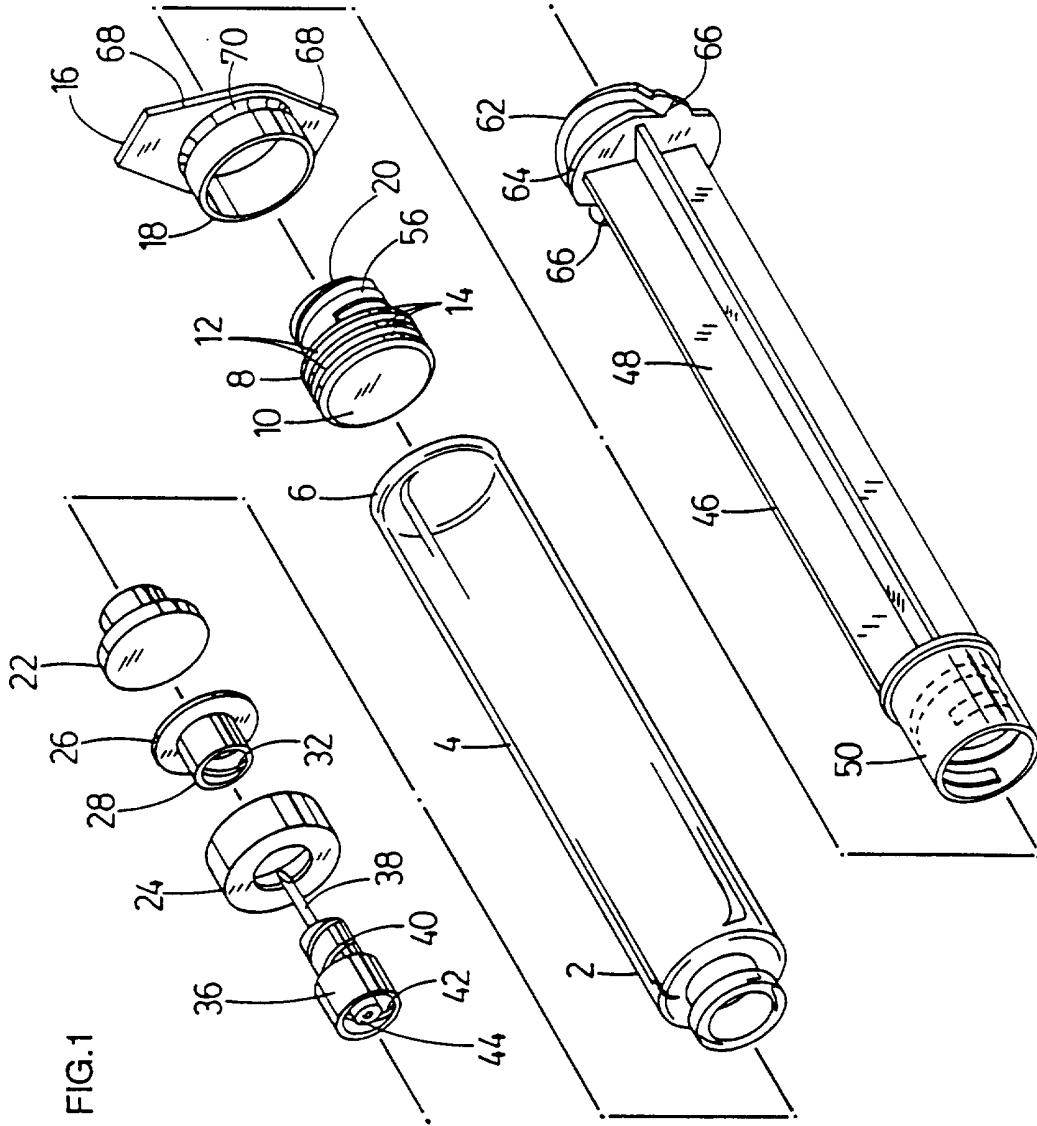

FIG. 1

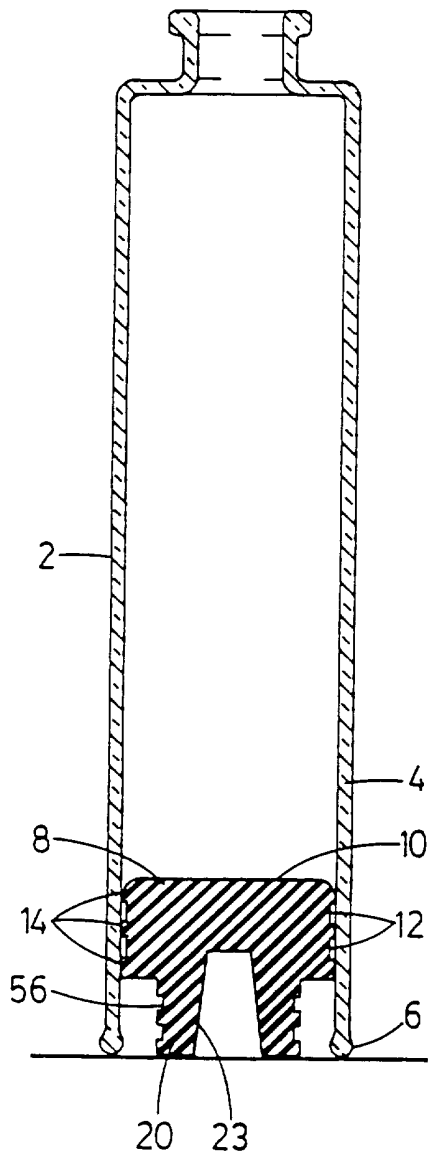

FIG. 2

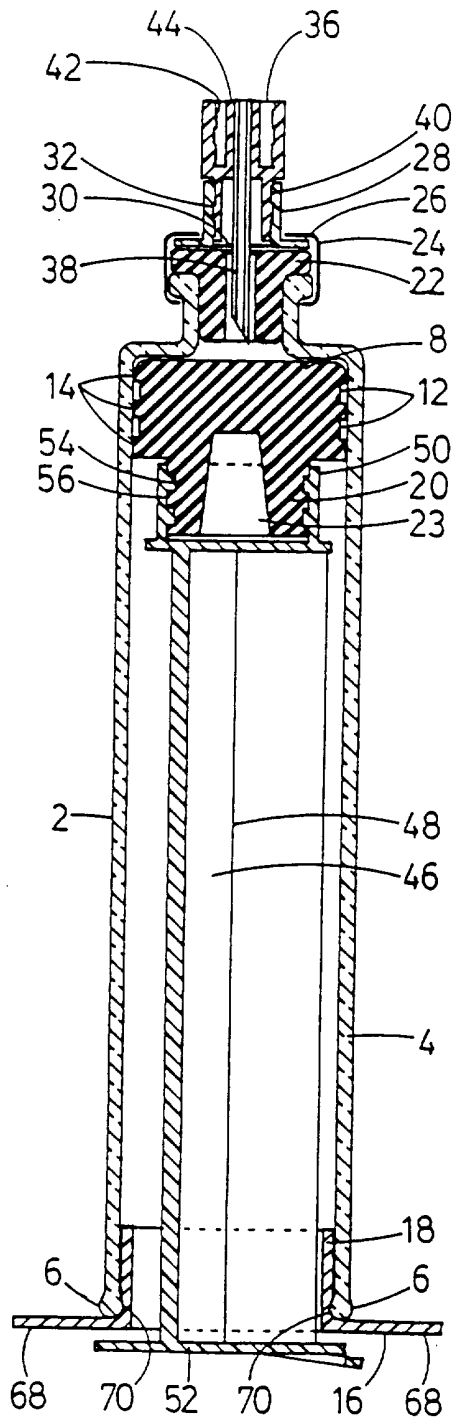

FIG. 3

3/3

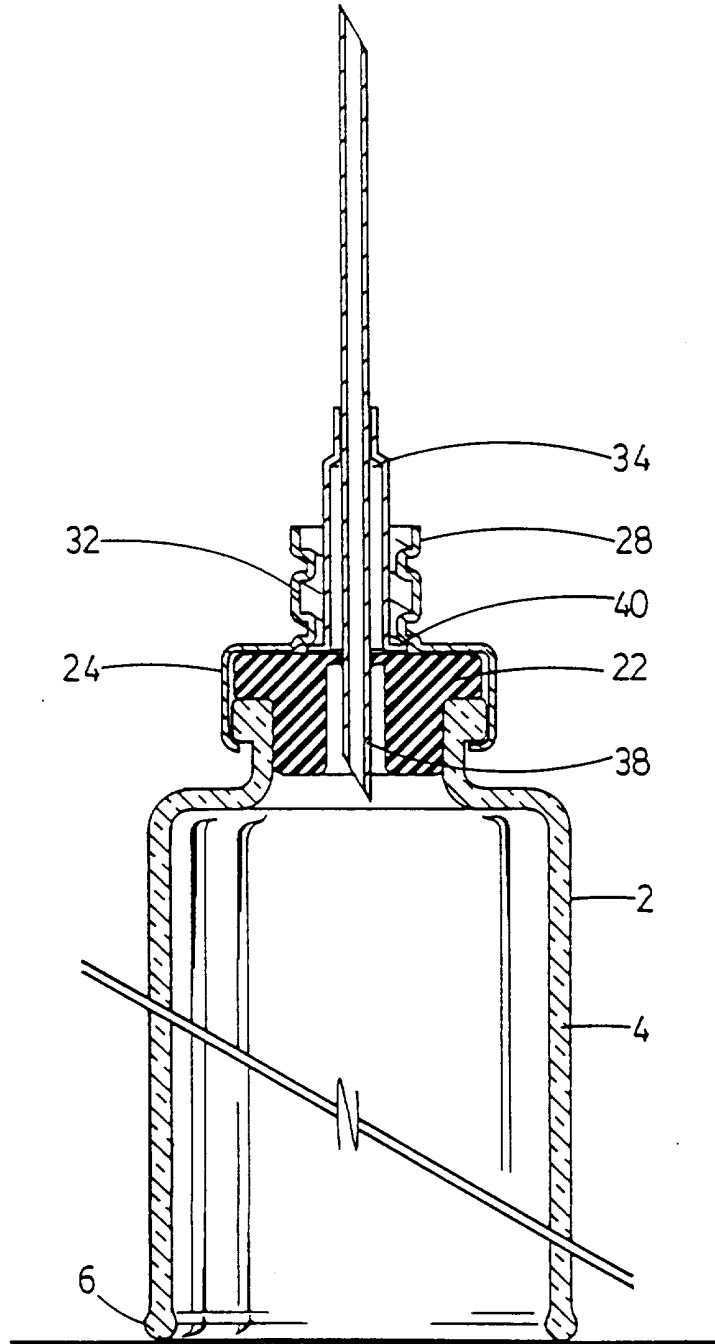

FIG. 4

SYRINGE

This invention relates to prefilled syringes for use in medical or veterinary treatment.

5 In the applicant's published European Patent Application 0298585, there is disclosed a syringe system based on the concept of a "bottomless vial" in which the conventional base of a glass vial is replaced by a rubber piston which forms a hermetic seal with the walls of the vial, and which has a downward extension within the vial which can be coupled to a syringe plunger. When a plunger is so coupled to the piston, and an adaptor is applied to a cap of the vial, the vial is converted into a syringe. 10 An extremely important advantage of a syringe based upon such a bottomless vial, as compared to conventional prefilled syringe systems, is that it can be filled and capped utilizing conventional vial filling equipment generally available and in use in the pharmaceutical industry, rather than requiring specialized capital intensive filling systems, and that the number of clean room operations required in production of the product is 15 greatly reduced as compared with known syringe assembly and filling systems. As described in more detail in the above application, the system is also extremely versatile in that the "bottomless vial" can form the basis of a wide range of 20 syringe delivery systems. 25

The very reason for the advantages of the above system, namely that the vials can be filled and capped utilizing conventional vial filling machinery, is also a limitation in certain applications, since the vials must remain stable whilst passing through the machinery, which in turn limits the permissible height of the vial relative to its diameter. This problem is aggravated by the necessity for providing a bead around the external periphery of the bottom of the vial, both in order to provide necessary strength to the glass and to provide means for anchoring a component of the syringe such as a combined plunger grip and plunger guide which is applied after filling of the vial, by pressing it over the bead. The projection of the bead, although kept to a minimum, interacts with the beads of adjacent vials and other obstructions in such a manner as to reduce the stability of the vial. Additionally, the application of the adaptor to the cap of the vial is an additional clean-room operation which is not required during the filling of conventional vials.

Although it is generally considered that the inner side walls of syringes should be smooth and unobstructed, it has now unexpectedly been found that considerable advantages can be obtained by forming the peripheral bead at the base of a "bottomless vial" at least partially on the internal periphery of the base of the vial. This makes it possible for the external peripheral bead to be reduced or eliminated, which improves the stability of the vial and enables its height to diameter ratio to be somewhat increased. It is also found that a versatile combined finger grip and plunger guide of much simplified construction yet improved performance can be utilized in conjunction with the modified bead.

It is also found that in many applications it is possible to dispense with the application of a separate adaptor to the cap of the vial by incorporating an adaptor into the cap structure in a manner which does not interfere with normal operation of the conventional vial capping machinery.

These and other features of the invention are set forth in the appended claims.

For a better understanding of the invention, reference may be had to the following description of a preferred embodiment thereof, with reference to the accompanying drawings in which:

Figure 1 is an exploded isometric view of the components of the syringe;

Figure 2 is a vertical section through a vial portion of the syringe, ready for filling;

Figure 3 is a longitudinal section through an assembled syringe, after discharge of its contents; and

Figure 4 is a fragmentary longitudinal section on an enlarged scale of a portion of the syringe shown in Figure 3, showing a modification of the arrangement shown in that Figure.

Referring to the drawings, a syringe comprises a syringe barrel in the form of a somewhat elongated glass vial 2, of which the bottom wall is absent apart from a slight inward projection of a strengthening bead 6 formed at the bottom of a side wall 4 of the vial and best seen in Figure 4. In the example shown the strengthening bead 6 also has a very slight outward projection, but this is far smaller than would be necessary if the bead were formed wholly externally of the side wall 4, and may be entirely eliminated. In any event, the outward extent of the projection should be insufficient to prevent vials from

standing very closely adjacent to one another without sufficient space to tip. Typically the projection will not exceed about one fifth of the total thickness of the bead. The projection of the bead on the inside should also be limited, both so that the head 10 of a moulded rubber piston 8 can be inserted into the vial past the projection (this is facilitated by the presence of peripheral grooves 12 in the head between sealing lands 14), and so that a sleeve 18 of a combined finger grip, piston stop and plunger guide 16 (henceforth referred to as the finger grip) can be pushed past the projection whilst remaining a snug fit within the side wall of the vial.

The piston 8 is also provided with an integrally moulded downward extension 20 which is formed with a central cavity 23 to increase its flexibility relative to the head 10 of the piston which is substantially solid. The piston is dimensioned so that when it is inserted in the vial 2, the lands 14 are compressed sufficiently to form a hermetic seal against the interior of wall 4 whilst permitting the piston to be moved longitudinally of the vial. Initially, the piston is located at the bottom of the vial (see Figure 2), with the bottom of extension 20 just within the vial so that it does not affect the ability of the vial to stand upright on its base formed by the bead 6. The location of the fairly massive solid rubber piston 8 at the base of the vial helps stabilize the empty vial 2, even when the height of the latter is somewhat greater relative to its diameter than is normally required for stability. The practical limit of the height to diameter ratio is set entirely by the requirement that the vials can be conveyed through a conventional vial filling and capping machine in a sufficiently stable manner to permit reliable operation of the machine. In the example shown, the vial has an outside diameter of approximately 3 cm and a height of 12.8 cm, which is believed to approach the practical



limit for stability, but this ratio will vary somewhat according to the relative wall thickness of the vial and the weight of the piston. Provided that the outward projection of the bead 6 is insufficient to affect stability, so that the vials can jostle without applying tipping force to each other, and assuming use of a piston generally as described, the maximum ratio attainable should be greater than 4, but will be less than 5.

The stopper 22 and cap 24 applied by the conventional vial filling and capping machinery may be of conventional construction, although the stopper 22 is preferably designed substantially to fill the neck of the vial so as to minimize dead space above the piston when the latter is pushed to the top of the vial (See Figure 3). This ensures that as much as possible of the contents of a syringe formed from the vial can be expelled by movement of the piston.

The cap 24 is preferably modified as shown in Figure 3 and Figure 5. In Figure 3, a conventional main cap cooperates with a moulded plastic adaptor assembly comprising an annular flange 26 within the cap, a cylindrical extension 28 extending through the cap and a thin diaphragm 30 closing a bottom end of the extension. An internal thread 32, similar to that provided on conventional syringe adaptors for receiving needles, such as those sold under the trade-mark LUER-LOK, is formed within the adaptor. A removable push on cap may be provided to close the open end of the adaptor during storage, being removed prior to use. In Figure 4, the cylindrical extension 28 is formed integrally with the aluminum cap, again with an internal thread 32. I have found that the extension 28 can be accommodated by conventional vial capping machinery, at any rate with no more than minor modification, without interfering with the

capping process, whilst the provision of such an extension enables the elimination of a separate adaptor cap, and the additional assembly step required to apply it.

In order to convert the vial into a syringe, either  
5 a double ended needle 34 of the blood collecting type may be applied directly to the extension 28 (See Figure 4) or an adaptor 36 (See Figures 1 and 3) may be provided for any  
10 needle or alternative delivery device equipped with a standard syringe coupling so as to provide the latter with the capability of penetrating the stopper 22, as well as  
15 the diaphragm 30 if present. The adaptor 36 has a needle 38 and external thread 40 at one end, the needle providing the penetration function and the thread 40 engaging the thread 32, while its other end provides an internally threaded socket 42 and coaxial spigot 44 for forming a fluid-tight coupling to the needle or the like.

Prior to fitting the double ended needle 34, or needle and adaptor 36, a plunger 46 is applied to the extension 20 of the piston. The plunger has a shaft 48, of  
20 cruciform cross-section in the example shown, an internally threaded sleeve 50 at its one end, and an end flange 52 at its other end. The sleeve 50 has internal multistart threads 54, complementary to external multistart threads 56 on the extension 20. The lands between the threads 54 on  
25 the sleeve 50 and the threads 56 on the extension 20 both stop short respectively of the outer end of the sleeve 50 and the inner end of the extension 20 so as to form abutments 58,60 which prevent the sleeve 50 from being screwed tightly against the underside of the head 10 of the  
30 piston. This means that any tilting forces applied to the plunger are applied to the relatively flexible extension 20 and not directly to the head 10, thus minimizing the risk of breaking the hermetic seal between the head 10 and the vial.

The plunger is formed of a hinge-forming synthetic plastic such as a pharmaceutical grade polypropylene, and a generally semicircular peripheral portion 62 of the flange and is separated from the remainder by a slot 64, remaining connected only by thin, hinge-forming connections 66. This portion 62 provides a finger loop which can be pulled rearwardly, as shown by broken lines in Figure 1, to facilitate handling of the plunger.

In order to provide the various functions of preventing total withdrawal of the piston, forming a guide for the plunger and restricting its tilting movements, and providing a finger grip for the user, the combined finger grip 16 is pressed into the bottom of the vial 2 after filling and capping of the latter. It comprises the sleeve 18 and a peripheral flange forming oppositely extending finger tags 68. It is also moulded from pharmaceutical grade plastic such as polypropylene. The sleeve 18 is a resilient press fit in the open end of the vial 4 so that it is slightly compressed by the internal projection of the bead 6 during insertion. Beneath the grips 68 the sleeve has shallow arcuate grooves 70 in which the bead 6 snaps as the sleeve is pressed home. Forces applied to the grips 68 tending to pull the sleeve 18 away from the vial in turn tend to deform the sleeve, in such a manner as to increase the grip of the grooves 70 on the bead thus resisting withdrawal of the sleeve.

During manufacture, the piston 8 is placed in the vial 4, and the latter is filled and capped utilizing conventional vial filling and capping machinery (but preferably using a modified cap as shown in Figures 1 and 3 or Figure 5). The guide and finger grip 18 is then pressed into the base of the vial, which is shipped with the plunger 46 unattached. Prior to use, the plunger 46 is

screwed onto the piston, and a needle or the like is applied to the extension 28, utilizing an adaptor 36 if necessary so as to penetrate the stopper 22, at which point the syringe is ready for use.

CLAIMS:

1. A vial for forming a barrel and a piston of a syringe, comprising a cylindrical glass body having at one end an open neck and a peripheral external flange around an outer end of the neck, and a peripheral thickened bead at  
5 an open opposite end, the bead being formed so that the bead is at least partly inwardly of an interior wall of the glass body, and a piston having a cylindrical head within and concentric with the cylindrical glass body in slidable hermetically sealing relationship with the inner surface of  
10 the body, the piston being located to define a chamber of volume equal to the nominal capacity of the vial between the piston head and the neck of the vial, the piston having an integral axial flexible extension of lesser diameter than the head and extending towards but ending just short  
15 of said open opposite end of the body, the flexible extension being configured for releasable coupling with a socket at an end of a plunger, and the vial having at least sufficient stability, when standing on the peripheral bead, to pass reliably through conventional vial filling and  
20 capping machinery without tipping over, any external extent of the bead beyond the remainder of an external wall of the body being sufficiently slight to leave said external wall free of projections having an adverse effect on the stability of the vial.
  
- 25 2. A vial according to claim 1, wherein the external extent of the bead is no more than 20% of the thickness of the bead.
  
3. A vial according to claim 1 or 2, wherein the vial has a height which is about 4 times its diameter.
  
- 30 4. A vial according to any one of claims 1 - 3, further including a pharmaceutical product within the chamber, a

needle penetrable stopper inserted in the neck, and an annular cap crimped over said stopper and the flange of the neck to retain the stopper in hermetic engagement with the neck.

5 5. A vial according to claim 4, wherein the cap is provided with a concentric tubular outward extension for receiving one of a double ended hollow needle and an adaptor for receiving a single ended hollow needle such that one end of the double ended needle, or a hollow needle  
10 provided on the adaptor, can penetrate the stopper.

6. A vial according to claim 5, wherein the outward extension is integral with the annular cap.

7. A vial according to claim 5, wherein the outward extension is formed separately and has a flange at its  
15 inner end which is captive between the cap and the stopper.

8. A vial according to any one of claims 4 - 7, further including a finger grip comprising a tubular member which is a press fit within the open end of the vial body, a flange at an outer end of the tubular member providing  
20 outwardly extending finger tabs, the tubular member being grooved in its external surface adjacent the flange in the vicinity of the finger tabs so as to receive the portion of the bead inward of the interior wall of the body.

9. A prefilled syringe, comprising a vial according to  
25 any one of claims 4-8, together with a plunger having a socket releasably engageable with the extension of the piston.

10. A prefilled syringe according to claim 9, wherein the extension of the piston and the socket of the plunger  
30 are provided with complementary external and internal

threads respectively, and with interengaging abutment means such as to prevent the plunger entering direct engagement with the head of the piston.

Patents Act 1977  
 Examiner's report to the Comptroller under  
 Section 17 (The Search Report)

Application number  
 9024710.7

Relevant Technical fields

(i) UK CI (Edition K ) A5R (RCC, RCM)

(ii) Int CI (Edition 5 ) A61M

Search Examiner

K E MILNE

Databases (see over)

(i) UK Patent Office

(ii)

Date of Search

30.1.91

Documents considered relevant following a search in respect of claims 1-10

Category (see over)	Identity of document and relevant passages	Relevant to claim(s)
A	GB 2210268 A (DUOJECT) (and EP 0298585 A1)	

SF2(p)



Category	Identity of document and relevant passages	Relevant to claim(s)

### Categories of documents

**X:** Document indicating lack of novelty or of inventive step.

**Y:** Document indicating lack of inventive step if combined with one or more other documents of the same category.

**A:** Document indicating technological background and/or state of the art.

**P:** Document published on or after the declared priority date but before the filing date of the present application.

**E:** Patent document published on or after, but with priority date earlier than, the filing date of the present application.

**&:** Member of the same patent family, corresponding document.

**Databases:** The UK Patent Office database comprises classified collections of GB, EP, WO and US patent specifications as outlined periodically in the Official Journal (Patents). The on-line databases considered for search are also listed periodically in the Official Journal (Patents).