

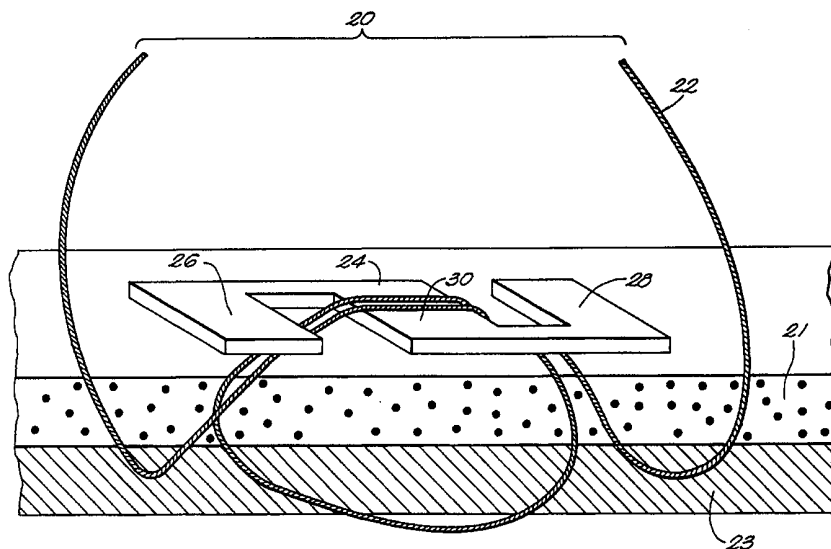

INTERNATIONAL APPLICATION PUBLISHED UNDER THE PATENT COOPERATION TREATY (PCT)

<p>(51) International Patent Classification⁶ : A61B 17/04</p>	<p>A1</p>	<p>(11) International Publication Number: WO 99/52450</p> <p>(43) International Publication Date: 21 October 1999 (21.10.99)</p>
<p>(21) International Application Number: PCT/US99/08128</p> <p>(22) International Filing Date: 13 April 1999 (13.04.99)</p> <p>(30) Priority Data: 09/061,472 16 April 1998 (16.04.98) US</p> <p>(71) Applicant: AXYA MEDICAL, INC. [US/US]; Suite 444C, 100 Cummings Center, Beverly, MA 01915 (US).</p> <p>(72) Inventor: EGAN, Thomas, D.; 12 South Street, Marblehead, MA 01945 (US).</p> <p>(74) Agents: LAPPIN, Mark, G. et al.; Lappin & Kusmer LLP, Two Hundred State Street, Boston, MA 02109 (US).</p>		<p>(81) Designated States: AU, CA, JP, European patent (AT, BE, CH, CY, DE, DK, ES, FI, FR, GB, GR, IE, IT, LU, MC, NL, PT, SE).</p> <p>Published <i>With international search report.</i></p>

(54) Title: A SUTURE TENSIONING AND FIXATION DEVICE



(57) Abstract

A suture tensioning fixation device (20) comprises a suture thread (22), and a suture retaining element (24). The retaining element (24) has a first suture thread engaging portion (26), a second suture thread engaging portion (28) opposite the first suture thread engaging portion (26), and a third centrally located suture thread engaging portion (30). The retaining element (24) is adapted such that segments of the suture thread (22) can be interwoven between the suture thread engaging portions of the retaining element (24). Localized melting of the retaining element (24) where it contacts the suture thread segments establishes a weld, and bonds the suture thread (22) to the retaining element (24) in a non-knotting joint.

FOR THE PURPOSES OF INFORMATION ONLY

Codes used to identify States party to the PCT on the front pages of pamphlets publishing international applications under the PCT.

AL	Albania	ES	Spain	LS	Lesotho	SI	Slovenia
AM	Armenia	FI	Finland	LT	Lithuania	SK	Slovakia
AT	Austria	FR	France	LU	Luxembourg	SN	Senegal
AU	Australia	GA	Gabon	LV	Latvia	SZ	Swaziland
AZ	Azerbaijan	GB	United Kingdom	MC	Monaco	TD	Chad
BA	Bosnia and Herzegovina	GE	Georgia	MD	Republic of Moldova	TG	Togo
BB	Barbados	GH	Ghana	MG	Madagascar	TJ	Tajikistan
BE	Belgium	GN	Guinea	MK	The former Yugoslav Republic of Macedonia	TM	Turkmenistan
BF	Burkina Faso	GR	Greece	ML	Mali	TR	Turkey
BG	Bulgaria	HU	Hungary	MN	Mongolia	TT	Trinidad and Tobago
BJ	Benin	IE	Ireland	MR	Mauritania	UA	Ukraine
BR	Brazil	IL	Israel	MW	Malawi	UG	Uganda
BY	Belarus	IS	Iceland	MX	Mexico	US	United States of America
CA	Canada	IT	Italy	NE	Niger	UZ	Uzbekistan
CF	Central African Republic	JP	Japan	NL	Netherlands	VN	Viet Nam
CG	Congo	KE	Kenya	NO	Norway	YU	Yugoslavia
CH	Switzerland	KG	Kyrgyzstan	NZ	New Zealand	ZW	Zimbabwe
CI	Côte d'Ivoire	KP	Democratic People's Republic of Korea	PL	Poland		
CM	Cameroon	KR	Republic of Korea	PT	Portugal		
CN	China	KZ	Kazakstan	RO	Romania		
CU	Cuba	LC	Saint Lucia	RU	Russian Federation		
CZ	Czech Republic	LI	Liechtenstein	SD	Sudan		
DE	Germany	LK	Sri Lanka	SE	Sweden		
DK	Denmark	LR	Liberia	SG	Singapore		
EE	Estonia						

A SUTURE TENSIONING AND FIXATION DEVICE

Field of the Invention

The invention relates to surgical devices used for suture fastenings.

Background of the Invention

5 In the surgical repair of soft tissue, such as, for example, the surgical reattachment of ligaments to bone or the attachment of tendon to muscle, it is known to use multi-part devices to surgically fasten the soft tissues to be repaired. By way of example, U.S. Patent No. 5,593,425 discloses surgical devices assembled using heat bondable material. The '425 patent teaches that a portion of a suture thread is
10 inserted into an opening in a retainer formed of a plastic material. At least one portion of the retainer is heated to its melting point. The plastic material of the retainer flows around the suture thread and creates a bond with the suture thread as the plastic material cools below its melting point.

Often these surgical procedures are performed endoscopically. Endoscopic
15 procedures typically require the surgeon to perform the procedure through a very small opening which requires particular dexterity. One disadvantage of the device disclosed by the '425 patent is that the surgeon must maintain tension on the retainer while simultaneously heat bonding the retainer to the suture, a sometimes difficult procedure.

20 It would therefore be an advantage to provide a device that would hold the suture thread when the suture thread is pulled taut through the device. Thus, the surgeon would not have to simultaneously maintain tension on the retainer while heat bonding the retainer to the suture thread because the retainer holds the suture thread and maintains tension when the suture thread is pulled taut. This device, therefore,
25 better enables the surgeon to perform surgical procedures through the small openings typically encountered in endoscopic procedures.

Summary of the Invention

According to one aspect of the present invention, there is provided a suture tensioning and fixation device used for suture fastening of tissues. The device
5 comprises a suture thread and a suture retaining element. The retaining element has a first suture thread engaging portion on the first end, a second suture thread engaging portion opposite the first suture thread engaging portion, and a third substantially centrally located suture thread engaging portion.

The retaining element is adapted such that segments of the suture thread can
10 be interwoven between the suture thread engaging portions of the retaining element. The suture thread engaging portions of the retaining element are adapted to frictionally hold the interwoven suture thread segments.

The retaining element and the suture thread can be bonded together upon the application of energy, such as thermal or ultrasonic energy, thereto. In a preferred
15 embodiment, the retaining element and suture are made of plastic materials. The retainer material preferably has a melting point which is lower than the melting point of the suture thread. Heat applied to the retainer melts the retaining element. The melted plastic flows around the suture, binding or fixing the suture in place upon cooling. In a preferred embodiment, the suture thread has a braided construction to
20 provide interstices for the melted retainer material to flow into.

While any method of heating known to those skilled in the art is suitable, the retaining element is preferably melted via application of ultrasonic energy.

In another preferred embodiment, the substantially centrally located suture thread engaging portion of the retaining element is channeled or grooved or
25 otherwise adapted to retain the suture thread.

Brief Description of the Drawings

The invention is further described by the following description and figures, in
30 which:

FIG. 1 is a perspective view of the suture tensioning and fixation device

according to one embodiment of the the present invention, in which the suture retaining element has a serpentine shape;

FIG. 2 is a perspective view of another embodiment of the retaining device of the present invention, in the shape of a figure 8;

5 FIG. 3 is a cross-sectional view of one preferred embodiment of the device in which the centrally located suture engaging portion has a channel to receive and retain one or more segments of the suture thread;

FIG. 4 is a cross-sectional view of one preferred embodiment of the device in which the suture engaging portion has a plurality of projecting tabs to receive and retain one or more segments of the suture thread; and

10 FIG. 5 is a cross-sectional view of FIG. 4 after the retaining element has been bonded to the suture.

Like elements in the respective FIGURES have the same reference numbers.

15 **Detailed Description of the Preferred Embodiments**

The suture tensioning and fixation device according to the present invention is illustrated in FIG. 1. The device 20 comprises a suture thread 22 and a retaining element 24. The retaining element 24 is comprised of a first suture thread engaging portion 26, a second suture thread engaging portion 28 and a third suture thread engaging portion 30, located substantially centrally between the first suture thread engaging portion 26 and the second suture thread engaging portion 28. This embodiment has a serpentine shape which permits convenient passage of suture thread segments around the suture thread engaging portions.

25 A perspective view of the retaining element 24 according to one preferred embodiment of the present invention is shown in FIG. 2. In this embodiment the retaining element 24 is in the shape of a figure 8.

The retaining element may have any shape which is suitable for frictionally binding the suture thread. The serpentine shape is desirable because it allows the surgeon to more easily feed the suture thread into the retaining element. In another embodiment, the preferred shape of the retaining element is a figure 8. This

embodiment is desirable because the suture thread cannot slip laterally from the retaining element.

FIG. 3 shows a cross-sectional view of the third centrally located suture thread engaging portion 30 of the retaining element 24. The third suture engaging portion 30 has a void region or channel 34 adapted to receive the suture thread 22.

FIG. 4 illustrates a cross-sectional view of another preferred embodiment of the third suture thread engaging portion 30 of the suture tensioning and fixation device 24. The third suture engaging portion 30 has a plurality of projecting tabs 32 at the sides of the channel 34. The tabs receive and retain the suture thread 22 within the channel 34 and are easily contacted by an ultrasonic welding horn or a heat source to melt them around the suture.

According to the present invention, the suture thread 22 is threaded, for example, through two segments of tissue 21 and 23 to be surgically fixed, as shown in FIG. 1. Segments of the suture thread 22 are then interwoven between the first suture thread engaging portion 26, the second suture thread engaging portion 28, and the third suture thread engaging portion of the retaining element 24, as shown in FIG. 1. The ends of the suture thread 22 are preferably tucked under the first and second portions 26 and 28 to hold them in place. The suture thread is pulled taut and is frictionally held in place by the first, second, and third suture thread engaging portions 26, 28, 30, in preparation for bonding of the retaining element to the suture thread.

The retaining element and the suture thread are preferably heat bondable. In this embodiment, the retaining element and the suture may be made of a plastic material. The retaining element preferably has a melting point which is lower than the melting point of the suture thread. The suture may be a braided structure to provide interstices for receiving the melted material of the retaining element. Energy is then applied in the form of ultrasonic or thermal energy, which melts the retaining element. The melted plastic flows around the suture, binding or fixing the suture in place upon cooling. No knot is required to fix the suture in place. After the suture has been heat bonded, any excess segments of suture thread may be cut off.

Any method of heating known to those skilled in the art is suitable to heat and

melt the plastic material of the retaining element. These include a hot air gun, a small welding or soldering gun, and ultrasonic wands. Preferably, however, the retaining element is melted by application of ultrasonic energy through an ultrasonic weld horn 38 and anvil 40, shown in FIG 5.

5 FIG. 5 illustrates the retaining element 24 of FIG. 4 in which projecting tabs 32 are extending from the third suture engaging portion 30 are fused to the suture thread after application of ultrasonic energy to them. The melted material 36 flows around the suture thread 22 and into the interstices between the suture threads to form a permanent bond when cooled.

10 The invention may be embodied in other specific forms without departing from the spirit or essential characteristics thereof. The present embodiments are therefore to be considered in all respects as illustrative and not restrictive, the scope of the invention being indicated by the appended claims rather than by the foregoing description. All changes that come within the meaning and range of the equivalency
15 of the claims are therefore intended to be embraced therein.

I claim:

1

2

1. A suture tensioning and fixation device, comprising:

3

a. a suture thread; and

4

b. a suture retaining element having a first suture thread engaging

5

portion on one end of the retaining element, a second suture thread engaging portion

6

opposite the first suture thread engaging portion, and a third, substantially centrally

7

located, suture thread engaging portion;

8

wherein segments of the suture thread can be interwoven between the suture

9

thread engaging portions and wherein the suture thread engaging portions are adapted

10

to frictionally hold the interwoven suture thread segments.

1

2. The device according to claim 1, wherein the retaining element is heat

2

bondable to the suture thread.

1

3. The device according to claim 2, wherein the retaining element is a plastic

2

material having a melting point lower than the melting point of the suture thread.

1

4. The device according to claim 1, wherein the centrally located suture

2

engaging portion of the retaining element includes one or more channels for the

3

suture thread.

1

5. The device according to claim 4, wherein the centrally located suture

2

engaging portion of the channel includes one or more projecting tabs.

1

6. The device according to claim 1, wherein the retaining element has a

2

serpentine shape.

1

7. The device according to claim 1, wherein the retaining element has a figure

2

eight shape.

1 8. The device according to claim 1, wherein the suture thread is a braided suture
2 thread.

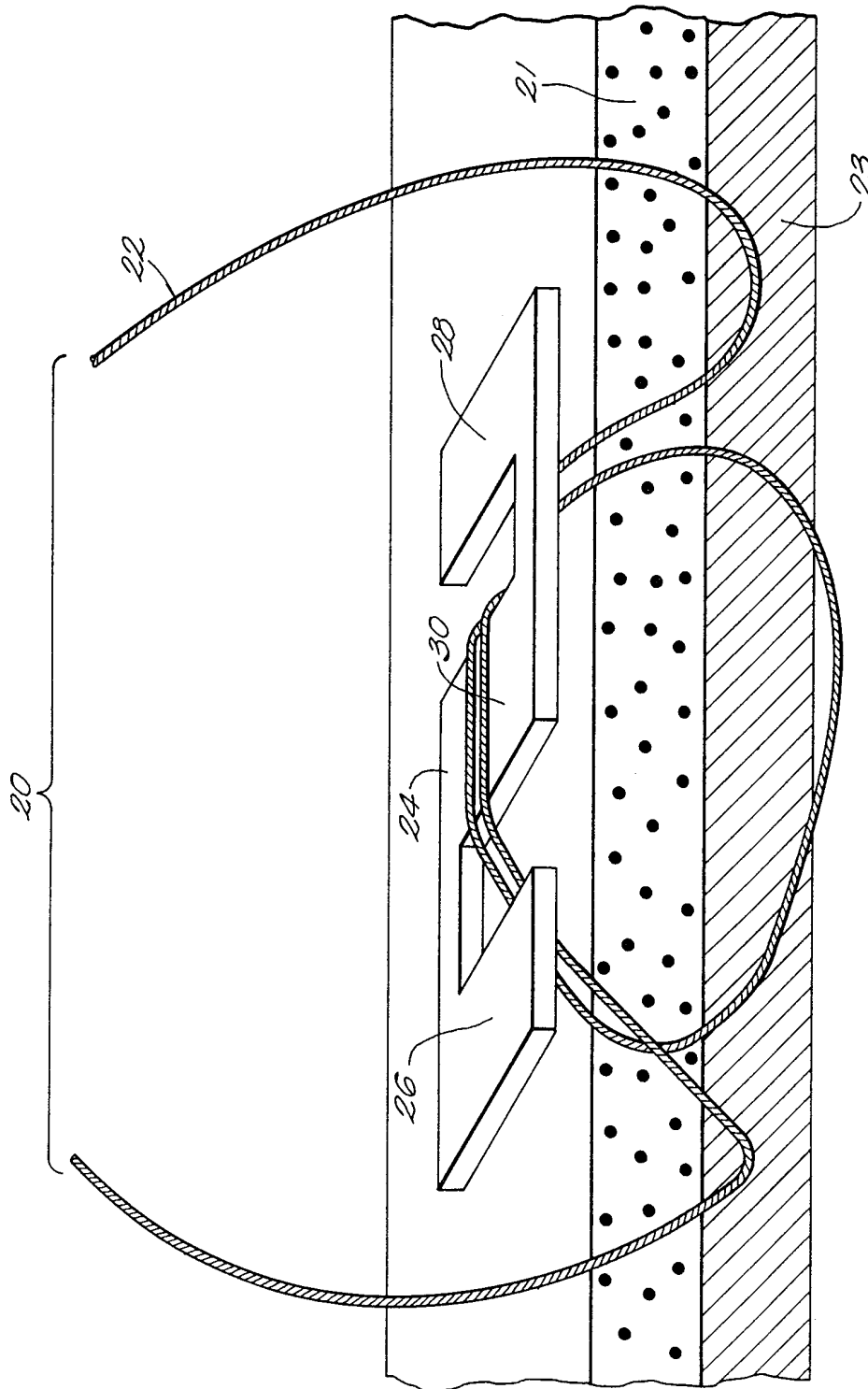

FIG. 1

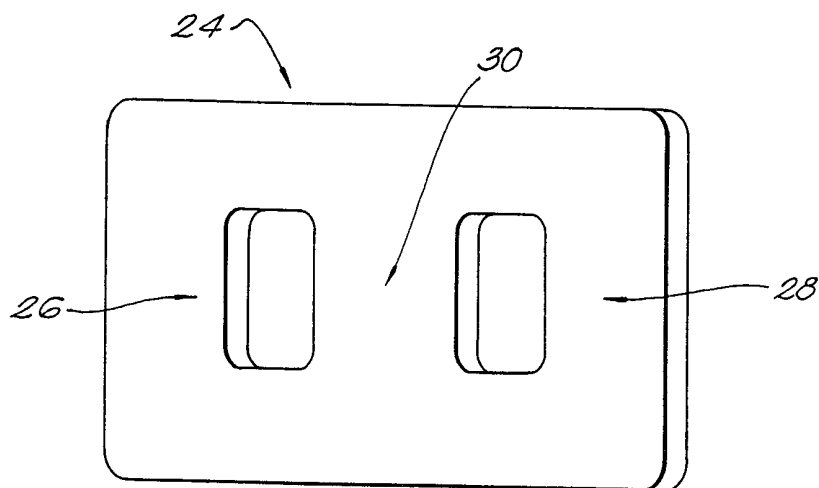

FIG. 2

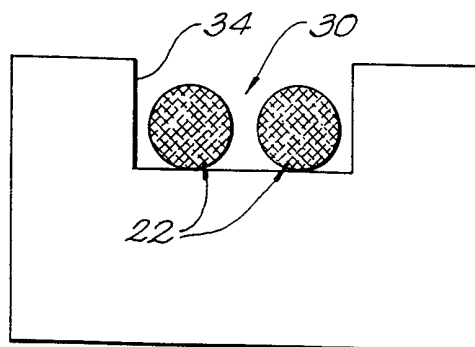

FIG. 3

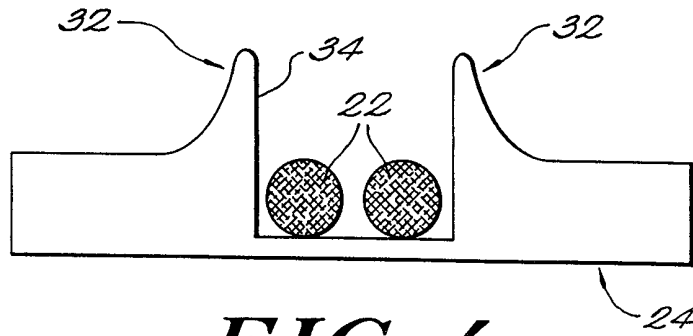

FIG. 4

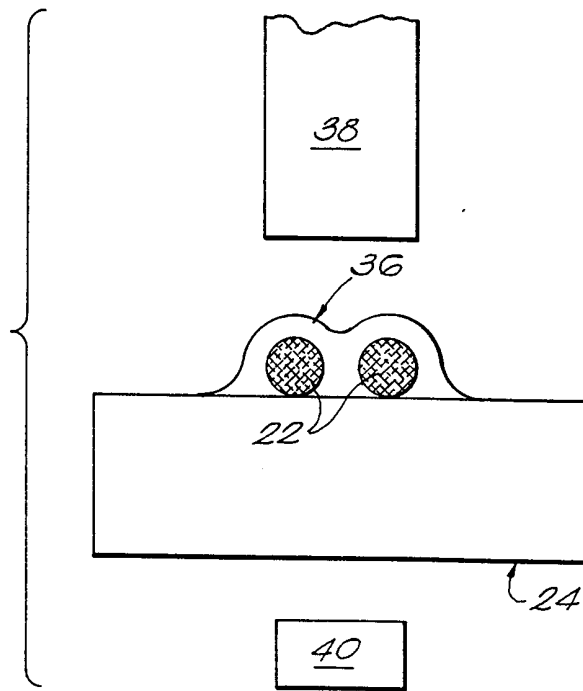
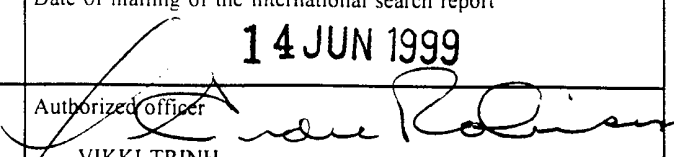

FIG. 5

INTERNATIONAL SEARCH REPORT

International application No.
PCT/US99/08128

A. CLASSIFICATION OF SUBJECT MATTER IPC(6) :A61B 17/04 US CL :606/232 According to International Patent Classification (IPC) or to both national classification and IPC		
B. FIELDS SEARCHED Minimum documentation searched (classification system followed by classification symbols) U.S. : 606/73, 220, 228, 232. Documentation searched other than minimum documentation to the extent that such documents are included in the fields searched Electronic data base consulted during the international search (name of data base and, where practicable, search terms used)		
C. DOCUMENTS CONSIDERED TO BE RELEVANT		
Category*	Citation of document, with indication, where appropriate, of the relevant passages	Relevant to claim No.
X	US 1,669,537 A (SCHAFFER) 15 May 1928, entire document.	1, 4-8
X	5,593,425 A (BONUTTI et al.) 14 January 1997, entire document.	1-3, 8
<input type="checkbox"/> Further documents are listed in the continuation of Box C. <input type="checkbox"/> See patent family annex.		
* Special categories of cited documents:	"T"	later document published after the international filing date or priority date and not in conflict with the application but cited to understand the principle or theory underlying the invention
"A" document defining the general state of the art which is not considered to be of particular relevance	"X"	document of particular relevance; the claimed invention cannot be considered novel or cannot be considered to involve an inventive step when the document is taken alone
"E" earlier document published on or after the international filing date	"Y"	document of particular relevance; the claimed invention cannot be considered to involve an inventive step when the document is combined with one or more other such documents, such combination being obvious to a person skilled in the art
"L" document which may throw doubts on priority claim(s) or which is cited to establish the publication date of another citation or other special reason (as specified)	"&"	document member of the same patent family
"O" document referring to an oral disclosure, use, exhibition or other means		
"P" document published prior to the international filing date but later than the priority date claimed		
Date of the actual completion of the international search 02 JUNE 1999	Date of mailing of the international search report 14 JUN 1999	
Name and mailing address of the ISA/US Commissioner of Patents and Trademarks Box PCT Washington, D.C. 20231 Facsimile No. (703) 305-3230	Authorized officer  VIKKI TRINH Telephone No. (703) 308-8238	