

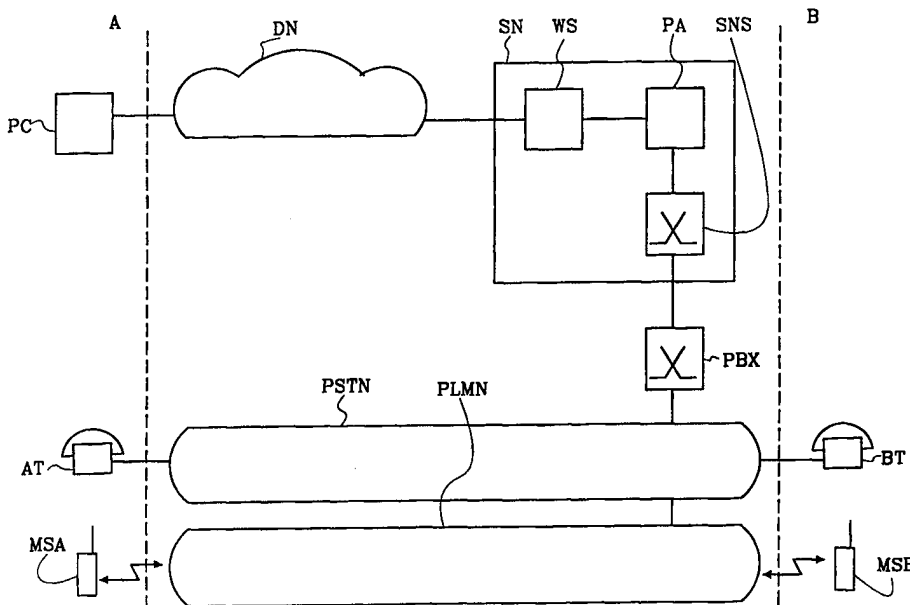

INTERNATIONAL APPLICATION PUBLISHED UNDER THE PATENT COOPERATION TREATY (PCT)

<p>(51) International Patent Classification ⁶ : H04M 11/00, 1/26, 3/42, H04L 29/06</p>	<p>A1</p>	<p>(11) International Publication Number: WO 98/19445 (43) International Publication Date: 7 May 1998 (07.05.98)</p>
<p>(21) International Application Number: PCT/SE97/01719 (22) International Filing Date: 14 October 1997 (14.10.97) (30) Priority Data: 9603930-0 28 October 1996 (28.10.96) SE (71) Applicant: TELEFONAKTIEBOLAGET LM ERICSSON (publ) [SE/SE]; S-126 25 Stockholm (SE). (72) Inventors: DANNE, Anders, Olof; Kastrupgatan 12, S-164 41 Kista (SE). PERGQVIST, Per; Lindhagensgatan 69, S-112 43 Stockholm (SE). BÅGE, Göran; Byvägen 10, S-133 34 Saltsjöbaden (SE). (74) Agents: WIDEBERG, Olle et al.; Telefonaktiebolaget LM Ericsson, Patent Dept., S-126 25 Stockholm (SE).</p>	<p>(81) Designated States: AL, AM, AT, AU, AZ, BA, BB, BG, BR, BY, CA, CH, CN, CU, CZ, DE, DK, EE, ES, FI, GB, GE, GH, HU, ID, IL, IS, JP, KE, KG, KP, KR, KZ, LC, LK, LR, LS, LT, LU, LV, MD, MG, MK, MN, MW, MX, NO, NZ, PL, PT, RO, RU, SD, SE, SG, SI, SK, SL, TJ, TM, TR, TT, UA, UG, UZ, VN, YU, ZW, ARIPO patent (GH, KE, LS, MW, SD, SZ, UG, ZW), Eurasian patent (AM, AZ, BY, KG, KZ, MD, RU, TJ, TM), European patent (AT, BE, CH, DE, DK, ES, FI, FR, GB, GR, IE, IT, LU, MC, NL, PT, SE), OAPI patent (BF, BJ, CF, CG, CI, CM, GA, GN, ML, MR, NE, SN, TD, TG).</p> <p>Published <i>With international search report.</i></p>	

(54) Title: DEVICE AND METHOD FOR COMMUNICATION BETWEEN A DATA NETWORK AND A TELECOMMUNICATIONS NETWORK



(57) Abstract

The present invention relates to a service node between Internet networks and a telecommunications network, said node being used to order telephony services by means of HTML pages from a computer having a WWW browser. The invention also relates to a method for calling a B subscriber, in which the call is ordered from the computer but the connection is set up between the telephones of the A and B subscribers' telephones. The service node communicates with computers connected to computer networks using the HTTP protocol. The node stores data related to a subscriber; said data can be used when the user requests a telephony service. The node is centrally located, which enables the use of its services even if the user moves to another location and terminal.

FOR THE PURPOSES OF INFORMATION ONLY

Codes used to identify States party to the PCT on the front pages of pamphlets publishing international applications under the PCT.

AL	Albania	ES	Spain	LS	Lesotho	SI	Slovenia
AM	Armenia	FI	Finland	LT	Lithuania	SK	Slovakia
AT	Austria	FR	France	LU	Luxembourg	SN	Senegal
AU	Australia	GA	Gabon	LV	Latvia	SZ	Swaziland
AZ	Azerbaijan	GB	United Kingdom	MC	Monaco	TD	Chad
BA	Bosnia and Herzegovina	GE	Georgia	MD	Republic of Moldova	TG	Togo
BB	Barbados	GH	Ghana	MG	Madagascar	TJ	Tajikistan
BE	Belgium	GN	Guinea	MK	The former Yugoslav Republic of Macedonia	TM	Turkmenistan
BF	Burkina Faso	GR	Greece			TR	Turkey
BG	Bulgaria	HU	Hungary	ML	Mali	TT	Trinidad and Tobago
BJ	Benin	IE	Ireland	MN	Mongolia	UA	Ukraine
BR	Brazil	IL	Israel	MR	Mauritania	UG	Uganda
BY	Belarus	IS	Iceland	MW	Malawi	US	United States of America
CA	Canada	IT	Italy	MX	Mexico	UZ	Uzbekistan
CF	Central African Republic	JP	Japan	NE	Niger	VN	Viet Nam
CG	Congo	KE	Kenya	NL	Netherlands	YU	Yugoslavia
CH	Switzerland	KG	Kyrgyzstan	NO	Norway	ZW	Zimbabwe
CI	Côte d'Ivoire	KP	Democratic People's Republic of Korea	NZ	New Zealand		
CM	Cameroon		Republic of Korea	PL	Poland		
CN	China	KR	Republic of Korea	PT	Portugal		
CU	Cuba	KZ	Kazakstan	RO	Romania		
CZ	Czech Republic	LC	Saint Lucia	RU	Russian Federation		
DE	Germany	LI	Liechtenstein	SD	Sudan		
DK	Denmark	LK	Sri Lanka	SE	Sweden		
EE	Estonia	LR	Liberia	SG	Singapore		

DEVICE AND METHOD FOR COMMUNICATION BETWEEN A DATA NETWORK
AND A TELECOMMUNICATIONS NETWORK

TECHNICAL FIELD

5 The present invention relates to a communication node between data networks and public telecommunications networks.

STATE OF THE ART

Such a communication node between data and telecommunications
10 networks is disclosed in, for example, WO 94/24803. This document describes such a node in a multimedia communication system. The object of the node is to enable communication between users using different types of terminals, such as common telephones, personal computers and workstations.

15

The published international patent application WO 87/078001 describes a node constituting an electronic mailbox. The object is for the mailbox to be able to receive and store electronic mail sent from different types of sources, such as telephones,
20 computers and fax machines. Messages may have been translated before they reach the mailbox. The electronic letters may subsequently be retrieved from different types of terminals.

Some different types of network architecture for establishing a link between data networks and telecommunications networks are described comprehensively in a report of a final thesis at Luleå Institute of Technology: "Functional Distribution between
5 Co-operating Networks", Bodin and Andreasson. The report briefly describes the design of a node between data networks and telecommunications networks, used to demonstrate the ordering of telephony services from a computer. A user is enabled to order telephony services presented on the computer
10 screen via pages in HTML format. The node consists of a computer with an off-the-shelf software platform.

SUMMARY OF THE INVENTION

The present invention attacks the problem of simplifying the
15 use of telecommunications services for a user by offering a solution with which such telecommunications services in public and private telecommunications networks may be made accessible through a computer. In particular this applies to the ordering from a computer of the set-up of a telecommunications
20 connection between an A subscriber and a B subscriber.

The telecommunications services of today are becoming more and more advanced. The new services are perceived as difficult to

use since conventional telephones are only provided with a primitive keypad allowing the user to enter commands or provide data. The telephone also has very limited possibilities for providing visual information.

5

With the new services, the need also arises to be able to adapt some of the services according to the user's desires. Thus the need for several alternative solutions for exchanging information with the user is further increased.

10

Another problem is avoiding having to equip the user's computer with special software to enable the ordering of telecommunications services from it. It should be sufficient for the computer to be provided with prior art software for communication, and said software should also be useful for other purposes than for ordering telephony services.

15

A further problem is that the user should have access to personal stored information concerning telecommunications services even if he/she moves geographically and changes computer and telephone equipment.

20

A purpose of the present invention is thus to enable a user to order telecommunications services, especially connection of calls, by means of a computer, in a way that is simple for the user and to provide subscriber related data that can be used
5 for this purpose, and to give access to these telecommunications services and this user related data even if the user moves geographically and to another telephone and/or computer.

10 A service node is provided, constituting a link between the data network and the telecommunications network. The service node has an interface to a telephone exchange through which public and private telecommunications networks can be accessed. The service node also has a WWW interface through which a
15 communication connection to a computer can be established through a data network using the HTTP protocol. The computer is equipped with a WWW browser and receives data in HTML format from the service node. The data is presented on a screen connected to the computer, in the form of pages comprising,
20 among other things, active fields. A user requests a service using said active fields by means of the computer. The service node receives the request for a telephony service or programming of subscriber related data from the computer in

order for the data to be registered by the service node. The service node performs the requested service and sends the result to the computer in a new HTML page, which is presented to the user on the screen.

5

The service node is comprised of a web server, a personal assistant and a service node selector. The personal assistant constitutes a control and supervision part of the service node and communicates both with the service node selector and the web server.

10

The personal assistant handles various subscriber services.

The personal assistant controls the service node selector,

15

which is connected to telecommunications and mobile telecommunications networks.

The personal assistant can, by means of the service node selector, make outgoing calls, receive calls and interconnect incoming and outgoing calls.

20

The personal assistant stores information associated with a user. The user can retrieve and store personal information by

means of a computer telecommunications terminal of his/her choice or.

A user can log in to the service node from a computer with a WWW browser. The web server handles the communication with the computer by transmitting WWW pages in the mark-up language HTML, said pages being presented on the user's computer. The user may enter commands using active fields in the presented HTML page. The commands are transmitted to the web server using the HTTP protocol. The commands are forwarded by the web server to the personal assistant.

The personal assistant makes sure the command is executed. The result is then transmitted to the web server, which generates a new HTML page presenting the result of the command to the user.

The invention makes it possible to simplify the user control of telephony services by means of a computer.

The invention may be utilized by several users as the protocol used for communication with the service node is found in most network connected computers. Programs such as WWW browsers are widely deployed in network connected computers.

The invention enables the storage of data associated with a user in a central node. This data is accessible to the user and may be changed even if the user moves to a different location and uses different terminals. The stored data may be used when a telephone connection with a B subscriber is being set up.

The invention will in the following be described in more detail by way of preferred embodiments and with reference to the enclosed drawings.

BRIEF DESCRIPTION OF THE DRAWINGS

Fig. 1 shows a protocol stack known per se, used in the Internet

15

Fig. 2 shows a schematic block diagram of units comprised in the communication system of which the invention is part.

Figures 3, 4, 5 are sequence diagram of the signalling between the parts of the system.

20

Figure 6 is a flow chart of the method for connection.

DESCRIPTION OF THE ANNEX

The annex contains the complete syntax of the application protocol which constitutes part of the invention.

5 DESCRIPTION OF PREFERRED EMBODIMENTS

The Internet is an important precondition for the applicability of the present invention and will therefore be described briefly here. The Internet in this context means any data network using a protocol stack having an Internet Protocol (IP) layer. Upon the IP another protocol, the Transmission Control Protocol (TCP) is used. These two protocol layers are shown in Figure 1. The IP protocol may be used in different types of physical data networks, hence Figure 1 does not show the protocols below the IP layer. Also, different protocols for different types of applications may be added on top of the TCP layer. Figure 1 shows the HTTP protocol on top of the TCP, since this protocol is used in the application of the present invention.

20 On the HTTP protocol data can be transferred in the mark-up language Hyper Text Meta Language (HTML). In a computer PC, for example, a personal computer or a mainframe computer with user terminals, with WWW browser software, for example Netscape

Navigator or Mosaic, received data is presented according to its HTML format on the screen in the form of pages comprising pictures, graphics and text. The presented HTML pages also comprise so called active fields by means of which the users
5 can request different types of services. The active fields are made up of buttons, fields for entering text, and hypertext links. The user may, for example using a mouse connected to the computer, move a cursor over the page to place it on a button or a hyper text link and then press a mouse button. This will
10 in the following be referred to as clicking a button or a hyper text link, respectively. In this way a command is transferred to another computer, a so called web server connected to the data network, on the HTTP protocol. The command may cause a new HTML page to be transmitted to the user's computer PC where it
15 is presented, or a search for information to be started in a database. The result of said search will be presented to the user on a new HTML page.

Figure 2 is an overview of the communication system in which
20 the method according to the invention is applied. The apparatus according to the invention is comprised of a service node SN.

The service node SN has a WWW interface for communication in data networks using the HTTP protocol. The service node SN has another interface towards a telephone exchange, which is shown in Figure 2 as a private branch exchange PBX, but may also be another type of exchange. Through the exchange PBX connections may be established in public or private telecommunications networks. It is also possible to connect the service node SN directly to a telecommunications network without an exchange therebetween. In the description below only the case in which the communication with a telecommunications network is set up through an exchange is shown. In Figure 2 two public telecommunications networks are shown: a conventional Public Services Telephone Network (PSTN) and a cellular mobile telecommunications network PLMN. It is also possible to connect to other types of telecommunications networks than the ones shown in Figure 2, such as Integrated Services Digital Network (ISDN) or private telecommunications networks. To each of the telecommunications networks a number of telephones, mobile telephones, telefaxes and other types of telecommunications terminal are connected. Figure 2 only shows one telephone AT and one mobile telephone MSA belonging to an A subscriber, and a telephone BT and a mobile telephone MSB belonging to a B subscriber.

The A subscriber also has access to a computer PC. The computer PC may be a personal computer with units for user communication such as a screen, a mouse and a keyboard, or a mainframe computer having a user terminal. The computer is provided with a WWW browser and connected to a data network in which the TCP/IP and HTTP protocols are used, in a conventional way. Figure 2 shows this data network as a cloud referenced as DN.

The service node SN is comprised of three parts: a web server WS, a personal assistant PA and a service node selector SNS.

The web server handles the communication with the computer PC by generating HTML pages, which are then transferred to the computer through the data network DN. The user requests a service using the above described active fields in these pages. When the A subscriber has entered text or clicked a button or a hypertext link, a command specifying the requested service is sent from the computer PC to the web server WS, using the HTTP protocol. The web server transfers the command on to the personal assistant PA. The web server WS and the personal assistant communicate by means of an application protocol. The application protocol uses TCP/IP for transport and thus

constitutes a protocol layer on top of TCP/IP. The protocol implies that commands and other information being exchanged between different computers use an established syntax in order to be interpreted in the same way in the different computers.

5 This means that computers having different operating systems and software written in different programming languages, can communicate with each other. In this way the web server WS and the personal assistant PA, both constituting parts of the present service node, may be computers from different vendors.

10 The complete syntax of the application protocol is described in the annex.

The personal assistant PA is the control unit of the service node. The personal assistant handles the command transmitted

15 from the computer PC and makes sure it is executed. If the command from the computer PC, received by the personal assistant PA implies that a service is to be performed in one of the telecommunications networks PSTN, PLMN, the personal assistant PA orders the service node selector SNS to set up a

20 connection with the appropriate network. The personal assistant then performs the steps required to perform the requested service. The command from the computer PC received by the personal assistant PA may also imply that the personal

assistant PA is to provide or store information, for example programming of user data. When the personal assistant PA has performed, or failed in performing, a requested service, the personal assistant PA transmits the result to the web server, 5 which enters the result into an HTML page and forwards it to the computer PC, which presents it to the A subscriber.

The service node selector SNS is able to set up connections to the telecommunications networks PSTN, PLMN, upon orders from 10 the personal assistant PA. The service node selector is also able to connect to existing connections, upon orders from the personal assistant. As described below, this function will be utilized in the present method.

15 The commands exchanged between the computer PC, the telephone AT of the A subscriber, the web server WS of the service node, the personal assistant PA of the service node, the service node selector SNS of the service node, the private branch exchange PBX, the public network PSTN and the telephone BT of the B 20 subscriber, when a service is requested by the A subscriber, are shown in Figures 3, 4 and 5.

Figure 3 shows the login procedure to the service node SN. The user has first retrieved a presentation page from the service node SN, using his computer PC. In this page, the user enters his identity and password in fields intended for this
5 information. This data is then transmitted to the web server WS with a login request. The request is approved after the web server has checked and verified the identity and password by a query to the personal assistant PA. The web server WS then transmits a new page to the computer PC comprising an index of
10 available services and data, a so called index page.

In the obtained index page, the user clicks on a hypertext link to request user programming in the personal assistant PA.

Programming of user data involves the A subscriber changing or
15 adding information related to the user, which is stored in the personal assistant PA. Programming of user data is necessary for the personal assistant to know what telecommunications terminal the A subscriber intends to use. If the A subscriber wishes to change the telecommunications terminal, this is done
20 by reprogramming the user data in the personal assistant. The A subscriber can also register the names and identities of other telecommunications subscribers, with photos if desired, to facilitate the ordering of telephone services. This data can

thus constitute a personal telephone directory for the A subscriber. It is also possible to register telecommunications commands in the personal assistant to facilitate their use.

Names, identities and other information registered can be used
5 as hypertext links or active fields, when presented to the user on an HTML page, to facilitate making calls or using the data in another way.

Figure 4 shows signal sequences in user programming when the A
10 subscriber changes his own telephone AT. The request is transferred through the data network DN to the web server WS which in turns forwards the request to the personal assistant PA. The personal assistant, in which the user data is stored, transmits a set of parameters to the web server WS. The web
15 server enters the parameters into an HTML page and transmits the page to the computer PC. In the present example the A subscriber wishes to change his telephone. If the identity of the new telephone is already stored in the personal assistant PA and registered on the parameter page, the A subscriber can
20 enter a new telephone by, for example, clicking on the hypertext link of the new telephone. If the telephone to which the A subscriber wishes to change is not registered, the identity of the new telephone, the A number, is entered in a

field intended for this information on the parameter page. The request for a new A number is received by the web server WS, which forwards the request to the personal assistant PA. The personal assistant registers the new A number and then

5 transmits a new set of data to the web server. The web server WS enters this data in a new parameter page in HTML format which is transmitted to the computer PC. The telephone to which the service node SN will connect the A subscriber's calls is then presented to the A subscriber on the screen of the

10 computer PC.

The A subscriber can retrieve the index page stored in the computer PC after login. The user requests the set-up of a telephone connection between his own telephone AT and a B

15 subscriber's telephone, for example by typing in the B number in a field on the index page intended for this information. It is, however, easier for the user if the B number is already stored in the above described personal telephone directory. The telephone directory may either have come with the index page or

20 be retrieved to the computer PC in HTML format from the personal assistant PA through the web server WS in the same way as the data page. From the telephone directory the A subscriber requests a call by, for example, on his computer, clicking on a

hypertext link with the B subscriber's name. Figure 6 shows the procedure when a call is made. In the first block 1 the A subscriber requests the B subscriber to be called, from his computer PC, in any of the above described ways. Figure 5 shows the signalling sequence when a call is made. The request to call the B subscriber is transferred from the computer PC to the web server WS, which forwards the request to the personal assistant PA, which is also shown in step 2 in Figure 6.

10 The personal assistant PA orders the service node selector SNS to call the A subscriber's telephone AT. The service node selector calls the telephone AT through the exchange PBX and the public network PSTN, corresponding to step 3 in Figure 6.

15 When the A subscriber has answered, by lifting the hook of the telephone AT, step 4, the connection is set up between the personal assistant and the A subscriber through the public telecommunications network PSTN, the exchange PBX and the service node selector SNS. The personal assistant PA then

20 orders the service node selector to call the B subscriber's telephone BT. The service node selector SNS sets up a connection to the B subscriber's telephone in the same way as with AT, as represented by step 5. When the B subscriber has

answered, in step 6, the personal assistant PA orders the service node selector SNS to connect the two connections. In this way a connection between the two telephones AT and BT is established, see step 7 in Figure 6.

5

The procedure would have been interrupted after a certain period of time if one of the parties had not answered, see steps 4 and 6. The personal assistant PA transfers the result of the set-up, or the failed set-up, to the web server WS,
10 which transfers it, in HTML format, to the computer PC, where it is presented to the A subscriber. This is shown in the final step 8 in Figure 6.

The method for connection set-up described above can also take
15 place in modified ways. The set-up of connections for calling the A subscriber and the B subscriber, respectively, can take place in a different order than the one described above, and independently of whether or not the other party has answered the call. Interconnection of the two connections can be made
20 even if one of the parties has not answered the call.

For example, in a modified embodiment, the connection between the service node and a B subscriber may be established

independently of whether or not the call made to the A subscriber's telephone was answered.

The method can also be modified to let the B subscriber be
5 called before the A subscriber.

In another modified embodiment the connection to the A subscriber and the connection on which the B subscriber's telephone is being called, are interconnected.

10

A further modification, for the case when the B subscriber answers the call first, consists of the service node interconnecting the connection to the B subscriber and the connection on which the A subscriber's telephone is being
15 called. For the cases when the B subscriber is the first to answer the call, the service node provides a spoken message that a call is being made from another subscriber.

The service node SN also handles incoming connections to the A
20 subscriber if call forwarding has been set up from the called identity to the service node SN.

The A subscriber can, in the desired order and after logging in to the service node SN, reprogram user related data or request a telecommunications service, such as call set-up. Other telecommunications services handled by the service node SN are, 5 for example, electronic mail, transmission or reception of telefax, whereby the service node functions as a mailbox for e-mail, fax and voice messages.

CLAIMS

1. A method for setting up a telecommunications connection between a calling A subscriber and a B subscriber through a telecommunications network (PSTN, PLMN) by means of a computer (PC) available to the A subscriber and provided with a WWW browser, said computer having access to a service node (SN) through a network in which the HTTP protocol is used, said service node receiving and processing orders for telephony services and for the registration of subscriber data and said A subscriber having access to at least one telecommunications terminal connected to the telecommunications network (PSTN, PLMN),
- 15 characterized by the steps of
- a) transmitting, on request, a set of data in the HTML format from said service node (SN) to the A subscriber's computer (PC), said data comprising an offer to call the B subscriber by means of the B subscriber's identity;
- 20
- b) presenting the set of data as an HTML page;

c) requesting a call to said B subscriber by seeking access to said identity;

d) transmitting said call request by means of the A

5 subscriber's computer to said service node and by means of said HTTP protocol, said service node receiving said call request and forwarding it within the node by means of an application protocol (AP);

10 e) setting up a first connection, in reply to said call request, between the service node (SN) and the telecommunications network (PSTN, PLMN), said service node requesting a call to said telecommunications terminal (AT) used by the calling A subscriber;

15

f) setting up a second connection between said service node (SN) and the telecommunications network (PSTN, PLMN), said service node requesting a call to the B subscriber's telecommunications terminal;

20

g) interconnecting the connections established according to e) and f) when at least one of the called A and B subscribers has

answered the call, for connection between said A and B subscribers.

2. A method according to claim 1, **characterized** in that a
5 second connection according to f) is not set up until the A subscriber has answered said call.

3. A method according to claim 2, **characterized** by setting up
both connections only after the B subscriber has answered the
10 call.

4. A modified method according to claim 1, **characterized** in
that the setting up of said first connection takes place
according to e) but that the call is requested to the B
15 subscriber's terminal and that the setting up of said second connection takes place according to f) but that the call is requested to the A subscriber's terminal.

5. A method according to claim 1 or 4, **characterized** by
20 interconnecting the two connections only after the A subscriber has answered the call.

6. A method according to claim 1 or 4, **characterized** in that before the call is requested by the A subscriber according to step c), the A subscriber has registered data in the service node, by performing the following steps:

5

a) transmitting a request for the programming of user data by means of the A subscriber's computer (PC) to the service node (SN) through the HTTP protocol;

10 b) forwarding said request for programming within the service node (SN) through the application protocol, and subsequently processing said request;

15 c) transmitting a set of user related data within the service node (SN) through the application protocol, and subsequently forwarding said set of data according to the HTTP protocol through a data network (DN) to the A subscriber's computer (PC);

20 d) presenting the set of user related data in the form of an HTML page on a screen connected to said computer (PC), said A subscriber entering the command using active fields in the HTML

page presented on screen, to add the new data entered by the A subscriber to the previously stored user data;

e) transmitting the command described in d), and transmitting
5 the data listed in d), to the service node, by means of the computer (PC) and by means of the HTTP protocol, forwarding said command and said data within the service node through the application protocol (AP) and subsequently registering said data.

10

7. A method according to claim 6, **characterized** in that the command entered by the A subscriber under d) provides an instruction as to what telecommunications terminal the A subscriber intends to use.

15

8. A method according to claim 7, **characterized** in that the identity of said telecommunications terminal has been previously registered in the service node (SN) upon a command from the A subscriber.

20

9. A method according to claim 6, **characterized** by transmitting the identity of said terminal with said command for registration in the service node (SN).

10. A method according to claim 6, **characterized** in that the command entered by the A subscriber under d) comprises data about the identity of the B subscriber.

5

11. A method according to claim 1, 4 or 6, **characterized** in that the A subscriber logs in to the service network SN using a password (by typing it in a field intended for this information on an HTML page) before the request to call the B subscriber, or the user programming, can be processed.

10

12. A method according to claim 1 or 4, **characterized** in that the service node (SN), after receiving and processing a request for connection, transfers the result of the set-up procedure to the computer (PC) in an HTML format.

15

13. A service node (SN) constituting a link between a computer network, in which the HTTP protocol is used, and at least one telecommunications network, said service node being used to request a telecommunications service from an A subscriber's computer (PC) through the data network, **characterized** in that the service node (SN) comprises:

20

a) a web server (WS) for the communication with said computer through the computer network using the HTTP protocol;

b) a service node selector (SNS) connected to at least one
5 telecommunications network (PSTN, PLMN) to set up two separate connections in the telecommunications network, one of which connects a telecommunications terminal belonging to the A subscriber and the other connecting a telecommunications
terminal belonging to a B subscriber, in order to subsequently
10 interconnect the two connections;

c) a personal assistant (PA) having a communication connection to the web server (WS) and a communication connection to the service node selector (SNS), said personal assistant
15 constituting the unit handling the request for a communication service and ensuring it is performed by controlling the service node selector (SNS).

14. A service node according to claim 13, **characterized** in that
20 the personal assistant comprises a memory space for storing user related data.

15. A service node according to claim 14, **characterized** in that memory space of the personal assistant is used for storing the identity of the A subscriber's terminal, to enable the establishment of a telecommunications connection with the A
5 subscriber's terminal.

16. A service node according to claim 13, **characterized** in that the memory space of the personal assistant is used for storing the identity of the B subscriber's terminal, to enable the
10 establishment of a telecommunications connection with the B subscriber's terminal.

1/5

HTTP
TCP
IP

Fig 1

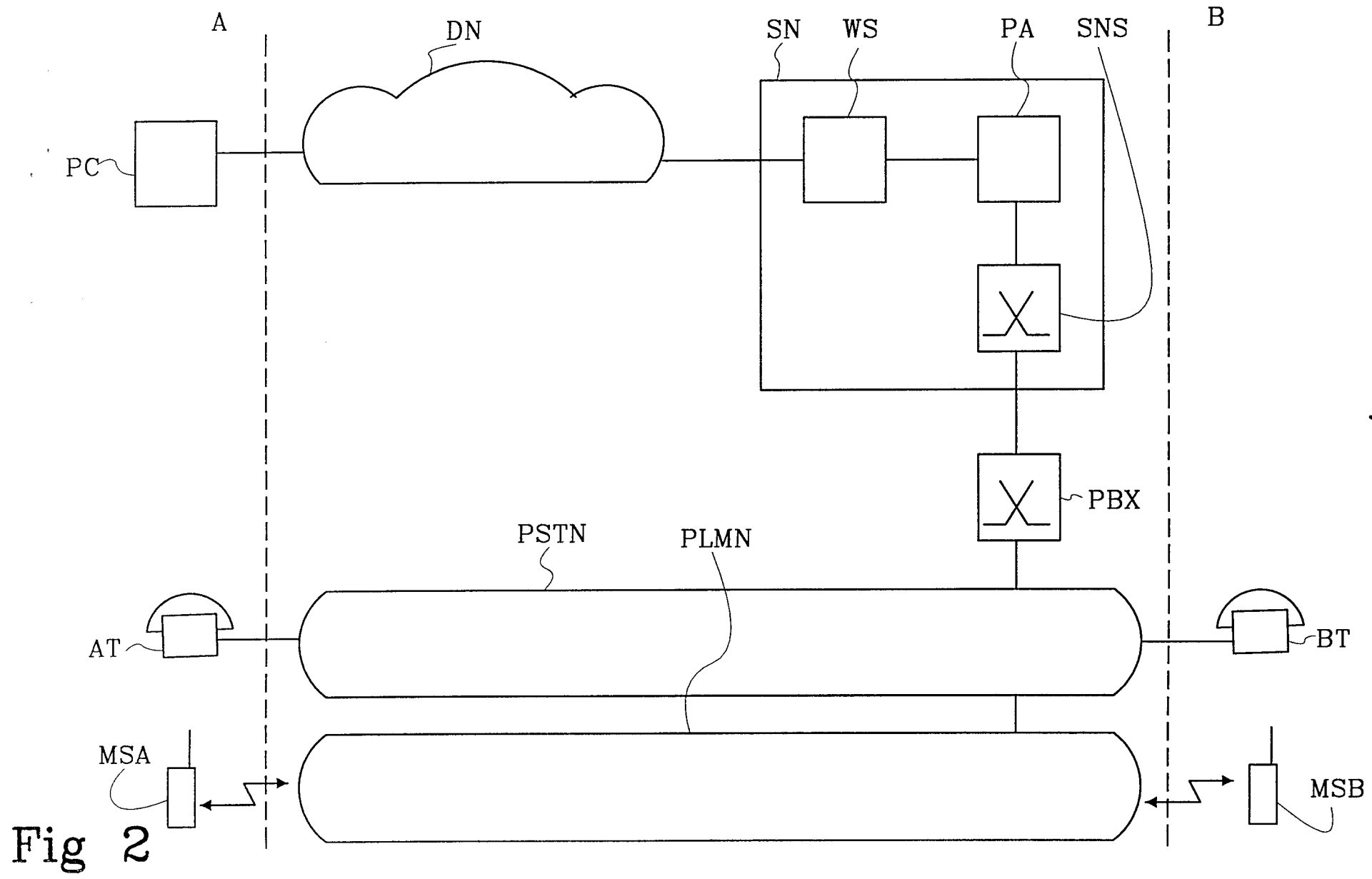

Fig 2

Login to SN

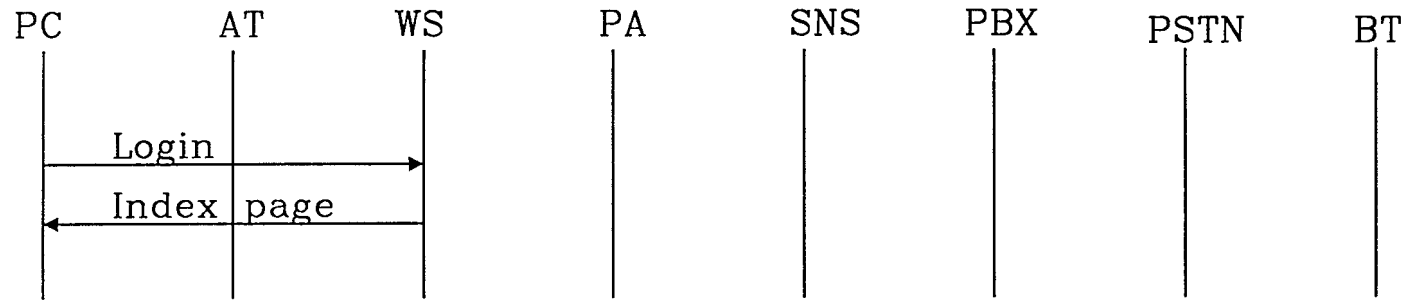

Fig 3

User programming

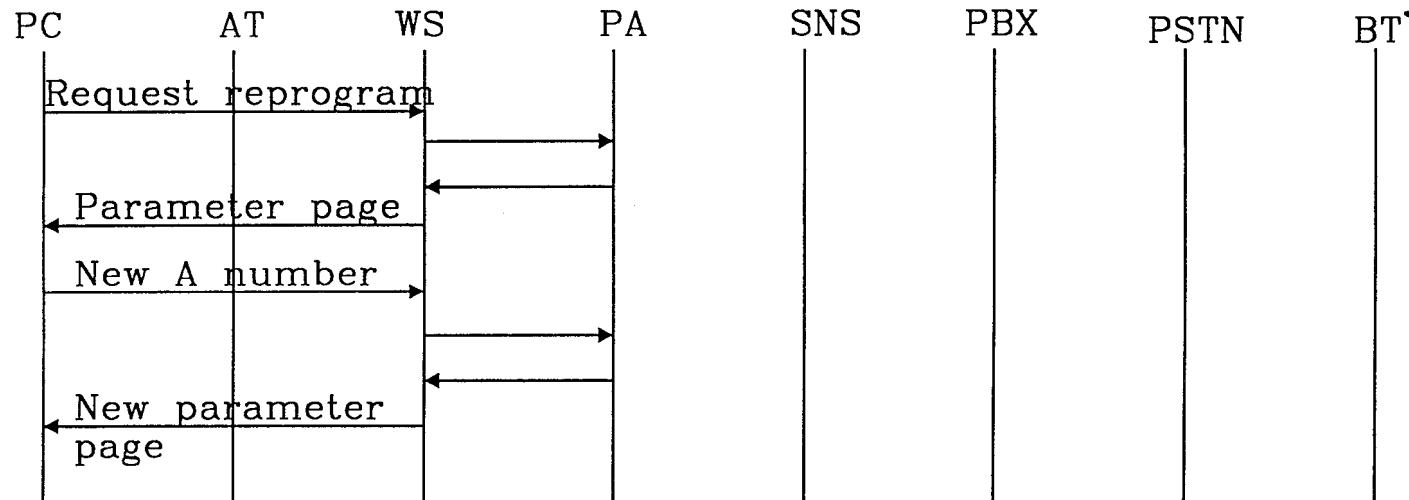

Fig 4

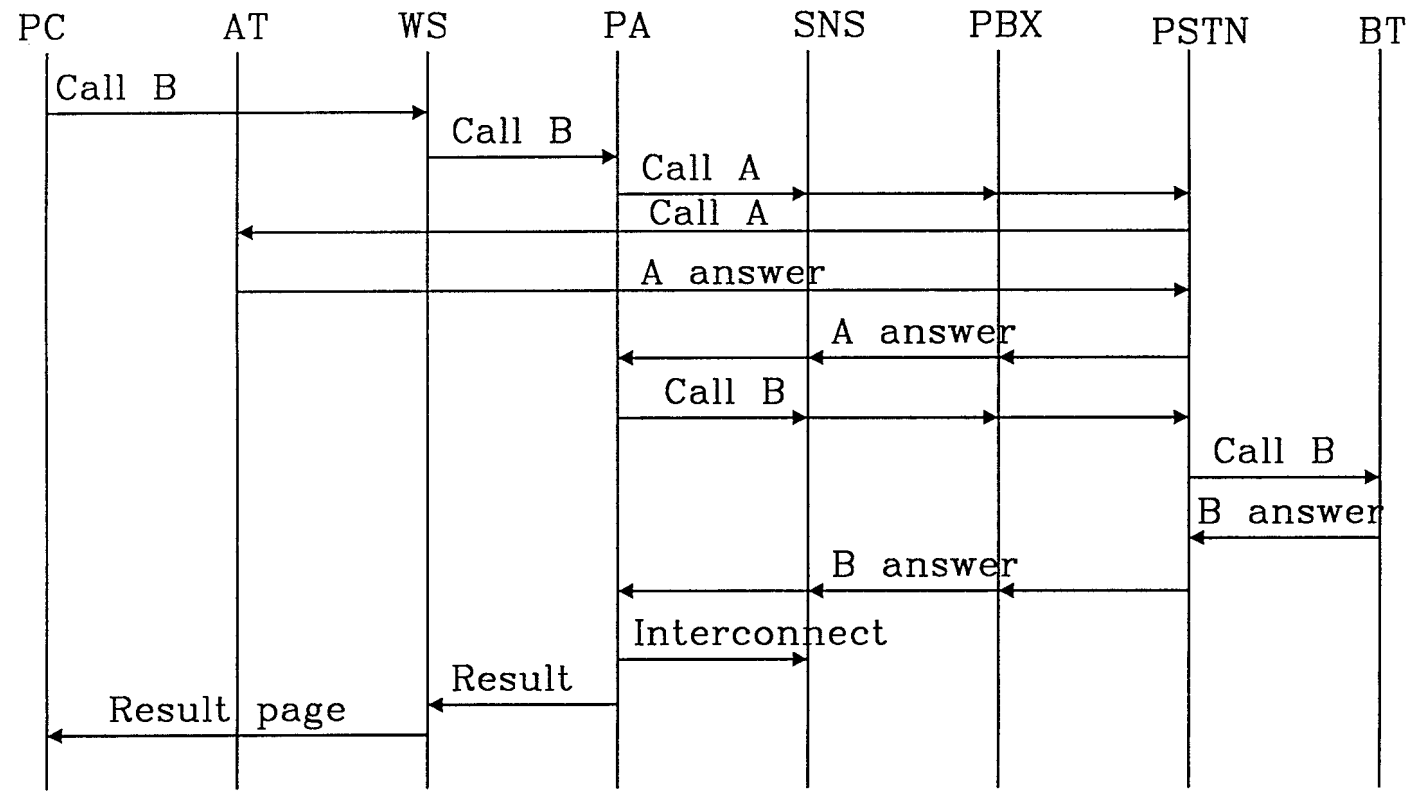

Fig 5

5/5

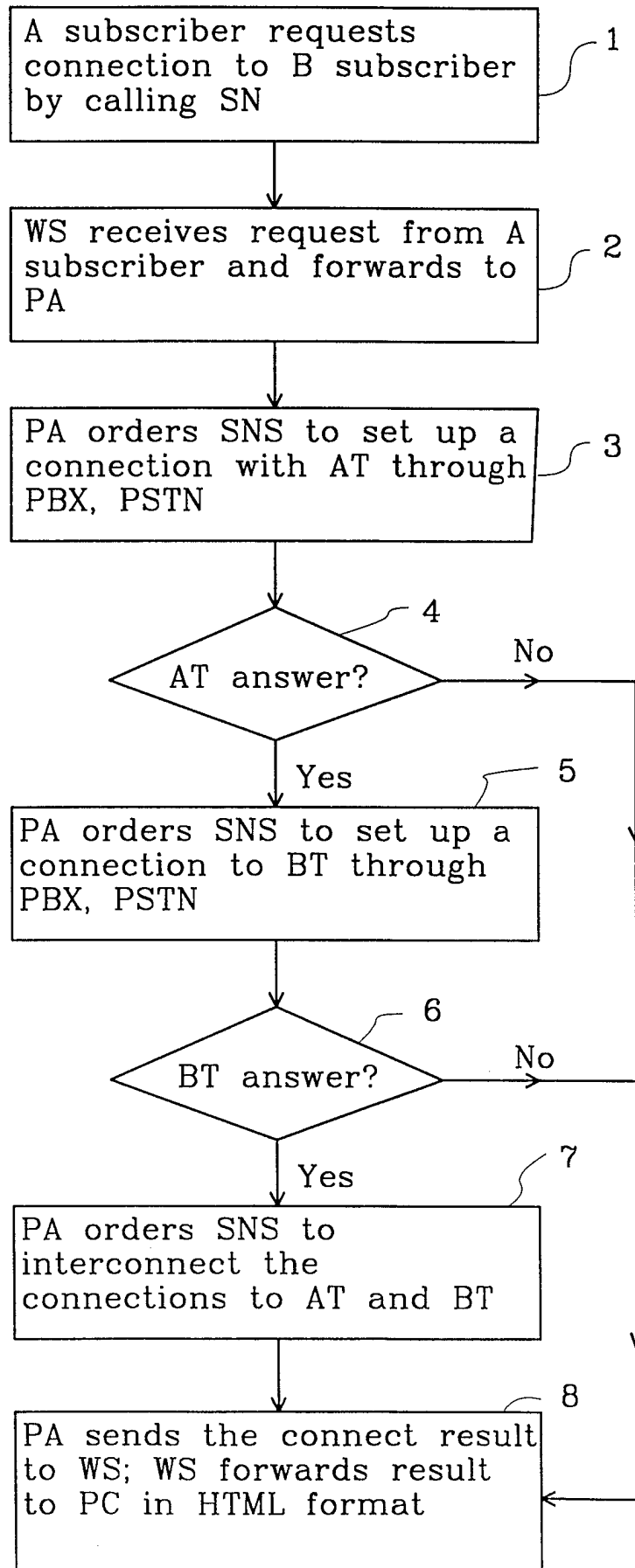

Fig 6

INTERNATIONAL SEARCH REPORT

International application No.

PCT/SE 97/01719

A. CLASSIFICATION OF SUBJECT MATTER		
IPC6: H04M 11/00, H04M 1/26, H04M 3/42, H04L 29/06 According to International Patent Classification (IPC) or to both national classification and IPC		
B. FIELDS SEARCHED		
Minimum documentation searched (classification system followed by classification symbols)		
IPC6: H04M, H04Q, H04L		
Documentation searched other than minimum documentation to the extent that such documents are included in the fields searched		
SE,DK,FI,NO classes as above		
Electronic data base consulted during the international search (name of data base and, where practicable, search terms used)		
EDOC, WPIL, INSPEC		
C. DOCUMENTS CONSIDERED TO BE RELEVANT		
Category*	Citation of document, with indication, where appropriate, of the relevant passages	Relevant to claim No.
X	GB 2254981 A (GPT LIMITED), 21 October 1992 (21.10.92), column 2, line 19 - line 33; column 4, line 13 - line 16; column 4, line 23 - line 35, column 6, line 6 - line 11, column 5, line 6 - line 28	1-5, 12, 13
Y	--	6-11, 14-16
Y	DE 4101885 A1 (STANDARD ELEKTRIK LORENZ AG), 30 July 1992 (30.07.92), column 2, line 45 - column 3, line 7	6-11, 14-16
	--	
<input checked="" type="checkbox"/> Further documents are listed in the continuation of Box C. <input checked="" type="checkbox"/> See patent family annex.		
* Special categories of cited documents: "A" document defining the general state of the art which is not considered to be of particular relevance "E" earlier document but published on or after the international filing date "L" document which may throw doubts on priority claim(s) or which is cited to establish the publication date of another citation or other special reason (as specified) "O" document referring to an oral disclosure, use, exhibition or other means "P" document published prior to the international filing date but later than the priority date claimed "T" later document published after the international filing date or priority date and not in conflict with the application but cited to understand the principle or theory underlying the invention "X" document of particular relevance: the claimed invention cannot be considered novel or cannot be considered to involve an inventive step when the document is taken alone "Y" document of particular relevance: the claimed invention cannot be considered to involve an inventive step when the document is combined with one or more other such documents, such combination being obvious to a person skilled in the art "&" document member of the same patent family		
Date of the actual completion of the international search		Date of mailing of the international search report
11 February 1998		12 -02- 1998
Name and mailing address of the ISA/ Swedish Patent Office Box 5055, S-102 42 STOCKHOLM Facsimile No. +46 8 666 02 86		Authorized officer Emil Dautovic Telephone No. +46 8 782 25 00

INTERNATIONAL SEARCH REPORT

International application No.

PCT/SE 97/01719

C (Continuation). DOCUMENTS CONSIDERED TO BE RELEVANT

Category*	Citation of document, with indication, where appropriate, of the relevant passages	Relevant to claim No.
A	<p>Högskolan i Luleå, Luleå University, Sweden 27/3 1995 Functional Distribution between Cooperating Networks, Mikael Andreasson et al Examensarbete/Master Thesis see chapter 3.1,3.2 and chapter 6.1-6.3 cited in the application</p> <p style="text-align: center;">-- -----</p>	1-16

INTERNATIONAL SEARCH REPORT

Information on patent family members

03/02/98

International application No.

PCT/SE 97/01719

Patent document cited in search report	Publication date	Patent family member(s)	Publication date
GB 2254981 A	21/10/92	DE 4212102 A	05/11/92
DE 4101885 A1	30/07/92	NONE	