

[72] **Inventors** Alan L. Litman
 Pittsburgh, Pa.;
 Dennis K. Hackbarth, Lima, Ohio; Robert
 R. Hayes, Cleveland, Ohio

[21] **Appl. No.** 858,355

[22] **Filed** Sept. 16, 1969

[45] **Patented** Aug. 31, 1971

[73] **Assignee** General Ordnance Equipment Corporation
 Pittsburgh, Pa.

[56] **References Cited**

UNITED STATES PATENTS

2,530,583	11/1950	Nurkiewicz	222/472
2,653,667	9/1953	Genin et al.	222/79

Primary Examiner—Robert B. Reeves
Assistant Examiner—James M. Slattery
Attorney—Patrick J. Walsh

[54] **NON-LETHAL WEAPON DISPENSER**
 12 Claims, 8 Drawing Figs.

[52] **U.S. Cl.**..... 222/153,
 222/470, 222/473, 222/79, 222/325

[51] **Int. Cl.**..... B67d 5/32

[50] **Field of Search**..... 222/147,
 153, 142.1, 470, 472, 473, 474, 394, 79, 325,
 400.7

ABSTRACT: This invention relates generally to hand operated dispensers for spraying liquids from pressurized containers and is particularly concerned with such dispensers that are adapted to be carried by the user, and that provide means for more accurately directing the spray as well as providing a number of safety features preventing accidental or other discharge of fluid when not desired.

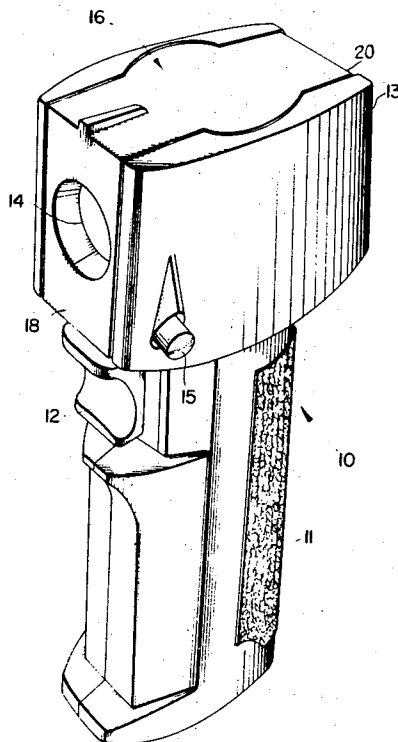

FIG. 1

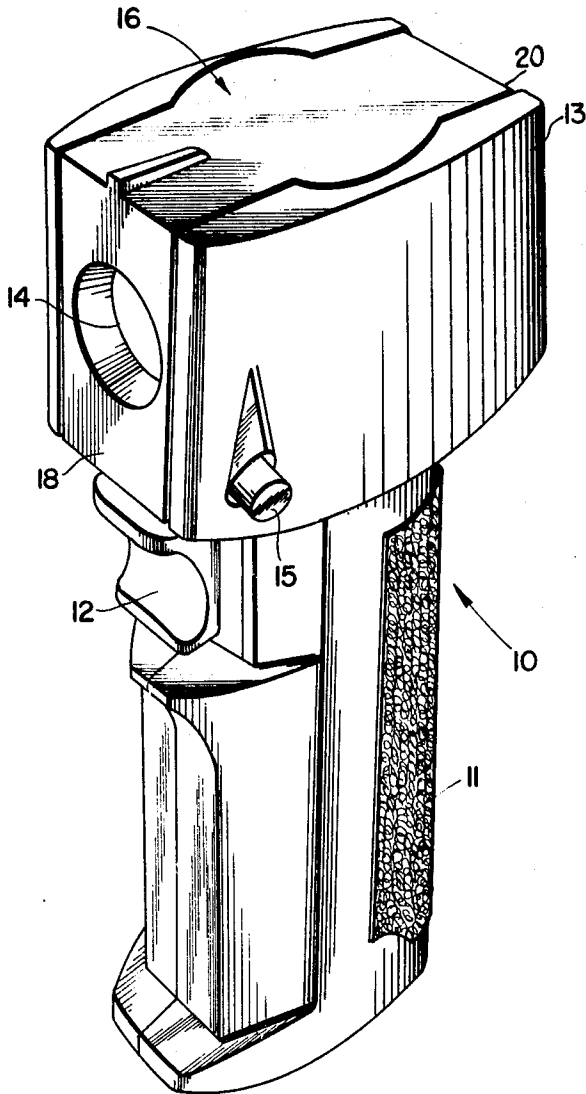

FIG. 2

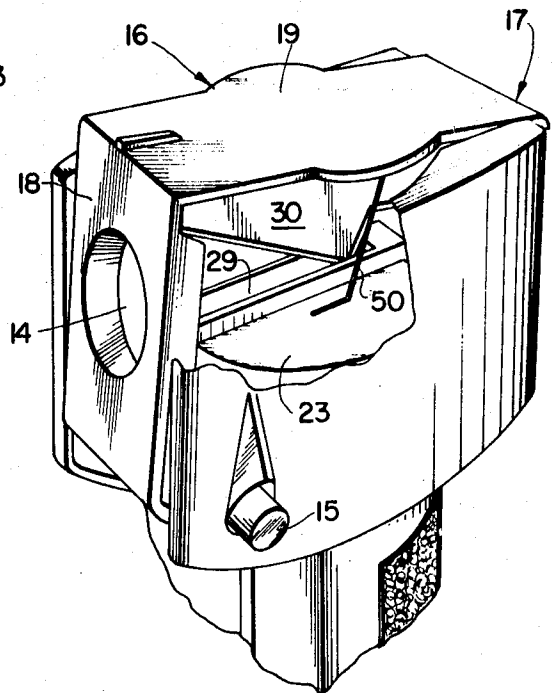

FIG. 4

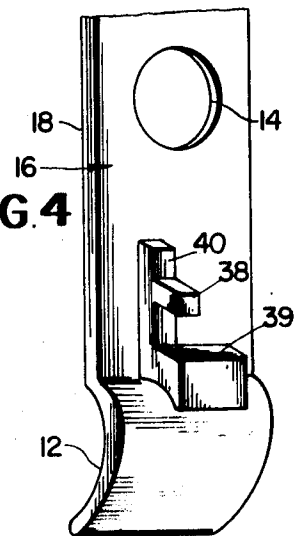
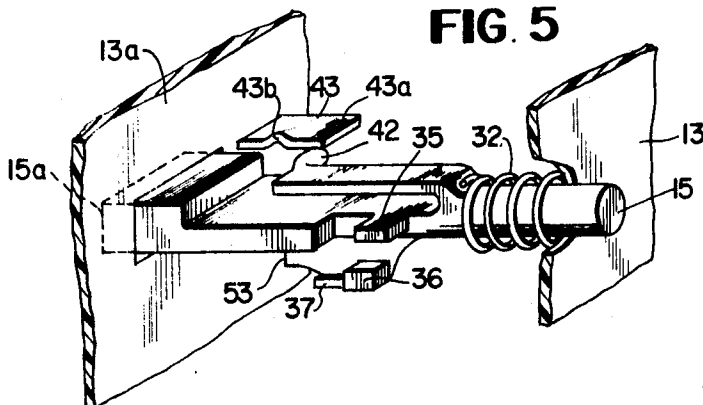

FIG. 5



INVENTORS
ALAN L. LITMAN
DENNIS HACKBARTH
ROBERT R. HAYES

BY *Paris, Hubbell & Lewis*
ATTORNEYS

FIG. 3

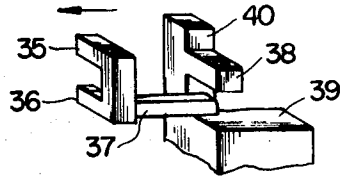
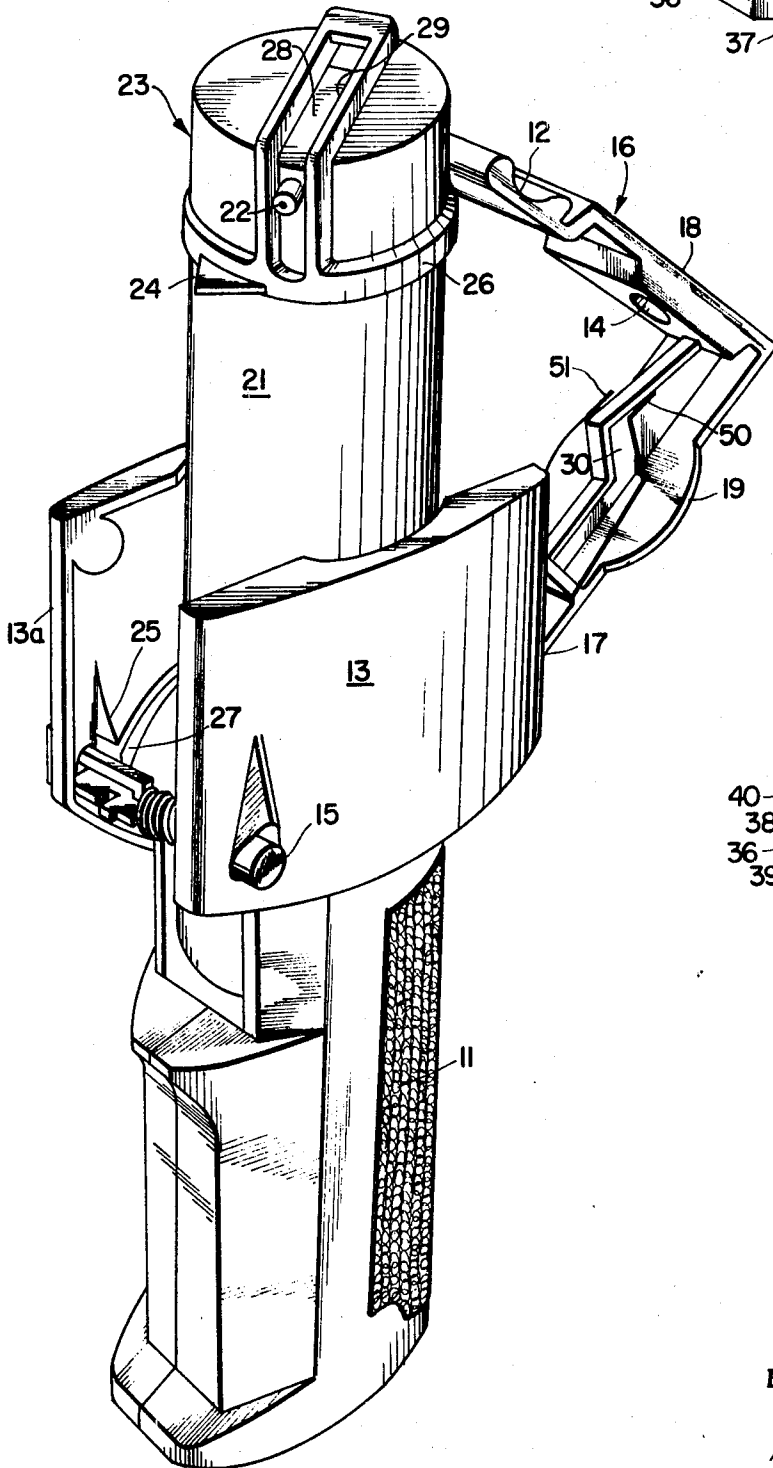

FIG. 6

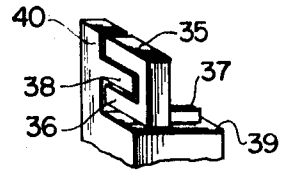

FIG. 7

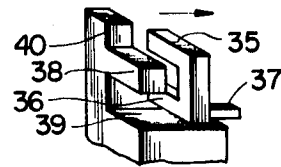

FIG. 8

INVENTORS
ALAN L. LITMAN
DENNIS HACKBARTH
ROBERT R. HAYES
BY

Haus, Lupell & Kearns
ATTORNEYS

NON-LETHAL WEAPON DISPENSER

STATEMENT OF THE PRIOR ART

Many liquids and gases are today packaged in pressurized spray containers ranging from such materials as paints, cosmetics, and the like to nonlethal weapons, that provide a liquid stream of lacrymating irritant. These latter devices are often carried by police officers in belted holsters and are withdrawn and used under emergency conditions to temporarily subdue law violators.

Particularly for such police uses as well as many others, it is desired that the pressurized liquid stream be provided from a dispenser that can be accurately aimed and directed at a selected target, both in darkness and in semidarkness, and often under emergency conditions wherein the police officer must rapidly withdraw the dispenser from its holster, aim, and spray an assailant in the shortest possible time.

Additionally for such uses, the pressurized irritant must be so housed in the dispenser that it cannot be fired or triggered by dropping it or striking it by some foreign object, or during replacement of the pressurized cartridge, or under other conditions when not desired, since such accidental discharge might result in the police officer or some innocent party being unintentionally sprayed with the lacrymating ingredients.

Presently available and known pressure spray dispensers do not provide these advantages or the safety features necessary to prevent unwanted discharge and operation of the device as would be desired by the police. Therefore, it is a primary object of this invention to provide such a dispenser having these features at a sufficiently low cost that is well within the tax supported budgets of Police Departments and police officers.

SUMMARY OF THE INVENTION

According to the present invention, there is provided a lightweight and portable dispenser for pressurized fluids that is generally in the form of a hand operated weapon, such as a handgun, and that is adapted to incorporate a removable, cylindrically shaped container or cartridge of pressurized fluid that is adapted to incorporate a removable, cylindrically shaped container or cartridge of pressurized fluid that is substantially completely enclosed and protected within the dispenser. The dispenser includes a trigger-like lever at its forward side that is adapted to be squeezed by the finger to actuate the valve of the enclosed pressurized cartridge and accordingly direct the liquid spray forwardly from the dispenser. The shape and arrangement of the hand gripping portion of the dispenser and of the triggering lever are such as to be easily accommodated within the hand in only one orientation with the spray nozzle portion being directed forwardly away from the user. For this reason, when the weapon is withdrawn from its holster it will be automatically aimed or directed in the forward direction away from the user in the same manner as pointing a finger and unlikely to spray the user or some innocent person even under emergency conditions.

The dispenser incorporates means for easily and removably locking the cartridge inside the hand gripping portion and provides means associated with the trigger lever for actuating the valve of the cartridge to initiate the spray discharge. The valve of the cartridge is enclosed within a protective cover and not otherwise easily actuated and the cartridge is completely closed within the dispenser, whereby the triggering mechanism on the dispenser provides substantially the only manner of discharging the spray.

To protect against unwanted discharge should the dispenser or its trigger be struck with a foreign object, or should the dispenser be dropped, the dispenser incorporates a novel slidable three-way safety mechanism that is easily operated by the finger of the user in a manner similar to the "safety" of a handgun.

In one position of the safety mechanism, the dispenser may be opened to remove and replace the cartridge but in that position the dispenser may not be fired or actuated to accidentally discharge a spray.

In a second or full "safety" position of the mechanism, that is normally used where the weapon is holstered, the dispenser may not be opened nor may it be fired.

In the third and final position of the "safety," the dispenser may be fired but may not be opened. This is normally the operating mode for use of the weapon.

As an additional feature of the invention, inexpensive means are provided for enabling the user to rapidly determine the remaining contents in the cartridge so as to be aware in advance whether a replacement cartridge should be inserted into the dispenser.

THE DRAWINGS

FIG. 1 is a perspective view illustrating a preferred dispenser according to the present invention,

FIG. 2 is a portion of a perspective view, similar to FIG. 1, but partly in section and illustrating the trigger lever partially in open position,

FIG. 3 is a perspective view, similar to FIG. 1, and showing the trigger lever in full open position and the cartridge partially removed,

FIG. 4 is a schematic perspective view of the underside of the trigger lever showing the construction of fixed portions of the safety mechanism adapted to interengage with the safety slide member in FIG. 5,

FIG. 5 is a perspective view of the safety slide member, and FIGS. 6, 7, and 8 are diagrammatic views illustrating the interaction of the safety slide mechanism with the complementing portions on the trigger lever for each of the three modes of operation.

DETAILED DESCRIPTION

Referring to the drawings, and initially to FIGS. 1 and 2, the dispenser 10 is provided with a hollow hand gripping portion 11 to be accommodated within the hand of the user and encircled by the fingers. A recessed portion on the handle near the forefinger, accommodates the finger operated trigger 12 located at the front of the handle portion. Above the hand gripping portion 11, there is provided an enlarged head portion 13 having a forwardly directed opening 14 located above the trigger 12, and with the head portion accommodating a reciprocally slideable "safety" member having buttonlike projections 15 and 15a passing through opposite sides of the head portion 13 and easily engageable on either side of the head portion 13 by the same fingers that grasp the hand portion 11.

As best shown in FIGS. 2 and 3, the trigger 12 is preferably an integral part of an L-shaped trigger lever 16 that is pivotally connected at the rear of the head portion 13 at position 17, which lever in its closed position, as shown in FIG. 1, forms a major portion of the front face 18, the top face 19, and the rear face 20 of the head portion 13. When the lever is pivoted in its rearwardly open position shown in FIG. 3, it provides an enlarged opening at the top of the dispenser to receive a cylindrically shaped pressurized container 21 or cartridge carrying the pressurized fluid. The cartridge 21 is adapted to be inserted and removed through this opening in the top of the dispenser, as shown in FIG. 3, and to be placed downwardly and accommodated inside of the hollow handle or gripping portion 11 of the dispenser.

The front face 18 of the trigger lever includes the forwardly facing hole or opening 14 permitting a jet spray emitted by the nozzle 22 of the cartridge to be discharged through this opening 14 of the dispenser.

The cartridge 21 is provided with a specially configured cap 23 that provides a number of functions; including aligning the spray nozzle 22 of the cartridge with the forwardly facing opening 14 in the trigger lever 16. It also serves the function of detachably locking the cartridge inside of the hollow handle portion 11 of the dispenser.

For aligning and locking the cartridge 21, the cap 23 is provided with an outwardly projecting lip 24 that is adapted to engage with and be locked by an inwardly projecting shoulder 25 formed on the inside wall of 13a of the head of the dispenser.

For proper insertion, the cartridge 21 is placed downwardly into the hollow handle portion 11 with its lip 24 facing the front opening, and is lowered until a flange 26 at the base of the cap 23 strikes and rests on a rim 27 provided on the inside wall of the dispenser and projecting radially inward. The cartridge 21 is then rotated or pivoted for a partial turn wherein the lip 24 on the cap 23 passes between the shoulder 25 and the rim 27 that is spaced below the shoulder. This locks the cartridge 21 inside the dispenser and also aligns the nozzle 22 of the cartridge with the opening 14 in the trigger lever 16. The lip 24 on the cap 23 projects sufficiently outwardly and is pointed at its end so that it strikes the inner wall 13a of the dispenser when the nozzle 22 is properly oriented, thereby preventing further rotation of the cartridge 21 within the dispenser and maintaining the nozzle 22 properly facing forward.

With the exception of the cap 23, the pressurized cartridge 21 is of a conventional type having a conventional inner valve (not shown) that is operated by a downward displacement of the valve actuator 28 at the top of the cartridge 21. The outer cap 23 over the cartridge 21 completely covers the valve actuating portion 28 of the cartridge except for an L-shaped slit 29 providing a narrow opening at the top and front face to the cartridge 21. The forward front face slit opening portion provides outward access for the spray from nozzle 22, and the slit opening through the cap at the top provides the opening for applying a member into the cap to operate the valve of the cartridge for spraying.

For actuating the valve of the cartridge 21 to emit a spray, the underside of the trigger lever 16 is provided with a narrow projecting ridge member 30 having a pointed tip and being of slightly less width than the slit 29 through the cartridge cap 23. As best shown in FIG. 2, when the trigger lever 16 is rotated to a closed position, the tip of the ridge 30 enters the slit 29 in the cartridge cap 23 and continued down movement of the trigger lever 16 applied by gently squeezing the trigger 12 causes the tip of the ridge member 30 to press downwardly on the valve operator 28, of the cartridge to operate the valve, thereby to emit a spray through the nozzle. These parts are so proportioned that the rotation of the trigger lever 16 to the closed position shown in FIG. 1 positions the pointed tip of ridge 30 immediately above the top face 28 of the cartridge; and further rotation, downwardly and inwardly of the trigger lever 16, by squeezing the trigger portion 12 is required to actuate the cartridge valve mechanism.

To prevent the accidental or other firing of the weapon during loading or unloading of the cartridge, or when it is dropped or struck by a foreign object; or at any time when it is not desired to be fired, the dispenser 10 is provided with a three-way safety lock mechanism that is controlled by a reciprocally moveable safety slide member 15—15a passing through the sides 13, 13a on the upper portion of the dispenser. This slide is located immediately above the trigger 12 at the front of the dispenser as shown in the drawings.

As best shown in the enlarged view in FIG. 5, the safety slide is a horizontally disposed member having one end of circular cross section 15 projecting through a circular opening in one wall 13 of the dispenser 10 and its opposite end 15a being of rectangular cross section and projecting through a rectangular opening in the other spaced wall 13a. A spring 32 about the circular end of the slide member, has one end bearing against the inside of the wall 13 and its other end bearing against portions of the slide to urge the slide to the left, as viewed in FIG. 5. This urges the slide to its "locked" or normal position wherein the trigger lever 16 is locked and prevented from either firing the cartridge or from rotating to the open position of FIG. 3. This is the normal position of the slide when carrying the dispenser in a holster, or when storing it so that it cannot be fired accidentally or otherwise.

After the weapon is withdrawn from its holster, and the police officer desires to fire it, he merely raises his thumb from the handgrip portion of the dispenser 11 where it normally rests and depresses the circular portion of the slide to the left

as viewed in FIG. 5. This places the safety mechanism in the "ready" or "fire" position to fire whenever the trigger 12 is squeezed. As will be recalled, squeezing the trigger 12, rotates the trigger lever 16 slightly downwardly and inwardly to fire a spray from the cartridge by operating the cartridge valve as discussed above. This "fire" position, however, prevents rotation of the trigger lever 16 upwardly so that the trigger lever 16 cannot be accidentally or otherwise opened to the position shown in FIG. 3.

In the third and final position of the safety slide, the user can reciprocate the safety slide far to the right, as viewed in FIG. 5, by depressing the opposite square shaped end 15a of the safety slide. Movement of the slide to the right by a sufficient distance releases the trigger lever 16 permitting it to be rotated upwardly for removing and replacing the cartridge 21. However this position of the safety slide prevents rotation of the trigger lever 16 downwardly so that the weapon cannot be accidentally operated or fired when it is being opened for replacing the cartridge.

FIGS. 4 and 5 illustrate in enlarged form, the interacting parts of the reciprocally moveable safety slide and the interacting portions of the trigger lever 16 to effectuate these three modes of operation. As shown in FIG. 5, the central portion of the safety slide includes two outwardly facing spaced projection members 35 and 36 positioned one above the other and providing a C-shaped configuration, and includes a third projecting portion 37 disposed longitudinally adjacent the projecting member 36. As schematically shown in FIG. 4, the underside of the trigger lever 16 also includes a pair of inwardly spaced projecting members 38 and 39 at a position located above the trigger portion 12. The upper inwardly projecting member 38 on the trigger lever is of generally square shaped cross section as shown, and the lower member 39 is of rectangular configuration that is considerably wider than member 38 but projects inwardly for essentially the same distance. The lower member 39 has a much broader base and size than the other projecting member 38. These inwardly projecting members located on the underside of the trigger lever 16 normally confront the outward projections 35 and 36 on the safety slide, such that when the trigger lever 16 is rotated into its closed or substantially closed position as shown in FIGS. 1 and 2, the interaction of these members provides the three modes of operation.

FIGS. 6, 7, and 8 diagrammatically illustrate the interaction of the reciprocal safety slide with the opposing portions on the underside of the trigger lever 16 to provide the three modes of operation discussed.

FIG. 7 illustrates the interaction of the projections 35 and 36 on the safety slide with projections 38 and 39 on the trigger lever 16 for the "lock" or "safety" position. In this position of the safety slide, its projections 35 and 36 are interfitted in the spaces between and above the projections 38 and 39 on the trigger lever 16, and accordingly the trigger lever 16 is locked and cannot rotate in either direction to either fire the weapon 10 or to open the lever 16 of the weapon 10 for removing the pressurized cartridge. Since the trigger lever 16 is L-shaped and rotates about one end, rotation in either direction requires a slight upward or downward direction of motion which is prevented by the surfaces of projecting members 39 and 38 on the lever 16 striking the confronting surfaces of the projections 35 and 36 on the slide member.

In order to fire the weapon, the safety slide is reciprocated to the right as shown in FIG. 8. In this position, the trigger lever 16 can be rotated downwardly and inwardly by squeezing the trigger 12, since the projections 35 and 36 of the safety slide are displaced to the right and out of interfitting engagement with the projections 38 and 39 on the trigger lever 16. However, in this position, the trigger lever 16 cannot be rotated to an open position, since this involves a slight upward and outward movement of the trigger lever 16 and any such attempted upward movement of the trigger lever causes the upper surface of projections 39 on the lever to strike the base surface of projection 36 on the safety slide. Therefore, as

briefly discussed above, in the "fire" position of the safety lever, the trigger can be squeezed inwardly to fire the weapon, but the trigger lever 16 cannot be rotated upwardly to open the top of the dispenser to remove the cartridge.

In the final position of the safety slide where it is desired to open the trigger lever 16 permitting replacement of the cartridge, yet, it is also desired to prevent accidental firing of the spray, the interaction of the members is shown diagrammatically in FIG. 6. In this mode, the safety slide is moved to the left as viewed in this figure, and the projections 35 and 36 of the safety slide are also positioned out of interfitting relationship with the projections 38 and 39 on the trigger lever 16. However, the lesser projection 37 or stop located alongside lower projection 36 on the safety slide is positioned between the projections 38 and 39 on the trigger lever 16. This projecting member 37 does not extend as far outwardly as do the other projections 35 and 36 on the safety slide and therefore it permits upward and outward movement of the trigger lever 16 as necessary for rotating the lever to its open position shown in FIG. 3. However, it does provide a stop preventing the inward and downward motion of the trigger arm 16 as would be necessary for firing the weapon. Therefore, in this position, the dispenser may be opened to remove and replace the cartridge 21 but cannot be accidentally or otherwise fired during this replacement operation.

For an understanding of the manner of properly operating the safety slide in each of these three positions, reference is again made to FIG. 5. The safety slide additionally includes an integrally formed upper spring arm 42 having a pointed portion which is normally urged by the compression spring to bear against a projecting cam surface 43 attached to the inner wall 13a of the dispenser. In the normal locked "safety" position of the slide shown in FIG. 7, the action of spring 32 and spring arm 42 against the cammed stop 43 centers the safety slide to maintain the trigger lever locked or in safety position as shown in FIG. 7.

When the safety slide is reciprocated to the left, as viewed in FIG. 5, to its "fire" position, the pointed spring arm 42 is deformed forwardly by the cam and rides up the cam surface 43a of the cam 43 in its travel until striking a depression 43b forming a detent. The arm 42 then snaps back into place in the detent 43b. Thereafter the safety slide is held in this "fire" position by the pointed spring arm 42 seating within the detent or depression 43b of the stop member 43. For restoring the slide to "safety," the projecting left-hand end of the slide (15a in FIG. 5) is then depressed to move the safety slide to the right and displace the spring arm 42 out of its detent 43b to its initial position engaging the cam surface 43a. This permits the slide to reciprocate to its centered "locked" or "safety" position.

For opening the dispenser by displacing the slide to its third position, and further to the right, as viewed in FIG. 5, (to the left in FIG. 6), the square end 15a is further depressed to the right against the resistance of compression spring 32. When the projections 35 and 36 on the slide are out of interfitting relationship with projections 38 and 39 on the trigger lever 16, a pair of wire springs 50 and 51 attached to the underside of the face 19 of the trigger lever 16 (FIGS. 2 and 3) push up against the cap 23 of the cartridge 21 and cause the trigger lever 16 to pop open to its position shown in FIG. 2. For again closing the dispenser, the square end 15a of the safety slide is again momentarily pressed against spring 32 (to the right in FIG. 5) permitting the trigger lever 16 to be closed, whereupon the safety slide is released to again lock the trigger lever 16 in its normal closed position of FIG. 7.

For low cost and lightweight construction, all of the parts discussed above with the exception of the pressurized cartridge container 21 are preferably constructed of plastic materials. The body and walls of the dispenser, including both upper and lower portions are preferably molded in two complementing sections that are adapted to fit together as shown and are made of high strength and impact resistant rigid plastic. The L-shaped trigger lever member 16 is also molded

as a one-piece unit of such suitable plastic materials. The safety slide member of FIG. 5 is also preferably molded in one integral piece of a semirigid tough plastic; and the specially formed cap 23 for the standard cartridge 21 is also molded of rigid plastic and having the slotted opening 29 as shown as well as the flange 26 and projection 24 as integral parts thereof.

We claim:

1. In a nonlethal weapon for producing a liquid spray of lacrymating irritant from a pressurized container,
 - a body member for retaining the container and being shaped to be accommodated in only one given orientation within the hand,
 - a trigger member pivotally mounted on the body member to actuate the container to emit a spray and having a finger squeezing portion disposed to be squeezed by the finger when the body member is held in the given orientation,
 - and a selectively adjustable lock and safety means for selectively locking the trigger against movement; for permitting actuation of the trigger to spray; and for permitting removal of the container from the body portion;
 said lock and safety means including a safety member moveably supported on the body and having portions interengageable with the trigger mechanism, said safety member in a first position with respect to the body member preventing pivotal movement of the trigger member in either direction; in a second position permitting combined downward and inward pivotal movement of the trigger mechanism but preventing upward and outward movement thereof; and in a third position permitting upward and outward pivotal movement of the trigger mechanism and preventing downward and inward movement thereof.
2. In a nonlethal weapon for producing a liquid spray of lacrymating irritant from a pressurized container,
 - a body member for retaining the container and being shaped to be accommodated in only one given orientation within the hand,
 - a trigger member pivotally mounted on the body member to actuate the container to emit a spray and having a finger squeezing portion disposed to be squeezed by the finger when the body member is held in the given orientation,
 - and a selectively adjustable lock and safety means for selectively locking the trigger against movement; for permitting actuation of the trigger to spray; and for permitting removal of the container from the body portion;
 said trigger member including a U-shaped member pivotally interconnected with the body member at the rear of the body member to provide a combined inward and downward movement when squeezed toward the body member and a combined upward and outward movement when pivoted away from the body member, said trigger member being provided with a C-shaped projection on its underside facing the body member, and said safety means including a member having a complimentary C-shaped projection facing the underside of the said trigger member and being moveably supported on the body member to variously interengage with positions of said C-shaped projection on the trigger member in different relative positions thereof.
3. In a nonlethal weapon for producing a liquid spray of lacrymating irritant from a pressurized container,
 - a body member for retaining the container and being shaped to be accommodated in only one given orientation within the hand,
 - a trigger member pivotally mounted on the body member to actuate the container to emit a spray and having a finger squeezing portion disposed to be squeezed by the finger when the body member is held in the given orientation,
 - and a selectively adjustable lock and safety means for selectively locking the trigger against movement; for permitting actuation of the trigger to spray; and for permitting removal of the container from the body portion;

said body member comprised of a hollow receptacle for detachably retaining the pressurized container, and said trigger member being disposed with respect to said body to pivot downwardly toward said pressurized container when the trigger is squeezed and upwardly from said pressurized container when the trigger mechanism is pivoted in the opposite direction, and said trigger member being provided with actuating means for operating the container to emit a spray.

4. In the weapon of claim 3, said body member and said trigger member substantially completely enclosing the spray emitting portions of said pressurized container to prevent undesired actuation of the pressure container, and said trigger member being pivotally positionable away from said body member to provide access to said pressurized container for replacement.

5. In the weapon of claim 1, means associated with said pressurized container and said body member for detachably locking said pressurized container and said body portion in only one given orientation.

6. In the weapon of claim 5, said means comprising an enclosing cap over said container, and a latching means provided within said body portion for engaging with said projecting member to detachably lock said container within said body portion.

7. In the dispenser of claim 1, said body member comprising a hollow receptacle having an opening to receive the pressurized container, and said pivotally supported trigger member being oriented to close said opening when pivoted in a closed direction and to expose said opening for access to said container when pivoted in an open direction.

8. In the weapon of claim 7, said trigger member including an inwardly facing projection confronting said pressurized container when said trigger mechanism is pivoted toward said closed position, and means permitting actuation of said pressurized container only by said downwardly projecting means when said trigger member is further squeezed in said closed position.

9. A dispenser for spraying fluids from a pressurized container having a valve and nozzle;

a receptacle having means for retaining the valve and nozzle of said pressurized container in a substantially completely enclosed manner to prevent undesired actuation, said receptacle having a hand gripping portion that is shaped to be accommodated in only one given easy orientation within the hand,

a trigger mechanism pivotally mounted on said receptacle and having a finger engaging portion disposed at a forward position of said receptacle to be actuated by the finger when the receptacle is retained in said given orientation in the hand,

said trigger mechanism comprising a portion of the said enclosure when pivoted in its downward direction and providing an opening in said receptacle for access to said cylinder when pivoted in its upward position,

said trigger mechanism including an inwardly projecting actuating member disposed to actuate the valve mechanism of said enclosed container,

and safety means for selectively locking the trigger

mechanism against any movement; for permitting actuation of the trigger mechanism to operate the valve of said container; and for selectively permitting upward pivoting of said trigger mechanism for access to remove the pressurized container.

10. In a nonlethal weapon for spraying lacrymating irritant from a pressurized container having a valve and nozzle, a dispenser comprising a hollow receptacle for accommodating said container and having an opening to receive and remove the container,

said dispenser including a hand gripping portion shaped for orientation in the hand in one easy direction,

a trigger mechanism pivotally supported on said dispenser and having means for actuating said valve when the trigger is squeezed,

said trigger mechanism pivotally positionable to selectively cover and uncover said opening and being provided with an opening aligned with said nozzle,

means associated with said dispenser for detachably retaining said container in only one orientation with respect to said dispenser with the container nozzle facing forwardly when said hand gripping portion is retained in said easy orientation,

and adjustable safety means supported on said dispenser for selectively locking and unlocking said trigger mechanism for pivotal movement.

11. In the dispenser of claim 10, said trigger mechanism comprising a U-shaped member disposed over the top of said hand gripping portion with one leg of the U-shaped member pivotally supported at the rear side of the hand gripping portion and the other leg thereof disposed over the front side of the hand gripping portion and forming a finger engaging trigger, whereby said finger engaging trigger is constrained to move in a combined downward and inward direction when the trigger is squeezed and constrained to move in an combined upward and outward direction when the trigger is pivoted in the opposite direction.

12. A dispenser comprising the combination of a container and a body member:

the container comprising a receptacle for receiving and storing material to be sprayed, a dispensing valve on said container, a cap for covering the container having a first opening through which said material is dispensed, said cap provided with a second opening to provide access to said valve, a positioning projection on said cap;

the body member having an internal recess for receiving the container and an external surface configuration suitable for manual gripping, means on the body member cooperating with said positioning projection to orient the container in a given direction within the body member, a trigger member pivotally mounted on the body member having a projection adapted to register with said second opening and to engage said dispensing valve whereby the trigger when moved in a given direction about its pivot actuates the valve, and a selectively adjustable lock and safety means on said body member for selectively locking the trigger against movement, for permitting actuating of the trigger to spray, and for permitting removal of the container from the body portion.