

(19)



(11)

EP 1 714 034 B1

(12)

EUROPEAN PATENT SPECIFICATION

(45) Date of publication and mention of the grant of the patent:

31.08.2016 Bulletin 2016/35

(51) Int Cl.:

F04B 49/00^(2006.01) F04B 1/30^(2006.01)

(21) Application number: **05713559.2**

(86) International application number:

PCT/US2005/004723

(22) Date of filing: **11.02.2005**

(87) International publication number:

WO 2005/078284 (25.08.2005 Gazette 2005/34)

(54) **ROTARY HYDRAULIC MACHINE AND CONTROLS**

HYDRAULISCHE ROTATIONSMASCHINE UND STEUERUNGEN

MACHINE HYDRAULIQUE ROTATIVE ET COMMANDES

(84) Designated Contracting States:

AT BE BG CH CY CZ DE DK EE ES FI FR GB GR HU IE IS IT LI LT LU MC NL PL PT RO SE SI SK TR

(72) Inventor: **KADLICKO, George**

Rockford, IL 61107 (US)

(30) Priority: **11.02.2004 US 776768**

11.02.2004 US 776769

11.02.2004 US 776770

11.02.2004 US 776771

11.02.2004 US 776772

(74) Representative: **Karlsson, Leif Gunnar Börje et al**

Ström & Gulliksson AB

P.O. Box 4188

203 13 Malmö (SE)

(43) Date of publication of application:

25.10.2006 Bulletin 2006/43

(56) References cited:

US-A- 3 252 426 US-A- 3 306 209

US-A- 3 834 836 US-A- 3 846 049

US-A- 4 077 746 US-A- 4 097 196

US-A- 4 850 544

(73) Proprietor: **Concentric Rockford, Inc**

Rockford, IL 61104 (US)

EP 1 714 034 B1

Note: Within nine months of the publication of the mention of the grant of the European patent in the European Patent Bulletin, any person may give notice to the European Patent Office of opposition to that patent, in accordance with the Implementing Regulations. Notice of opposition shall not be deemed to have been filed until the opposition fee has been paid. (Art. 99(1) European Patent Convention).

Description

BACKGROUND OF THE INVENTION

FIELD OF THE INVENTION

[0001] The present invention relates to hydraulic machines.

DESCRIPTION OF THE PRIOR ART

[0002] There are many different types of hydraulic machines that can be used to convert mechanical energy into fluid energy and vice versa. Such machines may be used as a pump in which mechanical energy is converted into a flow of fluid or as a motor in which the energy contained in a flow of fluid is converted into mechanical energy. Some of the more sophisticated hydraulic machines are variable capacity machines, particularly those that utilize an inclined plate to convert rotation into an axial displacement of pistons or vice versa.

[0003] Such machines are commonly referred to as swashplate pumps or motors and have the attribute that they can handle fluid under relatively high pressure and over significant range of flows. A particular advantage of such machines is the ability to adjust the capacity of the machine to compensate for different conditions imposed upon it.

[0004] The swashplate machines are, however, relatively complex mechanically with rotating and reciprocating components that must be manufactured to withstand large hydraulic and mechanical forces. These constraints lead to a reduction in the efficiency due to mechanical and hydraulic losses, a reduced control resolution due to the mechanical inefficiencies and the required size and mass of the components and a relatively expensive machine due to the manufacturing complexity.

[0005] In use as a variable capacity machine the swashplate is modulated to achieve a desired movement of component of a machine, either a position, rate of movement or applied force.

[0006] The movement of the swashplate is usually controlled by a valve supplying fluid to an actuator that acts through a compression spring on the swashplate. Control signals for the valve are generated from a set controller and a feedback, typically provided by a sensed parameter. In its simplest form the feedback may be provided by the operator who simply opens and closes the valve to achieve the desired movement or positioning of the component. More sophisticated controls however sense preselected parameters and provide feedback signals to a valve controller. The valve controller may be mechanical, hydraulic but more usually electronic to offer greater versatility in the control functions to be performed.

[0007] The control of the swashplate is determined to a large extent by the response of the system to changes of the sensed parameter. In order for effective response to be obtained, the valve must be able to supply the ac-

tuators controlling the swashplate with fluid under pressure at all times. At the same time, however, the pressure of fluid delivered by or to the machine may vary and accordingly a source of pressure at optimum conditions may not be available. The common technique to provide pressurized fluid is to use a separate charge pump but this is expensive and inefficient.

[0008] US 3 306 209 discloses a multi-fluid pump comprising first, second and third pumps having respective first, second and third rotors, pistons and cam plates, means to collectively control each cam plate, including a pressure responsive member arranged to operate one of said cam plates, a link means to connect said one of said cam plates to each of the other of said cam plates and a spring means operatively connected to said cam plates and a link means to oppose said pressure responsive member. A control valve is arranged to actuate said pressure responsive member and a first passage means in the pump is arranged for delivering separate fluids to each of said pumps with one of said passages adapted to supply a fluid to cool the pump before being circulated by centrifugal force to the pump pistons. A second passage means in said pump is arranged for exhausting fluids from each of the pump means with one of said passages being adapted to intermix a pair of fluids in a constant ratio throughout a control range for said pump. Finally, a bypass means for each of said fluids is operatively connected between said first and second passage means to permit normal circulation of fluid regardless of pump operation.

[0009] The response of the machine is also dependent on the mechanical and hydraulic losses present in the machine during its operation. A mechanically inefficient machine will not respond consistently as loads on the machine vary and the dynamics and static operating characteristics may differ significantly leading to a less predictable response.

[0010] It is therefore an object to the present invention to obviate or mitigate the above disadvantages.

SUMMARY OF THE INVENTION

[0011] In accordance to the present invention, there is provided a rotary hydraulic machine having a housing, and a rotating group located within the housing. The rotating group includes a plurality of variable capacity chambers defined between pistons slideable within respective cylinders. The pistons are displaceable relative to the cylinders upon rotation of the barrel to vary the volume of the chambers and thereby induce a flow of fluid through the chambers from an inlet port to an outlet port as the rotating group rotates. An adjustment assembly includes an actuator operable upon the rotating group to adjust the stroke of the pistons in the cylinder and thereby adjust the capacity of the machine. A fluid supply is provided for the actuator and a control valve is interposed between the fluid supply and the actuator to control flow to the actuator. The fluid supply includes a pressu-

rised fluid source and a hydraulic accumulator to store pressurised fluid from the source. A check valve is located between the accumulator and the source to inhibit flow from the accumulator to the source upon reduction of pressure at said source below that of said accumulator.

[0012] Preferably the control valve is a closed centre valve and is moveable from a centred position in which flow to and from the actuator is inhibited to a first position in which flow to the actuator from the accumulator is permitted and to a second position in which flow from the actuator to a drain is permitted.

BRIEF DESCRIPTION OF THE DRAWINGS

[0013] Embodiments of the invention will now be described by way of example only with reference to the accompanying drawings in which:

Figure 1 is a side elevation of a hydraulic machine. Figure 2 is a top view of the hydraulic machine of Figure 1.

Figure 3 is a view on the line III-III of Figure 2.

Figure 4 is a view on the line IV-IV of Figure 1.

Figure 5 is a perspective view of the rotating components of the machine shown in Figures 3 and 4. Figure 6 is an exploded perspective view of the component shown in Figure 5.

Figure 7 is a front perspective view, partly in section of the assembly shown in Figure 3.

Figure 8 is a perspective view of a portion of the machine in the direction of arrow VIII-VIII of Figure 3.

Figure 9 is an enlarged view of the portion of the machine shown in Figure 4 within the circle A.

Figure 10 is a schematic representation of the assembly of a set of components used in the machine of Figures 4 and 5.

Figure 11 is a view on the line XI-XI of Figure 1.

Figure 12 is a top view on the line XII-XII of Figure 1.

Figure 13 is a view similar to Figure 12 showing alternate positions of the components of the machine shown in Figures 4 and 5.

Figure 14 is a view on the line XIV-XIV of Figure 1.

Figure 15 is a section on line XV-XV of Figure 3.

Figure 16 is a view on the line XVI-XVI of Figure 15.

Figure 17 is a schematic hydraulic circuit showing the operation of the components shown in figure 1 to 16.

Figure 18 is a section through a tool used to assemble the components shown schematically in Figure 10.

Figure 19 is a detailed view of a portion of the tool shown in Figure 18.

Figure 20 is a plan view of a further tool used to assemble the components shown in Figure 10.

Figure 21 is a view similar to Figure 4 of an alternative embodiment of machine.

Figure 22 is a front view of a port plate used in the embodiment of Figure 4.

Figure 23 is a side view of the port plate of Figure 22.

Figure 24 is a rear view of the port plate of Figure 23.

Figure 25 is a section on the line XXV - XXV of Figure 22.

Figure 26 illustrates the sequential movement of a cylinder across a port plate of Figure 22

Figure 27 is an exploded perspective view of a further embodiment of port plate;

Figure 28 is a rear perspective view of the port plate of Figure 27;

Figure 29 is a front view of the port plate of Figure 27; Figure 30 is a section on the line XXX-XXX of Figure 29;

Figure 31 is a section on the line XXXI-XXXI of Figure 29;

Figure 32 is a section on the line XXXII-XXXII of Figure 29;

Figure 33 is an end view of an alternative embodiment of swashplate

DESCRIPTION OF THE PREFERRED EMBODIMENTS

[0014] Referring therefore to Figures 1 through 4, a hydraulic machine 10 includes a housing 12 formed from a casing 14, an end plate 16 and a control housing 18. The casing 14 has an opening 15 on its upper side with a planar sealing surface 17 around the opening 15. The control housing 18 has a lower surface 19 that extends across the opening 15 and is secured to the casing 14. The control housing 18, end plates 16 and casing 14 define an internal cavity 20 in which the rotating group 22 of the machine 10 is located.

[0015] As can be seen in Figures 3, 4, 5 and 6, the rotating group 22 includes a drive shaft 24 that is rotatably supported in the casing 14 on a roller bearing assembly 26 and sealed with a seal assembly 28. One end of the drive shaft 24 projects from the casing and includes a drive coupling in the form of a key 30 for connection to a drive or driven component (not shown) e.g. an engine, electric motor or wheel assembly. The opposite end 32 of the drive shaft 24 is supported in a roller bearing 34 located in a bore 36 of the end plate 16. The shaft 24 is thus free to rotate along a longitudinal axis A-A of the housing 12.

[0016] A barrel 40 is secured to the shaft 24 by a key 42 located in a key way 44 formed in the shaft 24. The barrel 40 similarly has a key way 46 that allows the barrel 40 to slide axially onto the shaft 24 and abut against a shoulder 48 formed on a drive shaft 24. The barrel 40 is provided with a set of axial bores 50 uniformly spaced about the axis of the shaft 24 and extending between oppositely directed end faces 52,54. As can be seen in greater detail in Figure 9, each of the bores 50 is lined with a bronze sleeve 56 to provide a sliding bearing for a piston assembly 58, described in greater detail below.

[0017] A toothed ring 60 is secured on the outer surface of the barrel 40 adjacent the end face 52. The toothed ring 60 has a set of uniformly spaced teeth 62 each with

a square section and is a shrink fit on the barrel 40. The barrel 40 is formed from aluminium and the toothed ring 60 from a magnetic material. The barrel 40 has reduced diameter adjacent to the ring 60 so that the teeth 62 project radially from the surrounding surface of the barrel 40.

[0018] A port plate 64 is located adjacent to the end face 54 and has a series of ports 66 at locations corresponding to the bores 50 in the barrel 40. The port plate 64 is located between the barrel 40 and the end plate 16 and is biased into engagement with the end plate 16 by coil springs 68 and a conical washer 70. The coil springs 68 are positioned at the radially outer portion of the barrel 40 and between adjacent bores 50 to bias the radially outer portion of the plate 64 into engagement with the end plate 16. As seen more clearly in Figure 9, the conical washer 70 is located at the radially inner portion of the barrel 40 and its radially outer edge received in a recess 72 formed in the port plate 64 to urge the inner portion against the end plate 16. The port plate 64 is thus free to float axially relative to the barrel 40.

[0019] To provide fluid transfer between the bores 50 and the ports 66, an annular sleeve 74 is located within each of the bores 50 and sealed by an O-ring 76. The opposite end of the sleeve 74 is received in the circular recess 67 of the port 66, as best seen in Figure 9, and is located axially by a shoulder 68 provided on the sleeve 74. A fluid tight seal is thus provided between the barrel 40 and the port plate 64. The ports 66 smoothly transform from a circular cross-section facing the bore 50 to an arcuate slot for co-operation with conduits 78, 79 formed in the end plate 16.

[0020] As most readily seen in Figure 8, the end plate 16 has a pair of kidney ports 80,82 disposed about the bore 36. The kidney ports 80, 82 connect pressure and suction conduits 78, 79 respectively to fluid entering and leaving the bores 50. The end plate 16 has a circular bearing face 84 that is upstanding from the end plate 16 and has a set of radial grooves 86 formed in a concentric band about the axis of the shaft 24. The grooves 86 provide a hydro-dynamic bearing between the port plate 64 and the bearing face 84 in order to maintain a seal whilst facilitating relative rotation between the port plate 64 and face 84.

[0021] Referring again to Figure 4 and 9, each of the piston assemblies 58 is axially slideable within a respective sleeve 56 and comprises a tubular piston 90 and a slipper 92 interconnected by a ball joint 94. The piston 90 is formed from a tube that is heat treated and ground to diameter to be a smooth sliding fit within the sleeves 56. As can be seen in greater detail in Figure 10, the outer surface of one end 96 of the piston 90 is reduced as indicated at 98 and a part spherical cavity 100 formed on the inner walls of the end 96. The cavity 100 is dimensioned to receive a ball 102 with a through bore 104. The cavity 100 has an axial depth greater than the radius of the ball 102 so that the inner walls extend beyond the equator of the ball 102. The bore 104 in ball 102 is

stepped as indicated at 106 to provide an increased diameter at its inner end.

[0022] During the first step of forming of the piston assembly 58, indicated at 109, the ball 102 is inserted in the cavity 100 with the bore 104 aligned generally with the axis of the piston 90. To retain the ball 102 in the cavity 100, the reduced section 98 of the piston 90 at the end 96 is swaged about the ball 100 indicated in Figure 10 (b).

[0023] Slipper 92 that has a stem 110 and a base 112 is inserted into the bore 104 (step (c)). A passageway 114 is formed through the stem 110 to communicate between the interior of the piston 90 and a recess 116 formed in the base 112. The slipper 92 is secured to the ball 102 by swaging, the end of the stem 110 so it is secured by the step 106, as shown in step (d).

[0024] After securing the slipper to the ball, a radial force is applied to the equator of the ball as indicated by the arrows F in Figure 10e that has the effect of displacing the material on the equator to provide a small clearance between the ball 102 and cavity 100. This clearance enables the ball joint 94 to rotate smoothly within the cavity 100 whilst maintaining an effective seal from the interior of the piston.

[0025] The process shown in Figure 10 may conveniently be performed using the tool set shown in Figures 18, 19 and 20. A tool set 120 has a fixed die 122 and a moveable die 124. The fixed die 122 is secured to a base plate 126 and has a central pin 128 on which the piston 90 is located. A supporting sleeve 130 supports the upper end of the piston 90 adjacent to the reduction 98. The pin 128 also aligns the ball 102 by extending into the bore 104 of the ball 102.

[0026] The moveable die 124 is formed with a part spherical recess 132 dimensioned to engage the end 96 and form it about the ball 102. The moveable die may be advanced into engagement with the ball 102 through the action of a press in which the tool set 120 is mounted.

[0027] After forming, the piston assembly 58 is inserted into a 3 disk die 134 shown in Figure 20. The 3 disk die has a pair of driven rollers 135 and an idler roller 136 that are disposed around the circumference of the end 96 of the piston assembly 58 to form point contact with the outer surface 98. The idler roller 136 is moveable along a radial path by means of a hydraulic cylinder 137 that applies a constant force to the roller 136. The advance of the roller is controlled by a flow control valve 138 until the material surrounding the equator of the ball 102 is sufficiently displaced to provide free movement of the ball within the cavity.

[0028] Referring again to Figures 4, 5 and 6 of the base 112 of the slipper 92 engages a swashplate assembly 140 supported within the housing 14. The swashplate assembly 140 includes a semi cylindrical swashplate 142 having a generally planar front face 144 and an arcuate rear face 146. The planar front face 144 has a recess 148 to receive a lapped plate 150 against which the slippers 92 bear. The slippers 92 are held against the plate

150 by a retainer 152 that has holes 154 through which the piston assemblies 58 project. The holes 154 are dimensioned to engage the outer periphery of the base 112 of the slipper 92 and inhibit axial movement relative to the plate 150. The retainer 152 is located axially by a pair of C-shaped clamps 156 that are secured to the front face 144 of the swashplate 142. The base 112 thus bears against the lapped face of the plate 150 as the barrel is rotated by the drive shaft 24.

[0029] The rear face 146 of the swashplate 142 is supported on a complimentary curved surface 158 of the casing 14 opposite the end plate 16. The rear face 146 is coated with a polymer to reduce friction between the face 146 and surface 158. A suitable polymer coating is a nylon coating formulated from type 11 polyamide resins, such as that available from Rohm & Haas under the trade name CORVEL. A 70 000 series has been found suitable although other grades may be utilized depending on operating circumstances. After deposition on the face 146, the coating is ground to a uniform thickness of approximately 0.040 inches. Alternatively, it has been found satisfactory to harden the face 146 and apply a TEFLON™ coating.

[0030] As seen in Figure 7, a pair of grooves 160, 162 respectively are formed in the rear face 146 and terminate prior to the linear edges of the face 146 to provide a pair of closed cavities. The grooves 160, 162 are generally aligned with the kidney ports 80, 82 formed in the end plate 16 and it will be noted that the width of the groove 160 which is aligned with the pressure conduit is greater than the width of the groove 162 aligned with the suction conduit. Fluid is supplied to the grooves 160, 162 through internal passageways 164, 166 respectively formed in the casing 14. Flow through the passageways is controlled by a pair of pressure compensated flow control valves 168 that supply a constant flow of fluid to the grooves 160, 162. The grooves 160, 162 thus provide a fluid bearing for the rear face 146 against the surface 158 to facilitate rotational movement of the swashplate 142.

[0031] Adjustment of the swashplate 142 about its axis of rotation is controlled by a pair of actuators 170, 172 respectively located in the casing 14. As shown most clearly in Figures 5 and 11, each of the actuators 170, 172 includes a cylinder 174 in which a piston 176 slides. Each of the cylinders 174 is received within a bore 178 formed in the casing 14 and extending from the end plate 16 into the cavity 20. The cylinders 174 have an external thread 180 which engages with an internal thread on the bore 178 to secure the cylinder in the casing 14. The end plate 16 (Figure 8) has a pair of recesses 192 that fit over the end of the pistons 176. The self contained actuator, 170, 172 located in the casing 14 ensures that axial load generated by the actuators 170 are imposed on the casing 14 rather than across the joint between the end plate 16 and casing 14 to maintain integrity of the housing 12. To avoid distortion of the cylinders 174 during assembly, it has been found preferable to form the cylinder 174 as two components, namely a body 174a which is located

in the bore 178 by a shoulder and an end cap 174b carrying the threads 180. The cap 174b bears against the end of the body 174a to hold it in the bore 178.

[0032] The cylinder 174 is provided with cross drillings 182 to permit fluid supplied through internal passageways 183 (Fig. 12) in the housing 14 to flow to and from the interior of the cylinder 174. A spring 184 acts between the cylinder 174 and piston 176 to bias it outwardly into engagement with the swashplate assembly 140. Preferably one of the springs 184 has a greater axial force than the other so that the swashplate is biased to a maximum strike position in the absence of fluid in the actuators 170, 172.

[0033] The actuators 170, 172 bear against a horse-shoe extension 186 of the swashplate 142 that projects outwardly above the barrel 40. The extension 186 has a pair of part cylindrical cavities 188 at opposite ends into which a cylindrical pin 190 is located. The cavities 188 are positioned such that the outer surface of the pin 190 is tangential to a line passing through the axis of rotation of the swashplate. The end face of piston 176 engages the outer surface of the pin 190 to control the position of the swashplate.

[0034] As illustrated in Figure 13, extension of the piston 176 of one of the actuators 170, 172 will induce rotation of the swashplate assembly 140 in the casing 14 and cause a corresponding retraction of the other of the actuators 170, 172. The assembly 140 slides over the curved surface 158 and as the assembly 140 rotates, the pins 190 maintain contact with the end face of the pistons 176. The position of the pins 190 on a common diameter of the swashplate assembly ensures that a rolling motion, rather than sliding, is provided across the end face of the pistons 176 to reduce friction during the adjustment. As can be seen in Figure 13, the actuators 170, 172 are disposed to provide a full range of rotation on both sides of a neutral or no stroke position with rolling contact being made over this range of motion.

[0035] Flow to the actuators 170, 172 is controlled by a control valve 200, Figure 14, located in the control housing 18. The control valve 200 is a solenoid operated, spool valve having a centred position in which no flow is permitted through the valve. The spool may be moved to either side of the centred position to apply pressure to one of the actuators and connect the other actuator to drain. The control housing 18 is shown in greater detail in Figures 3, 15 and 16 has a peripheral skirt 191 extending from a base 192. A pair of bores 193, 194 extend through the base 192 to receive control valve 200 and an accumulator 220 respectively. Fluid is supplied to the bores 193, 194 by an internal supply gallery 195 and a drain gallery 196 is connected between the bore 193 and the cavity 20 of the casing 12. Internal galleries 197, 198 also communicate between the bore 193 and the internal passageways 183 connected to actuators 170, 172. The valve 200 controls the flow from the internal supply gallery 196 to the actuators and drain as will be described below.

[0036] The fluid flow controlled by the control valve 200

is obtained from the pressure conduit 78 and supplied through an accumulator 220 located in the bore 194 of control housing 18 adjacent to the control valve 200. The accumulator, shown in Figure 14, includes a piston 222 slideable within a cylinder 224 and biased by a spring 226 to a minimum volume. The piston 222 has a seal 223 and carries a stop 228 that limits displacement of the piston 222 within the cylinder 224. The piston 222 may be formed in two pieces to facilitate insertion of the seal 223. The stop 228 in combination with the spring 226 effectively establishes a maximum stored pressure for the accumulator 220. The supply gallery 195 extends through a branch conduit 227 to the interior of cylinder 224 and is connected with the pressure conduit 78 through a check valve 230 located in an internal bore 232 in the housing 14. The check valve 230 ensures that the pressure fluid in the accumulator 220 is maintained as the pressure supplied to conduit 78 fluctuates and that control fluid is available to the valve 200. The supply gallery 195 is also connected to the pressure compensated flow control valves 168 to ensure a constant flow of fluid to the bearings 160, 162.

[0037] To provide control signals to the valve 200, a block 202 is secured to the swashplate 142 within the horseshoe extension 186 and presents a planar surface 204. A position sensor 206 engages the planar surface 204 eccentrically to the axis of rotation of the swashplate assembly 140 to provide a signal indicative of the disposition of the swashplate assembly 140. The position sensor 206 includes a pin 208 slideable within a sensing block 210 that extends downwardly from the control housing 18. The pin 208 is formed from a stainless steel so as to be non-magnetic and has a magnet 212 inserted at its inner end. The sensing block 210 accommodates a Hall effect sensor 214 in a vertical bore 215 where it is sealed to prevent migration of oil from the cavity 20 to the control housing 18. The sensor 214 provides a varying signal as the pin 208 moves axially within the block 210. The Hall effect sensor thus provides a position signal that varies as the swashplate is rotated by the actuators 170, 172.

[0038] The sensing block 210 also carries a further Hall effect sensor 216 located in a bore 217 extending through the block 210 to a nose 219 positioned adjacent to the toothed ring 60. The sensor 216 is sealed in the bore 217 and provides a fluctuating signal as the teeth 62 pass it so that the frequency of the signal is an indication of rotational speed of the barrel 22. The control signals obtained from the Hall effect sensors 214 and 216 are supplied to a control circuit board 218 located within the control housing 18. Further input signals, such as a set signal from a manual control, a temperature signal indicating the temperature of fluid in the machine, and a pressure signal indicating the pressure of fluid in the pressure conduit 78, are obtained from transducers located in or adjacent to the conduits 78, 80. The input signals are also fed to the control circuit board 218 which implements a control algorithm using one or more of the set, pressure,

temperature and flow signals fed to it. The output from the control circuit board 216 is provided to the control valve 200 which is operable to control the flow to or from the actuators 171, 172 in response to the control signal received.

[0039] The operation of the machine 10 will now be described. For the purpose of the description it will be assumed that the machine is functioning as a pump with the shaft 24 driven by a prime mover such as an electric motor or internal combustion engine. Initially, the bias of the springs has moved the swashplate 140 to a position of maximum stroke and fluid in the accumulator 220 has discharged through the flow control valves 168. Rotation of the shaft 24 and barrel 40 causes full stroke reciprocation of the pistons 58 as the slippers 92 move across the lapped plate 150 to discharge fluid into the pressure port 78. The fluid is delivered through the check valve 230 to the supply gallery 195 to provide fluid to the control valve 200 and charge the accumulator 220.

[0040] In its initial condition, the control is set to move, the washplate assembly 140 to a neutral or no-flow position. Accordingly, as fluid is supplied to the control valve 200, it is directed to the actuator 170 to move the swashplate 140 to the neutral position. As the swashplate moves toward the neutral position, the pin 208 of position sensor 206 follows the movement and adjusts the position signal provided to the board 218. Upon attainment of the neutral position, the flow to the actuator 170 is terminated by the valve 200. In this position, the barrel 22 is rotating but the piston assembly 58 is not reciprocating within the barrel. The accumulator 220 is charged to maintain supply to the flow control valves 168 through the gallery 195, and to the control valve 200.

[0041] After initialization, the circuit board 218 receives a signal indicating a movement of the swashplate assembly 140 to a position in which fluid is supplied to the pressure port 78. The signal may be generated from the set signal, such as a manual operator, or from a pressure sensing signal and results in a control signal supplied to the valve 200. The valve 200 is moved to a position in which it supplies fluid to the actuator 170 and allows fluid from the actuator 172 to flow to a sump. The supply fluid to the actuator 170 causes the piston 176 to extend and bear against the pin 190. The internal pressure applied to the piston 176 causes rotation of the swashplate assembly 140 with the surface 146 sliding across the surface 158. Until such time as pressure is delivered to the pressure port 78, the pressurized fluid is supplied from the accumulator 220 through the control valve and into the interior of the actuator 170 to induce the rotation. As the swashplate assembly is rotated about its axis, the slippers 92 are retained against the lapped plate 150 and the stroke of the pistons 90 is increased. Fluid is thus drawn through the suction port 69 past the kidney port 82 and into the pistons as they move outwardly from the barrel. Continued rotation moves the pistons into alignment with the pressure port 78 and expels fluid from the cylinders as the pistons 90 move into barrel. The pressure

supplied to the port 78 is also delivered to the internal supply galleries 195 to replenish the accumulator 220.

[0042] As the swashplate rotates, the pin 208 follows the movement of the planar surface 204 and provides a feedback signal indicative of the capacity of the barrel assembly 22. The signal from the toothed ring 60 also provides a feedback signal indicative of rotation so that the combination of the signal from the pin 208 and the signal from the ring 60 may be used to compute the flow rate from the pump. If the set signal is a flow control signal then the combination of the speed and position are used to offset the set signal and return the valve 200 to a neutral position once the required flow is attained. Similarly, if the set signal indicates a pressure signal, then the pressure in the port 78 is monitored and the valve returned to neutral upon the set pressure being obtained.

[0043] As the swashplate 142 is adjusted, the flow of fluid into the grooves 160, 162 on the rear face 146 of the swashplate is controlled by the flow of the control valves 168 so that a constant support for the swashplate is maintained. Similarly, the port plate 64 is maintained against the end face by the action of the spring 68, 70 to maintain a fluid tight seal for the passage of fluid into and out of the barrel assembly 40.

[0044] Movement of the swashplate to a position in which pressurized fluid is delivered to the port 78 recharges the accumulator 220 as well as supplying flow to the actuators 170 and 172 and the grooves 160, 162. If the swashplate assembly 140 is returned to a neutral position, the pressurized fluid in the accumulator 220 is sufficient to provide the control function and maintain the balance of the swashplate 142.

[0045] During adjustment of the swashplate 142, the rolling action of the pins 190 across the end faces of the pistons 176 further minimizes the frictional forces applied to the swashplate 140 and thereby reduces the control forces that must be applied.

[0046] It will also be appreciated that by providing the ball joint 94 as part of the slipper, the forces imposed on the slipper are minimized and the angle of adjustment available increased to enhance the range of follow rates that are available.

[0047] All movement of the swashplate 140 is followed by the pin 208 and variations in the rotational speed are sensed by the pickup 216 to permit the control board 218 to provide adjustment of the control parameters. It will also be noted that the control function is located in the housing 18 separate from the rotating component so that the control board 218 and associated electric circuit is not subject to the hydraulic fluid that might adversely affect their operation.

[0048] The provision of the key 42 on the shaft 24 inhibits relative rotation between the shaft and barrel and thus reduces the oscillation and fretting that otherwise occurs with a typical splined connection. Any misalignment between the barrel and port plate 64 is accommodated by the spring biasing applied to the port plate 64 by the springs 68, 70 so that the keyed connection to the

shaft is possible.

[0049] The accumulator provides a supply of pressure fluid to the control valve 200 to enhance the response to variations in the control signal when the pressure in the discharge system falls below the accumulator setting.

[0050] If the machine 10 is to be utilized as a motor, it will be appreciated that the pin 208 is operable to follow movement of the swashplate to either side of a neutral condition and therefore provide reversibility of the output shaft 24 that is used to drive a load. During such operation, the line 78 will be at a low pressure but the accumulator 220 supplies fluid to the control valve 200 to maintain control of the swashplate.

[0051] In the above embodiment, the port plate is biased against the end plate and floats relative to the barrel 40. An alternative embodiment is shown in Figures 21 to 26 in which like components are denoted with like reference numerals with a suffix 'a' added for clarity.

[0052] In the arrangement shown in Figures 21 to 26, the port plate 64a is arranged to float relative to the end plate 16a and for relative rotation to occur between the barrel 40a and the port plate 64a. The port plate 64a is biased into sealing engagement with the barrel 40a by springs 68a received in a counterbore 68a. In this way, minor misalignment between the barrel and end plate is accommodated. The counterbore 68a is sealed to the end plate 16a by sleeves 74a that accommodate axial movement and maintain a seal with O-rings 76a.

[0053] As can be seen from Figure 22, the port plate 64a has a pair of kidney shaped ports 300, 302. The port 300 extends through the plate 64a with a central web 304 recessed from the front face 306 of the plate 64a. The rear face 308 as shown in Figure 24, is undercut as indicated at 310 to provide a clearance between the plate 64a and the end wall 16a.

[0054] The port 302 extends partially through the plate 64a and is intersected by three pressure ports 312 that extend from the rear face 308. Each of the ports 312 is configured to receive a sleeve 74a which engages in complimentary recesses in the end face 16a to provide a sealed communication between the plate 64a and the end face 16a.

[0055] A restricted orifice 314 is formed at the inner end of the counterbore 68a so as to extend through to the front face 306. The orifice provides a restricted access to the chamber formed by the sleeve 74a within the counterbore 68a and is positioned between the kidney ports 300, 302. A V-shaped notch 316 is formed in the front face 306 and progressively increases in breadth and depth toward the leading edge of the kidney port 302.

[0056] In operation, the front face 306 of plate 64a is forced against the end face of the barrel 40a. The bores 50a are located at the same radius as the kidney ports 300, 302 and therefore pass successively over the port plate as the barrel 40 rotates. As the bores 50a traverse the port 300 fluid is induced into the cylinders. Similarly, as the bores 50a traverse the port 302, fluid is expelled from the cylinders and directed through the sleeves 74a

to the pressure conduit 78a. During this rotation, the face 306 is maintained by the springs 68a against the barrel 40a to maintain an effective seal.

[0057] It will be noted that the adjacent ends of the ports 300, 302 are spaced apart by a distance greater than the diameter of the bores 50a. This is shown in Figure 26A where the disposition of the bores at a particular position of the barrel 40a is shown. The bore 50a shown in chain dot line is associated with a piston that has just passed bottom-dead center, ie. the maximum volume of the cylinder and is starting to move axially to expel fluid. However, the rate of movement of the piston is relatively small by virtue of the sinusoidal nature of the induced movement. In the position shown in Figure 26A, the cylinder has just passed the terminal portion of the inlet port 300 but the small land created between the end of the bore and the terminal edge of the port 302 is such that there is a small leakage from the piston into the low pressure port 300. It will also be observed from Figure 26A that the orifice 314 is positioned within the cylinder.

[0058] As the barrel continues to rotate as shown in Figure 26B, the bore is centered over the orifice 314 and the limited movement of the piston is accommodated by compression of the fluid and components within the chamber 68a. Again, because of the sinusoidal nature of the motion, the axial displacement is minimized during this portion of the rotation. Further rotation of the barrel 40a brings the bore 50a to a position shown in Figure 26C in which it overlaps the notch 316 and therefore fluid in the cylinder may be expelled into the high pressure kidney port 302. The tapered dimensions of the notch 316 allows the oil to progressively enter the port 302 to avoid an abrupt transition and thereby reduce potential noise. At this time the cylinder is still in communication with the bore 68a and high pressure fluid within that bore can be expelled through the orifice 314 and into the pressure port 302.

[0059] Continued rotation, as shown in Figure 26D moves the bore 50a so it begins to overlap the kidney part 302 and has unrestricted access to the pressure conduit 78a.

[0060] Similarly, as the bore 50a moves from the inlet port 300 to the pressure port 302, a circumferentially spaced bore indicated at 50a' on Figure 26A moves from the high pressure kidney port 302 to the suction port. As can be seen from Figure 26A, as the piston approaches top-dead center, the communication with the high pressure port is progressively reduced until, as it moves to the position shown in Figure 26C, it is in communication with the orifice 314. Again, the piston is at its minimum rate of axial movement as it passes the top-dead center and the continued displacement of fluid can be accommodated within the chamber 68a. At the position shown in Figure 26D, the piston has gone past top-dead center and is being moved towards bottom-dead center. In this position however, it is not in communication with the low pressure kidney port 300 and the residual pressure within the chamber 68a replenishes the fluid within the cylinder

to avoid cavitation. As the barrel continues to rotate, the cylinder is put into communication with the low pressure port and the fluid is drawn into the cylinder.

[0061] It will be seen therefore that as the barrel 40a rotates, the pistons are alternatively connected to pressure and suction ports 302, 300 and that the spacing of the ports is such as to inhibit leakage between the high pressure and low pressure chambers. The provision of the restricted orifice 314 together with the balancing chamber 68a accommodates the small change in volume as the pistons go over bottom-dead center or top-dead center as well as providing a balancing force to maintain the port plate against the end of the barrel 40a. The undercut 310 provides a relatively unrestricted ingress of fluid into the cylinders to enhance the efficiency of the machine and inhibit cavitation.

[0062] A further embodiment of port plate similar to that shown in Figures 21 to 26 is illustrated in Figures 27 through 32 in which like reference numerals will be utilised to identify like components with a suffix b added for clarity.

[0063] In the arrangement of Figures 27 through 32, the port plate 64b is arranged to float relative to the end plate 16b and for relative rotation to occur between the barrel 40b and the port plate 64b as described above with respect to Figures 21 to 26. The port plate 64b has a pair of kidney shaped ports 300b, 302b. The port 300b extends through the plate 64b with a central web 304b recessed from the front face 306b of the plate 64b. A hydro dynamic bearing 320 is formed on the periphery of the front face 306b to mate with the end face of the barrel 40b. The port 302b extends partially through the plate 64b from the front face 306b and is intersected by pressure ports 312b that extend from a rear face 308b best seen in Figure 28.

[0064] The rear face 308b has a pair of upstanding walls 322, 324 that extend around the periphery of the ports 300b, 302b respectively. A groove 326, 328 is provided in each of the walls 322, 324 to receive respective sealing rings 330, 332. A radial shoulder 334 is formed at the rear face 308b and is a snug fit within a bore 336 provided in the front face of the end plate 16b. A circlip 338 co-operates with a groove formed in the bore 336 to retain the port plate 64a within the bore 336.

[0065] Kidney shape inlet and outlet ducts 340, 342 respectively are provided at the base of the bore 336 and are of complimentary shape to the walls 322, 324 respectively to permit the walls 340, 342 to rest within the ducts. The ducts 340, 342 communicate with the inlet conduit and outlet conduit (not shown) to supply fluid to the rotating group and convey fluid away from the rotating group as is conventional. The sealing rings 330, 332 ensure a fluid tight fit between the walls 322, 324 and their respective ducts 340, 342 whilst accommodating limited axial movement.

[0066] The port plate 64b is biased away from the end plate 16b by springs 68b. The springs 68b are accommodated within the ducts 340, 342 and act against the

end face 308 to provide the necessary bias against the force generated by the pressure of fluid in the barrel. A balancing chamber is formed at diametrically opposed locations on the plate 64b by sleeve 74b. As best seen in Figure 31, the sleeves 74b are accommodated within counter bores 344 in the plate 64b. A restricted orifice 314b connects the counter bore 344 with the front face 306b. The sleeve 74b are axially moveable within the counter bores 344 and are sealed by o-rings on the periphery of the sleeve 74b. The balancing chamber are located at the cross over between the pressure and suction ports to accommodate the transition.

[0067] The operation is similar to that described above with respect to Figures 21 through 26. To maintain an effective seal between the port plate 64b and barrel, the area of the recesses 342 is selected to have a slightly greater effective area than the port 302b, typically in the range of 2 to 5% greater, with 3% preferred. A positive bias from the pressurized fluid is thus provided to supplement the action of the spring 68b and maintain a seal between the port plate and the barrel. It is found that if the machine is maintained under pressure but with no rotation, there is a tendency for the pressure fluid to creep between the port plate and barrel and separate the sealing surfaces. The provision of the enlarged area for the port provides a positive bias even without rotation of the barrel relative to the port plate to maintain the ceiling effect. If a perfect seal is assumed between the face of the barrel and the port plate, a differential in area of 25% is found to be suitable. In practice, such an area differential when combined with the inevitable pressure gradient at the edge of the port produces an effective differential in the order of 3% to maintain effective sealing.

[0068] An alternative embodiment of swashplate is shown in Figure 33 in which like components will be denoted with like reference numerals and a suffix 'a' added for clarity. In the embodiment described in Figure 7 above, the grooves 160, 162 are aligned with the kidney ports 80, 82 so as to provide increased load carrying capacity for the high pressure loading of the pistons.

[0069] In the embodiment of Figure 33, the grooves 160a, 162a extend in a direction to bridge the kidney ports 80, 82 and have a varying area to accommodate the loads imposed. As can be seen in Figure 27, each of the grooves 160a, 162a is generally an inverted L-shape with an enlarged head 350 and an elongate tail 352. Flow to the grooves 160a, 162a is controlled by respective flow control valves 168a. A land 352 is provided in the head 350 to adjust the bearing area.

[0070] The head 350 is generally aligned with the line of action of the actuators 170, 172 to provide an enlarged bearing area whilst the tails 352 provide a bearing area for balance of the forces. In this manner, the grooves 160a, 162a are located to provide a fluid bearing in which the higher forces are distributed between the two grooves and the shape of the groove used to compensate for difference loading. It will be noted that the tail 352 is of varying width to provide an increased area in opposition

to the high pressure loads with a reduced area to oppose the low pressure loads. It will be appreciated that the grooves 160a, 162a may be contoured to suit the loading characteristics of the particular machine and provide uniform support for the swashplate.

Claims

1. A rotary hydraulic machine (10) having a housing (12), a rotating group (22) located within said housing (12) and including a plurality of variable capacity chambers defined between pistons (58) slideable within respective cylinders (50) provided in a barrel (40), said pistons (58) being displaceable relative to said cylinders (50) upon rotation of said barrel (40) to vary the volume of said chambers and thereby induce a flow of fluid through said chambers from an inlet port to an outlet port (80, 82) as said rotating group (22) rotates, an adjustment assembly (142) including an actuator (170,172) operating upon said rotating group (22) to adjust the stroke of said pistons (58) in said cylinder (50) and thereby adjust the capacity of said machine (10), a fluid supply for said actuator (170,172) and a control valve (200) interposed between said fluid supply and said actuator (170,172) to control flow to said actuator (170,172), **characterized in that** said fluid supply including a pressurized fluid source derived from one of said ports (80,82), a hydraulic accumulator (220) to store pressurized fluid from said source and apply stored fluid to said control valve (200) and a check valve (230) between said accumulator (220) and said source to inhibit flow from said accumulator (220) to said source upon reduction of pressure at said source below that of said accumulator (220) whilst maintaining the application of stored fluid to said control valve (200).
2. A rotary hydraulic machine according to claim 1 wherein said control valve (200) is a closed centre valve and is moveable from a centred position in which flow to and from said actuator (170,172) is inhibited to a first position in which flow to said actuator (170,172) from said accumulator (220) is permitted and to a second position in which flow from said actuator (170,172) to a drain (196) is permitted.
3. A rotary hydraulic machine according to claim 2 wherein a pair of actuators (170,172) are utilized in said adjustment assembly (142) and when said valve (200) is in said first position, one of said actuators (170,172) is connected through said valve (200) to said accumulator (220) and the other of said actuators (170,172) is connected to drain (196), and, when said valve (200) is in said second position, said one of said actuators (170,172) is connected to drain (196) and said other of said actuators (170,172) is

connected through said valve (200) to said accumulator (220).

4. A rotary hydraulic machine according to claim 3 in which each of said actuators (170,172) is single acting. 5
5. A rotary hydraulic machine according to claim 4 wherein each of said actuators (170,172) is a linear actuator having a piston (176) displaceable within a cylinder (174). 10
6. A rotary hydraulic machine according to claim 5 wherein each of said actuators (170,172) includes a spring (184) to bias said actuator (170,172) to a maximum capacity. 15
7. A rotary hydraulic machine according to claim 6 wherein said one of said springs (184) has a greater bias than the other to move said adjustment assembly (142) to a position of maximum capacity in the absence of pressurized fluid in said accumulator (220). 20
8. A rotary hydraulic machine according to any one of claims 1-6 wherein said accumulator (220) includes a piston (222) displaceable within a cylinder (224) by application of fluid pressure against a spring bias (226). 25
9. A rotary hydraulic machine according to claim 8 wherein a stop (228) is provided to limit displacement of said piston (222) and thereby limit the force applied by said spring (226). 30
10. A rotary hydraulic machine according to claim 9 wherein said spring (226) is a mechanical spring located within said cylinder (224). 35
11. A rotary hydraulic machine according to claim 10 wherein said spring (226) is a coil spring and said stop (228) is located within said cylinder (224) and extends through said coil spring (226). 40
12. A rotary hydraulic machine according to any one of claims 1-6 wherein said valve (200) and said accumulator (230) are each located in respective bores (193,194) in said housing (12) and are interconnected by an internal gallery (195). 45
13. A rotary hydraulic machine according to claim 12 wherein said one of said ports (78,79) is connected by an internal bore (232) to said accumulator (220) and said check valve (230) is located in said internal bore (232). 50
14. A rotary hydraulic machine according to claim 13 wherein said internal bore (232) is connected to said

internal gallery (195) to provide fluid to both said accumulator (220) and said valve (200).

15. A rotary hydraulic machine according to any one of claims 1 - 14 wherein said valve (200) is a closed centre valve to inhibit flow of fluid through said valve (200) in the absence of a control signal to adjust said stroke of said actuators (170,172). 55

Patentansprüche

1. Hydraulische Rotationsmaschine (10) mit einem Gehäuse (12), einer Drehgruppe (22), die innerhalb des Gehäuses (12) angeordnet ist und eine Mehrzahl von Kammern mit variabler Kapazität aufweist, die zwischen Kolben (58) definiert sind, die zwischen zugehörigen Zylindern (50) innerhalb einer Trommel (40) vorgesehen sind, wobei die Kolben (58) in Bezug auf die Zylinder (50) bei Drehung der Trommel (40) verschiebbar sind, um das Volumen der Kammern zu verändern und um dadurch einen Fluss von Fluid durch die Kammern von einem Einlassanschluss zu einem Auslassanschluss (80, 82) zu bewirken, wenn sich die Drehgruppe (22) dreht, mit einer Einstellanordnung (142), die einen Aktuator (170, 172) umfasst, der auf die Drehgruppe (22) wirkt, um den Hub der Kolben (58) in dem Zylinder (50) einzustellen und um dadurch die Kapazität der Maschine (10) einzustellen, mit einer Fluidversorgung für den Aktuator (170, 172) und einem Steuerventil (200), das zwischen der Fluidversorgung und dem Aktuator (170, 172) angeordnet ist, um den Fluss zu dem Aktuator (170, 172) zu steuern, **dadurch gekennzeichnet, dass** die Fluidversorgung eine unter Druck stehende Fluidquelle aufweist, die von einem der Anschlüsse (80, 82) abgeleitet ist, einen Hydraulikkumulator (220), um unter Druck stehendes Fluid von der Quelle zu speichern und um gespeichertes Fluid an das Steuerventil (200) zu liefern, und mit einem Rückschlagventil (230) zwischen dem Akkumulator (220) und der Quelle, um einen Fluss von dem Akkumulator (220) zu der Quelle bei Reduktion des Druckes an der Quelle unter denjenigen des Akkumulators (220) zu verhindern, während die Zufuhr von gespeichertem Fluid zu dem Steuerventil (200) aufrechterhalten wird. 35
2. Hydraulische Rotationsmaschine nach Anspruch 1, bei der das Steuerventil (200) ein geschlossenes Zentralventil ist, das von einer zentrierten Position bewegbar ist, in der ein Fluss zu und von dem Aktuator (170, 172) in einer ersten Position verhindert ist, in der ein Fluss von dem Aktuator (170, 172) von dem Akkumulator (220) erlaubt ist, und in eine zweite Position, in der ein Fluss von dem Aktuator (170, 172) zu einem Abfluss (196) erlaubt ist. 50

3. Hydraulische Rotationsmaschine nach Anspruch 2, bei der ein Paar von Aktuatoren (170, 172) in der Einstellanordnung (142) verwendet werden, und dann, wenn das Ventil (200) in der ersten Position ist, einer der Aktuatoren (170, 172) über das Ventil (200) mit dem Akkumulator (220) verbunden ist, und der andere der Aktuatoren (170, 172) mit dem Abfluss (196) verbunden ist, und dann, wenn das Ventil (200) in der zweiten Position ist, der eine der Aktuatoren (170, 172) mit dem Abfluss (196) verbunden ist und der andere der Aktuatoren (170, 172) über das Ventil (200) mit dem Akkumulator (220) verbunden ist. 5
4. Hydraulische Rotationsmaschine nach Anspruch 3, bei der jeder der Aktuatoren (170, 172) einzeln arbeitet. 10
5. Hydraulische Rotationsmaschine nach Anspruch 4, bei der jeder der Aktuatoren (170, 172) ein linearer Aktuator mit einem Kolben (176) ist, der innerhalb eines Zylinders (174) verschiebbar ist. 15
6. Hydraulische Rotationsmaschine nach Anspruch 5, bei der jeder der Aktuatoren (170, 172) eine Feder (184) aufweist, um den Aktuator (170, 172) für eine maximale Kapazität vorzuspannen. 20
7. Hydraulische Rotationsmaschine nach Anspruch 6, bei der eine der Federn (184) eine größere Vorspannung als die andere aufweist, um die Einstellanordnung (142) in eine Position von maximaler Kapazität einzustellen, wenn kein unter Druck stehendes Fluid in dem Akkumulator (220) ist. 25
8. Hydraulische Rotationsmaschine nach irgendeinem der Ansprüche 1 bis 6, bei der der Akkumulator (220) einen Kolben (222) aufweist, der innerhalb eines Zylinders (224) durch die Anwendung von Fluiddruck gegen eine Vorspannung einer Feder (226) verschiebbar ist. 30
9. Hydraulische Rotationsmaschine nach Anspruch 8, bei der ein Anschlag (228) vorgesehen ist, um die Verschiebung des Kolbens (222) zu begrenzen und um dadurch die von der Feder (226) ausgeübte Kraft zu begrenzen. 35
10. Hydraulische Rotationsmaschine nach Anspruch 9, bei der die Feder (226) eine mechanische Feder ist, die innerhalb des Zylinders (224) angeordnet ist. 40
11. Hydraulische Rotationsmaschine nach Anspruch 10, bei der die Feder (226) eine Schraubenfeder ist und der Anschlag (228) innerhalb des Zylinders (224) angeordnet ist und sich durch die Schraubenfeder (226) erstreckt. 45

12. Hydraulische Rotationsmaschine nach irgendeinem der Ansprüche 1 bis 6, bei der das Ventil (200) und der Akkumulator (230) in betreffenden Bohrungen (123, 124) in dem Gehäuse (12) angeordnet sind und über einen inneren Kanal (195) verbunden sind. 5
13. Hydraulische Rotationsmaschine nach Anspruch 12, bei der einer der Anschlüsse (78, 79) durch eine inneren Bohrung (232) mit dem Akkumulator (220) verbunden ist und das Rückschlagventil (230) innerhalb der inneren Bohrung (232) angeordnet ist. 10
14. Hydraulische Rotationsmaschine nach Anspruch 13, bei der die innere Bohrung (232) mit dem inneren Kanal (195) verbunden ist, um Fluid sowohl zu dem Akkumulator (220) als auch zu dem Ventil (200) zu liefern. 15
15. Hydraulische Rotationsmaschine nach irgendeinem der Ansprüche 1 bis 14, bei der das Ventil (200) ein geschlossenes Zentralventil ist, um einen Fluss von Fluid durch das Ventil (200) in Abwesenheit eines Kontrollsignals zur Einstellung des Hubes der Aktuatoren (170, 172) zu verhindern. 20

Revendications

1. Machine hydraulique rotative (10) ayant un boîtier (12), un groupe rotatif (22) situé dans ledit boîtier (12) et incluant une pluralité de chambres à capacité variable définies entre des pistons (58) pouvant coulisser dans des cylindres respectifs (50) disposés dans un corps (40), lesdits pistons (58) pouvant être déplacés par rapport auxdits cylindres (50) lors de la rotation dudit corps (40) afin de faire varier le volume desdites chambres et d'induire ainsi un écoulement de fluide à travers lesdites chambres depuis un orifice d'entrée vers un orifice de sortie (80, 82) quand ledit groupe rotatif (22) tourne, un ensemble d'ajustement (142) incluant un actionneur (170, 172) agissant sur ledit groupe rotatif (22) afin d'ajuster la course desdits pistons (58) dans ledit cylindre (50) et d'ajuster de ce fait la capacité de ladite machine (10), une alimentation en fluide pour ledit actionneur (170, 172) et une clapet de commande (200) interposé entre ladite alimentation en fluide et ledit actionneur (170, 172) pour commander l'écoulement vers ledit actionneur (170, 172), **caractérisée en ce que** ladite alimentation en fluide inclut une source de fluide sous pression dérivée de l'un desdits orifices (80, 82), un accumulateur hydraulique (220) pour stocker le fluide sous pression provenant de ladite source et appliquer le fluide stocké audit clapet de commande (200) et un clapet de retenue (230) entre ledit accumulateur (220) et ladite source afin d'empêcher l'écoulement depuis ledit accumulateur (220) vers ladite source lors d'une réduction de pres- 50

- sion au niveau de ladite source sous celle dudit accumulateur (220) tout en maintenant l'application de fluide stocké audit clapet de commande (200).
2. Machine hydraulique rotative selon la revendication 1 dans laquelle ledit clapet de commande (200) est un clapet à centre fermé et est mobile depuis une position centrée, dans laquelle l'écoulement vers et depuis ledit actionneur (170, 172) est empêché, vers une première position, dans laquelle l'écoulement vers ledit actionneur (170, 172) depuis ledit accumulateur (220) est permis et vers une deuxième position, dans laquelle l'écoulement depuis ledit actionneur (170, 172) vers un drain (196) est permis.
 3. Machine hydraulique rotative selon la revendication 2 dans laquelle une paire d'actionneurs (170, 172) sont utilisés dans ledit ensemble d'ajustement (142) et quand ledit clapet (220) se trouve dans ladite première position, l'un desdits actionneurs (170, 172) est connecté par le biais dudit clapet (200) audit accumulateur (220) et l'autre desdits actionneurs (170, 172) est connecté au drain (196), et, quand ledit clapet (200) se trouve dans ladite deuxième position, ledit un desdits actionneurs (170, 172) est connecté au drain (196) et ledit autre desdits actionneurs (170, 172) est connecté par l'intermédiaire dudit clapet (200) audit accumulateur (220).
 4. Machine hydraulique rotative selon la revendication 3 dans laquelle chacun desdits actionneurs (170, 172) est à simple action.
 5. Machine hydraulique rotative selon la revendication 4 dans laquelle chacun desdits actionneurs (170, 172) est un actionneur linéaire ayant un piston (176) pouvant être déplacé dans un cylindre (174).
 6. Machine hydraulique rotative selon la revendication 5 dans laquelle chacun desdits actionneurs (170, 172) inclut un ressort (184) pour solliciter ledit actionneur (170, 172) à une capacité maximale.
 7. Machine hydraulique rotative selon la revendication 6 dans laquelle l'un desdits ressorts (184) a une plus grande sollicitation que l'autre pour déplacer ledit ensemble d'ajustement (142) jusqu'à une position de capacité maximale en l'absence de fluide sous pression dans ledit accumulateur (220).
 8. Machine hydraulique rotative selon l'une quelconque des revendications 1-6 dans laquelle ledit accumulateur (220) inclut un piston (222) pouvant être déplacé dans un cylindre (224) par application de pression de fluide à l'encontre d'une sollicitation de ressort (226).
 9. Machine hydraulique rotative selon la revendication 8 dans laquelle une butée (228) est prévue pour limiter le déplacement dudit piston (222) et limiter ainsi la force appliquée par ledit ressort (226).
 10. Machine hydraulique rotative selon la revendication 9 dans laquelle ledit ressort (226) est un ressort mécanique situé dans ledit cylindre (224).
 11. Machine hydraulique rotative selon la revendication 10 dans laquelle ledit ressort (226) est un ressort hélicoïdal et ladite butée (228) se situe dans ledit cylindre (224) et s'étend à travers ledit ressort hélicoïdal (226).
 12. Machine hydraulique rotative selon l'une quelconque des revendications 1-6 dans laquelle ledit clapet (200) et ledit accumulateur (230) se situent chacun dans des trous respectifs (193, 194) dudit boîtier (12) et sont interconnectés par une galerie interne (195).
 13. Machine hydraulique rotative selon la revendication 12 dans laquelle ledit premier desdits orifices (78, 79) est connecté par un trou interne (232) audit accumulateur (220) et ledit clapet de retenue (230) se situe dans ledit trou interne (232).
 14. Machine hydraulique rotative selon la revendication 13 dans laquelle ledit trou interne (232) est connecté à ladite galerie interne (195) pour apporter du fluide audit accumulateur (220) et audit clapet (200).
 15. Machine hydraulique rotative selon l'une quelconque des revendications 1-14 dans laquelle ledit clapet (200) est un clapet à centre fermé pour empêcher l'écoulement de fluide à travers ledit clapet (200) en l'absence d'un signal de commande pour ajuster ladite course desdits actionneurs (170, 172).

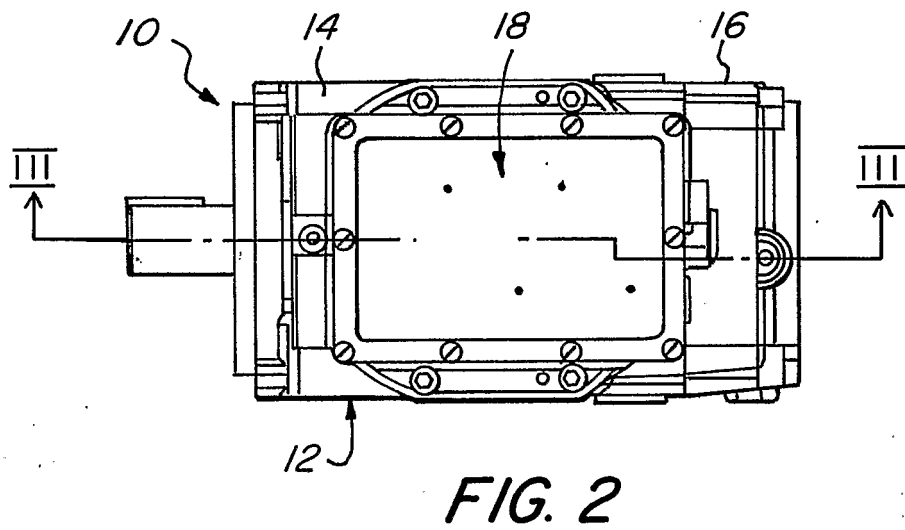
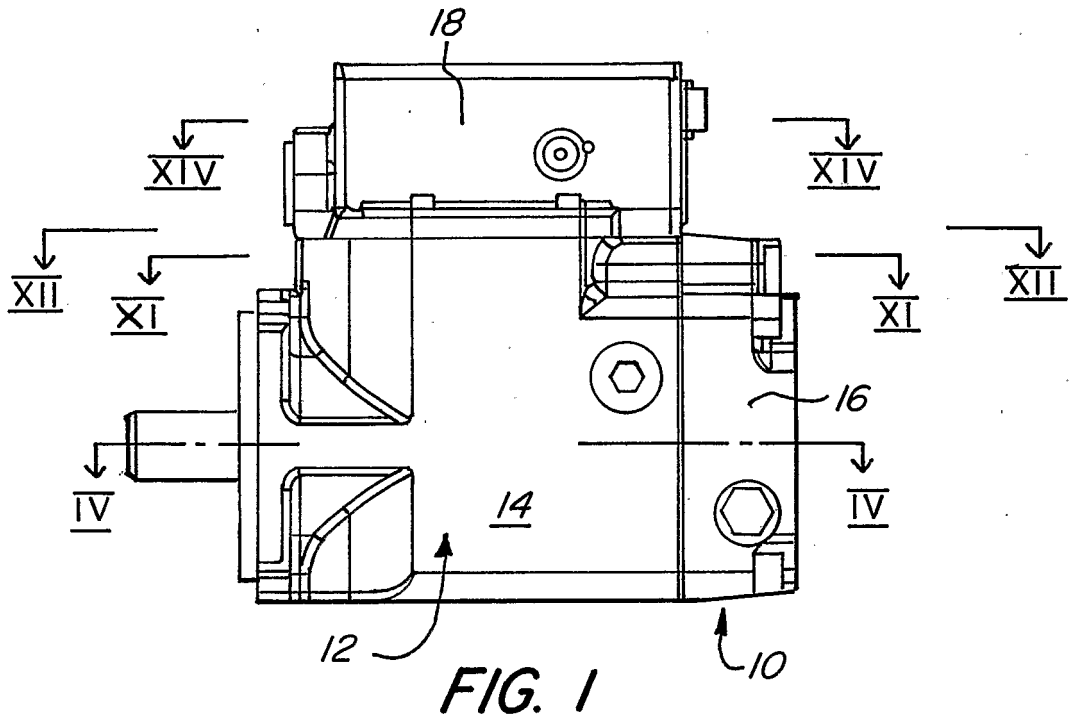

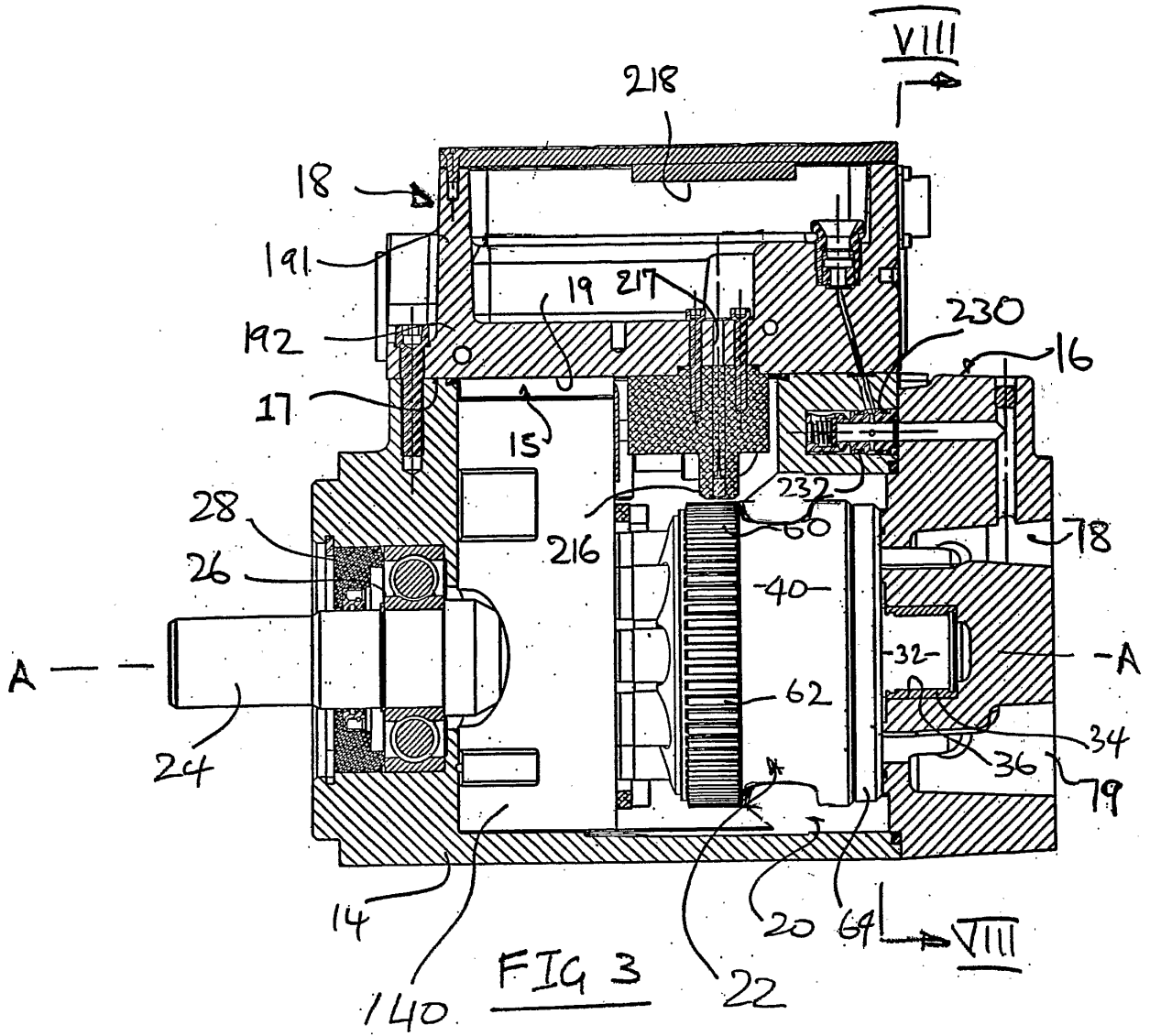

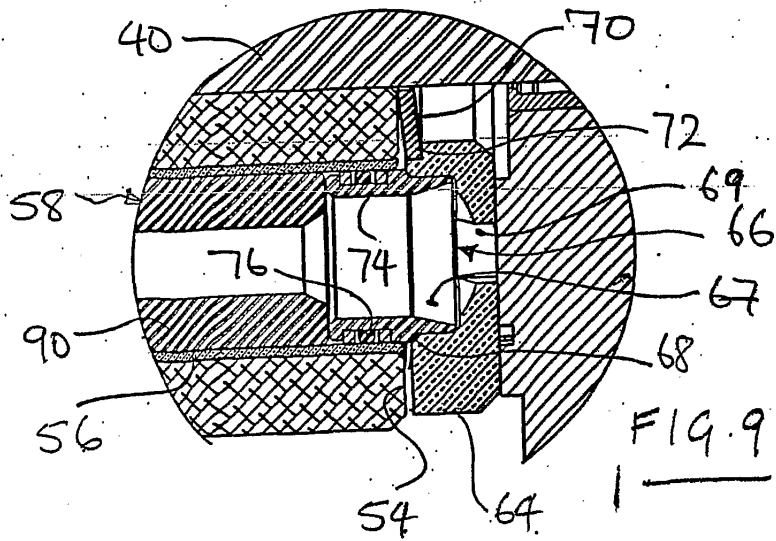
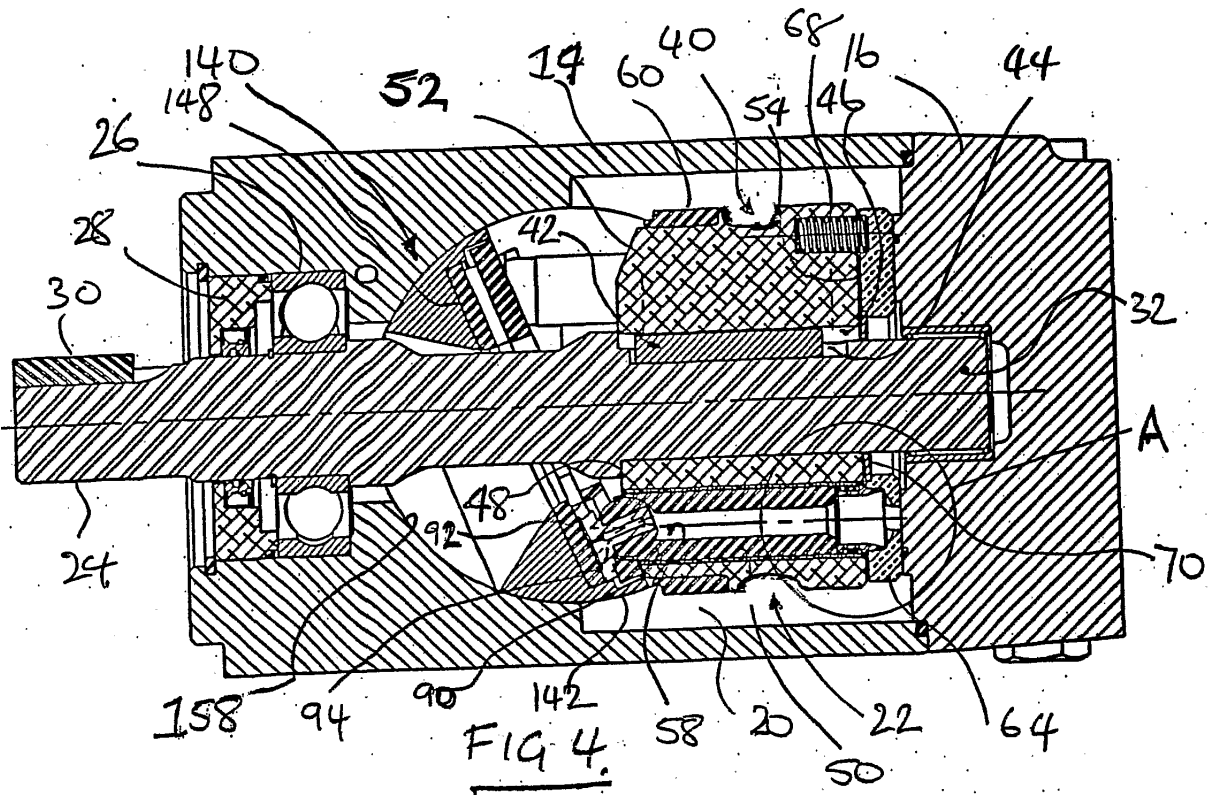

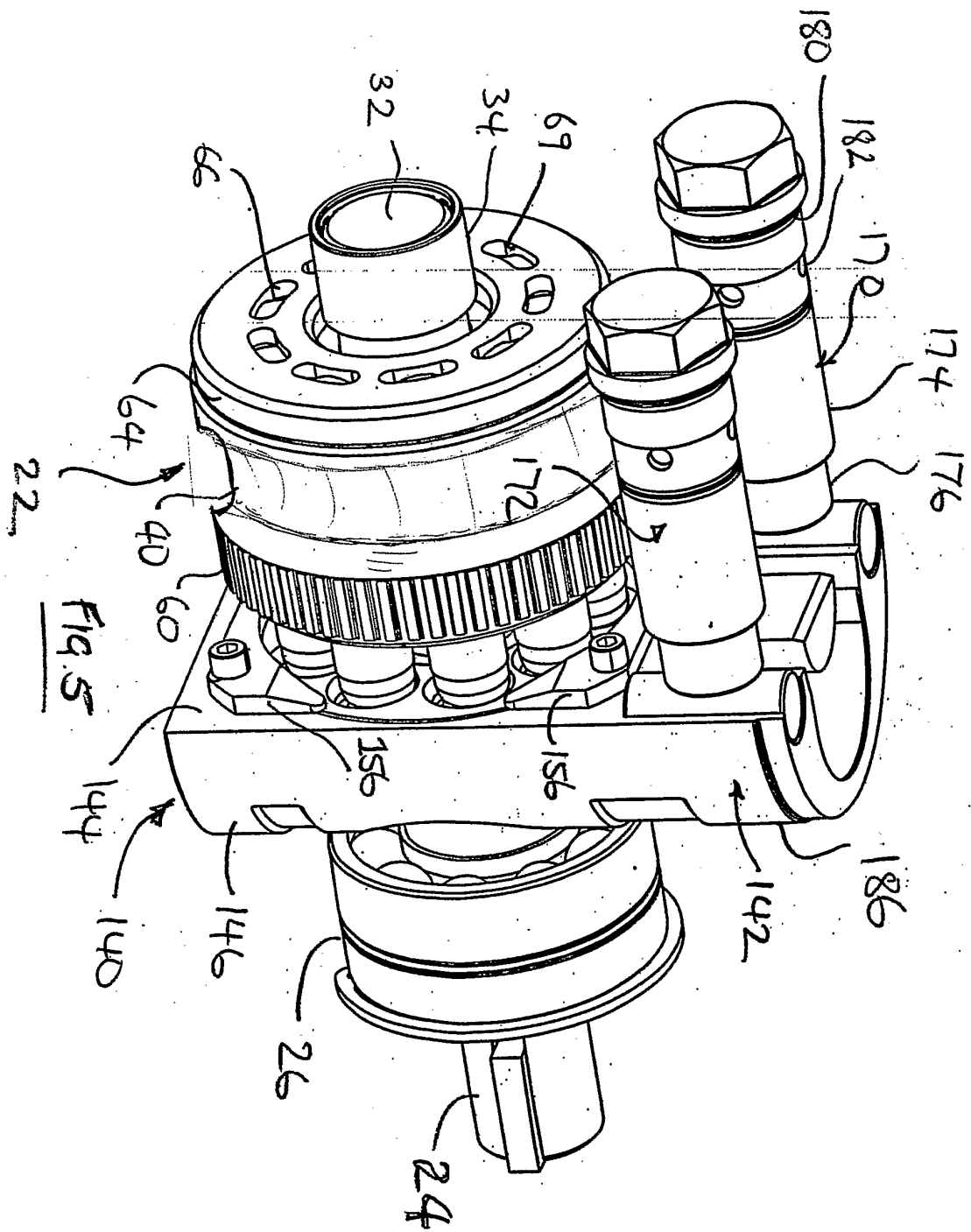

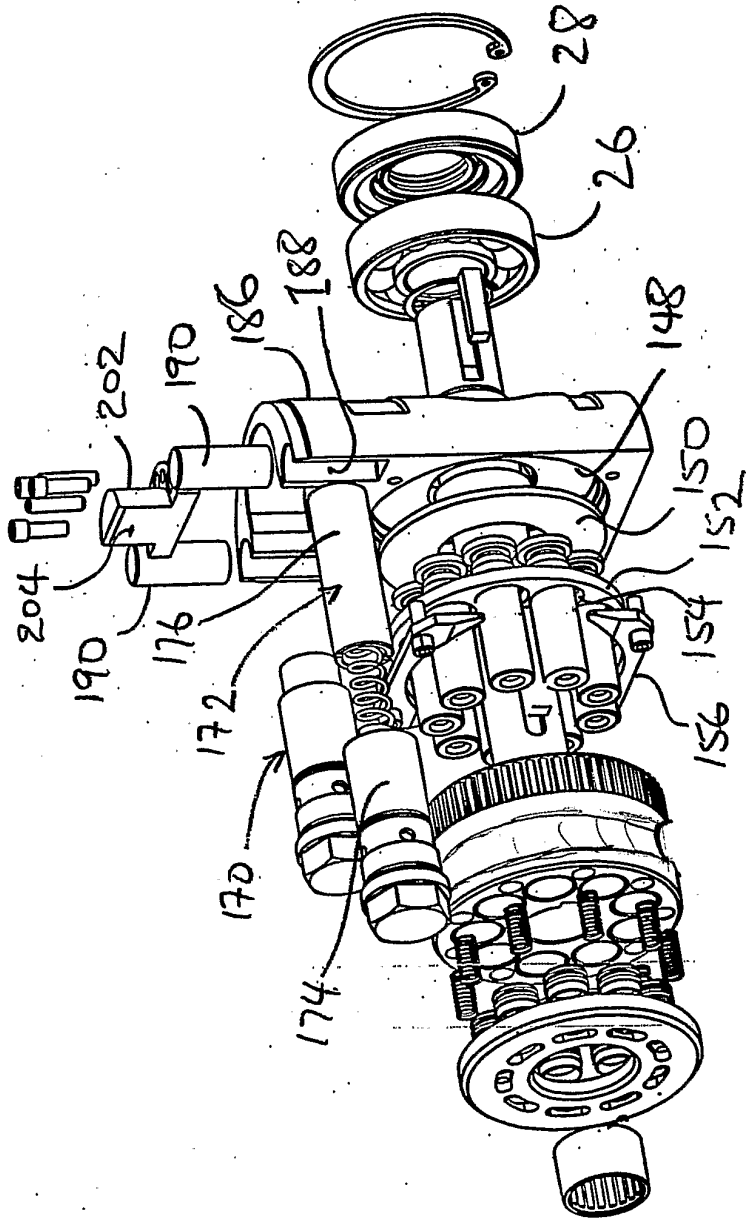

FIG. 6

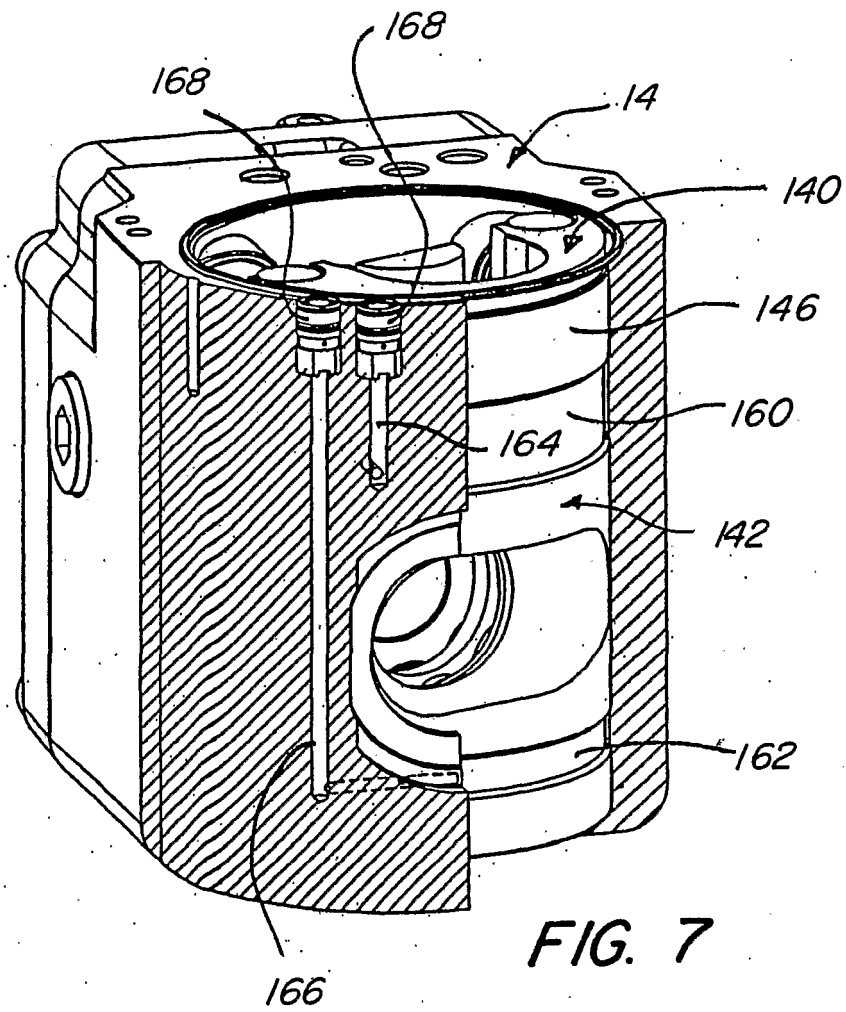

FIG. 7

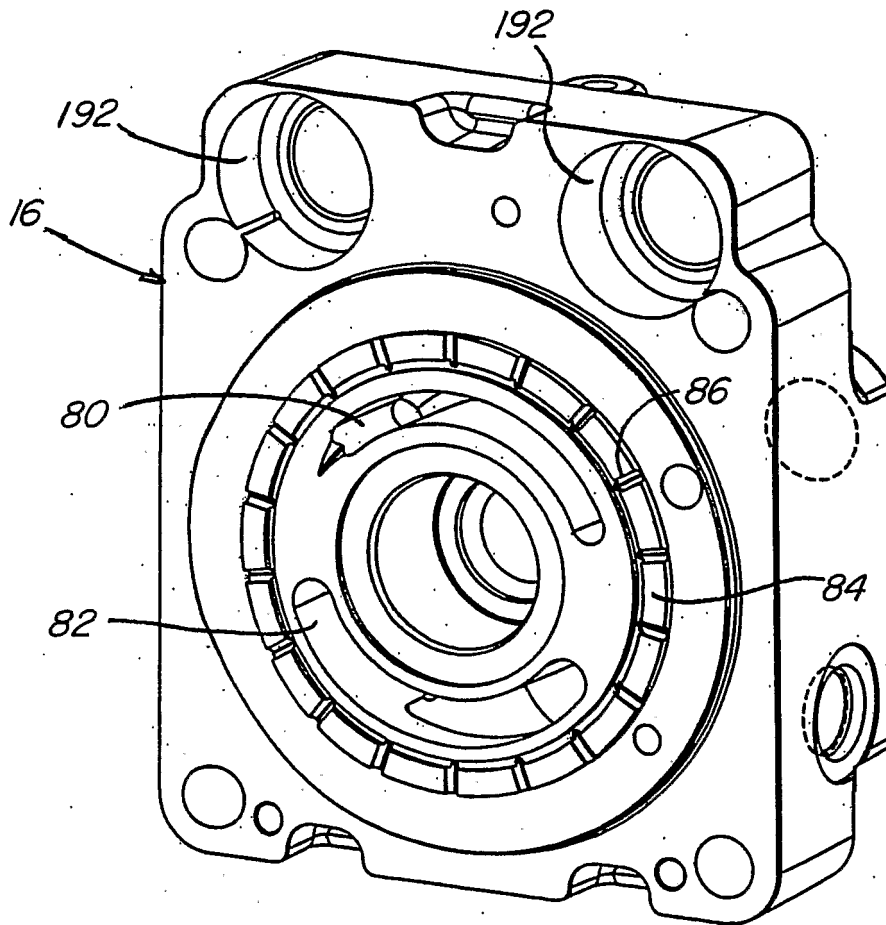

FIG. 8

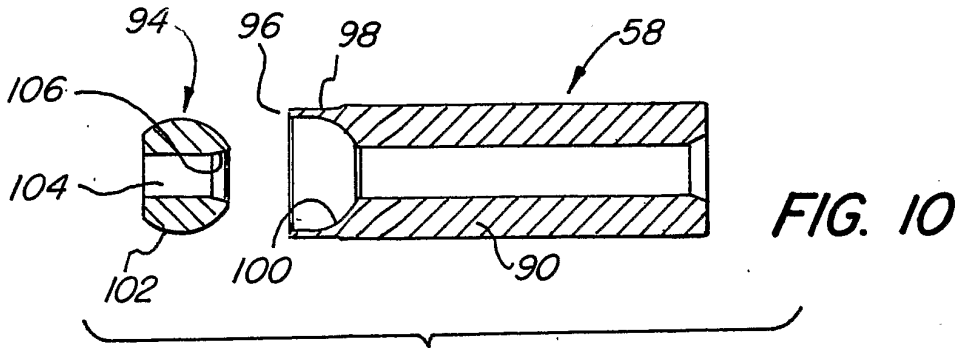

FIG. 10

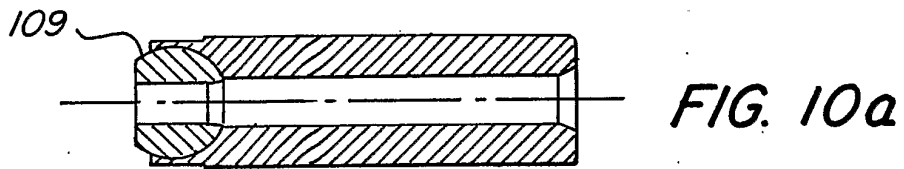

FIG. 10a

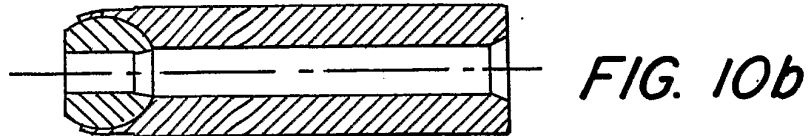

FIG. 10b

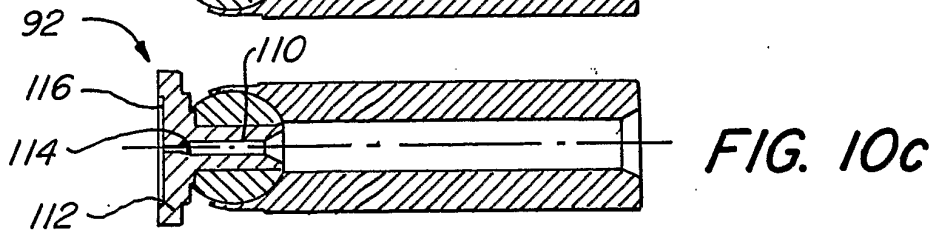

FIG. 10c

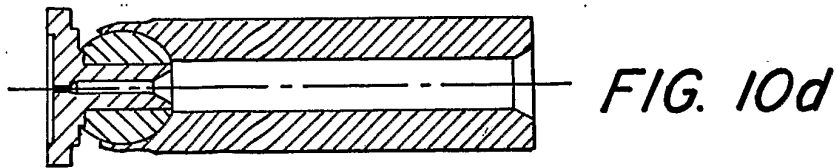

FIG. 10d

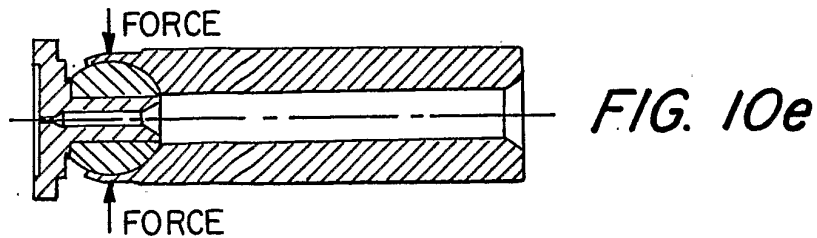

FIG. 10e

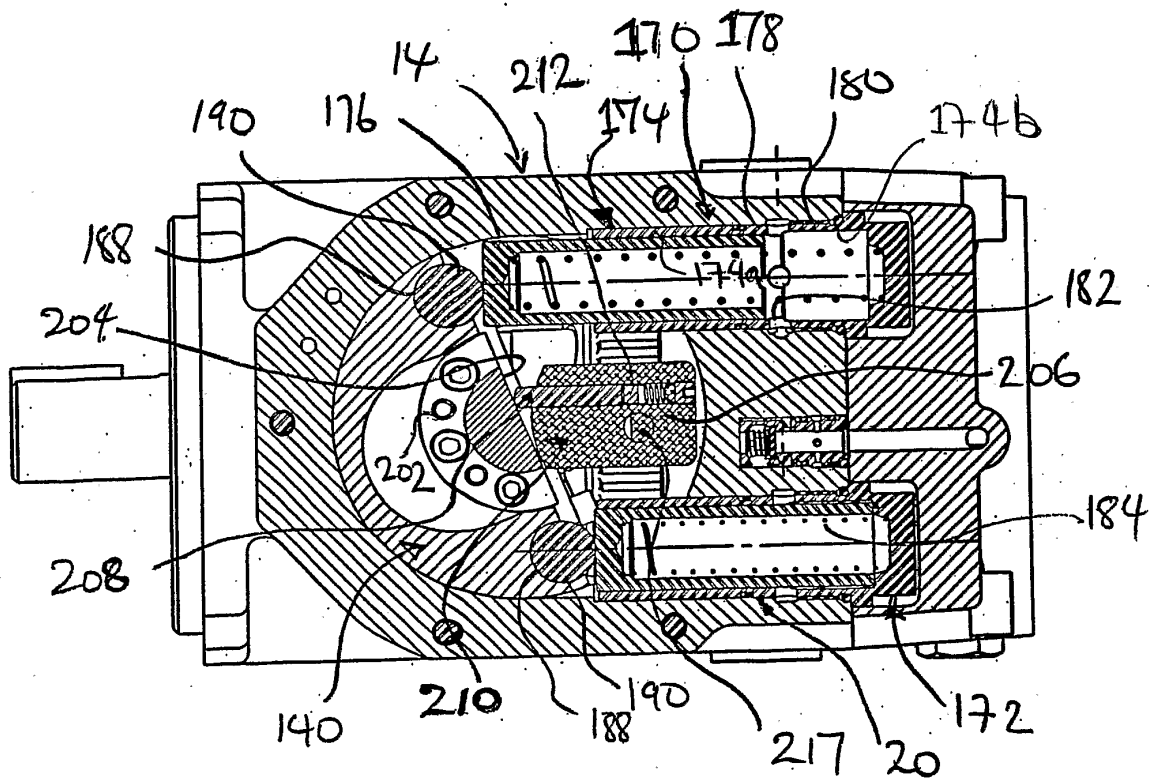

FIG. 11

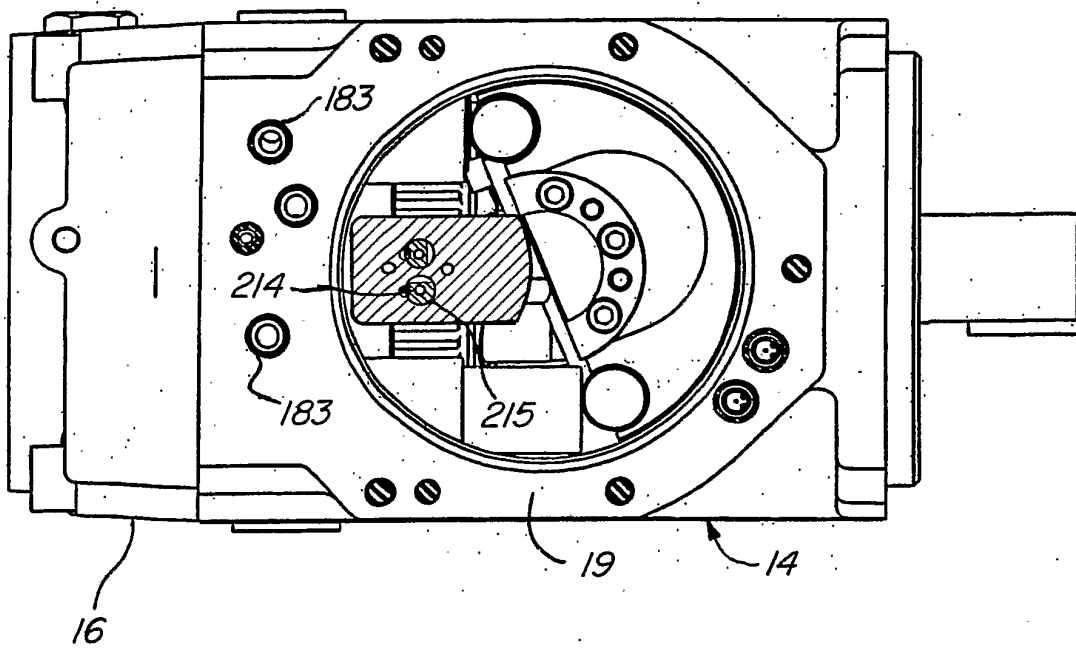

FIG. 12

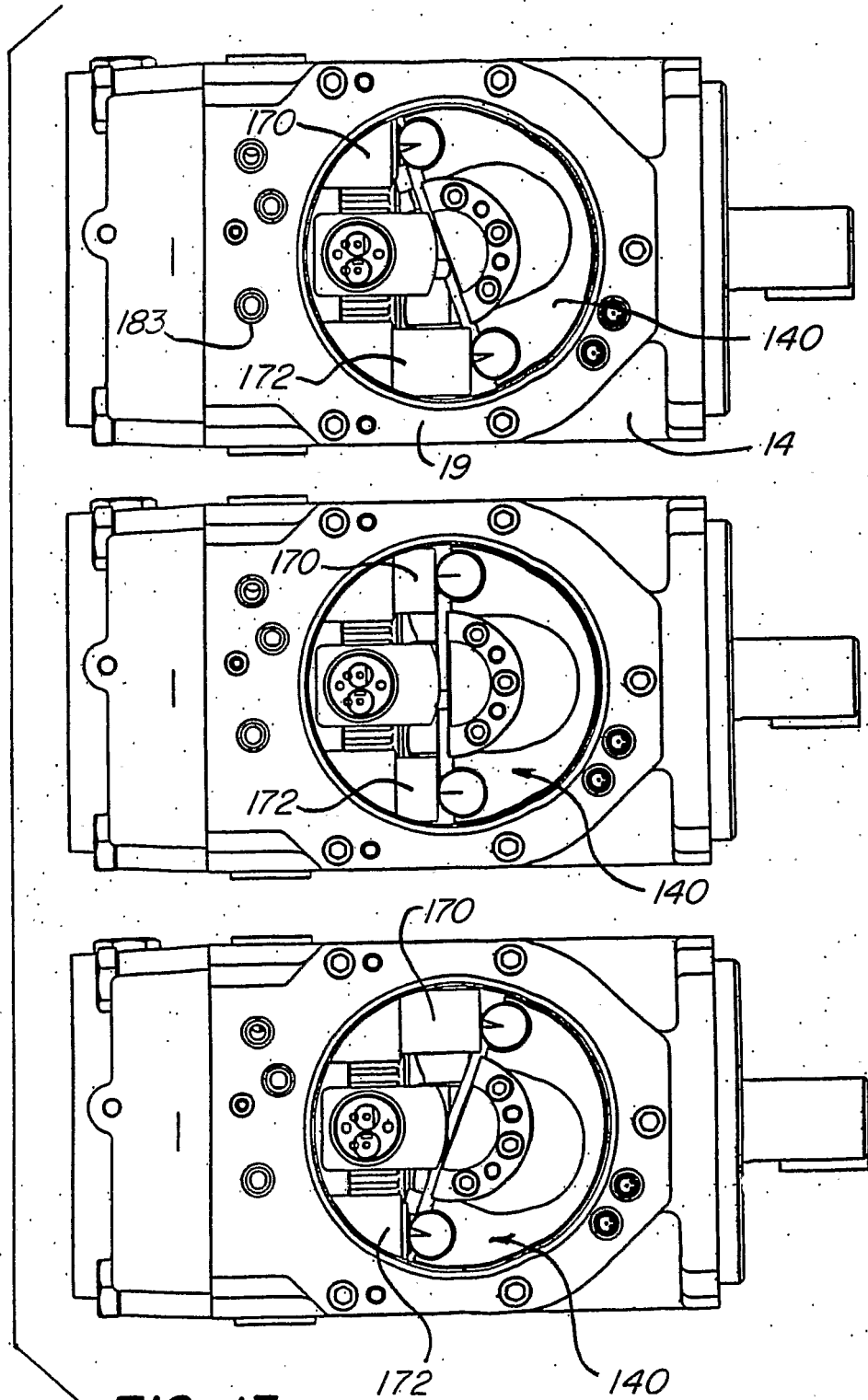

FIG. 13

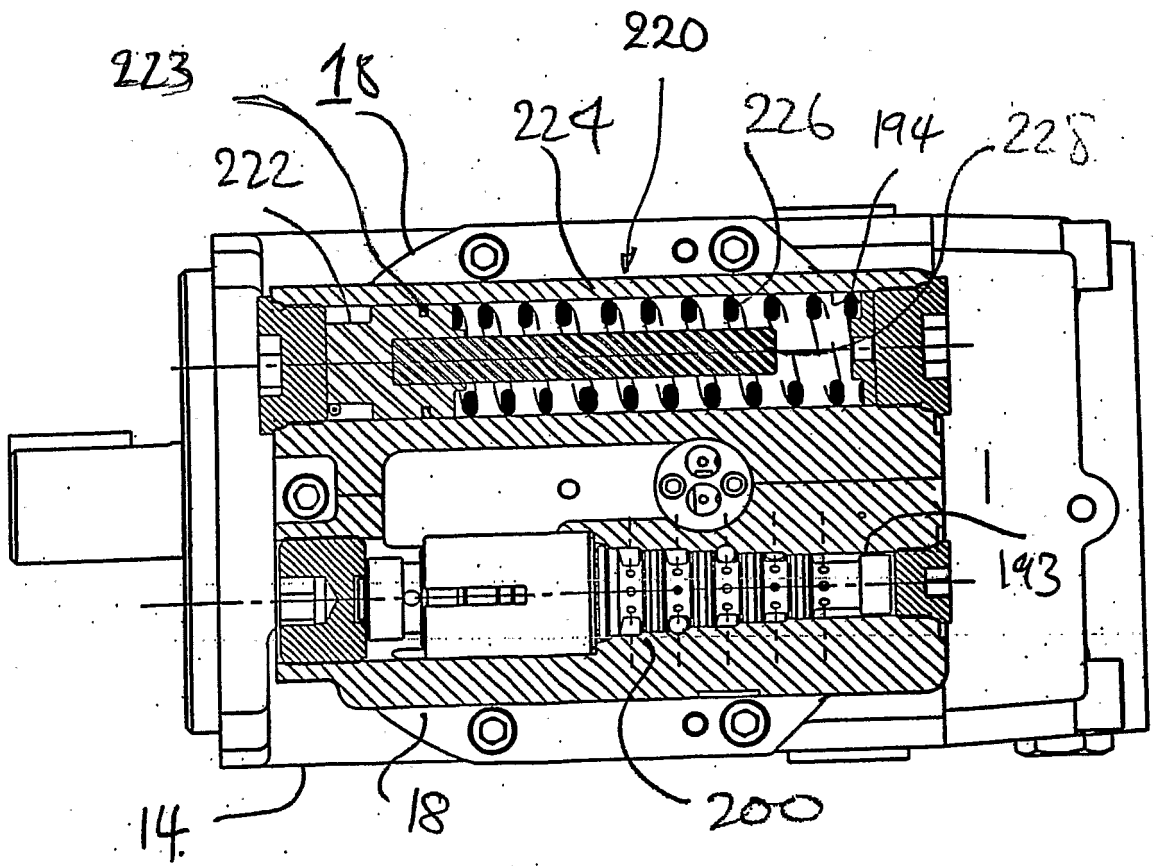

FIG. 14

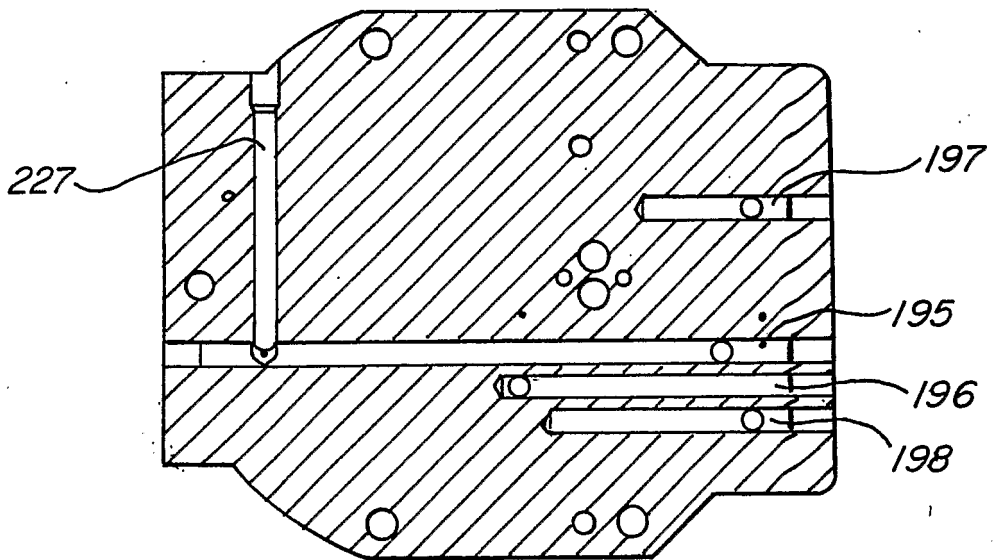
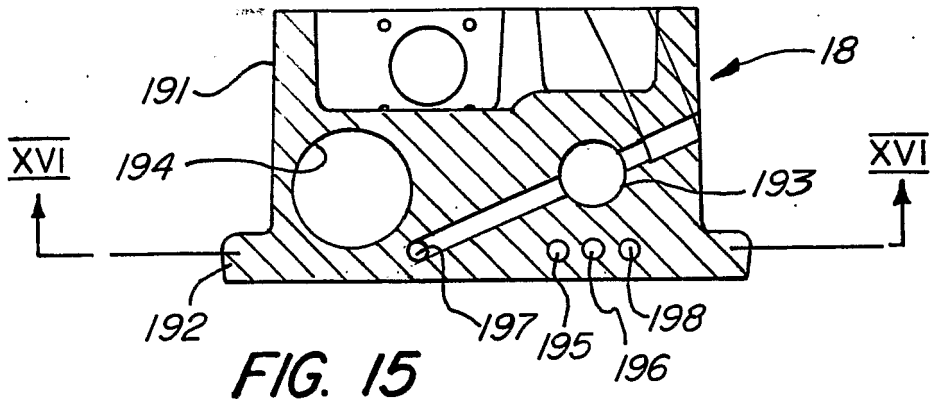

FIG. 16

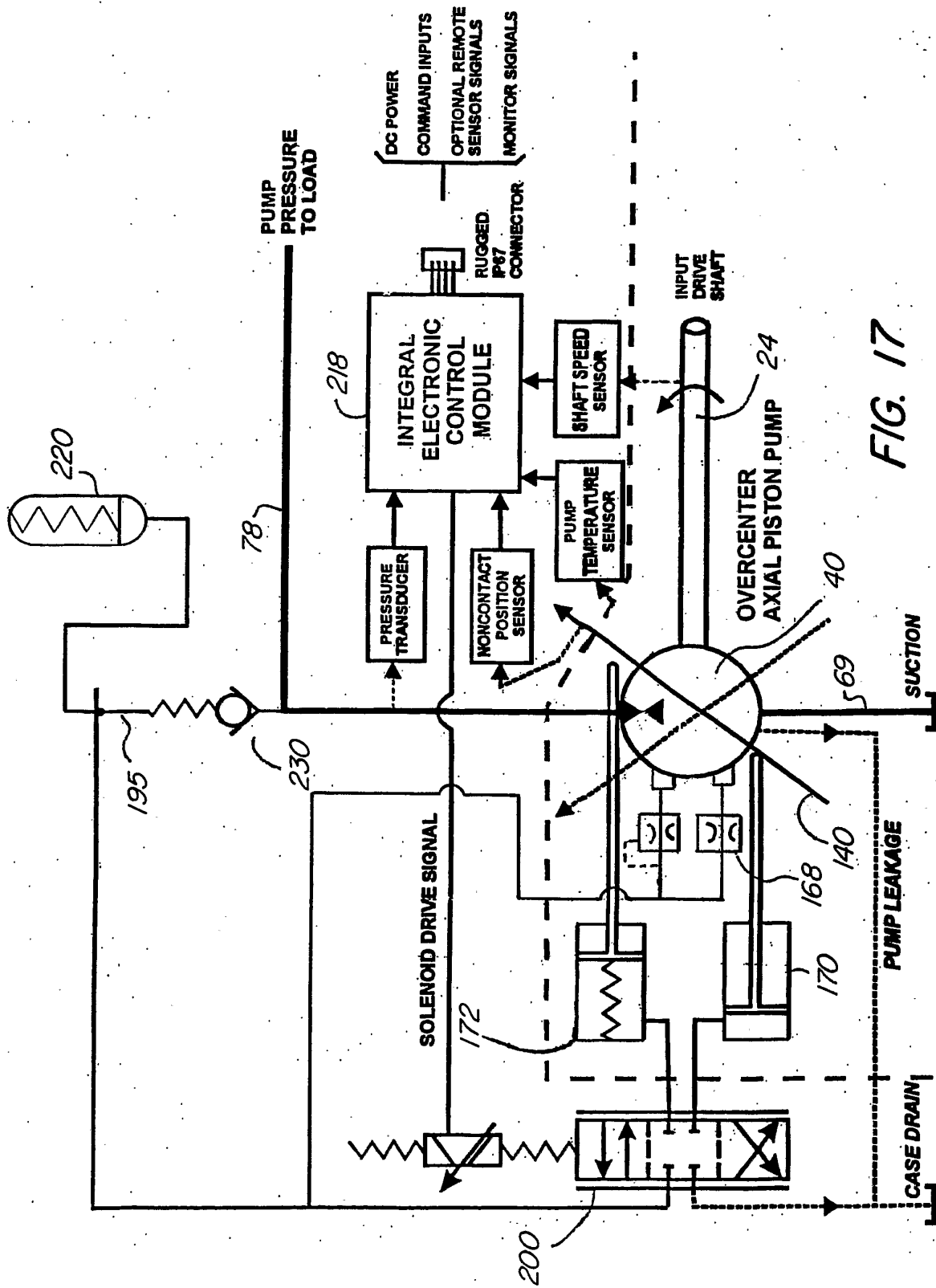

FIG. 17

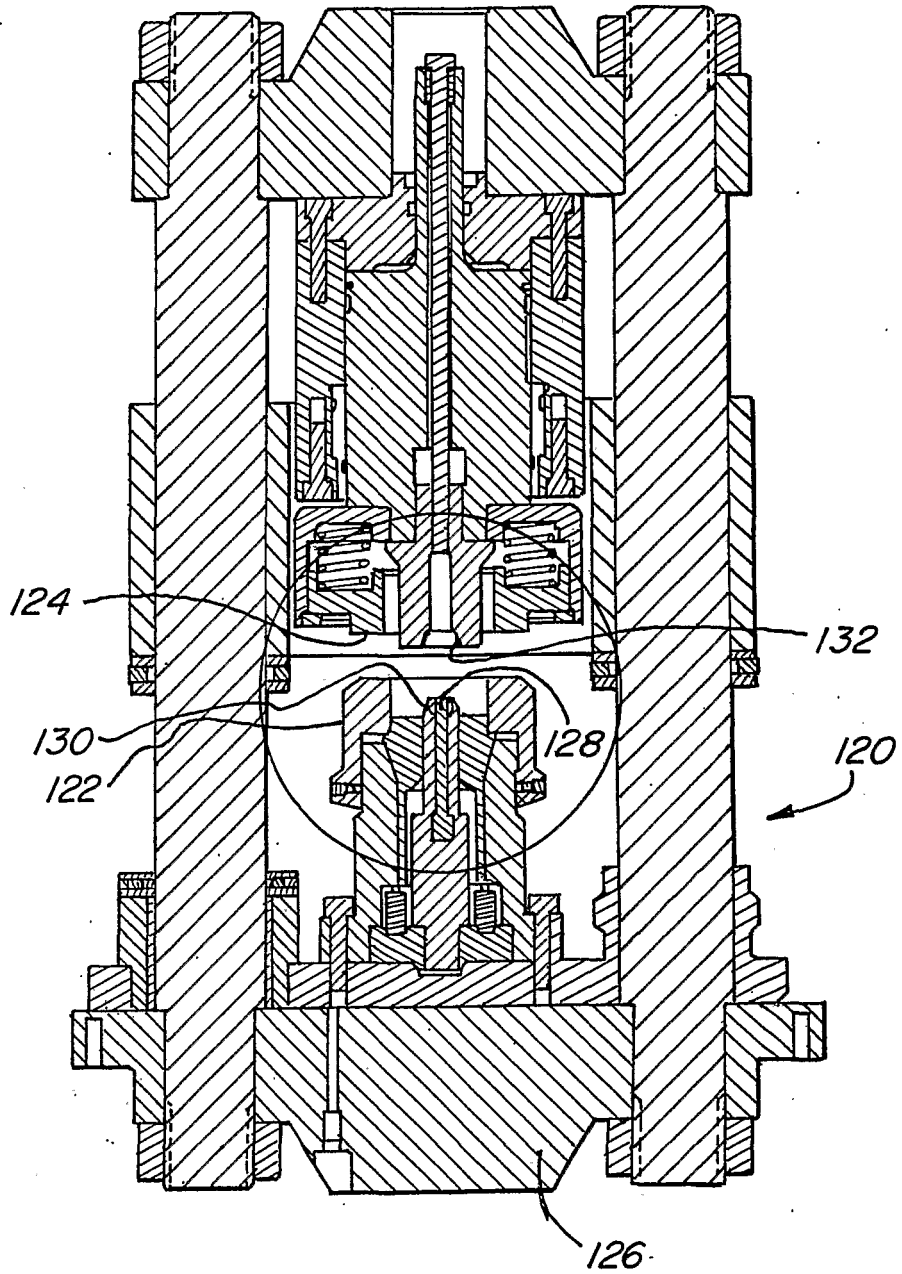

FIG. 18

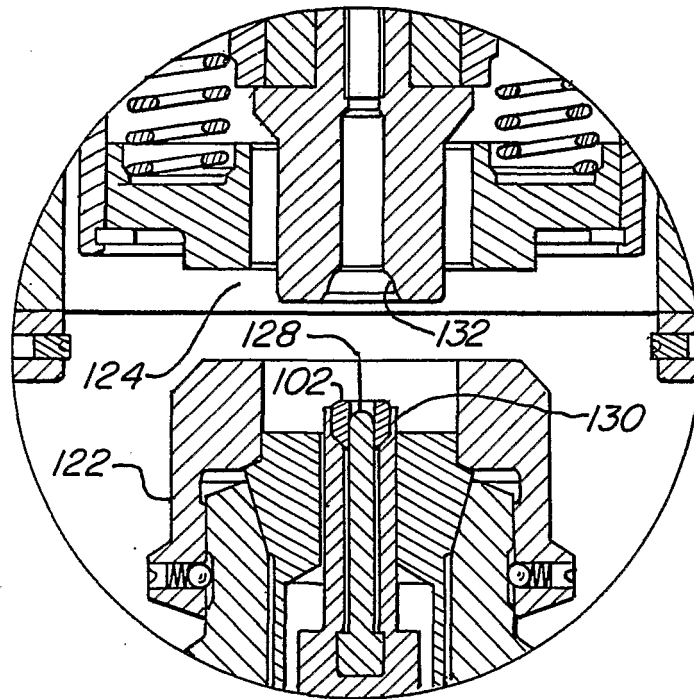

FIG. 19

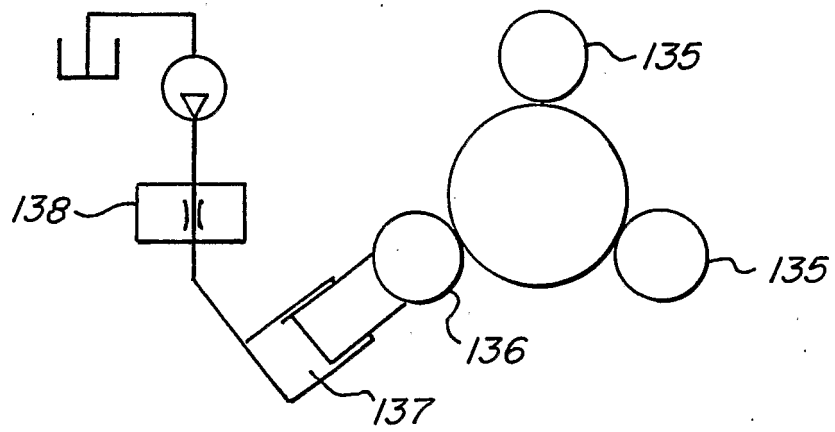
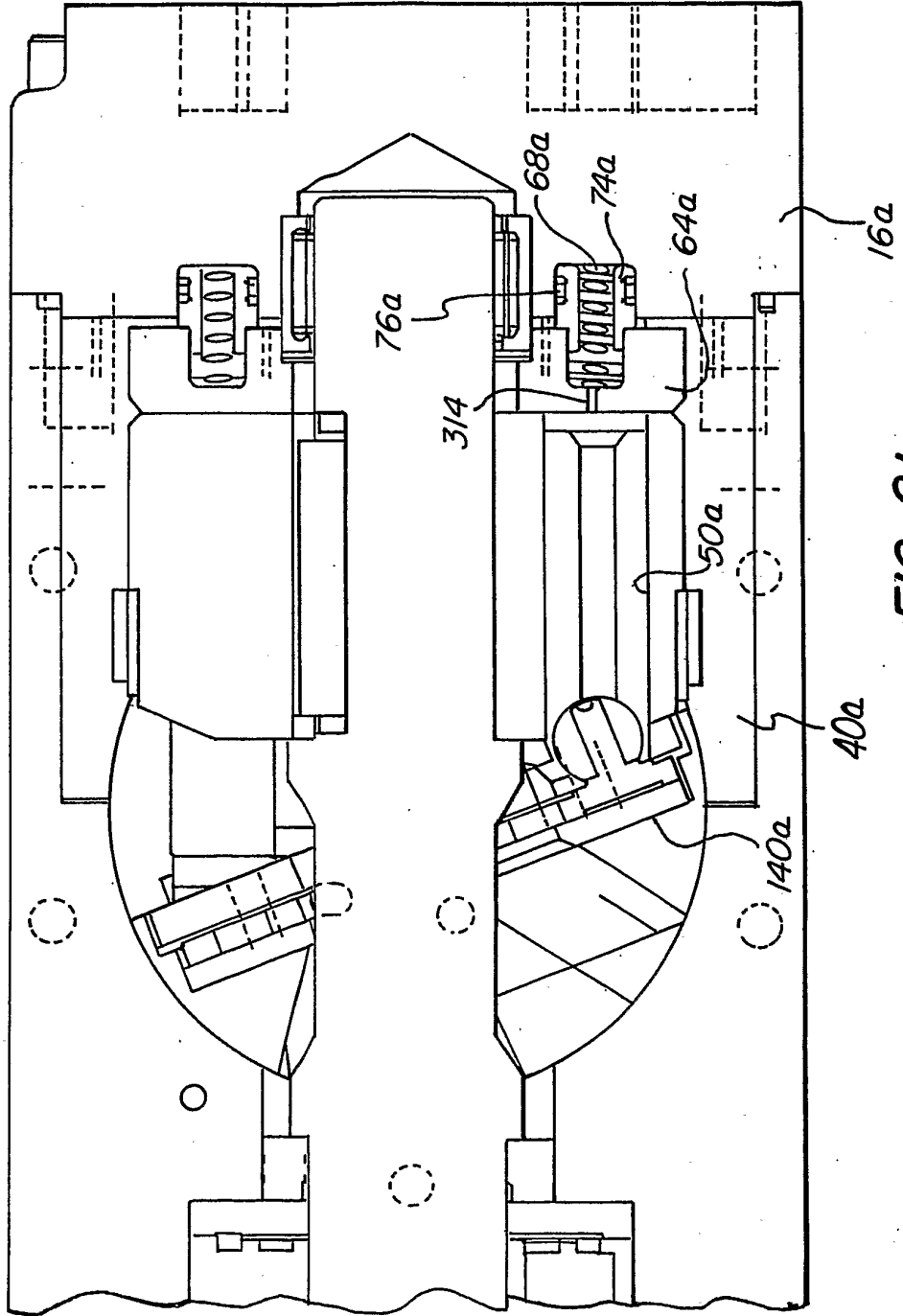

FIG. 20



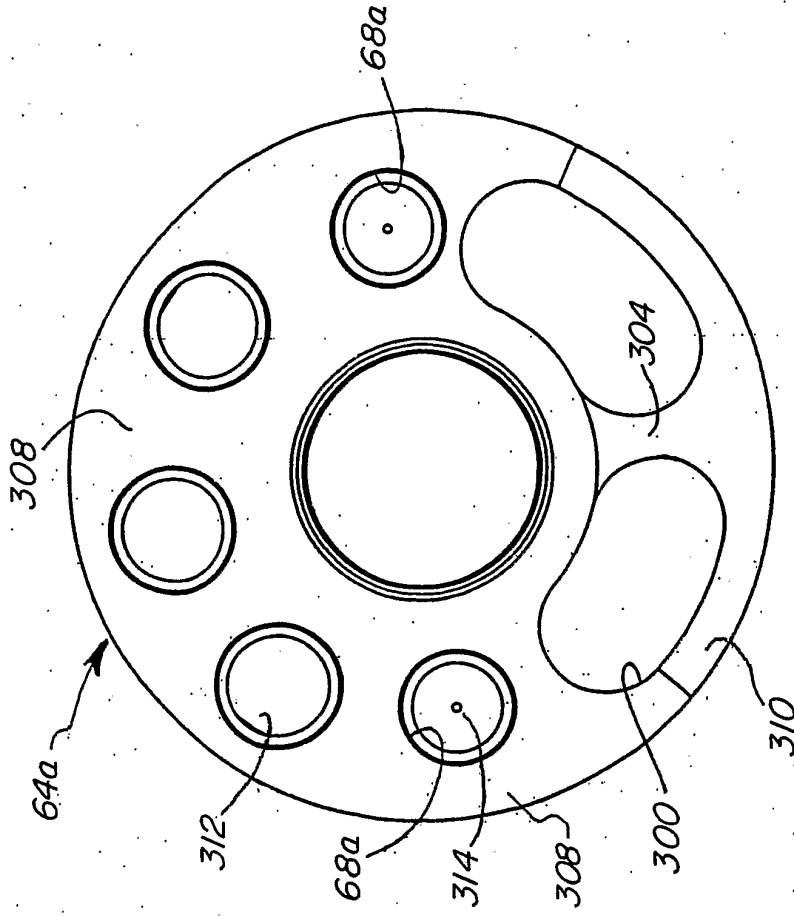

FIG. 24

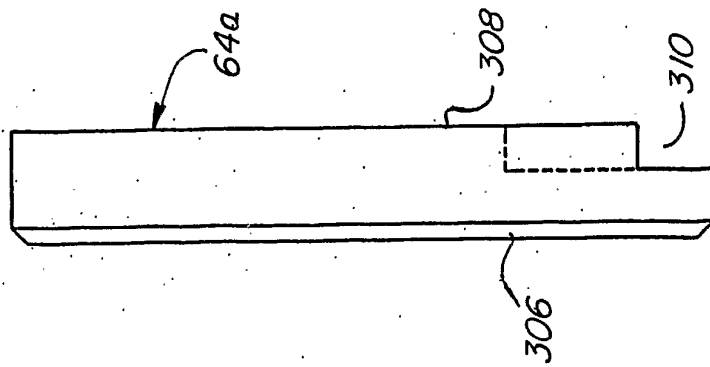

FIG. 23

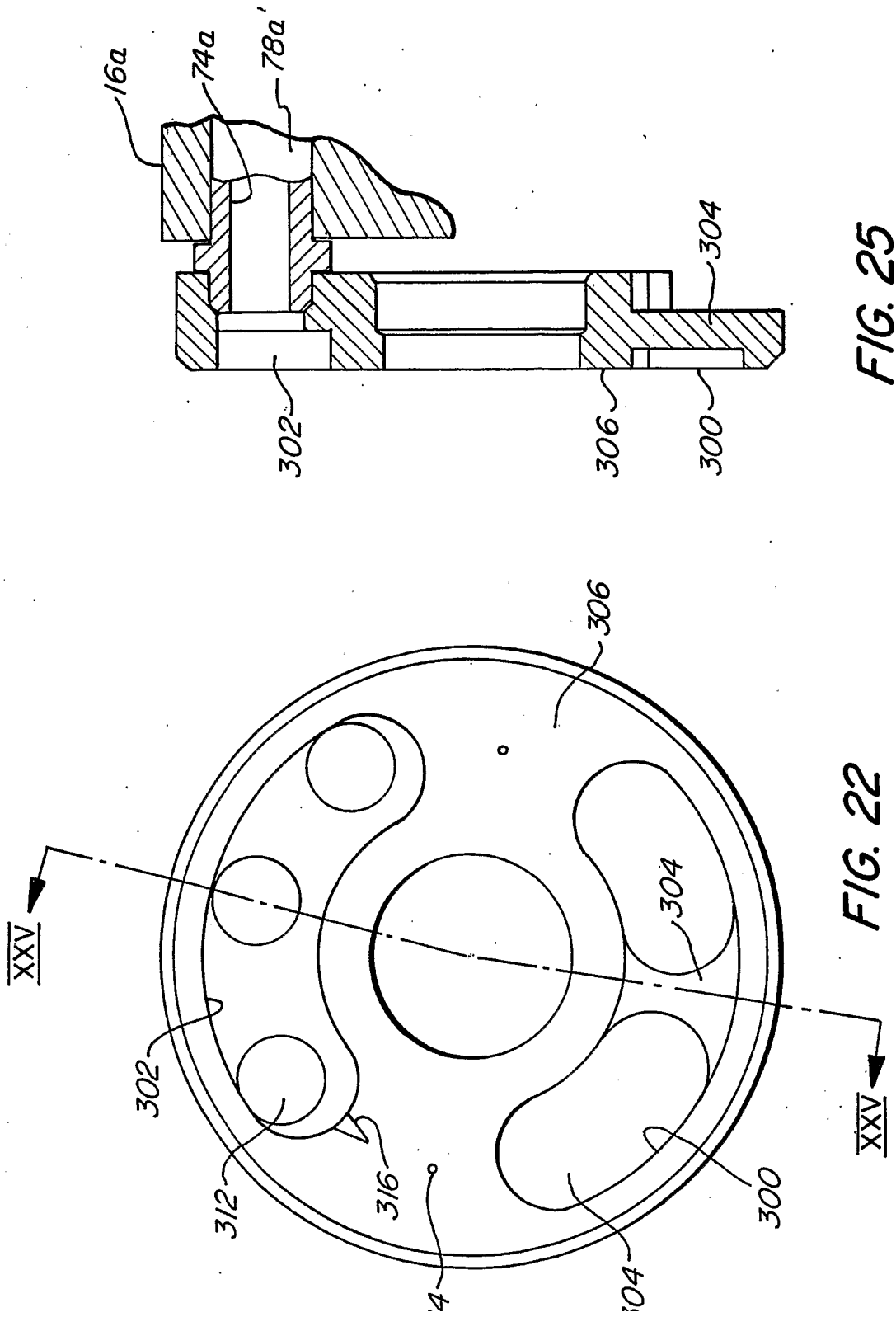

FIG. 25

FIG. 22

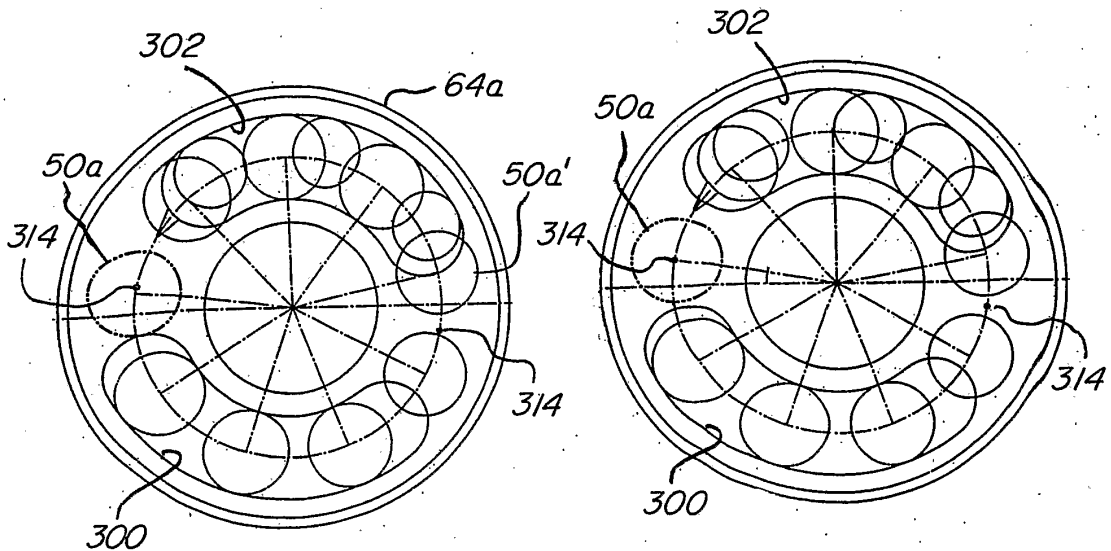

FIG. 26A

FIG. 26B

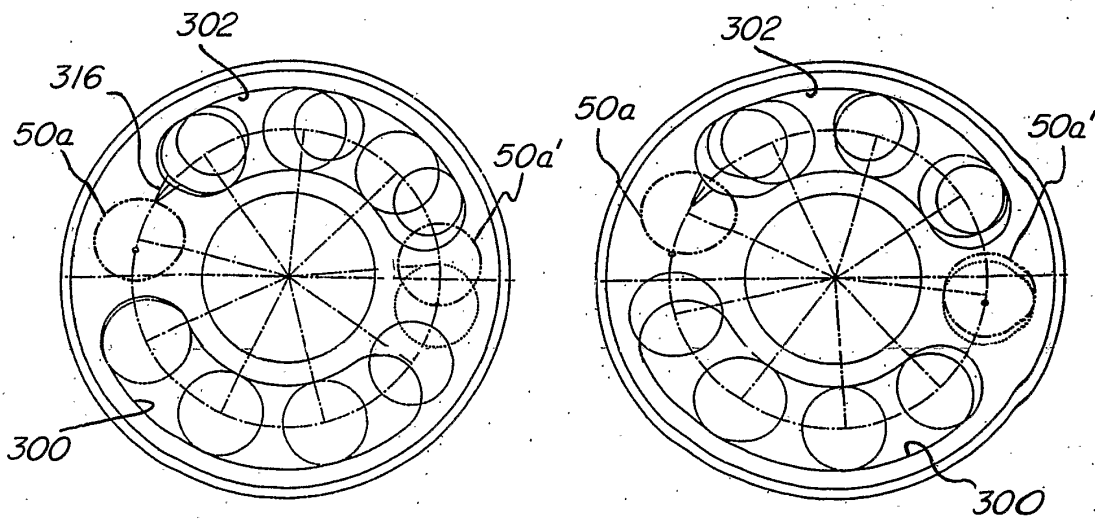

FIG. 26C

FIG. 26D

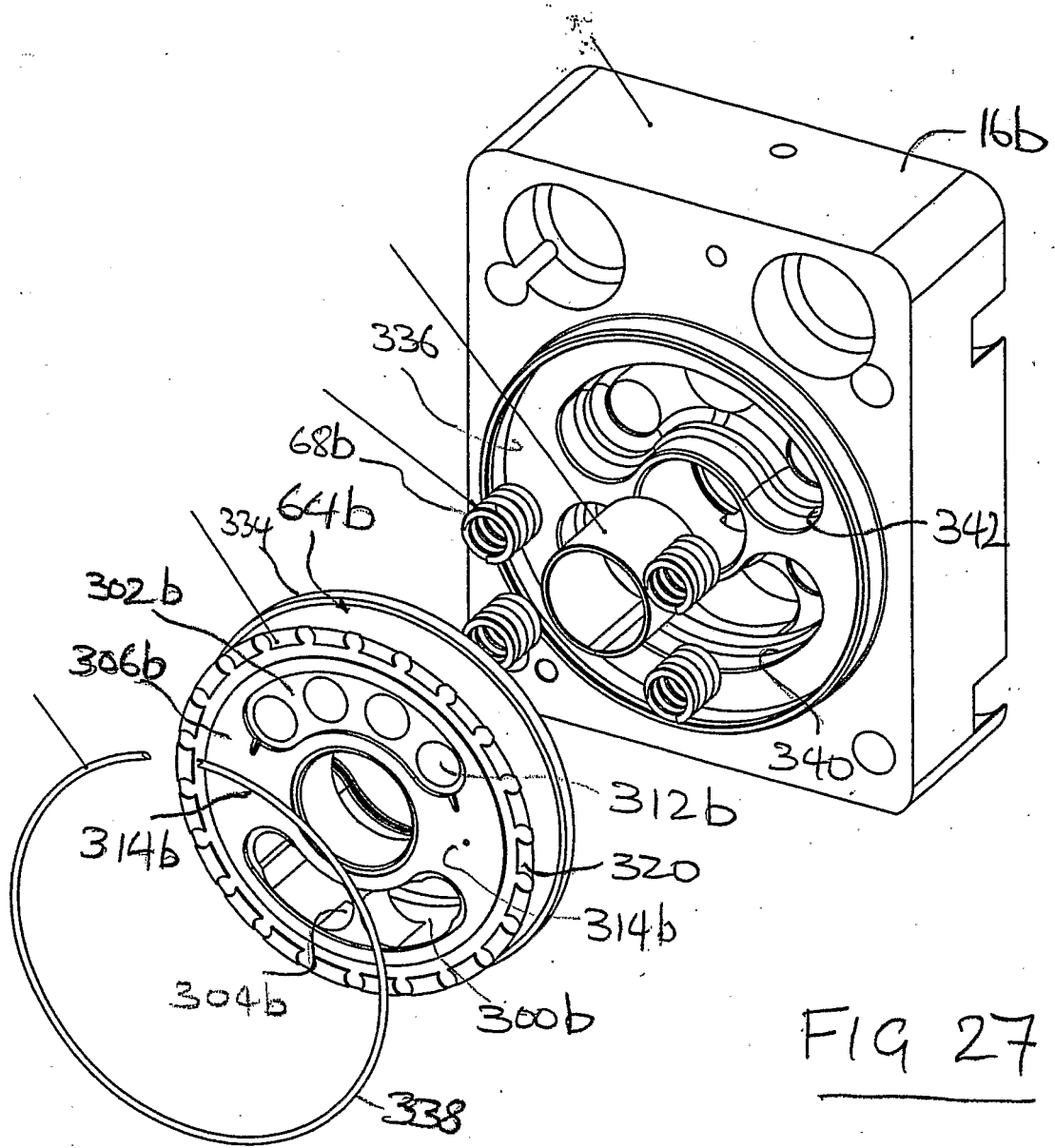

FIG 27

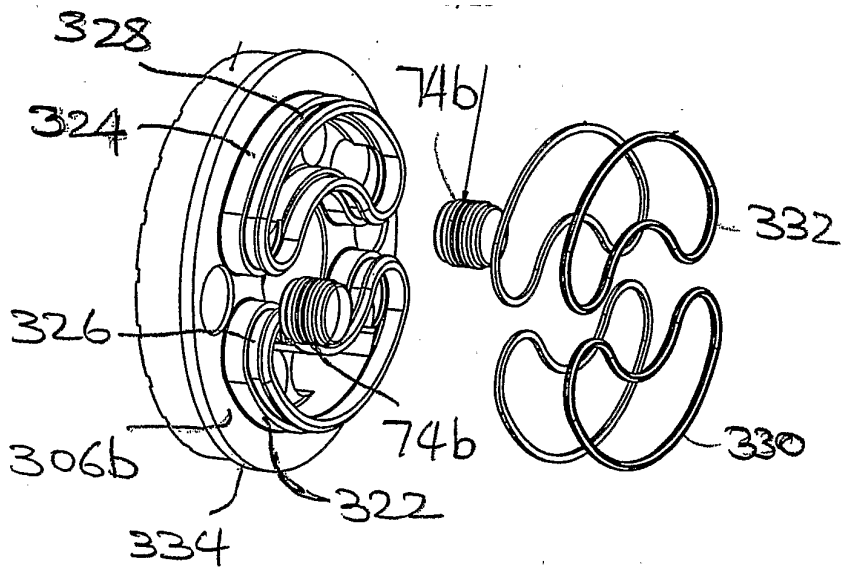

FIG 28

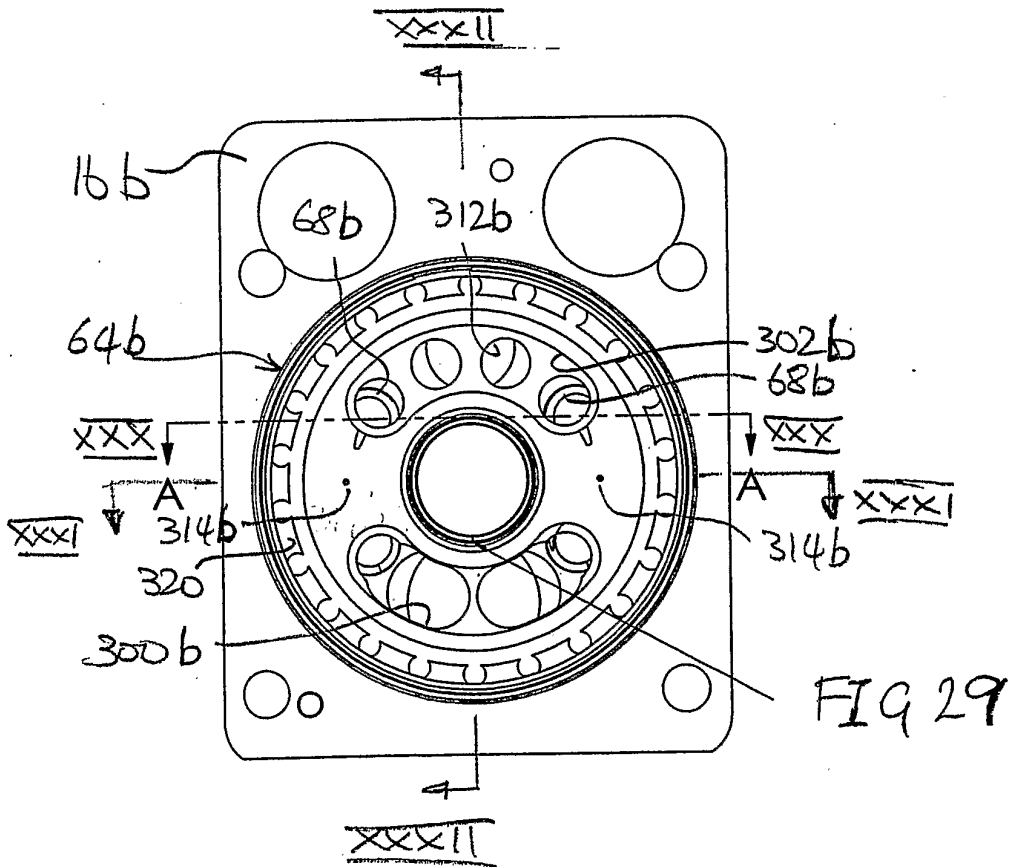

FIG 29

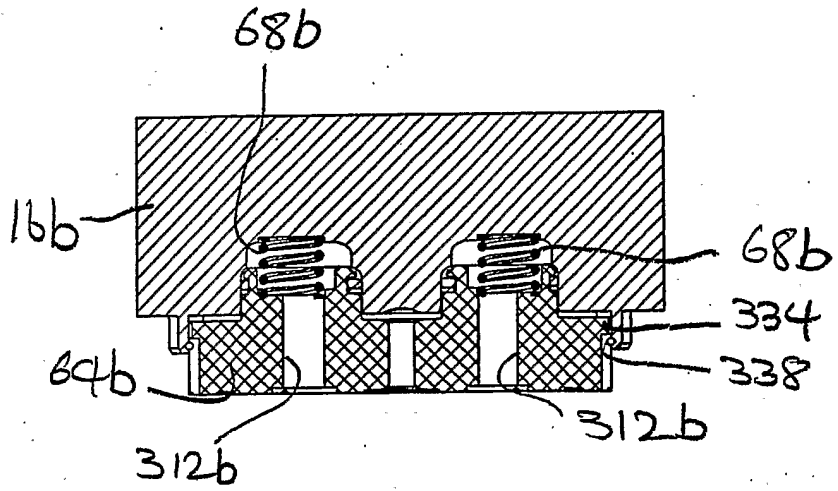

FIG 30

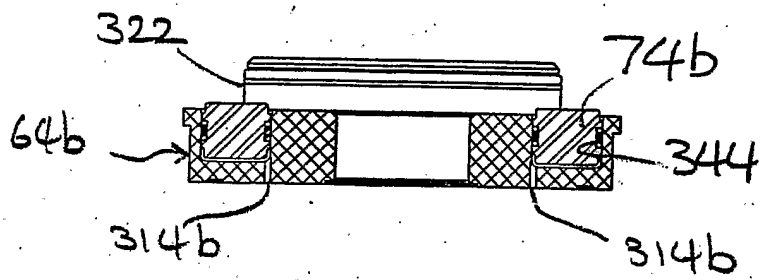

FIG 31

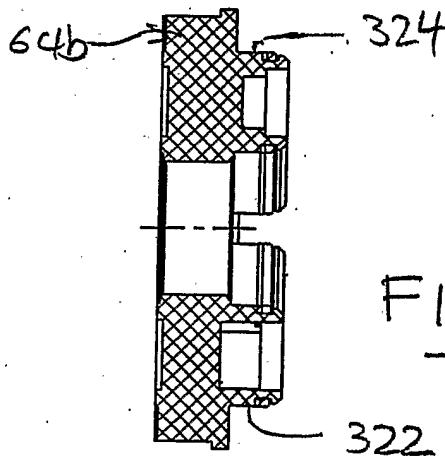

FIG 32

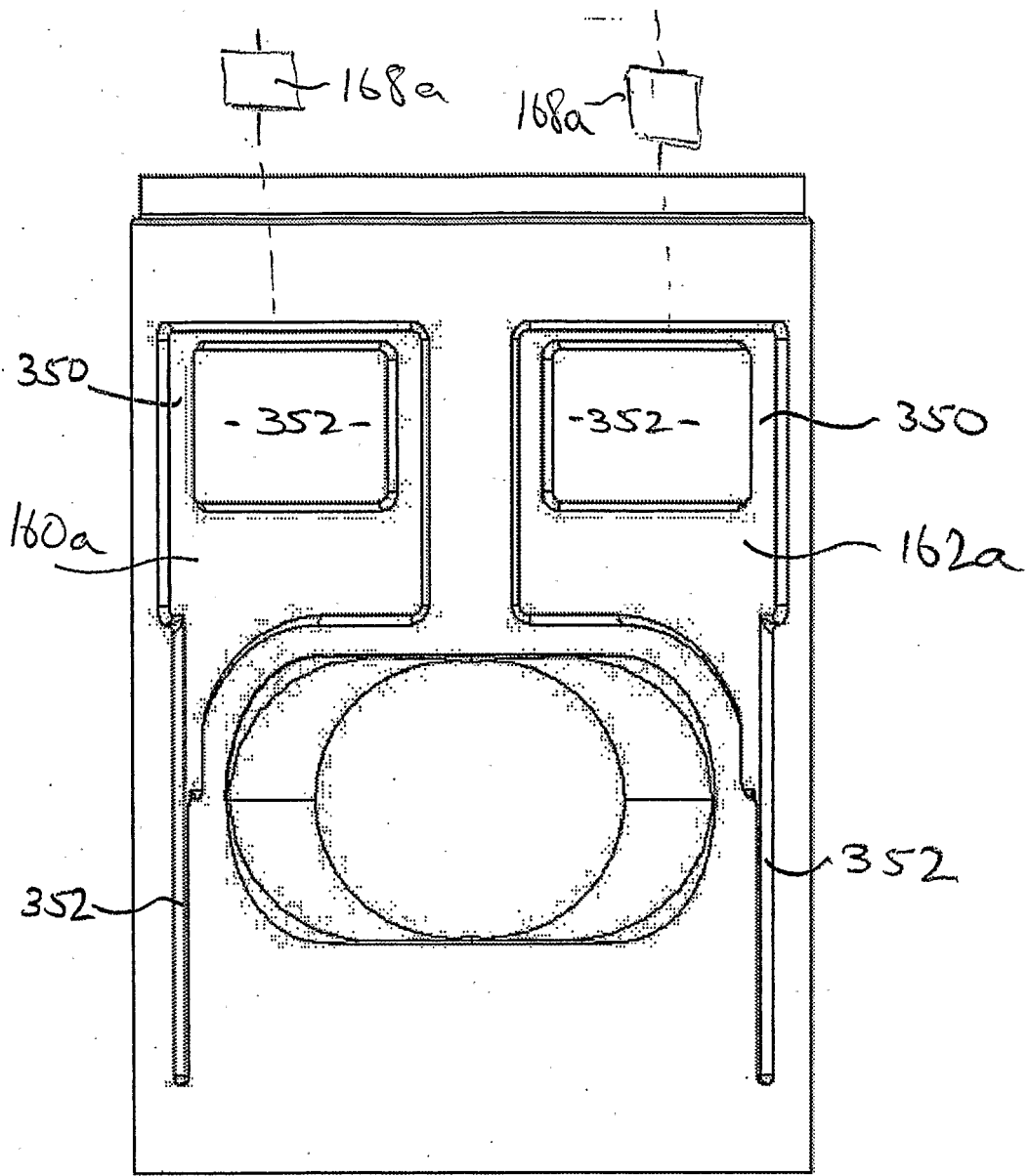

FIG 33

REFERENCES CITED IN THE DESCRIPTION

This list of references cited by the applicant is for the reader's convenience only. It does not form part of the European patent document. Even though great care has been taken in compiling the references, errors or omissions cannot be excluded and the EPO disclaims all liability in this regard.

Patent documents cited in the description

- US 3306209 A [0008]