



(51) International Patent Classification:

B32B 21/14 (2006.01) *B44C 5/04* (2006.01)
B27D 1/06 (2006.01) *B32B 21/02* (2006.01)

(21) International Application Number:

PCT/SE2015/050524

(22) International Filing Date:

11 May 2015 (11.05.2015)

(25) Filing Language:

English

(26) Publication Language:

English

(30) Priority Data:

1450552-3	12 May 2014 (12.05.2014)	SE
1451154-7	29 September 2014 (29.09.2014)	SE
PCT/SE2015/050008		
	9 January 2015 (09.01.2015)	SE
14/593,458	9 January 2015 (09.01.2015)	US

(71) Applicant: **VÄLINGE INNOVATION AB** [SE/SE];
Prästavägen 513, SE-263 65 Viken (SE).

(72) Inventors: **ZIEGLER, Göran**; Hästhovsvägen 11, SE-263 62 Viken (SE). **MEIJER, Thomas**; Hallonvägen 23, SE-343 38 Älmhult (SE). **NYGREN, Per**; Surbrunnsgatan 15, SE-253 60 Ramlösa (SE). **LUNDBLAD, Christer**; Mattarp PI. 1502, SE-286 92 Örskälljunga (SE).

(74) Agent: **WESTEMAN, Maria**; Välinge Innovation AB, Prästavägen 513, SE-263 65 Viken (SE).

(81) Designated States (unless otherwise indicated, for every kind of national protection available): AE, AG, AL, AM, AO, AT, AU, AZ, BA, BB, BG, BH, BN, BR, BW, BY, BZ, CA, CH, CL, CN, CO, CR, CU, CZ, DE, DK, DM, DO, DZ, EC, EE, EG, ES, FI, GB, GD, GE, GH, GM, GT, HN, HR, HU, ID, IL, IN, IR, IS, JP, KE, KG, KN, KP, KR, KZ, LA, LC, LK, LR, LS, LU, LY, MA, MD, ME, MG, MK, MN, MW, MX, MY, MZ, NA, NG, NI, NO, NZ, OM, PA, PE, PG, PH, PL, PT, QA, RO, RS, RU, RW, SA, SC, SD, SE, SG, SK, SL, SM, ST, SV, SY, TH, TJ, TM, TN, TR, TT, TZ, UA, UG, US, UZ, VC, VN, ZA, ZM, ZW.

(84) Designated States (unless otherwise indicated, for every kind of regional protection available): ARIPO (BW, GH, GM, KE, LR, LS, MW, MZ, NA, RW, SD, SL, ST, SZ, TZ, UG, ZM, ZW), Eurasian (AM, AZ, BY, KG, KZ, RU, TJ, TM), European (AL, AT, BE, BG, CH, CY, CZ, DE, DK, EE, ES, FI, FR, GB, GR, HR, HU, IE, IS, IT, LT, LU, LV, MC, MK, MT, NL, NO, PL, PT, RO, RS, SE, SI, SK, SM, TR), OAPI (BF, BJ, CF, CG, CI, CM, GA, GN, GQ, GW, KM, ML, MR, NE, SN, TD, TG).

Declarations under Rule 4.17:

— as to applicant's entitlement to apply for and be granted a patent (Rule 4.17(ii))

Published:

— with international search report (Art. 21(3))

(54) Title: A METHOD OF PRODUCING A VENEERED ELEMENT AND SUCH A VENEERED ELEMENT

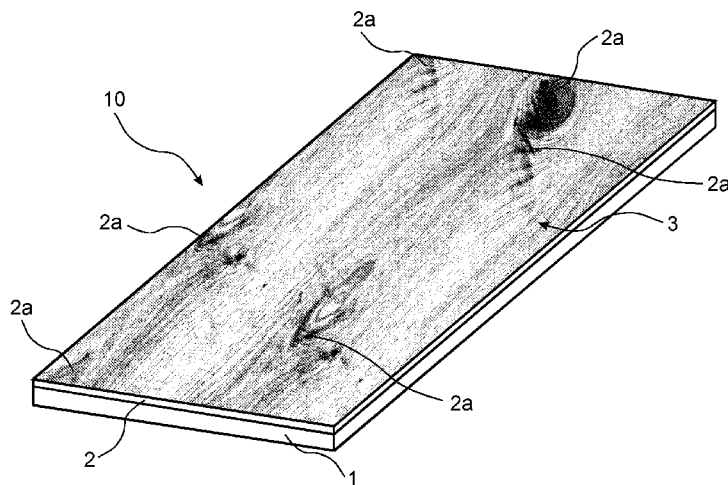

FIG. 2

(57) Abstract: The present disclosure relates to a method of producing a veneered element (10), comprising providing a substrate (1), applying a sub-layer (2) on a surface of the substrate (1), applying a veneer layer (3) on the sub-layer (2), and applying pressure to the veneer layer (3) and/or the substrate (1), such that at least a portion of the sub-layer (2) permeates through the veneer layer (3). The disclosure also relates to such a veneered element (10).



A METHOD OF PRODUCING A VENEERED ELEMENT AND SUCH A VENEERED ELEMENT

Technical Field

The disclosure relates to a method of producing a veneered element and such a veneered element.

5 Technical Background

Floor coverings having a wooden surface may be of several different types. Solid wood flooring is formed of a solid piece of wood in form of a plank. Engineered wood flooring is formed of a surface layer of wood glued to a core. The core may be a lamella core or a wood-based panel such as plywood, MDF or HDF. The wooden
10 surface layer may as an example have a thickness of 2-10 mm.

A wooden floor covering may also be formed by gluing a wood veneer to a core, for example, a wood-based panel such as particleboard, MDF or HDF. Wood veneer is a thin wood layer, for example having a thickness of 0.2-1 mm. A flooring with a separate surface layer glued to a core of for example HDF or plywood is more
15 moisture stable than solid wood floorings.

Compared to solid wood and engineered wood floorings, wood veneer floorings can be produced to a lower cost since only a thin wood layer is used. However, a wood veneer layer cannot be sanded as a solid wood or engineered wood flooring can be.

20 As an alternative to wood floorings, laminate floorings are also available. Direct pressed laminated flooring usually comprises a core of a 6-12 mm fibre board, a 0.2 mm thick upper decorative surface layer of laminate and a 0.1-0.2 mm thick lower balancing layer of laminate, plastic, paper or like material.

A laminate surface conventionally comprise two paper sheets, a 0.1 mm thick
25 printed decorative paper and a transparent 0.05-0.1 mm thick overlay intended to protect the decorative paper from abrasion. The transparent overlay, which is made of α -cellulose fibres, comprises small hard and transparent aluminium oxide particles, which gives the surface layer a high wear resistance.

The printed decorative paper and the overlay are impregnated with
30 melamine resin and laminated to a wood fibre based core under heat and pressure. The two papers have prior to pressing a total thickness of about 0.3 mm and they are after pressing compressed to about 0.2 mm.

A wood veneer may have a lower impact resistance than laminate floorings and the production cost is high, compared to laminate floorings, when high quality veneers are to be used.

5 Recently new "paper free" floor types have been developed with solid surfaces comprising a substantially homogenous powder mix of fibres, binders and wear resistant particles referred to as WFF (Wood Fibre Floor). The mix is applied on a wood-based panel such as MDF or HDF, and subsequently applying heat and pressure to the mix to form a surface layer on the panel. Such a flooring and process are described in WO 2009/065769.

10 WO 2009/065769 also discloses a thin surface layer such as wood veneer layer, which is applied on a sub-layer comprising, for example, cork or wood fibres mixed with a binder. The sub-layer is applied on wood fibre based core.

15 US 2,831,794 discloses a process for manufacturing veneer panels. A green veneer is applied on a mat of resin coated core particles of ligno-cellulose fibrous particles. Adhesive is applied on the veneer to bond the veneer to the fibrous core, and to form a dense surface zone in the fibrous core. The material of the core serves to fill knot holes or open flaws in the veneer. When heat and pressure is applied, the result is the formation of a panel, with the surface layer of the particles filling whatever flaws or holes would otherwise the present in the veneer.

20 US 2,419,614 discloses a coated wood product wherein a plywood is coated by a covering or overlay material consisting of mixtures of sawdust and synthetic resin. The veneer layer is coated by the covering or overlay material such that the veneer is no longer visible. The covering forms the uppermost layer of the product.

25 In the above description, the different types of product have been described with reference to floorings. However, the same material and problems applies for other types of building panels such as wall panels, ceiling panels, and for furniture components.

Summary

30 It is an object of at least embodiments of the present invention to provide an improvement over the above described techniques and known art.

A further object of at least embodiments of the present invention is to improve properties of a veneer surface.

35 A further object of at least embodiments of the present invention is to improve the wear resistance of a veneer surface.

A further object of at least embodiments of the present invention is to reduce the cost for producing surface with an attractive design.

A further object of at least embodiments of the present invention is to use veneers of low quality and/or thin thickness.

A further object of at least embodiments of the present invention is to provide a wood veneer surface having the look of a solid wood surface.

5 A further object of at least embodiments of the present invention is to provide a veneer surface having an attractive design.

A further object of at least embodiments of the present invention is to control the design of a veneer surface.

10 A further object of at least embodiments of the present invention is to improve water resistance of a veneer surface.

At least some of these and other objects and advantages that will be apparent from the description have been achieved by a method of producing a veneered element, comprising

- providing a substrate,
- 15 - applying a sub-layer on a first surface of the substrate,
- applying a veneer layer on the sub-layer, and
- applying pressure to the veneer layer and/or the substrate, such that at least a portion of the sub-layer permeates through the veneer layer.

20 Said at least a portion of the sub-layer may permeate at least partly through the veneer layer, or may permeate completely through the veneer layer.

Preferably, the method may further comprise applying a protective layer comprising a thermoplastic material on the veneer layer. The protective layer may be applied on the veneer layer prior or after the step of applying pressure to the veneer layer and/or the substrate. If the protective layer is applied on the veneer
25 layer prior to applying pressure, pressure is applied to the veneer layer via the protective layer. In one embodiment, the protective layer is applied on the veneer layer after the step of pressing, and is attached to the veneer layer in an additional step, for example, by pressing.

30 An advantage of at least certain embodiments is that the protective layer comprising the thermoplastic material protects the veneer layer. By arranging a protective layer comprising thermoplastic material on the veneer layer, a substrate having a veneer surface layer being waterproof may be obtained. The protective layer contributes with water resistant properties to the veneer layer, such that a waterproof surface layer is obtained, wherein the decorative properties of the
35 substrate are formed by the veneer layer.

Furthermore, the gloss level of the protective layer may be determined by the press plate or press belt when pressing the protective layer to the veneer layer.

The protective layer is preferably transparent, or at least substantially transparent.

5 The method may further comprise applying the protective layer to at least a portion of an edge surface of the substrate, for example, a bevel formed along an edge of the substrate. Thereby, also an edge portion of the substrate is protected by the protective layer such that the water resistance of the veneered element is further improved.

10 The thermoplastic material may comprise polyvinyl chloride (PVC), polyester, polypropylene (PP), polyethylene (PE), polystyrene (PS), polyurethane (PU), polyethylene terephthalate (PET), polyacrylate, methacrylate, polycarbonate, polyvinyl butyral, polybutylene terephthalate, or a combination thereof. The protective layer may comprise more than one thermoplastic material.

15 The protective layer may comprise one or more layers, wherein the layer may comprise different thermoplastic materials, or thermoplastic material of the same type.

The protective layer may be at least one thermoplastic foil.

20 The protective layer may further comprise wear resistant particles. The wear resistant particles may be applied between a first and a second layer of the protective layer. Alternatively, the wear resistant particles may be applied on the veneer layer prior to applying the protective layer. At least some of the wear resistant particles will protrude from upper portions of the protective layer, or be arranged in the upper portions of the protective layer, after pressing. Thereby, the wear resistant particles provide wear resistance to the protective layer.

25 The step of applying the protective layer may comprise applying the thermoplastic material in powder form on the veneer layer. The thermoplastic material in powder form may be mixed with wear resistant particles.

30 The step of applying the protective layer may comprise applying a first foil comprising a first thermoplastic material, on the veneer layer, and applying a second foil comprising a second thermoplastic material on the first foil, wherein the first thermoplastic material is different from the second thermoplastic material.

35 The first and second thermoplastic material may be any of polyvinyl chloride (PVC), polyester, polypropylene (PP), polyethylene (PE), polystyrene (PS), polyurethane (PU), polyethylene terephthalate (PET), polyacrylate, methacrylate, polycarbonate, polyvinyl butyral, polybutylene terephthalate, or a combination thereof.

In one embodiment, the first thermoplastic material is polyvinyl chloride (PVC). The second thermoplastic material may be polyurethane (PU). Compared to a

conventional protective layer substantially consisting of polyvinyl chloride, a protective layer comprising an upper portion of polyurethane obtains improved chemical resistance. Its scuff resistance and micro scratch resistance are also improved. An upper layer of polyurethane also provides improved resistance against black heel mark.

The method may further comprise controlling a design of the veneer layer by controlling permeation of the sub-layer through the veneer layer. Preferably, controlling a design of the veneer layer is performed by determining a level of permeation of the sub-layer through the veneer layer. Determining a level of permeation may involve selecting or adjusting the permeation. This may involve selecting or adjusting a fluid pressure of the sub-layer when applying pressure.

By controlling is meant determining, selecting and/or adjusting.

By determining is, for example, meant determining by visual impression of the design of the veneer layer.

Preferably, at least a portion of the sub-layer is visible at the surface of the veneer layer facing away from the substrate.

The substrate is preferably a pre-fabricated substrate. Preferably, the substrate is manufactured in a preceding manufacturing process.

An advantage of at least certain embodiments is that the surface design of the veneered element may be changed or altered by a portion of the sub-layer permeating through the veneer. By applying pressure to the veneer layer and/or the substrate, a part of the sub-layer flows through pores, or cracks or holes, of the veneer such that a part of the sub-layer becomes visible at the surface of the veneer facing away from the substrate. Thereby, the design of the veneer is changed, especially if the sub-layer comprises pigments. A new design can be created, or features of the veneer such as cracks and knots can be intensified by the sub-layer being visible at the surface of the veneer.

The veneer layer forms the visible surface of the veneered element. The design of the veneer layer, permeated by at least a portion of the sub-layer, forms the design of the veneered element.

The veneer layer may also be reinforced by being arranged on the sub-layer. Further, the veneer layer may obtain improved wear resistant properties by being at least partly impregnated by the sub-layer. The sub-layer arranged under the veneer layer may also improve impact resistance properties of the veneer. The sub-layer may comprise a binder or lacquer giving the veneer improved wear resistant properties. The sub-layer may also comprise wear resistant particles.

Since the sub-layer also flows into the substrate during pressing, the sub-layer provides improved impact, surface soundness, adhesive capacity, reduced swelling, etc.

5 A further advantage of at least certain embodiments is that water resistance of the veneer layer is improved. During pressing, the veneer layer is compressed. Furthermore, during pressing, the binder flows into pores into the veneer and if a thermosetting binder is used, cures and the veneer layer is at least partially locked in this compressed state due to the cured binder holding the veneer layer in this position. Thereby, pores of the veneer layer are at least partially filled with the
10 binder such that water resistance of the veneered element is improved.

Furthermore, an advantage of at least certain embodiments is that the sub-layer may fill any cracks, holes, or knots of the veneer layer. Thereby, there is no need, or at least a reduced need, to putty cracks, holes or knots of the veneer layer. Thereby, a costly operation often made by hand is eliminated or at least reduced by
15 arranging the veneer layer on a sub-layer when pressing the veneer to the substrate.

By arranging the veneer on the sub-layer, and by at least a part of the sub-layer flowing through the veneer such that cracks, cavities or knots are filled by the sub-layer, a thinner veneer may be used, or a veneer of lower quality may be used, for example, containing more irregularities and defects.

20 Furthermore, by including pigments in the sub-layer, the veneer may be coloured. A glazing effect, a lazuring effect and/or staining effect may be obtained.

By including additives to the sub-layer, the properties of the veneer layer may be changed. For example, sound-absorbing fillers, such as cork particles, may be added to the sub-layer to improve the sound absorbing properties of the veneered
25 element. Anti-static agents may be added to the sub-layer. Additives improving the heat transfer of the veneered element may also be added.

In an embodiment wherein the substrate is a core, the core and the veneered element being bonded to the core form a building panel or a furniture component. The building panel may be a floor panel, a ceiling panel, a wall panel, a door panel, a
30 worktop, skirting boards, mouldings, edging profiles, etc.

In an embodiment, the veneered element is formed as a separate element, which later may be adhered to a component. The substrate may be a carrier for the veneer layer and the sub-layer, or may be a temporary carrier from which the veneer layer and the sub-layer later are removed.

35 The method may further comprise controlling permeation of the sub-layer through the veneer layer. By controlling is meant, here and in the following, determining, selecting and/or adjusting. Thereby, the design and appearance of the

surface may be varied and controlled by varying and controlling fluid pressure, binder concentration, type of binder, filler concentration, veneer properties, etc. By controlling these parameters, the amount of the sub-layer which permeates the veneer layer can be controlled, and thereby the design of the veneer layer can be
5 changed in a controlled manner.

The method may further comprise processing the veneer layer by abrasive machining prior to applying pressure to the veneer layer and/or the substrate. The method may further comprise brushing the veneer layer prior to applying pressure to the veneer layer and/or the substrate. By abrasive machining the veneer layer,
10 material from the veneer layer is mechanically removed.

In one embodiment, controlling permeation of the sub-layer through the veneer layer may comprise abrasive machining the veneer layer prior to applying pressure to the veneer layer and/or the substrate.

In one embodiment, controlling permeation of the sub-layer through the veneer layer may comprise brushing the veneer layer prior to applying pressure to
15 the veneer layer and/or the substrate.

By abrasive machining and/or brushing the veneer layer, holes, cavities and/or cracks are formed in the veneer layer. Abrasive machining and/or brushing the veneer layer may enlarge existing holes, cavities and/or cracks, and/or form new
20 holes, cavities and/or cracks. By forming, or enlarging existing, holes, cavities, and cracks, the sub-layer permeates more easily through the veneer layer. Thereby, the permeation of the sub-layer through the veneer layer is increased, and the design of the veneer layer can be controlled and changed.

The veneer layer may be brushed prior to being applied on the sub-layer, or
25 when being applied on the sub-layer. The same applies to abrasive machining and/or processing of the veneer layer.

Abrasive machining of the veneer layer may be performed by an abrasive tool. The abrasive tool may be a brushing device. The abrasive tool may be brush filaments, abrasive strips, sanding belts, sanding disks, grinding wheels, cutting tools
30 such as water jet, etc.

The veneer layer may be processed by an abrasive tool such that veneer material with low density is removed while veneer material with higher density remains. The abrasive tool may be harder than at least portions of the veneer layer.

Both surfaces, or only one of the surfaces, of the veneer layer, may be
35 machined abrasively. A lower surface of the veneer layer adapted to face the sub-layer may be machined. An upper surface of the veneer layer adapted to facing upwards may be machined. By machining abrasively the upper surface of the veneer

layer, flowing of the sub-layer in a direction parallel to the surface of the veneer layer is increased. By machining abrasively the lower surface of the veneer layer, the sub-layer may fill cavities formed in the lower surface of the veneer layer.

5 Machining abrasively may be performed at different levels in the veneer layer. Cavities, holes and/or cracks may be extending through the veneer layer, or may extend partly through the veneer layer. The depth of the cavities, holes and/or cavities may substantially equal the thickness of the veneer layer, or may be less than the thickness of the veneer layer.

10 Machining the veneer layer prior to applying pressure may also be combined with machining performed after pressure has been applied to form the veneered element.

 The abrasive machining and/or processing of the veneer layer may, for example, include brushing, sanding, grinding, blasting, local compressing, tearing, splitting, compressed air, etc.

15 Controlling permeation of the sub-layer through the veneer layer may comprise processing the veneer layer prior to applying pressure to the veneer layer and/or the substrate. Such processing may include heating, for example, by thermal radiation, convective heating, and/or conductive heating, steaming, and/or drying veneer prior to applying pressure to the veneer layer and/or the substrate.

20 Permeation may also be controlled by applying additives to the veneer layer adjusting the permeation of the sub-layer through the veneer layer. As an example, an additive reducing permeation of the sub-layer through the veneer layer, for example, by blocking permeation, may be applied. Alternatively or in combination, an additive degrading the veneer layer, thus increasing permeation may also be
25 applied on the veneer layer.

 Controlling permeation of the sub-layer through the veneer layer may comprise compressing the veneer prior to applying the veneer on the sub-layer. By compressing the veneer, the density of at least portions of the veneer is increased, thus reducing permeation of the sub-layer through at least portions of the veneer
30 layer during pressing. Compressing may be performed by pressing plates and/or rollers with embossings. The compression, preferably combined with heating, preferably heating to a temperature exceeding 100°C, may result in a remaining increase in density.

35 Controlling permeation of the sub-layer through the veneer layer may comprise controlling a fluid pressure of the sub-layer during pressing. A fluid pressure of the sub-layer is formed by applying pressure to the veneer layer and/ or the substrate. In one embodiment, the sub-layer may be in fluid form when applied

on the substrate, or may be transformed into fluid form by applying heat and pressure, such as the case for a thermosetting binder applied in powder form. By increasing the fluid pressure, a larger amount of the sub-layer permeates through the veneer layer, and/or longer way through the veneer layer, and/or permeates
5 into the veneer layer in a direction parallel to a plane of the veneer layer, such that larger spots of the sub-layer are visible from the surface of the veneer layer. Furthermore, when the sub-layer includes a thermosetting binder, the cross-linking reaction results in forming of condensation water, transforming into steam under the applied heat and pressure, thereby increasing the fluid pressure. The cross-
10 linking also results in solidification of a part of the sub-layer, thus further pressing remaining uncured binder of the sub-layer.

Controlling the fluid pressure of the sub-layer may comprise adjusting a concentration of a binder in the sub-layer. By increasing the concentration of the binder in the sub-layer, the part of the sub-layer that flows when heat and pressure
15 are applied increases, and thereby a larger part of the sub-layer may permeate through the veneer layer. When the binder flows, the binder brings any pigments to upper parts of the veneer.

Controlling the fluid pressure of the sub-layer may comprise adjusting the type of binder used in the sub-layer. Different binders have different properties, such as
20 how fast the binder cures and hardens. When using a binder that cures rapidly, less permeation of the sub-layer occurs compared to a binder that cures more slowly, thus being in liquid form over a longer time and allowing permeation through the veneer layer.

Controlling the fluid pressure of the sub-layer may comprise adjusting the
25 formulation of the binder of the sub-layer, such that properties of the sub-layer is controlled and adjusted.

The design of the veneered element may also be performed by controlling a ratio between pigment and binder of the sub-layer. By adjusting the binder
30 concentration, and the ratio pigment/binder, the amount of pigment permeating through the veneer layer can be controlled. The binder brings the pigments when the binder flows during pressing. The amount of pigment that permeates through the veneer layer may also be controlled and adjust by choosing the size of the pigment particles. Smaller pigment particles permeate more easily through the veneer layer than larger pigment particles.

35 Controlling the fluid pressure may comprise adjusting the moisture content of the sub-layer. By increasing the moisture content of the sub-layer, more steam is formed when heat and pressure is applied, which forms an increased fluid pressure

and thereby increased permeation of the sub-layer through the veneer layer.

Contrary, if less permeation is desired, the moisture content of the sub-layer may be decreased, for example by drying before pressing.

Controlling the fluid pressure may comprise adjusting the pressure applied to
5 the veneer layer and/or the substrate. By increasing the pressure, the fluid pressure of the sub-layer is increased. By increasing the fluid pressure, a larger amount of the sub-layer permeates through the veneer layer as described above.

Controlling the fluid pressure may comprise generating a gas pressure in the
10 sub-layer. The gas pressure increases the fluid pressure of the sub-layer, thus resulting in that the sub-layer permeates through the sub-layer in an increased extent.

Generating the gas pressure may comprise including chemical and/or
physical blowing agents in the sub-layer. When reacting, the chemical and/or
physical blowing agents form a gas pressure in the sub-layer.

Controlling permeation of the sub-layer through the veneer layer may
15 comprise including fillers in the sub-layer. By increasing the amount of fillers in the sub-layer, the less the sub-layer permeates through the veneer layer. The fillers may reduce flowing of the sub-layer such that the sub-layer permeates more difficult through the veneer layer. Furthermore, some fillers, for example, wood particles,
20 absorb the binder to a certain degree, thereby reducing the amount of free binder, which may permeate through veneer layer, and thereby also reduce the fluid pressure. The fillers may comprise wood particles such as lignocellulosic and/or
cellulosic particles. The wood particles may be at least partially bleached.

Controlling the permeation of the sub-layer through the veneer layer may
25 comprise adjusting the thickness of the sub-layer, for example by adjusting the amount of the sub-layer applied. If the sub-layer is applied as a powder, controlling the permeation of the sub-layer through veneer layer may be controlled by adjusting the amount of powder applied for forming the sub-layer. By applying a larger
amount of powder for forming the sub-layer, the sub-layer permeates through the
30 veneer layer to an increased extent.

Controlling permeation of the sub-layer through the veneer layer may
comprise forming holes and/or cracks in the veneer layer. The holes and/or cracks
facilitate the sub-layer to permeate through the veneer layer. Forming holes and
cracks reduces resistance for the sub-layer for permeating through the veneer layer.
35 Forming holes, cavities and/or cracks may be performed by brushing prior to
applying pressure to the veneer layer and/or the substrate. The holes, cracks and

cavities may be pre-existing but enlarged, and/or may be newly formed holes, cracks and cavities.

Controlling permeation of the sub-layer through the veneer layer may comprise controlling a thickness of the veneer layer. The thinner veneer layer, the
5 less distance for the sub-layer to travel until the sub-layer is visible on the top surface of the veneer layer.

Said at least a portion of the sub-layer may permeate through pores of the veneer layer. A veneer is a porous structure, including pores in which the sub-layer may permeate.

10 Said at least a portion of the sub-layer may permeate through cracks and holes of the veneer layer.

After pressing, the veneer layer may be mechanically/and or chemically treated such that a desired appearance of the veneered element is obtained. For examples, the veneer layer may be brushed and/or sanded after pressing.

15 The veneer layer may comprise a wood veneer, a cork veneer, or stone veneer. The veneer layer has a porous structure, and a portion of sub-layer may permeate through the veneer layer. The wood veneer may be cut veneer, sawn veneer, rotary cut veneer, and/or half-round cut veneer.

The sub-layer may comprise a binder.

20 The sub-layer may comprise a thermosetting binder. The thermosetting binder may be an amino resin such as melamine formaldehyde, urea formaldehyde, phenol formaldehyde, or a combination thereof. The thermosetting binder simultaneously bonds the veneer layer to the sub-layer. When heat and pressure is applied to the sub-layer, the thermosetting binder becomes fluid before cross-
25 linking takes place. The applied heat and pressure results in curing of the thermosetting binder of the sub-layer, simultaneously as bonding the veneer layer to the sub-layer.

The sub-layer may comprise a thermoplastic binder. The thermoplastic binder may be polyvinyl chloride (PVC), polyethylene (PE), polypropylene (PP),
30 polyurethane (PU), polyvinyl alcohol (PVOH), polyvinyl butyral (PVB), and/or polyvinyl acetate (PVAc), or a combination thereof. The thermoplastic binder simultaneously bonds the veneer layer to the sub-layer.

The sub-layer may be substantially formaldehyde free.

35 The sub-layer may further comprise pigments. Thereby, the veneer layer may be coloured by the parts of the sub-layer penetrating through the veneer layer. The sub-layer may be pigmented to one or several different colours. By using a sub-layer containing different colours, different parts of the veneer layer and/or different

veneers may obtain different colours. The pigments may be brought by the flowable binder to an upper part of the veneer layer. The pigments may provide a colour being darker or lighter than the natural colour of the veneer. The pigment may be white, such as TiO₂. White pigments, such as TiO₂, may be combined with at least partially bleached wood particles, for example, to form a pale staining of the veneer.

The sub-layer may comprise wear resistant particles. Wear resistant particles which are brought by the binder of the sub-layer to an upper part of the veneer layer provide wear resistance to the veneer layer.

The substrate may be a wood-based board, for example, a wood-fibre based board such as MDF or HDF, or plywood. The substrate may be a Wood Plastic Composite (WPC). The substrate may be a mineral composite board. The substrate may be a fibre cement board. The substrate may be magnesium oxide cement board. The substrate may be a ceramic board. The substrate may be a plastic board such as a thermoplastic board.

The substrate may be a sheet such as paper sheet.

The fluid pressure may be uniformly distributed. Thereby, an essentially uniform permeation of the sub-layer through the veneer layer may be obtained, if the veneer layer has an essentially uniform structure. An essentially uniform colouring of the veneer layer may also be obtained, if the veneer layer has an essentially uniform structure.

The fluid pressure may be non-uniformly distributed. By the fluid pressure being non-uniformly distributed, the degree of permeation of the sub-layer may vary of the surface of the veneer and non-uniform pattern may be obtained.

The method may further comprise digital printing a pattern in the sub-layer prior to applying the veneer layer on the sub-layer. The method may further comprise digital printing a pattern on the veneer layer, prior or after pressing.

The veneer layer may be a continuous layer or a discontinuous layer of veneers. The veneer layer may be formed of several veneers pieces. The veneer layer may be formed of several pieces of veneer, forming a patchwork of veneers. The sub-layer may fill the gaps between the veneer pieces.

After pressure has been applied, the veneer layer may comprise embossed portions. A portion of the sub-layer may be more compressed under an embossed portion than under a non-embossed veneer layer portion.

The embossed portions may be naturally occurring after pressing. For wood veneers having a porous structure, such as hard wood (e.g., angiosperm), porous portions of the veneer form embossed portions after pressing, since these portions do not spring back from their compressed state when the pressure is released.

These porous portions are filled with the binder of the sub-layer during pressing. Then the binder cures and/or hardens, the binder locks the position of the porous portions in the compressed state. The portions of veneer having high density, i.e. being non-porous, are compressed during pressing but spring back when the pressure is released, thus forming protrusions of the surface layer. The high-density portions do not absorb enough binder from the sub-layer to be locked by the hardened binder after pressing.

For wood veneer having a non-porous structure, such as soft wood (e.g., gymnosperm), the summer wood annual rings (also called late wood annual rings), having high density, are not compressible during pressing. Instead, the summer wood annual rings are pressed into the sub-layer such that the sub-layer is compressed. The summer wood annual rings form embossed portions of the surface layer. The spring wood annual rings (also called early wood annual rings) are compressible during pressing. During pressing, the spring wood annual rings are compressed. Then the pressure is released, the spring wood annual rings spring back, and form protrusions.

The embossed portions of the surface layer may also be formed by pressing by an embossed pressing device, such as an embossed press plate.

The method may further comprise applying a balancing layer on a surface of the substrate being opposite the veneer layer. The balancing layer may be a powder based balancing layer being applied as a powder. The powder based balancing layer may comprise wood particles such as lignocellulosic and/or cellulosic particles and a binder, preferably a thermosetting binder such as an amino resin. The balancing layer may be a resin impregnated paper, preferably impregnated with a thermosetting binder.

According to a second aspect of the invention, the present invention is realised by a veneered element. The veneered element comprises a substrate, a sub-layer arranged on the substrate, and a veneer layer arranged on the sub-layer, and wherein at least a portion of the sub-layer is permeated through the veneer layer.

At least a portion of the sub-layer may be visible at the surface of the veneer facing away from the substrate.

Preferably, a protective layer comprising thermoplastic material is arranged on the veneer layer.

An advantage of at least certain embodiments is that the protective layer comprising the thermoplastic material protects the veneer layer. By arranging a protective layer comprising thermoplastic material on the veneer layer, a substrate

having a veneer surface layer being waterproof may be obtained. The protective layer contributes with water resistant properties to the veneer layer, such that a waterproof surface layer is obtained, wherein the decorative properties are formed by the veneer layer.

5 Furthermore, the gloss level of the protective layer may be determined by the press plate when pressing the protective layer to the veneer layer.

 The protective layer is preferably transparent, or at least substantially transparent.

 The protective layer may comprise at least one thermoplastic foil.

10 The thermoplastic material may comprise polyvinyl chloride (PVC), polyester, polypropylene (PP), polyethylene (PE), polystyrene (PS), polyurethane (PU), polyethylene terephthalate (PET), polyacrylate, methacrylate, polycarbonate, polyvinyl butyral, polybutylene terephthalate, or a combination thereof. The protective layer may comprise more than one thermoplastic material.

15 The protective layer may comprise one or more layers, wherein the layer may comprise different thermoplastic materials, or thermoplastic material of the same type.

 The protective layer may further comprise wear resistant particles. The wear resistant particles may be arranged between a first and a second layer of the
20 protective layer. Alternatively, the wear resistant particles may be arranged on the veneer layer below the protective layer. At least some of the wear resistant particles will protrude from upper portions of the protective layer, or be arranged in the upper portions of the protective layer, after pressing. Thereby, the wear resistant particles provide wear resistance to the protective layer.

25 The protective layer may formed of the thermoplastic material in powder be mixed with wear resistant particles.

 The first and second thermoplastic material may be any of polyvinyl chloride (PVC), polyester, polypropylene (PP), polyethylene (PE), polystyrene (PS),
30 polyurethane (PU), polyethylene terephthalate (PET), polyacrylate, methacrylate, polycarbonate, polyvinyl butyral, polybutylene terephthalate, or a combination thereof.

 In one embodiment, the first thermoplastic material is polyvinyl chloride (PVC). The second thermoplastic material may be polyurethane (PU). Compared to a
35 conventional protective layer substantially consisting of polyvinyl chloride, a protective layer comprising an upper portion of polyurethane obtains improved chemical resistance. Its scuff resistance and micro scratch resistance are also

improved. An upper layer of PU also provides improved resistance against black heel mark.

The sub-layer may further comprise pigments.

5 The sub-layer may comprise fillers. The fillers may be particles or fibres, for example wood fibres or particles, or mineral particles or fibres. The wood particles may be lignocellulosic particles and/or cellulosic particles. The wood particles may be at least partially bleached.

The sub-layer may comprise wear resistant particles.

10 The substrate may be a wood-based board, for example, a wood-fibre based board such as MDF or HDF, or plywood. The substrate may be a Wood Plastic Composite (WPC). The substrate may be a mineral composite board. The substrate may be a fibre cement board. The substrate may be magnesium oxide cement board. The substrate may be a ceramic board. The substrate may be a plastic board such as a thermoplastic board.

15 The at least a portion of the sub-layer may be permeated through pores of the veneer layer.

The veneer layer may comprise a wood veneer, a cork veneer, or a stone veneer.

20 The veneer layer may comprise embossed portions. A portion of the sub-layer may be more compressed under an embossed portion than under a non-embossed veneer layer portion.

25 The embossed portions may be naturally occurring after pressing. For wood veneers having a porous structure, such as hard wood (e.g., angiosperm), porous portions of the veneer form embossed portions after pressing, since these portions do not spring back from their compressed state when the pressure is released. These porous portions are filled with the binder of the sub-layer during pressing. Then the binder cures and/or hardens, the binder locks the position of the porous portions in the compressed state. The portions of veneer having high density, i.e. being non-porous, are compressed during pressing but spring back when the
30 pressure is released, thus forming protrusions of the surface layer. The high-density portions do not absorb enough binder from the sub-layer to be locked by the hardened binder after pressing.

35 For wood veneer having a non-porous structure, such as soft wood (e.g., gymnosperm), the summer wood annual rings (also called late wood annual rings), having high density, are not compressible during pressing. Instead, the summer wood annual rings are pressed into the sub-layer such that the sub-layer is compressed. The summer wood annual rings form embossed portions of the surface

layer. The spring wood annual rings (also called early wood annual rings) are compressible during pressing. During pressing, the spring wood annual rings are compressed. Then the pressure is released, the spring wood annual rings spring back, and form protrusions.

5 The embossed portions of the surface layer may also be formed by pressing by an embossed pressing device, such as an embossed press plate.

 The method may further comprise applying a balancing layer on a surface of the substrate being opposite the veneer layer. The balancing layer may be a powder based balancing layer being applied as a powder. The powder based balancing layer
10 may comprise wood particles such as lignocellulosic and/or cellulosic particles and a binder, preferably a thermosetting binder such as an amino resin. The balancing layer may be a resin impregnated paper, preferably impregnated with a thermosetting binder.

 The veneered element according to the second aspect of the present
15 invention incorporates all the advantages of the method, which previously has been discussed, whereby the previous discussion is applicable also for the veneered element.

 According to a third aspect of the invention, a method of producing an element is provided. The method comprises
20 - providing a substrate,
 - applying a sub-layer on a first surface of the substrate,
 - applying a surface layer having a porous structure on the sub-layer, and
 - applying pressure to the surface layer and/or the substrate, such that a
 least a portion of the sub-layer is permeating through the porous structure of the
25 surface layer.

Brief Description of the Drawings

 The present invention will by way of example be described in more detail with reference to the appended schematic drawings, which show embodiments of
30 the present invention.

 Figs. 1a-c illustrates embodiments of a method of a producing a veneered element according to embodiments.

 Fig. 2 illustrates an embodiment of a veneered element.

 Fig. 3 illustrates a cross-section of a veneered element.

35 Fig. 4 illustrates an embodiment of a veneered element.

 Fig. 5 illustrates an embodiment of a veneered element.

Detailed Description

Figs. 1a-c show embodiments of a method of producing a veneered element 10. The veneered element 10 may be a furniture component, a building panel such as a floor panel, a ceiling panel, a wall panel, a door panel, a worktop, skirting boards, mouldings, edging profiles, etc. The method comprises providing a substrate 1. The substrate is preferably a pre-fabricated substrate, manufactured prior to the method of producing the veneered element 10. The substrate 1 may be a board, for example, a wood-based board as shown in the embodiment shown in figs. 1-4. The wood-based board may be a wood fibre based board such as MDF, HDF, particleboard etc., or a plywood board. In other embodiments, the substrate may be a Wood Plastic Composite (WPC). The substrate may be a mineral composite board. The substrate may be a fibre cement board. The substrate may be magnesium oxide cement board. The substrate may be a ceramic board. The substrate may be a plastic board such as a thermoplastic board. In another embodiment, the substrate 1 may be a carrier such as sheet of paper or non-woven as shown in fig. 5, or a conveyor.

A sub-layer 2 is applied on a first surface 4 of the substrate 1. In the embodiment shown in fig. 1a, the sub-layer 2 is applied in powder form 21. The powder 21 adapted to form the sub-layer 2 is applied by scattering, as shown in fig. 1a. The sub-layer may also be applied as granules. In other embodiments, the sub-layer 2 may be applied as a liquid, as a paste, a sheet, etc. The sub-layer 2 may be applied by roller coating, spraying, etc.

In one embodiment, the sub-layer 2 comprises a sheet impregnated with a thermosetting binder. The sheet may be paper sheet. The sheet may be coloured, and/or the binder solution used to impregnate the sheet may be coloured, such that sheet becomes coloured during impregnation.

The sub-layer 2 comprises a binder. The binder may be a thermosetting binder, a thermoplastic binder, or a combination thereof. The binder may be wood mastic, wood filler or any other type of putty-like paste. The thermosetting binder may be an amino resin such as melamine formaldehyde resin, phenol formaldehyde resin, urea formaldehyde resin, or a combination thereof. Urea formaldehyde resin may be used, alone or in combination with melamine formaldehyde resin, to reduce tension formed by the sub-layer 2 during curing, compared to when melamine formaldehyde resin is used only. The thermoplastic binder may be polyvinyl chloride (PVC), polyethylene (PE), polypropylene (PP), polyurethane (PU), polyvinyl alcohol (PVOH), polyvinyl butyral (PVB), polyvinyl acetate (PVAc), and/or thermoplastic elastomer (TPE), or a combination thereof.

The binder may be in powder form when applied.

The sub-layer 2 may be formed of a mix comprises a binder of the above described type and fillers. The mix may further comprise pigments. The mix may further comprise additives. The mix may further comprise wear and/or scratch
5 resistant particles. As an alternative to a mix, the binder, fillers, pigments, additives and any other component may be applied separately on the substrate 1.

The fillers may be particles or fibres, for example wood fibres or particles, or mineral particles or fibres. The wood particles may be lignocellulosic particles and/or
10 cellulosic particles. The wood particles may be at least partially bleached. The fillers may be rice, straw, corn, jute, linen, flax, cotton, hemp, bamboo, bagasse or sisal particles or fibres. The sub-layer may comprise starch such as maize starch, potato starch, etc.

The fillers may be fillers having sound-absorbing properties such as cork particles and/or barium sulphate (BaSO_4). Alternatively, a sound-absorbing layer, for
15 example a cork layer or cork veneer layer, may be arranged as an intermediate layer. The sub-layer is applied on the sound-absorbing layer. The sound-absorbing layer may be arranged on the substrate, or on a sub-layer arranged on the substrate.

The pigments may be darker than the natural colour of the veneer layer, and/or be paler than the natural colour of the veneer layer. The pigments may
20 include white pigments such as TiO_2 . A pigment such as TiO_2 can be combined with at least partially bleached wood particles to obtain a white staining of the veneer by the permeation of the sub-layer through the veneer. In one embodiment, a pre-mix is formed by white pigments such as TiO_2 and wood particles, preferably at least partially bleached wood particles. The pre-mix is then mixed with remaining wood
25 particles, binder, additives etc.

The additives may be wetting agents, anti-static agents such as carbon black, and heat-conducting additives such as aluminium. Other possible additives are magnetic substances.

The sub-layer 2 may also comprise a foil or a sheet.

30 Additives such as blowing agents may be included in the sub-layer. The blowing agents may be physical foaming agents such as EXPANCEL(RTM) and/or chemical blowing agents such as AIBN (azoisobutyronitrile) or ADC (azodicarbonamide).

The wear and/or scratch resistant particles may be aluminium oxide particles
35 and/or silica particles.

In one embodiment, the sub-layer 2 consists essentially of the binder and optionally additives, meaning that at least 90% of the sub-layer 2 is the binder and

optional additive(s). In one embodiment, the sub-layer 2 is free from any fibres and/or fillers.

The sub-layer 2 may be applied in an amount of 200-600 g/m², preferably 300-500 g/m² such as about 400 g/m². The amount of binder applied for the sub-layer 2 may be 100-300 g/m², preferably 150-250 g/m² such as about 200 g/m². The sub-layer 2 may comprise the binder in an amount of 30-80 wt%, preferably in an amount of 40-60 wt% such as about 50 wt%.

The sub-layer 2 may be pre-pressed prior to applying the veneer layer 3.

A veneer layer 3 is applied on the sub-layer 2. The veneer layer 3 may be a wood veneer, a cork veneer, or a stone veneer. The veneer has a porous structure, thus being permeable. The veneer layer 3 may have a thickness of about 0.2 to 1 mm. The veneer layer 3 may be continuous or non-continuous. The veneer layer 3 may be formed of several veneer pieces. The veneer pieces may be over-lapping or non-overlapping. A gap may be formed between the veneer pieces. The gap may be filled by the sub-layer 2 after pressing. The veneer pieces may be applied randomly or forming a pattern. A patchwork of veneer pieces may be formed. The veneer pieces may be arranged in a pattern such as a herringbone pattern, Dutch pattern etc., with several veneer pieces arranged on one substrate 1. The veneer pieces may also be arranged such that the veneer pieces, or the gap between the veneer pieces, form a template.

The sub-layer 2 may have a uniform colour, different shades, or different portions of the sub-layer may have different colours. A multi-coloured veneer layer 3 may be formed by colouring different portions of the sub-layer 2 in different colours. If the veneer layer 3 is formed by several veneer pieces, a first set of veneer pieces may be differently coloured than a second set of veneer pieces. Alternatively, each veneer piece may be differently coloured by the sub-layer being differently coloured under each veneer piece.

In one embodiment, a digital print may be printed in the sub-layer 2, preferably by an ink jet printer. The different colours of the print permeate through the veneer layer 3 such that the colouring of the sub-layer 2 is transferred into the surface of the veneer layer 3. The colouring and/or pattern of the sub-layer 2 may also be obtained by a binder and print technique (BAP), for example as described in WO2014/017972. In one embodiment, a digital print is printed on the veneer layer 3.

More than one veneer layer 3 may be arranged on a core. In one embodiment, a first veneer layer may be arranged on the substrate 1, a sub-layer 2 of the above described type is arranged on the first veneer layer, and a second

veneer layer is arranged on the sub-layer 2. A groove may be formed, for example after pressing, in the second veneer layer and in the sub-layer 2 such as the first veneer layer is visible. A gap may also be arranged between different portions of the second veneer layer such that the sub-layer and/or the first veneer layer is visible.

5 The veneer layer may also comprise veneer pieces arranged crosswise.

In the embodiment shown in fig. 1b, a protective layer 11 is arranged on the veneer layer 3. The protective layer 11 comprises a thermoplastic material. After the protective layer 11 has been arranged on the veneer layer 3, pressure is applied to the veneer layer 3, via the protective layer 11, and/or the substrate 1 such that a
10 fluid pressure is formed in the sub-layer 2. The pressure may be applied by continuous press 30 or in a discontinuous press (not shown). Preferably, heat is also applied. The gloss level of the protective layer may be determined and changed by the press plate or press belt when pressing the protective layer to the veneer layer. Different gloss levels may be obtained by a pressing device having different gloss.
15 The pressing device may also comprise embossed portion such that a structured protective layer 11 is obtained.

In the embodiment shown in fig. 1c, pressure is applied to the veneer layer 3 and/or the substrate 1 such that a fluid pressure is formed in the sub-layer 2. The pressure may be applied by continuous press 30 or in a discontinuous press (not
20 shown). Preferably, heat is also applied. In a subsequent step, a protective layer 11 is applied to the veneer layer 3. The protective layer 11 comprises a thermoplastic material. The protective layer 11 may be attached to the veneer layer 3 by any conventional means, such as pressing, gluing etc. In the embodiment shown in fig. 1c, pressure is applied to the protective layer 11 and/or the substrate 1 in a
25 continuous press 31 for attaching the protective layer 11 to the veneer layer 3. The pressure may also be applied in a static press (not shown). The gloss level of the protective layer may be determined and changed by the press plate or press belt when pressing the protective layer to the veneer layer. Different gloss levels may be obtained by a pressing device having different gloss. The pressing device may also
30 comprise embossed portion such that a structured protective layer 11 is obtained.

The protective layer may also be attached to at least a portion of an edge surface of the substrate, for example, a bevel formed along an edge of the substrate. Thereby, also an edge portion of the substrate is protected by the protective layer such that the water resistance of the veneered element is further improved. For
35 example, the width of the protective layer applied may exceed the width of the substrate, such that the protective layer can be bent over the edge of the substrate and attached to an edge portion of the substrate.

Prior to applying the protective layer 11, the veneer layer may be treated in different ways. For example, the veneer layer 3 may be brushed after pressing. The veneer layer 3 may be mechanically and/or chemically treated after pressing.

In both the embodiment shown in fig. 1b and in fig. 1c, the protective layer 5 11 is in form of a thermoplastic foil. The thermoplastic foil comprises a thermoplastic material. The thermoplastic material may comprise polyvinyl chloride (PVC), polyester, polypropylene (PP), polyethylene (PE), polystyrene (PS), polyurethane (PU), polyethylene terephthalate (PET), polyacrylate, methacrylate, polycarbonate, polyvinyl butyral, polybutylene terephthalate, or a combination 10 thereof. The thermoplastic foil may comprise one or several layers. The layers may comprise the same thermoplastic material, or different thermoplastic materials. In one embodiment, the protective layer 11 comprises applying a first foil comprising a first thermoplastic material, preferably polyvinylchloride (PVC), on the veneer layer (3), and applying a second foil comprising a second thermoplastic material, 15 preferably polyurethane (PU), on the first foil.

The thermoplastic foil may be provided as a continuous web, as shown in figs. 1b and 1c. The thermoplastic foil may be provided as sheets.

The protective layer 11 may comprise wear resistant particles. The wear 20 resistant particles may be applied on the veneer layer 3 prior to apply the thermoplastic foil. The wear resistant particles may be applied between two different layers of the protective layer 11. The wear resistant particles may be applied on the protective layer 11. The wear resistant particles may be aluminium oxide particles such as aluminium. Alternatively, or as a complement, the wear 25 resistant particles may be carborundum, quartz, silica, glass, glass beads, glass spheres, silicon carbide, diamond particles, hard plastics, reinforced polymers and organics. The wear resistant particles preferably have a size of 10-200 μm , preferably 50-100 μm . The wear resistant particles may have an irregular shape. The refractive index of the wear resistant particles 4 may be 1.4-1.7.

Also scratch resistant particles may be applied in a similar manner.

30 In an embodiment (not shown), the protective layer 11 is applied by applying a thermoplastic material in powder form on the veneer layer 3. The thermoplastic material may comprise polyvinyl chloride (PVC), polyester, polypropylene (PP), polyethylene (PE), polystyrene (PS), polyurethane (PU), polyethylene terephthalate (PET), polyacrylate, methacrylate, polycarbonate, polyvinyl butyral, polybutylene 35 terephthalate, or a combination thereof. The protective layer may be applied as one or several layers, comprising the same thermoplastic material, or different thermoplastic materials. As described above, the protective layer 11 formed by a

thermoplastic material in powder form may be applied, both prior to, and after, pressure has been applied to the veneer layer 3 and/or the substrate 1.

Wear resistant particles of the above described type may be applied together with the thermoplastic powder, preferably as mix comprising the thermoplastic material and the wear resistant particles. The mix may further comprise scratch resistant particles. Alternatively, or as a complement, wear resistant particles may be applied on the veneer layer 3, prior to applying the thermoplastic material in powder form, or after the thermoplastic material in powder form has been applied.

In other embodiments, the protective layer 11 comprising a thermoplastic material of the above described type may be applied in form of a slurry and/or paste on the veneer layer 3.

When sufficient pressure is applied as in the embodiment shown in fig. 1b or in the embodiment shown in fig. 1c, the sub-layer 2 permeates through pores, cracks and holes in the veneer layer 3. At least a portion of the sub-layer 2 permeates fully through the veneer layer 3 such that said at least a portion of the sub-layer 2 becomes visible on the veneer layer 3. Said at least a portion of the sub-layer, which permeates or transfers through the veneer layer 3, comprises at least one component of the sub-layer 2. The matter of the sub-layer 2 permeating through the veneer layer 3 may be one or several of the components of the sub-layer 2. For example, the binder of the sub-layer 2 may permeate through the veneer layer. The binder may bring any pigments of the sub-layer 2 to the upper surface of the veneer layer 3 when melted during pressing.

The sub-layer 2 may be in fluid form or powder form when applied. The binder of the sub-layer 2, for example a thermosetting or thermoplastic binder, may be applied as a powder or in fluid form as a dispersion, solution or suspension. If the binder is applied in powder form when applied, the binder melts when applying heat exceeding the melting point of the binder at the pressure applied. Thereby, the binder is in liquid form. By applying a pressure, a fluid pressure of the sub-layer 2 is formed. Thereby, the binder in liquid form may permeate the veneer layer 3. If a thermosetting binder is used, the thermosetting binder is firstly dominated by a melting process up to a first temperature, thereafter the thermosetting binder is dominating by a crosslinking process.

By controlling the degree of permeation of the sub-layer 2 through the veneer layer 3, the design of the veneered element 10 can be controlled. The design of the veneer can be changed by the sub-layer 2 at least partly permeating the veneer layer 3 and thus being visible at the surface of the veneer layer 3. If the veneer layer 3 comprises cracks, cavities and other irregularities, the fluid pressure

required to permeate completely through the veneer layer 3 is decreased, such that portions of the sub-layer 2 easily permeates through the veneer layer 3 and fills the crack or holes. Thereby, putty can be avoided or at least reduced. By including pigments in the sub-layer 2, the design of the veneer can be changed further.

5 For some designs, a large degree of permeation may be desired, and for other designs, less, or varying, permeation may be desired. For example, if a uniform colouring of the veneer such as glazing, lazuring or staining is desired, a uniform fluid pressure is preferred. Preferably, the veneer layer 3 has a uniform thickness and structure. If a varying permeation is desired, resulting in varying pattern of the
10 veneer, a varying fluid pressure is preferred. The veneer layer 3 may have a varying structure including cracks and cavities. The thickness of the veneer layer 3 can also be controlled in order to control the permeation of the sub-layer 2 and thereby the design of the veneer layer 3. The thinner the veneer layer 3 is, the larger amount of the sub-layer 2 permeates through the veneer layer 3.

15 Controlling the design of the veneered element 10 by controlling the permeation of the sub-layer 2 can be made in several ways. The fluid pressure may be controlled and adjusted. The fluid pressure may be varying over the surface of the veneer layer 3. The fluid pressure can be increased if a large degree of permeation of the sub-layer 2 is desired. The fluid pressure can be decreased if less
20 permeation of the sub-layer 2 is desired.

The fluid pressure can be controlled in several ways. The fluid pressure can be controlled by controlling the pressure applied to the substrate 2 and/or veneer layer 3. The temperature applied may have influence on the permeation, for example by changing the viscosity of the sub-layer 2.

25 The fluid pressure may also be controlled by generating a gas pressure in the sub-layer 2. By generating a gas pressure inside the sub-layer 2, the fluid pressure increases. The gas pressure may be generated by including chemical and/or physical blowing agents in the sub-layer. The chemical and/or physical blowing agents increase the fluid pressure when activated.

30 The fluid pressure of the sub-layer 2 may also be controlled by adjusting the concentration of binder in the sub-layer 2. By increasing the concentration of the binder of the sub-layer 2, the more material of the sub-layer 2 may permeate through the veneer layer 3. The part of the sub-layer 2 that flows when heat and pressure is applied increases, and thereby a larger part of the sub-layer 2 may
35 permeate through the veneer layer 3. Furthermore, the type of binder may be adjusted. By increasing the amount of a thermosetting binder in the sub-layer 2, the

part of the sub-layer 2 being flowable when heat and pressure is applied increases, and thereby the fluid pressure.

The fluid pressure of the sub-layer 2 may also be controlled by adjusting the type of binder in the sub-layer 2. By using different type of binders, the fluid
5 pressure of the sub-layer 2 and thereby the permeation can be altered. A rapidly curing binder forms less permeation of the sub-layer 2 through the veneer layer. The fluid pressure may also be controlled by adjusting the formulation of the binder of the sub-layer. Thereby, properties of the sub-layer can be controlled.

The fluid pressure may also be controlled by adjusting the moisture content
10 of the sub-layer. The higher moisture content of the sub-layer, the more steam is formed when applying heat and pressure, thereby increasing the fluid pressure, and consequently, permeation of the sub-layer 2 through the veneer layer 3. Contrary, by decreasing the moisture content of the sub-layer 2 before pressing, for example, by drying the sub-layer 2, the less steam is formed during pressing.

15 Permeation of the sub-layer 2 through the veneer layer 3 may also be controlled by including fillers in the sub-layer. The fillers reduce permeation of the sub-layer by reducing the flowing of the binder. Some fillers, such as wood particles and other organic fillers, absorb the binder to some extent such that the remaining binder that is free to permeate through the veneer layer 3 is reduced. The fluid
20 pressure is thereby also reduced.

Permeation of the sub-layer 2 through the veneer layer 3 may also be controlled by adjusting the thickness of the sub-layer 2, for example by adjusting the amount of sub-layer applied. If the sub-layer 2 is applied as a powder, the amount of powder applied can be adjusted in order to achieve the desired permeation of the
25 sub-layer 2 through the veneer layer 3. The thicker sub-layer, i.e. the larger amount of sub-layer applied, the more the sub-layer 2 permeates through the veneer layer 3.

Permeation of the sub-layer 2 through the veneer layer 3 may also be controlled by forming holes or cracks through the veneer layer 3. By forming, or
30 enlarging existing, holes and cracks, the sub-layer 2 permeates easily through the veneer layer 3. Controlling permeation of the sub-layer 2 through the veneer layer 3 may be performed by forming, or enlarging existing cavities, holes and/or cracks, preferably by brushing.

By adjusting and controlling these parameters, permeation of the sub-layer 2
35 through the veneer layer 3 can be controlled such that a desired look of the veneer surface is obtained, for example as shown in figs. 2-5.

In an embodiment, a produced building panel may be 6-25 mm thick, preferably 8-15 mm thick after pressing, while the core may be 5-22 mm thick, preferably 7-14 mm thick. The sub-layer may be 0.1-2 mm thick after pressing.

Furthermore, a protective layer may be applied to the veneer layer 3. The
5 protective layer may be a coating such as one or several lacquer layers. The coating may be an acrylate or methacrylate coating such as polyurethane coating. The coating may comprise wear and/or scratch resistant particles. The protective layer may be an overlay paper comprising wear resistant particles. The protective layer may be a powder overlay, as described in WO2011/129755, comprising processed
10 wood fibres, a binder and wear resistant particles applied as mix on the veneer surface. If the protective layer comprises or is an overlay paper or a powder overlay, the protective layer is preferably applied before the step of applying heat and pressure. Thereby, the protective layer is cured and attached to the veneer layer in the same step as attaching the veneer layer to the sub-layer and to the substrate.

15 The veneered element 10 may further be treated in different ways, for example brushed, oiled, lacquered, waxed, etc. After pressure has been applied, the veneer layer 3 may be mechanically/and or chemically treated such that a desired appearance of the veneered element 10 is obtained. For examples, the veneer layer 3 may be brushed and/or sanded after pressing.

20 A protective coating may also be applied to the veneer layer 3 prior to pressing. In one embodiment, a wax powder is applied, for example, scattered, on the upper surface of the veneer layer, facing away from the substrate 1, prior to pressing. During pressing, the wax powder forms a protective coating of the veneered element 10.

25 In one embodiment, a primer is applied on the upper surface of the veneer layer, facing away from the substrate 1, prior to pressing. The primer may be a print primer, a primer for preparing the veneer layer 3 for lacquering, etc.

A protective foil may also be applied on the veneer layer 3 prior or after
30 pressing. The protective foil may be thermoplastic foil such as PU or PVC foil, as described above with reference to figs. 1b and 1c.

In the embodiment in figs. 1-4, the substrate 1 comprises a wood-based board such as plywood, HDF, MDF, particleboard etc. In this embodiment the veneered element 10 may be a building panel or a furniture component. If the veneered element 10 is a floor or wall panel, the floor or wall panel may be provided
35 with a mechanical locking system for joining with an adjacent floor or wall panel. The mechanical locking system may be any of the types disclosed in WO 2007/015669, WO 2008/004960, WO 2009/116926, or WO 2010/087752. If the

veneered element 10 is a furniture component for a drawer, shelf or other furniture, the furniture may be provided with a mechanical locking system for joining with another part of the drawer, shelf or furniture component. The mechanical locking system may be of the type described in WO 2012/154113.

5 The veneered element 10 may be provided with decorative grooves or bevels. The decorative grooves or bevels may be extending into the sub-layer 2 such that the sub-layer 2 is visible from the top surface of the veneered element. The decorative groove or bevel may be arranged adjacent an edge of the veneered element provided with the mechanical locking system. By providing a decorative
10 groove extending into the sub-layer 2, a ship-decking appearance may be obtained.

 In the embodiment in fig. 2, the sub-layer 2 has permeated through the veneer layer 3 in some portions of the veneer layer 3 where the resistance of the veneer has been lower, for example as in cracks, holes and cavities of the veneer layer, but to a lower degree through other parts of the veneer layer 3. Portions 2a
15 of the sub-layer 2 are visible on the surface of the veneer layer 3 as shown in fig. 2. The permeation of the sub-layer 2 forms an irregular design of the veneer.

 Fig. 3 shows a cross-section of the veneered element 10 in more detail. Fig. 3 illustrates in more detail how portions 2a of the sub-layer 2 have permeated through the veneer layer 3 such that the portions 2a of the sub-layer 2 are visible from an
20 exposed surface of the veneer layer 3. Fig. 3 illustrates that the sub-layer 2 has permeated through the veneer layer 3 and filled holes 6 of veneer such that portions 2a of the sub-layer 2 are visible through the veneer layer 3. The hole 6 may, as in fig. 3, be a knot. Fig. 3 also illustrates that the sub-layer 2 has permeated through the veneer layer 3 and filled cracks 7 in the veneer such that portions 2a of the veneer layer 3 are visible from the upper surface of the veneer layer 3. Furthermore, fig. 3
25 shows that portions 2a of the sub-layer 2 have permeated through pores 8 of the veneer layer 3 such that portions 2a of the sub-layer 2 are visible on the upper surface of the veneer layer 3. In the embodiment shown in fig. 3, the substrate 1 comprises a wood based board such as plywood, HDF, MDF, particleboard etc. The veneered element 10 is also provided with a balancing layer 5 arranged on a second
30 surface 9 of the substrate 1, opposite the sub-layer 2. The balancing layer 5 may be a powder based balancing layer being applied as a powder. The powder based balancing layer may comprise wood particles such as lignocellulosic and/or cellulosic particles and a binder, preferably a thermosetting binder such as an amino resin.

35 The balancing layer may be a resin impregnated paper, preferably impregnated with a thermosetting binder. The substrate 1 is also provided with a protective layer 11. The protective layer 11 may, for example, be a coating as described above or a

protective layer comprising a thermoplastic material as described above with reference to figs. 1b and 1c.

In fig. 4, also showing a veneered element 10 of the above described type wherein the substrate 1 comprising a wood based board such as plywood, HDF, 5 MDF, particleboard etc. Also in this embodiment the veneered element 10 may be a building panel or a furniture component, and may be provided with a mechanical locking system. However, in this embodiment, compared to the embodiment shown in fig. 2, permeation of the sub-layer 2 is more uniform through the veneer layer 3 such that a more regular design of the veneer layer 3 is obtained. This may be 10 achieved by applying a uniform pressure, and by providing a veneer layer 3 having a uniform porous structure and/or uniform thickness.

Fig. 5 shows an embodiment of the veneered element 10 of the above described type wherein the substrate 1 comprises a paper or a sheet. The substrate 1 forms a carrier for the veneer layer 3 and the sub-layer 2. The veneered element 15 10 according to this embodiment may be bendable and/or flexible. Thereby, post-forming of the veneered element 10 is possible. The veneered element 10 may be adhered to another element in a later operation. The veneered element 10 may form a surface of, for example, a furniture component. In one embodiment, the substrate is a conveyor, and the veneered element 10 is removed from the conveyor 20 after heat and pressure have been applied.

It is contemplated that there are numerous modifications of the embodiments described herein, which are still within the scope of the invention as defined by the appended claims.

It is contemplated that the sub-layer may not directly contact the substrate, 25 but an intermediate layer arranged between the substrate and the sub-layer may be provided.

It is also contemplated that the building panel may be provided with a second veneer layer (not shown) of the above described type applied in the same manner as described above. A sub-layer of the above described type is applied on a 30 second surface of the substrate of the above described type. The second surface of the core faces away from the veneer layer described above with reference to figs. 1-4. In this embodiment, the veneer layer described above with reference to figs. 1-4 is considered as a first veneer layer, and the second veneer layer is arranged oppositely the first veneer layer. A design of the second veneer layer is controlled 35 by determining level of permeation of the sub-layer through the second veneer layer as described above with reference to figs. 1-5.

Examples

Example 1:

400 g/m² of a powder mixture, comprising 40 wt-% wood fibres, 10 wt-% aluminium oxide (Alodur ZWSK 180-ST), 49.5 wt-% melamine formaldehyde resin (Kauramin 773) and 0.5 wt-% of carbon black (Printex 60), was scattered on a 10.0 mm HDF board for forming a sub-layer. The powder layer forming the sub-layer was sprayed with 20 g/m² of an aqueous solution of a release agent (PAT-660). A 0.6 mm oak veneer layer was positioned on the sub-layer prior to pressing the assembly in a short cycle press for 30 seconds at 40 bar with a press plate temperature of 160°C. The resulting product was a veneered HDF having pores and cracks in the veneer layer filled with the cured powder mixture of the sub-layer.

Example 2:

800 g/m² of a powder mixture, comprising of 40 wt-% wood fibres, 10 wt-% aluminium oxide (Alodur ZWSK 180-ST), 49.5 wt-% melamine formaldehyde resin (Kauramin 773) and 0.5 wt-% of carbon black (Printex 60), was scattered on a 10.0 mm HDF board for forming a sub-layer. The powder layer forming the sub-layer was sprayed with 20 g/m² of an aqueous solution of a release agent (PAT-660). A 0.6 mm oak veneer was positioned on the sub-layer prior to pressing the assembly in a short cycle press for 30 seconds at 40 bar with a press plate temperature of 160°C. The resulting product was a veneered HDF having cracks and an increased amount of pores in the veneer layer filled with the cured powder mixture of the sub-layer in comparison with the product of example 1.

Example 3:

400 g/m² of a powder mixture, comprising 17.5 wt-% wood fibres, 17.5 wt-% mineral fibres 10 wt-% aluminium oxide (Alodur ZWSK 180-ST), 52,5 wt-% melamine formaldehyde resin (Kauramin 773) and 0.5 wt-% of carbon black (Printex 60), was scattered on a 10.0 mm HDF board for forming a sub-layer. The powder layer forming the sub-layer was sprayed with 20 g/m² of an aqueous solution of a release agent (PAT-660). A 0.6 mm oak veneer was positioned on the sub-layer prior to pressing the assembly in a short cycle press for 30 seconds at 40 bar with a press plate temperature of 160°C. The resulting product was a veneered HDF having cracks and a decreased amount of pores in the veneer layer filled with the cured powder mixture of the sub-layer in comparison with the product of example 1.

Example 4:

400 g/m² of a powder mixture, comprising 10 wt-% aluminium oxide (Alodur ZWSK 180-ST), 89.5 wt-% melamine formaldehyde resin (Kauramin 773) and 0.5 wt-% of carbon black (Printex 60), was scattered on a 10.0 mm HDF board for forming a sub-layer. The powder layer forming the sub-layer was sprayed with 20 g/m² of an aqueous solution of a release agent (PAT-660). A 0.6 mm oak veneer was positioned on the sub-layer prior to pressing the assembly in a short cycle press for 30 seconds at 40 bar with a press plate temperature of 160°C. The resulting product was a veneered HDF having cracks and an increased amount of pores in the veneer filled with the cured powder mixture of the sub-layer in comparison with the product of the example 1.

Example 5:

400 g/m² of a powder mixture, comprising 40 wt-% wood fibres, 10 wt-% aluminium oxide (Alodur ZWSK 180-ST), 49.5 wt-% thermoplastic binder (Vinnapas 5010 N) and 0.5 wt-% of carbon black (Printex 60), was scattered on a 10.0 mm HDF board for forming a sub-layer. The powder layer forming the sub-layer was sprayed with 20 g/m² of an aqueous solution of a release agent (PAT-660). A 0.6 mm oak veneer was positioned on the sub-layer prior to pressing the assembly in a short cycle press for 30 seconds at 40 bar with a press plate temperature of 160°C. The resulting product was a veneered HDF having a decreased amount of pores and cracks in the veneer layer filled with the cured powder mixture compared to the product of example 1.

Example 6:

400 g/m² of a liquid mixture, comprising 45 wt-% water, 10 wt-% aluminium oxide (Alodur ZWSK 180-ST), 44.5 wt-% melamine formaldehyde resin (Kauramin 773) and 0.5 wt-% of carbon black (Printex 60), was applied on a 10.0 mm HDF board for forming a sub-layer. A 0.6 mm oak veneer was positioned on the liquid layer forming the sub-layer prior to pressing the assembly in a short cycle press for 30 seconds at 40 bar with a press plate temperature of 160°C. The resulting product was a veneered HDF having pores and cracks in the veneer layer filled with the cured mixture.

Example 7:

200 g/m² of a polyurethane powder (Desmomelt VP KA 8702) was applied on a 10.0 mm HDF board for forming a sub-layer. A 0.6 mm oak veneer was positioned on the sub-layer prior to pressing. Wear resistant particles in form of 40 g/m² of aluminium

oxide (Alodur ZWSK 180-ST) were applied on the oak veneer prior to pressing. Further, a 0.05 mm polyurethane film (LPT 4802) was applied on the oak veneer with the wear resistant particles prior to pressing. The assembly was pressed in a short cycle press for 40 seconds at 20 bar with a temperature of 140 °C and thereafter cooled to 50°C. The resulting product was a veneered HDF having pores and cracks in the veneer layer filled with the sub-layer. The veneer layer was protected by the polyurethane film.

Example 8:

210 g/m² of a powder mix comprising 44 wt% wood fibre, 46 wt% phenol-formaldehyde resin (Prefere 4976), 5 wt% titanium dioxide and 5 wt% aluminium oxide (Alodur ZWSK 180 ST-180) was applied on a 10.0 mm HDF board for forming a sub-layer. A 0.6 mm oak veneer was applied on the sub-layer prior to pressing. A 0.05 mm polyurethane film (LPT4802) was applied on the oak veneer prior to pressing. The assembly was pressed in a short cycle press for 40 seconds at 20 bar with a temperature of 140 °C and thereafter cooled to 50°C. The resulting product was a veneered HDF having pores and cracks in the veneer layer filled with the cured sub-layer. The veneer layer was protected by the polyurethane film.

Example 9:

300 g/m² of a powder mix comprising 30.41 wt% wood fibre, 52.5 wt% melamine-formaldehyde resin (Kauramin 773), 3.4 wt% titanium dioxide, 8.8 wt% aluminium oxide (Alodur ZWSK 180-ST), 4.7 wt% pigment Lichtgrau G10512, 0.15 wt% pigment Gelb 265 and 0.04 wt% pigment carbon black (Black 920) was applied on a 10.0 mm HDF board for forming a sub-layer. A 0.06 mm oak veneer was applied on the sub-layer prior to pressing. A 0.05 mm polyurethane film (LPT 4802) was applied on the veneer prior to pressing. The assembly was pressed in a short cycle press for 120 seconds at 20 bar and a temperature of 160°C. The resulting product was a veneered HDF having pores and cracks in the veneer layer filled with the cured sub-layer. The veneer layer was protected by the polyurethane film.

Example 10:

40 g/m² of a polyurethane powder (Desmomelt VP KA 8702) was applied on a 10.0 mm HDF board for forming a sub-layer. A 0.9 mm cork veneer was applied on the sub-layer prior to pressing. Wear resistant particles in form of 40 g/m² aluminium oxide (Alodur ZWSK 180-ST) were applied on the cork veneer prior to pressing. A 0.05 mm polyurethane film (LPT 4802) was applied on the cork veneer and the wear

resistant particles prior to pressing. The assembly was pressed in a short cycle press for 40 seconds at 20 bar with a temperature of 140°C and thereafter cooled to 50°C. The resulting product was a veneered HDF having pores and cracks in the veneer layer filled with the sub-layer. The veneer layer was protected by the polyurethane film.

Example 11:

40 g/m² of a polyurethane powder (Desmomelt VP KA 8702) was applied on a 10.0 mm HDF board for forming a sub-layer. A 0.9 mm cork veneer was applied on the sub-layer prior to pressing. A first 0.05 mm polyurethane film (LPT 4802) was applied on the cork veneer. Wear resistant particles in form of 40 g/m² aluminium oxide (Alodur ZWSK 180-ST) were applied on the cork veneer prior to pressing. A second 0.05 mm polyurethane film (LPT 4802) was applied on the first polyurethane film and the wear resistant particles prior to pressing. The assembly was pressed in a short cycle press for 40 seconds at 20 bar with a temperature of 140°C and thereafter cooled to 50°C. The resulting product was a veneered HDF having pores and cracks in the veneer layer filled with the sub-layer. The veneer layer was protected by the polyurethane film.

CLAIMS

1. A method of producing a veneered element (10), comprising
- providing a substrate (1),
 - 5 - applying a sub-layer (2) on a surface of the substrate (1),
 - applying a veneer layer (3) on the sub-layer (2),
 - applying a protective layer (11) comprising a thermoplastic material on the veneer layer (3), and
 - applying pressure to the veneer layer (3) and/or the substrate (1), such that
 - 10 at least a portion (2a) of the sub-layer (2) permeates through the veneer layer (3).
2. The method according to claim 1, wherein the thermoplastic material comprises polyvinyl chloride (PVC), polyester, polypropylene (PP), polyethylene (PE), polystyrene (PS), polyurethane (PU), polyethylene terephthalate (PET), polyacrylate,
- 15 methacrylate, polycarbonate, polyvinyl butyral, polybutylene terephthalate, or a combination thereof.
3. The method according to claim 1 or 2, wherein the protective layer (11) comprises at least one thermoplastic foil.
- 20
4. The method according to any one of the preceding claims, wherein applying the protective layer comprises applying a first foil comprising a first thermoplastic material, preferably polyvinylchloride (PVC), on the veneer layer (3), and applying a second foil comprising a second thermoplastic material, preferably polyurethane
- 25 (PU), on the first foil.
5. The method according to claim 1 or 2, wherein applying the protective layer (11) comprises applying the thermoplastic material in powder form on the veneer layer (3).
- 30
6. The method according any one of the preceding claims, wherein the protective layer (11) further comprises wear resistant particles.
7. The method according to any one of the preceding claims, wherein the sub-
- 35 layer (2) further comprises pigments.

8. The method according to any one of the preceding claims, wherein the substrate (1) is a wood-based board.

5 9. The method according to any one of the preceding claims, further comprising controlling a design of the veneer layer by controlling permeation of the sub-layer (2) through the veneer layer (3).

10 10. The method according to claim 9, wherein controlling permeation of the sub-layer (2) through the veneer layer (3) comprises controlling a fluid pressure of the sub-layer (2).

11. The method according to claim 10, wherein controlling the fluid pressure of the sub-layer (2) when applying pressure includes adjusting one or more of the following parameters:

- 15
- concentration of a binder in the sub-layer (2);
 - type of binder in the sub-layer;
 - formulation of the binder in the sub-layer;
 - moisture content of the sub-layer (2);
 - the pressure applied to the veneer layer (3) and/or the substrate (1);

20

 - a gas pressure in the sub-layer (2);
 - concentration of fillers in the sub-layer (2); and
 - thickness of the veneer layer (3).

12. The method according to claim 11, wherein generating the gas pressure comprises including chemical and/or physical blowing agents in the sub-layer (2).

13. The method according to any one of claims 9-12, wherein controlling permeation of the sub-layer (2) through the veneer layer (3) comprises abrasive machining of the veneer layer (3) prior to applying pressure to the veneer layer (3) and/or the substrate (1).

14. The method according to claim 13, wherein the abrasive machining comprises brushing the veneer layer (3) prior to applying pressure to the veneer layer (3) and/or the substrate (1).

35

15. The method according to any one of claims 9-14, wherein controlling permeation of the sub-layer (2) through the veneer layer (3) comprises forming holes (6), cavities (6) and/or cracks (7) in the veneer layer (3).

5 16. The method according to any one of the preceding claims, wherein said at least a portion (2a) of the sub-layer (2) permeates through pores (8) of the veneer layer (3).

10 17. The method according to any one of the preceding claims, wherein said at least a portion (2a) of the sub-layer (2) permeates through cracks (7) and/or holes (6) of the veneer layer (3).

15 18. The method according to any one of the preceding claims, wherein the veneer layer (3) comprises a wood veneer, a cork veneer, or a stone veneer.

19. The method according to any one of the preceding claims, wherein the sub-layer (2) comprises a binder.

20 20. The method according to claim 19, wherein the binder is a thermosetting binder or a thermoplastic binder.

21. The method according to any one of the preceding claims, wherein the sub-layer (2) comprises wear resistant particles.

25 22. The method according to any one of the preceding claims, wherein after pressure has been applied, the veneer layer comprises embossed portions, wherein a portion of the sub-layer (2) is more compressed under an embossed portion than under a non-embossed surface portion.

30 23. A veneered element (10), comprising
a substrate (1),
a sub-layer (2) arranged on the substrate (1), and
a veneer layer (3) arranged on the sub-layer (2),
a protective layer (11) comprising a thermoplastic material arranged on the
35 veneer layer (3), and
wherein at least a portion (2a) of the sub-layer (2) is permeated through the veneer layer (3) such that at least a portion (2a) of the sub-layer (2) is visible at the

surface of the veneer layer (3) facing away from the substrate (1).

24. The veneered element according to claim 23, wherein the protective layer (11) further comprises wear resistant particles.

5

25. The veneered element according to claim 23 or 24, wherein the thermoplastic material comprises polyvinyl chloride (PVC), polyester, polypropylene (PP), polyethylene (PE), polystyrene (PS), polyurethane (PU), polyethylene terephthalate (PET), polyacrylate, methacrylate, polycarbonate, polyvinyl butyral, polybutylene terephthalate, or a combination thereof.

10

26. The veneered element according to claim any one of claims 23-25, wherein the protective layer (11) comprises at least one thermoplastic foil.

15

27. The veneered element according to any one of claims 23-26, the protective layer comprises a first foil comprising a first thermoplastic material, preferably polyvinylchloride (PVC), and a second foil comprising a second thermoplastic material, preferably polyurethane (PU).

20

28. The veneered element according to any one of claims 23-27, wherein the sub-layer (2) comprises pigments.

29. The veneered element according to any one of claims 23-28, wherein the sub-layer (2) comprises wear resistant particles.

25

30. The veneered element according to any one of claims 23-29, wherein the sub-layer (2) comprises fillers.

30

31. The veneered element according to any one of claims 23-30, wherein said at least a portion (2a) of the sub-layer (2) is permeated through pores (8) of the veneer layer (3).

35

32. The veneered element according to any one of claims 23-31, wherein the veneer layer (3) comprises embossed portions, wherein a portion of the sub-layer (2) is more compressed under an embossed portion than under a non-embossed surface portion.

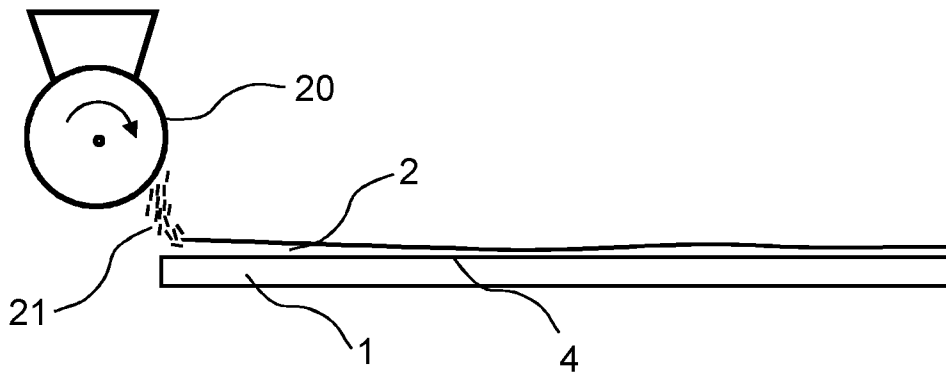

FIG. 1A

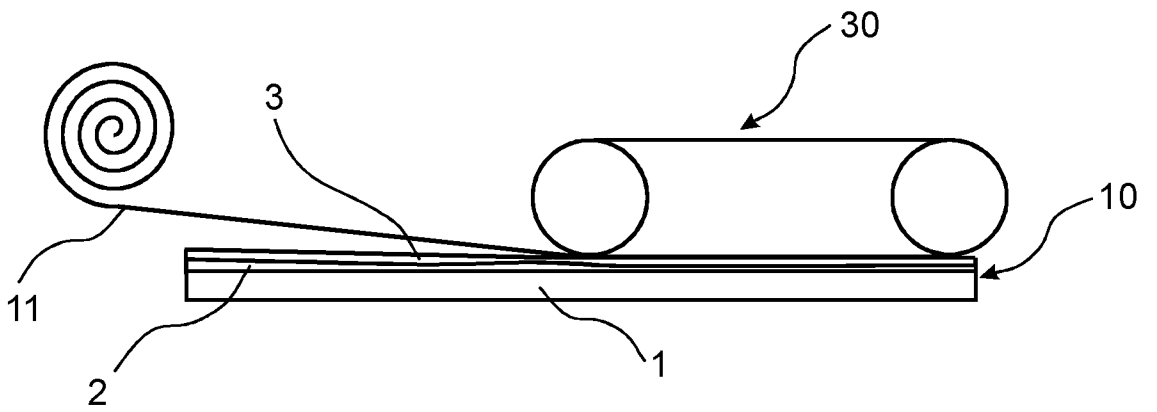

FIG. 1B

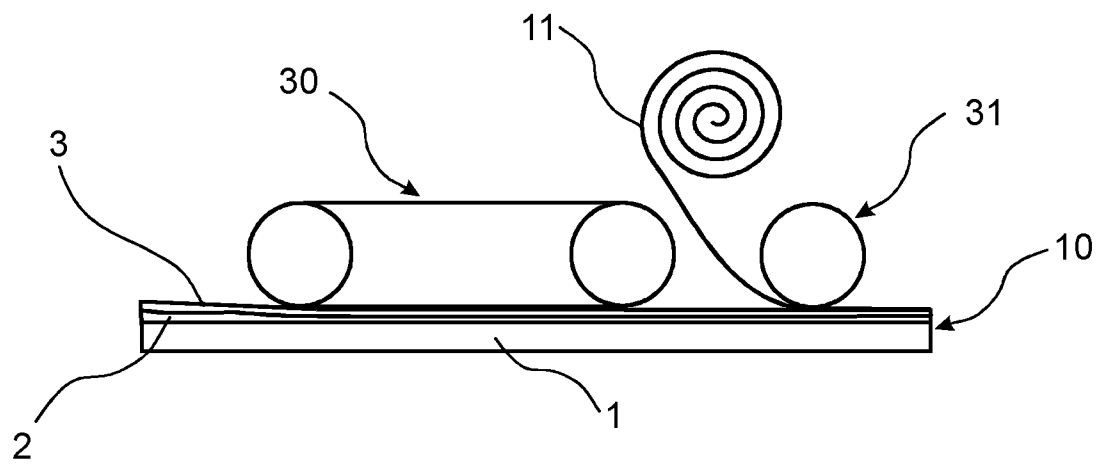

FIG. 1C

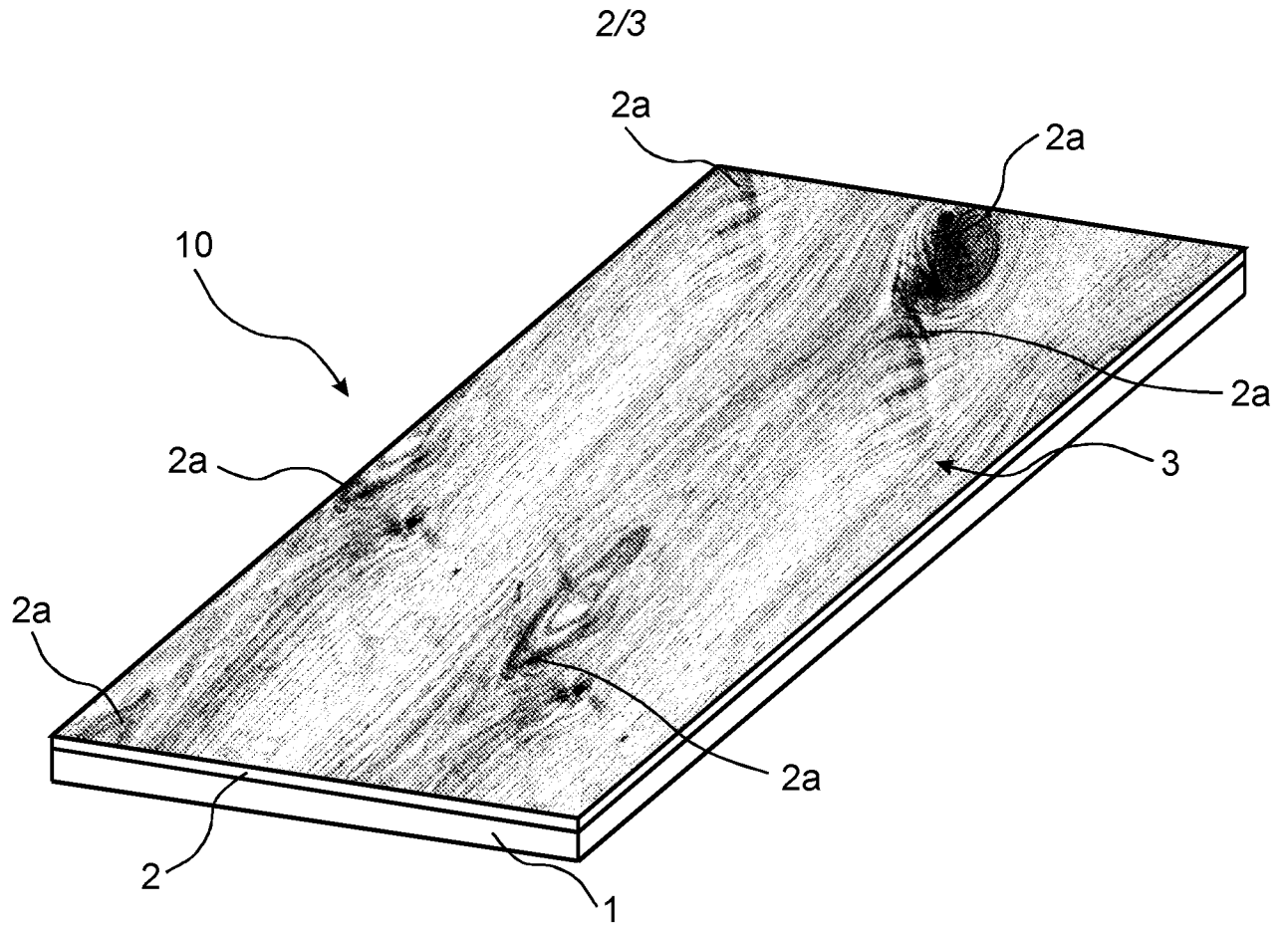

FIG. 2

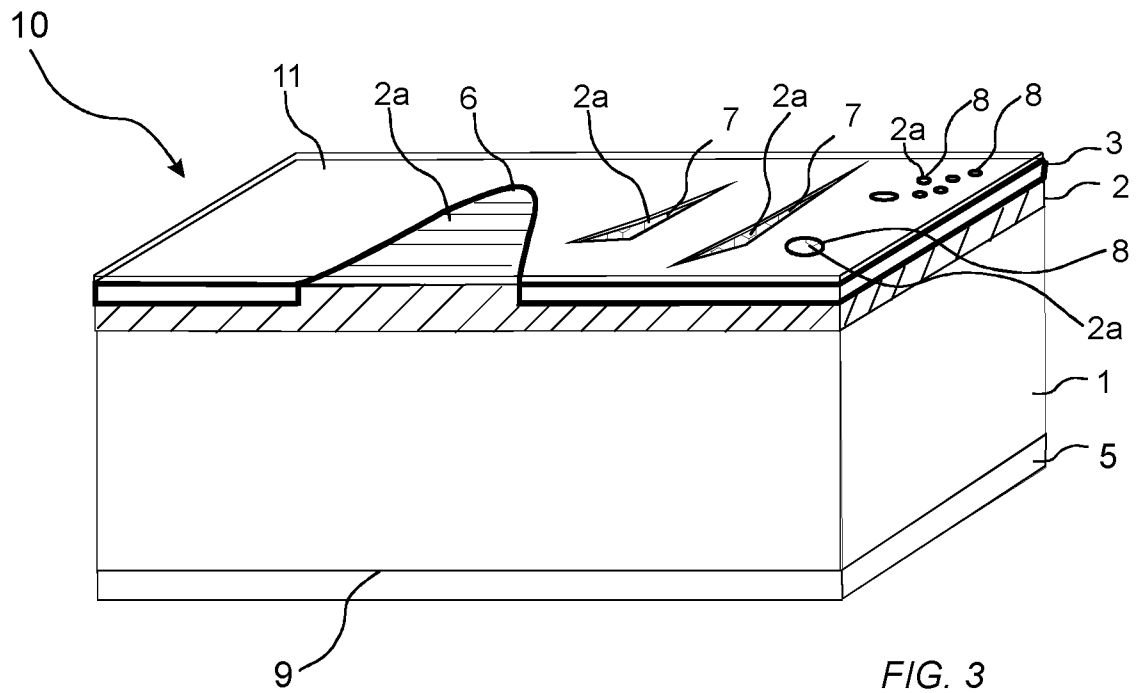
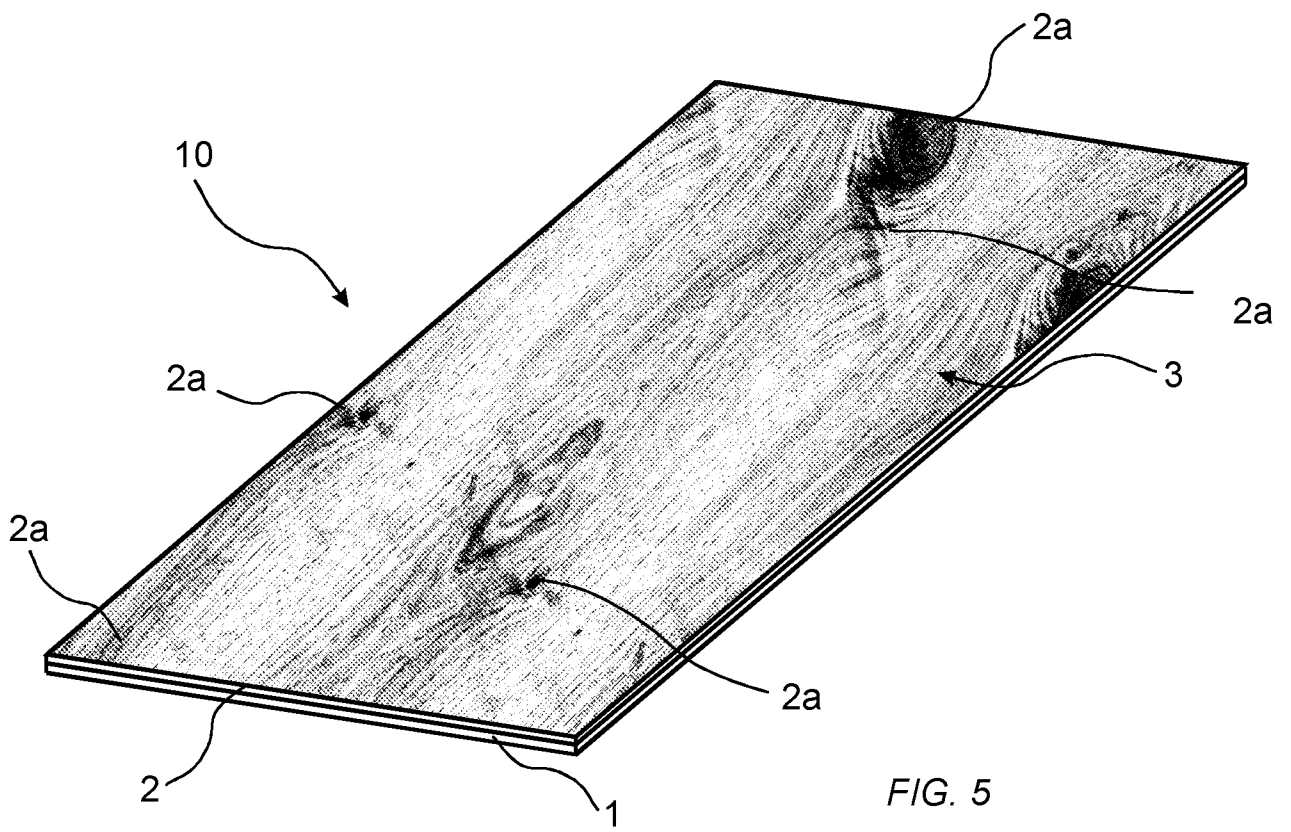
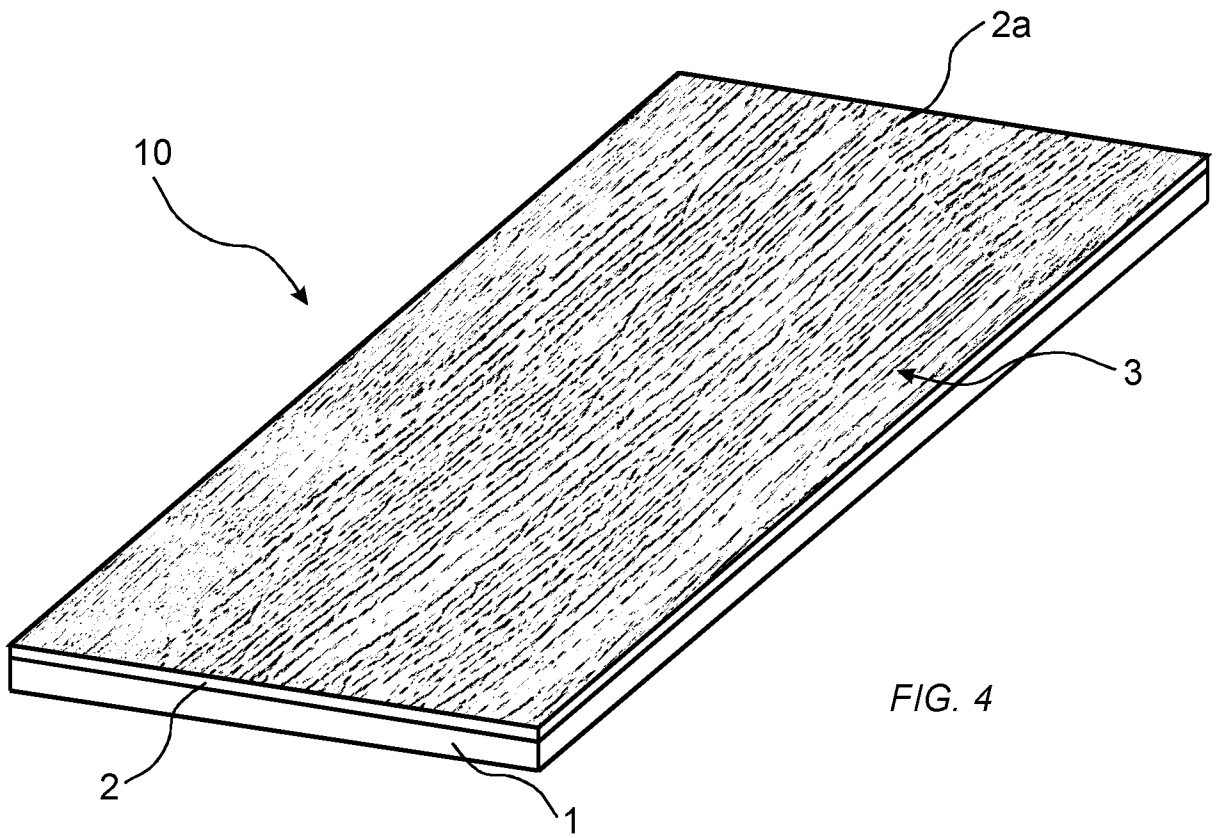

FIG. 3



INTERNATIONAL SEARCH REPORT

International application No.
PCT/SE2015/050524

A. CLASSIFICATION OF SUBJECT MATTER

IPC: see extra sheet

According to International Patent Classification (IPC) or to both national classification and IPC

B. FIELDS SEARCHED

Minimum documentation searched (classification system followed by classification symbols)

IPC: B27D, B32B, B44C

Documentation searched other than minimum documentation to the extent that such documents are included in the fields searched

SE, DK, FI, NO classes as above

Electronic data base consulted during the international search (name of data base and, where practicable, search terms used)

EPO-Internal, PAJ, WPI data

C. DOCUMENTS CONSIDERED TO BE RELEVANT

Category*	Citation of document, with indication, where appropriate, of the relevant passages	Relevant to claim No.
Y	WO 2009065769 A2 (VAELINGE INNOVATION BELGIUM BV ET AL), 28 May 2009 (2009-05-28); page 13, line 15 - page 14, line 11; page 34, line 15 - line 28; figures 10a-c --	1-32
Y	US 2720478 A (HOGG JAMES H), 11 October 1955 (1955-10-11); column 4, line 21 - column 5, line 15; column 7, line 1 - line 16; figures 1-4 --	1-32
Y	US 2831794 A (ELMENDORF ARMIN), 22 April 1958 (1958-04-22); column 4, line 14 - line 53; column 5, line 19 - line 29; figure 1; claims 1-11 --	1-32

 Further documents are listed in the continuation of Box C. See patent family annex.

* Special categories of cited documents:

"A" document defining the general state of the art which is not considered to be of particular relevance

"E" earlier application or patent but published on or after the international filing date

"L" document which may throw doubts on priority claim(s) or which is cited to establish the publication date of another citation or other special reason (as specified)

"O" document referring to an oral disclosure, use, exhibition or other means

"P" document published prior to the international filing date but later than the priority date claimed

"T" later document published after the international filing date or priority date and not in conflict with the application but cited to understand the principle or theory underlying the invention

"X" document of particular relevance; the claimed invention cannot be considered novel or cannot be considered to involve an inventive step when the document is taken alone

"Y" document of particular relevance; the claimed invention cannot be considered to involve an inventive step when the document is combined with one or more other such documents, such combination being obvious to a person skilled in the art

"&" document member of the same patent family

Date of the actual completion of the international search

13-08-2015

Date of mailing of the international search report

14-08-2015

Name and mailing address of the ISA/SE

Patent- och registreringsverket
Box 5055
S-102 42 STOCKHOLM
Facsimile No. + 46 8 666 02 86

Authorized officer

Monika Bohlin

Telephone No. + 46 8 782 28 00

INTERNATIONAL SEARCH REPORT

International application No.
PCT/SE2015/050524

C (Continuation). DOCUMENTS CONSIDERED TO BE RELEVANT		
Category*	Citation of document, with indication, where appropriate, of the relevant passages	Relevant to claim No.
Y	US 5059472 A (LE BELL JEAN ET AL), 22 October 1991 (1991-10-22); abstract; column 1, line 8 - line 63; column 3, line 31 - line 61; column 4, line 3 - line 11; column 5, line 28 - line 54; column 8, line 24 - line 59; column 9, line 23 - line 31; figures 1-3 --	1-32
A	US 3729368 A (INGHAM R ET AL), 24 April 1973 (1973-04-24); column 1, line 13 - line 42; column 2, line 57 - line 59; column 4, line 20 - line 26 --	1-32
A	EP 2263867 A1 (HUELSTA WERKE HUELS KG), 22 December 2010 (2010-12-22); abstract; paragraphs [0016], [0035]; figure 4; claims 1, 3, 6 --	1-32
A	DE 3634885 A1 (HOECHST AG), 21 April 1988 (1988-04-21); abstract; claim 8 --	1-32
A	US 2831793 A (ELMENDORF ARMIN), 22 April 1958 (1958-04-22); whole document; figures 1-4 --	1-32
A	US 2634534 A (OWEN BROWN), 14 April 1953 (1953-04-14); figures 1-3,6; claims 1-7 --	1-32
A	US 2630395 A (VERNON MCCULLOUGH KENNETH ET AL), 3 March 1953 (1953-03-03); figures 1-2; claims 1-5 --	1-32
A	WO 2009050565 A1 (FLOORING IND LTD SARL ET AL), 23 April 2009 (2009-04-23); abstract; figure 1 --	1-32
A	US 3308013 A (BRYANT BENJAMIN S), 7 March 1967 (1967-03-07); column 2, line 11 - line 24; figures 1-3 --	1-32
A	US 20130025216 A1 (REICHWEIN DAVID P ET AL), 31 January 2013 (2013-01-31); abstract; figure 1 --	1-32

INTERNATIONAL SEARCH REPORT

International application No.
PCT/SE2015/050524

C (Continuation). DOCUMENTS CONSIDERED TO BE RELEVANT

Category*	Citation of document, with indication, where appropriate, of the relevant passages	Relevant to claim No.
A	US 2419614 A (WELCH ARTHUR R), 29 April 1947 (1947-04-29); column 2, line 17 - column 4, line 71; figures 1-4 -- -----	1-32

Continuation of: second sheet

International Patent Classification (IPC)

B32B 21/14 (2006.01)

B27D 1/06 (2006.01)

B44C 5/04 (2006.01)

B32B 21/02 (2006.01)

INTERNATIONAL SEARCH REPORT
Information on patent family members

International application No.
PCT/SE2015/050524

WO	2009065769 A2	28/05/2009	CN	104005538 A	27/08/2014
			CN	104002357 A	27/08/2014
			CN	104002356 A	27/08/2014
			CN	104002349 A	27/08/2014
			CN	101909836 B	09/07/2014
			DE	202008018477 U1	27/03/2014
			EP	2242625 A2	27/10/2010
			JP	2011522138 A	28/07/2011
			JP	5595924 B2	24/09/2014
			KR	101510148 B1	10/04/2015
			KR	20100098414 A	06/09/2010
			NZ	586169 A	29/06/2012
			RU	2010125230 A	27/12/2011
			RU	2483867 C2	10/06/2013
			SG	186004 A1	28/12/2012
			US	8431054 B2	30/04/2013
			US	20100300030 A1	02/12/2010
US	2720478 A	11/10/1955	NONE		
US	2831794 A	22/04/1958	NONE		
US	5059472 A	22/10/1991	AT	79796 T	15/09/1992
			CA	1302221 C	02/06/1992
			DE	3686583 T2	21/01/1993
			DK	292287 A	04/06/1987
			DK	159909 C	27/05/1991
			EP	0280681 A1	07/09/1988
			ES	2003155 A6	16/10/1988
			FI	78253 C	10/07/1989
			FI	881973 A0	27/04/1988
			FI	854237 A0	29/10/1985
			FI	93088 C	27/02/1995
			JP	63501631 A	23/06/1988
			JP	0653361 B2	20/07/1994
			NO	872703 A	26/06/1987
			NO	168160 C	22/01/1992
			PT	83641 A	01/11/1986
			RU	1828432 C	15/07/1993
			WO	8702616 A1	07/05/1987
US	3729368 A	24/04/1973	NONE		
EP	2263867 A1	22/12/2010	AT	548188 T	15/03/2012
			ES	2384014 T3	28/06/2012
			WO	2010145766 A1	23/12/2010
DE	3634885 A1	21/04/1988	NONE		

INTERNATIONAL SEARCH REPORT

Information on patent family members

International application No.

PCT/SE2015/050524

US	2831793 A	22/04/1958	NONE			
US	2634534 A	14/04/1953	NONE			
US	2630395 A	03/03/1953	NONE			
WO	2009050565 A1	23/04/2009	BE	1017821 A5	04/08/2009	
			CA	2702712 A1	23/04/2009	
			CN	101827691 A	08/09/2010	
			EP	2200794 A1	30/06/2010	
			RU	2010119460 A	27/11/2011	
			RU	2471619 C2	10/01/2013	
			US	20100311854 A1	09/12/2010	
US	3308013 A	07/03/1967	NONE			
US	20130025216 A1	31/01/2013	NONE			
US	2419614 A	29/04/1947	GB	665672 A	30/01/1952	