

M. D. PHELAN.
STARTING AND STOPPING MECHANISM.
APPLICATION FILED JAN. 11, 1907. RENEWED NOV. 22, 1909.

958,004.

Patented May 17, 1910.

3 SHEETS—SHEET 1.

Fig. 1.

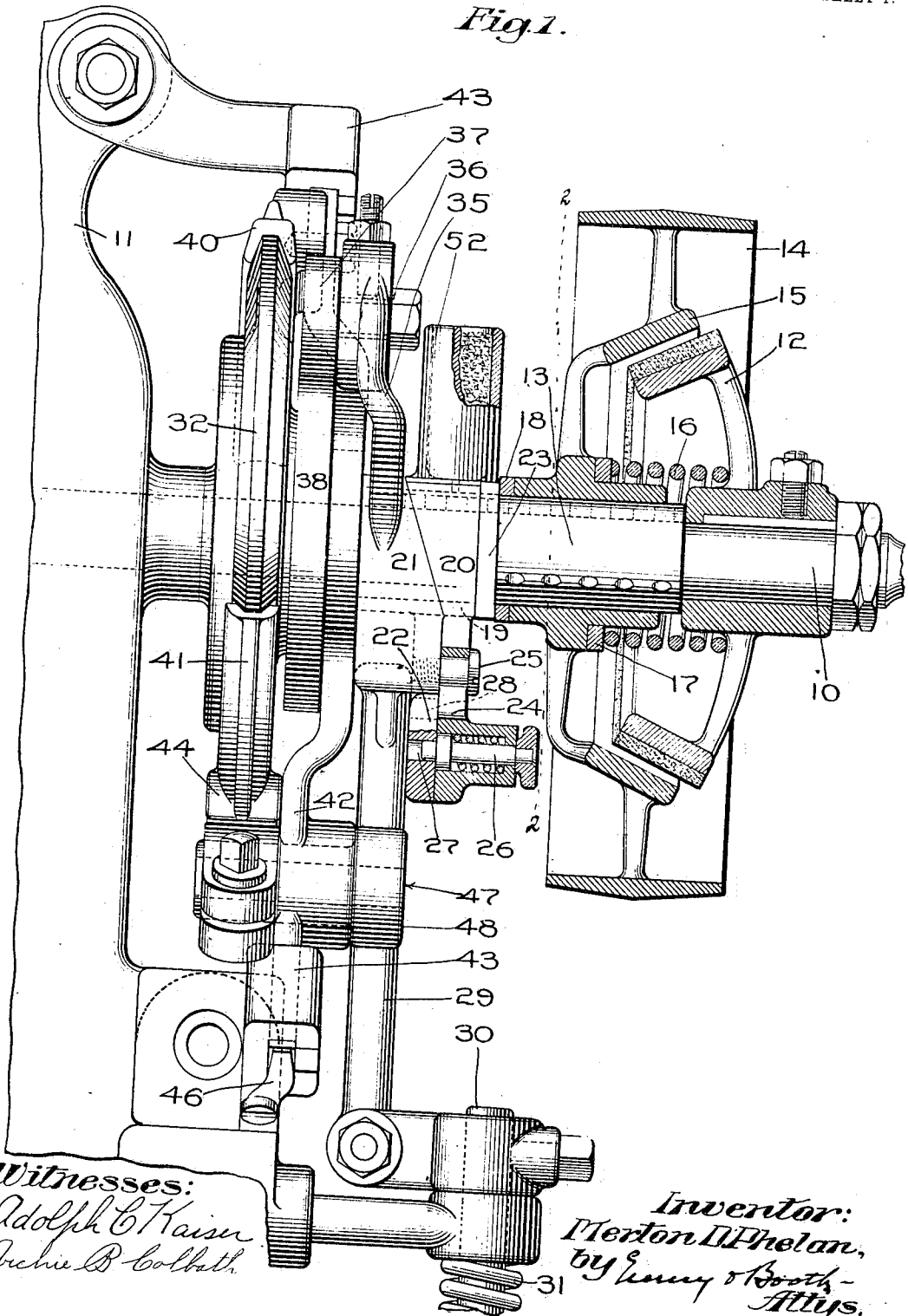

Witnesses:
Adolph C. Kaiser
Archie B. Colbath.

Inventor:
Merton D. Phelan,
by Henry S. Booth-
Attys.

M. D. PHELAN.
STARTING AND STOPPING MECHANISM.

APPLICATION FILED JAN. 11, 1907. RENEWED NOV. 22, 1909.

958,004.

Patented May 17, 1910.

3 SHEETS—SHEET 2.

Fig. 2.

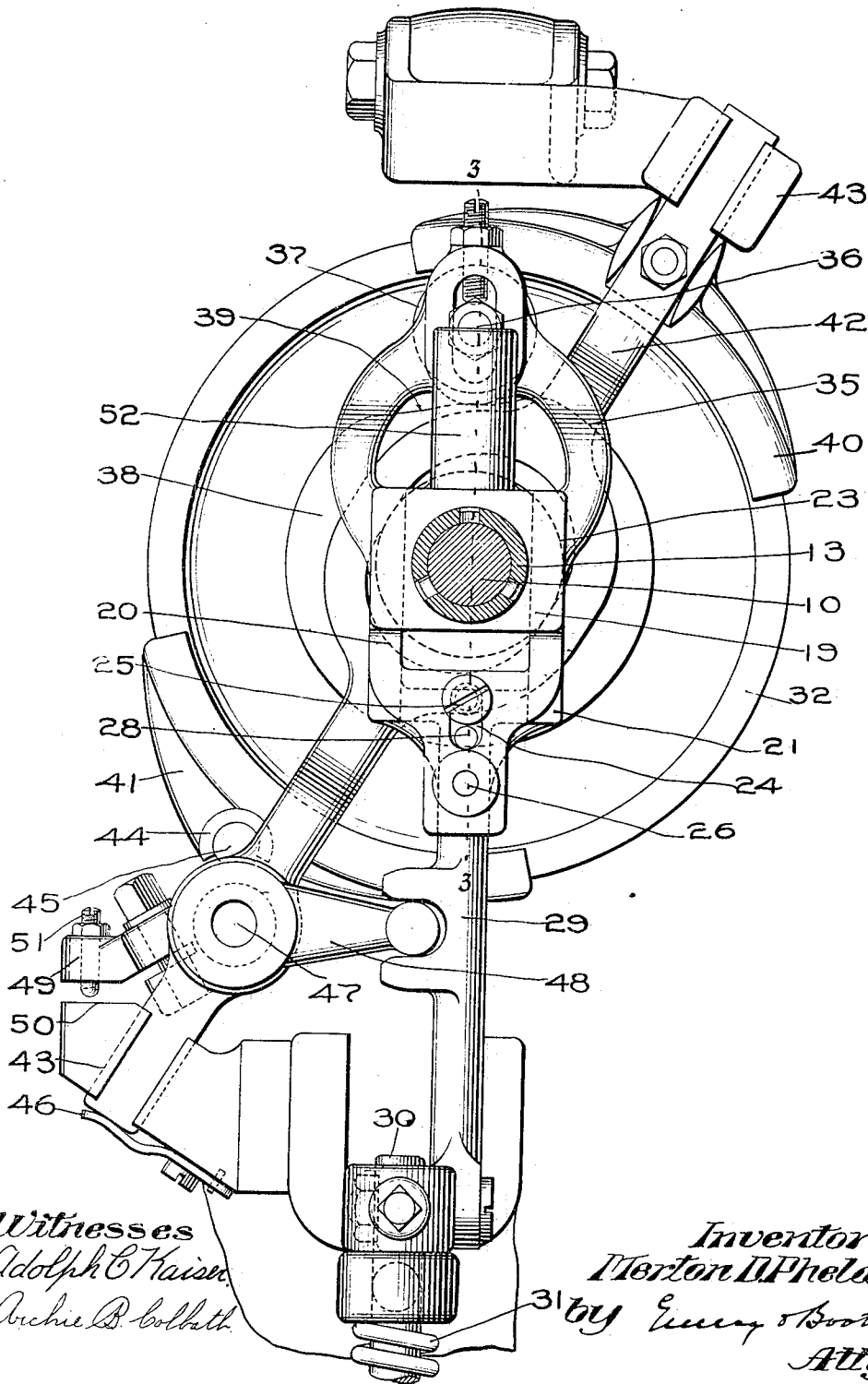

Witnesses
Adolph C. Kaiser
Archie B. Colbath

Inventor:
Merton D. Phelan
by *Ernest Booth-*
Atty

M. D. PHELAN.

STARTING AND STOPPING MECHANISM.

APPLICATION FILED JAN. 11, 1907. RENEWED NOV. 22, 1909.

958,004.

Patented May 17, 1910.

3 SHEETS—SHEET 3.

Fig. 3.

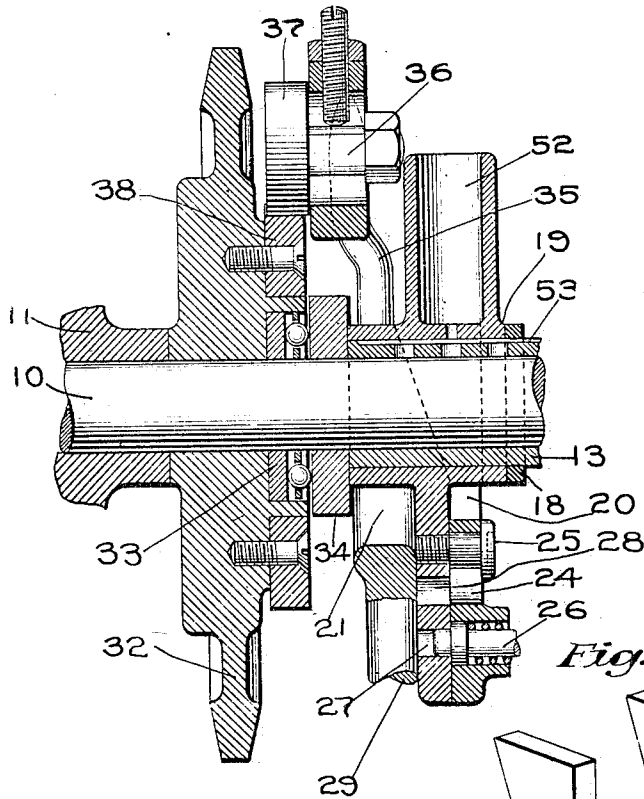

Fig. 4.

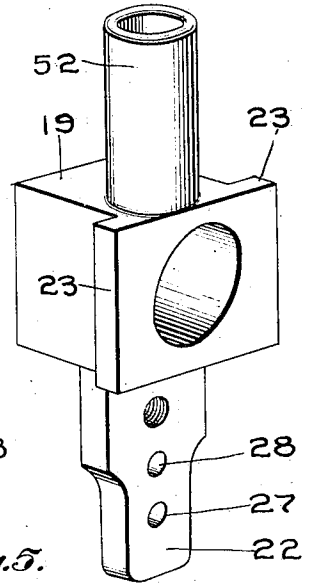
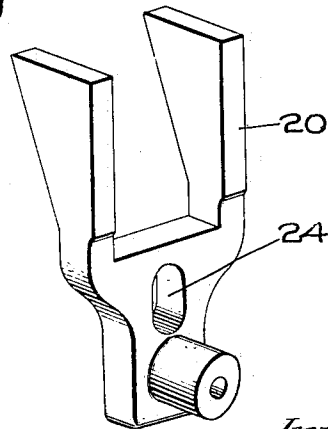

Fig. 5.



Witnesses:

Adolph C. Kaiser
Archie B. Colbath.

Inventor:

Merton D. Phelan,
by Emory Booth -
Attys.

UNITED STATES PATENT OFFICE.

MERTON D. PHELAN, OF BOSTON, MASSACHUSETTS, ASSIGNOR, BY MESNE ASSIGNMENTS, TO MANUFACTURERS MACHINE COMPANY, OF MONTCLAIR, NEW JERSEY, A CORPORATION OF NEW JERSEY.

STARTING AND STOPPING MECHANISM.

958,004.

Specification of Letters Patent. Patented May 17, 1910.

Application filed January 11, 1907, Serial No. 351,844. Renewed November 22, 1909. Serial No. 529,315.

To all whom it may concern:

Be it known that I, MERTON D. PHELAN, a citizen of the United States, residing at Boston, in the county of Suffolk and State of Massachusetts, have invented an Improvement in Starting and Stopping Mechanism, of which the following description, in connection with the accompanying drawings, is a specification, like characters on the drawings representing like parts.

Starting and stopping mechanisms embodying this invention are particularly adapted for use on high speed machines which are desired to be stopped promptly and with acting parts of the machines in predetermined positions.

The invention is applicable with especially advantageous results to machines for inserting fastenings or the like in soles and heels of boots and shoes. Such machines are preferably driven at a very high rate of speed and it is frequently desirable so to control the operation of the machine that its driving shaft may be rotated for but a single revolution at usual speed and still be promptly and accurately arrested with the machine parts in desired positions. While this invention provides for all such requirements of high speed machines, it is of course susceptible of application to various sorts of machines regardless of their operating speed.

The nature of the invention may be best understood from a description of a practical embodiment thereof, such as is shown for purposes of illustration in the accompanying drawings in which,

Figure 1 is a side elevation of a starting and stopping mechanism partly in section on a vertical axial plane of the driving pulley of the mechanism; Fig. 2 is an end elevation (viewed from the right in Fig. 1) partly in section on the line 2—2 of Fig. 1; Fig. 3 is a detail vertical section on the line 3—3 of Fig. 2; and Figs. 4 and 5 are detail perspectives.

The illustrative embodiment of the invention represented in the drawings shows a desirable form of starting and stopping mechanism as employed for controlling the rotation of a shaft 10. It suffices to say that said shaft may be associated in any practicable manner with whatever machine is required to be driven.

Referring to Fig. 1, the shaft 10 is journaled in a part 11 of a frame casting and is driven through the agency of a clutch member 12 fixed upon the shaft. Adjacent said clutch member 12 and rotatably mounted upon a loose sleeve 13 encircling the shaft 10, is a belt pulley 14 which carries a second clutch member 15 arranged for driving engagement with the member 12. The belt pulley 14 is shifted axially on the sleeve 13 for clutching and unclutching; and the clutch members are maintained normally disengaged by a coil-spring 16 interposed between the hubs of said members and bearing at one end upon a loose ring 17 which supplies easy sliding contact with the hub of the clutch member 15 and permits relative rotation of the clutch members unimpeded by the spring. The spring 16 when unrestrained holds the hub of the clutch member 15 against a ring 18, loosely mounted on the sleeve 13 and held against the pressure of the spring by means presently to be described.

The clutch is operated by wedge devices possessing several features of advantage. These devices comprise a squared block 19; a wedge 20 and a second wedge 21 which, for convenience in description, may be designated respectively the "negative" and "positive" wedges, since the former is merely the passive agency through which the latter acts positively to throw the clutch members into engagement.

The block 19 is shown detached in Fig. 4; and the negative wedge 20 in Fig. 5. Said block 19 is loosely mounted on the sleeve 13 and has an integral depending wedge-adjusting finger 22. The negative wedge 20 is bifurcated (see Fig. 5) and straddles the block 19, the vertical edges of the bifurcations contacting with wings 23 projecting laterally from the block. The lower portion of the wedge 20 has a slot 24 which incloses a stud 25 projecting from the wedge-adjusting finger 22 of the block 19. Also the wedge 20 carries a spring plunger 26, arranged to project alternatively into holes 27 and 28 of the finger 22. The block 19, being mounted on the sleeve 13, is incapable of vertical movement relative to the shaft 10; but the wedge 20 may be adjusted vertically on the block 19 to two positions de-

terminated by engagement of the plunger 26, and holes 27 and 28 respectively, the slot 24 and stud 25 serving to guide such adjustment and maintain proper relative alignment of the finger 22 and the wedge 20. The plunger 26 is provided with a head or handle whereby it may be withdrawn conveniently from one hole preparatory to adjusting the wedge 20 to the position determined by the other hole. When the plunger 26 rests in the lower hole 27 the wedge 20 is in position to be engaged by the positive wedge 21 for throwing the clutch members into engagement; and when the plunger rests in the upper hole 28 the wedge 20 is withdrawn from position to be acted upon by the positive wedge so that manipulation of the latter is prevented from effecting the clutching operation. This provision is made for the purpose of permitting brake shoes, as hereinafter described, to release the shaft without at the same time engaging the clutch, thus leaving the shaft free to be rotated by hand, if desired, independently of the drive from the belt pulley.

The positive wedge 21 is bifurcated similarly to the negative wedge 20 and, adjacent to the latter, straddles the block 19, the inclined edges of the two wedges resting in contact with each other. For reasons to be explained, the wedge 21 can move in a vertical path only; and consequently (assuming that the plunger 26 rests in the lower hole 27 as in the drawings) when said wedge 21 is elevated, it forces the negative wedge 20 toward the right in Fig. 1. The latter, acting upon the wings 23 of block 19, moves the latter with it so that the ring 18 and clutch member 15 are also moved, all in opposition to the spring 16, and thereby the clutch is engaged. The wedge 21 is moved in its vertical path by a clutch-controlling rod 29 rigidly connected at its lower end to a treadle rod 30 which is held normally depressed in a well-known manner by a spring 31. Thus, it will be observed, the spring 31 holds the positive wedge normally in its lowermost position permitting the spring 16 to hold the parts unclutched; and when the rod 30 is elevated by treadle or other controller the clutch is engaged.

Referring to Fig. 3, the sleeve 13 terminates adjacent the inner end of the block 19 and nearby a brake drum 32 is fixed on the shaft 10. The hub of the brake drum 32 on the left in Fig. 3 abuts against a boss on the frame 11 which holds said hub against movement in that direction. Axially countersunk in the opposite end of the brake drum hub is a hardened annulus 33, separated by a ball bearing from a second exterior annulus 34, against which bear the sleeve 13, the block 19 and the positive wedge 21. Thus the wedge 21 is supported against and guided in its vertical path by an axially

stationary surface supplied by the annulus 34; and the same rigid surface limits the action of the unclutching spring 16 communicated through the various intervening parts. At the same time the ball bearing (Fig. 3) permits easy relative rotation of the brake drum 32 and the then stationary parts when the shaft is being driven.

Referring to Fig. 2, integral with the vertically movable positive wedge 21 and extending above it, is a yoke 35 slotted at its upper end to receive the stud 36 of a cam roll 37 which is held against the surface of a brake cam 38 secured (see Fig. 3) to the hub of the brake drum 32. The cam roll 37 is held in engagement with the cam 38 through the agency of the spring 31 tending always to depress the clutch controlling rod 29 and all parts connected to it. The stud shaft 36 is vertically adjustable in the slotted end of the yoke 35.

As shown in Fig. 2, the cam 38 has a clutch releasing depression 39, the remainder of the cam constituting a dwell of uniform radius. When the cam roll 37 rests in the depression 39, the positive wedge 21 is free to be depressed by the spring 31 so as to disengage the clutch member, but when the cam roll is in contact with the dwell of the cam the wedge 21 is maintained in its elevated position and unclutching is thereby prevented. The depression 39 on the cam 38 is so disposed on the shaft that it engages the cam roll 37 when the acting parts of the machine actuated by the shaft 10 have assumed the positions which they are desired to occupy when the machine is at rest. Hence, whenever the machine parts reach such positions the cam 38 stands in position to permit the unclutching of the machine whereas at all other times the cam 38 prevents unclutching. Obviously the arrival of the depression 39 of the cam 38 in position to permit depression of the cam roll 37, will not result in unclutching so long as the operator, by means of his treadle or other control opposes the spring 31 and holds the rod 30 and clutch control rod 29 in their elevated position. If, however, the spring 31 be unopposed, the clutch members will be disengaged whenever the depression 39 of the cam 38 reaches the position shown in Fig. 2.

In the manner just described this invention contemplates a prompt disengagement of the clutch members upon the instant that the shaft assumes the position it is desired to have when at rest. In most machines, however, mere unclutching at such a time is insufficient since the momentum of the machine is likely to carry the parts a considerable distance after the direct drive has ceased. To prevent this overthrow there is provided a brake mechanism such as to arrest the rotation of the shaft, preferably at once when the latter has been unclutched

from the belt pulley. This brake mechanism acts upon the brake drum 32 which is fixed upon the shaft 10 and comprises oppositely disposed brake shoes 40 and 41.

5 The illustrative arrangement of brake shoes shown in the drawings is particularly effective. Said shoes are disposed diametrically oppositely with relation to the brake drum 32 and are carried upon a brake supporting arm 42. The middle portion of the arm 42 is bifurcated and straddles the annulus 34 on the shaft 10. Said bifurcations permit the arm a slight amount of endwise play. The arm 42 is non-rotatably supported in brackets 43—43 projected from the frame 11 and is arranged to slide endwise in these brackets. The brake shoe 40 is pivoted near the upper end of the arm 42 and is freely movable on said pivot to permit it to adjust itself to the periphery of the brake drum 32 when pressed thereagainst, thus providing for the utilization of the entire braking surface of the shoe. The brake shoe 41 is mounted by its concave cylindrical hub 44 upon a stud 45, constituting one arm of a bell crank lever pivoted on the lower end of the brake arm 42 (Fig. 2). The axis of the pivot of brake shoe 40 and the axis of the stud 45 are both preferred to be parallel to the axis of rotation of the brake drum 32 and hence, both of the brake shoes are free to rock more or less in the plane of the brake drum, thus providing a pair of self-adjusting brake shoes.

35 A leaf spring 46 secured to a part of the lower bracket 43 and bearing against the lower end of the arm 42 (see Fig. 2) may be employed, normally to press said arm 42 upwardly to hold the shoe 40 out of contact with the brake drum 32.

As already explained, the stud 45 for the brake shoe 41 constitutes one arm of a bell crank lever, the center of which is at 47, Fig. 2, it being noted also that the brake shoe 40 is pivotally mounted upon the arm 42. If, now, said bell crank lever be moved clockwise, as by the arm 48, the brake shoe 41 will be raised and the brake shoe 40 correspondingly lowered into binding contact with the brake drum, such action being exercised through the toggle arrangement described, the operation being such that the points of pivotal connection between the lower brake shoe and its lever, the upper brake shoe and the brake arm and the point 47 will approach more or less into a straight alignment, thus acting as a toggle in drawing the brake shoes substantially simultaneously against diametrically opposite portions of the brake drum.

The bell crank lever, of which the stud 45 is one arm, is moved clockwise to the ends just described through the agency of its other arm 48 (Fig. 2). This arm 48 is connected by means of a ball and socket or

other suitable joint with the clutch controlling rod 29. It follows, then, that when the rod 29 is elevated the bell crank lever 45—48 is moved contra-clockwise about its center of rotation 47, thereby breaking the above described toggle, removing the shoe 41 from its breaking engagement with the drum 32 and, at the same time releasing the shoe 40 from braking pressure and permitting the spring 46 (if it be employed) to push the brake arm 42 upwardly and remove the brake shoe 40 from engagement with the drum 32. It is found in practice that if the spring 46 or its equivalent be not employed the brake shoe 40, upon the release of the shoe 41, as just described, will not maintain a sufficient engagement with the brake drum 32 to exert any material braking action thereon.

A convenient alternative or accompaniment to the spring 46, if it be desired to employ some such expedient for lifting the shoe 40, may be supplied by extending a portion of the bell crank lever 45—48 in a finger 49 (see Fig. 2), arranged to strike against a stop 50 on the lower bracket 43 when the lever 45—48 is moved contra-clockwise in Fig. 1. An adjustable stop screw 51 may be fixed in the finger 49, to vary the time in the movement of the lever 45—48 when the finger shall contact with the stop 50. With this arrangement when the finger 49 strikes the stop 50, continued rotation of the lever 45—48 will serve to elevate the arm 42 and lift the upper shoe 40, while at the same time the lower shoe will be withdrawn from engagement with the brake drum. While the spring 46, and the finger 49 and stop 50 are shown as used together on the same machine, it is to be understood that they may be used separately. In fact, practice has demonstrated that neither is essential though, perhaps, desirable. The finger 49 and stop 50 are omitted from Fig. 1.

Referring to Figs. 1 and 2, the stud 45 to which the lower brake shoe 41 is pivoted, is integral with a split sleeve clamped upon the hub of the other arm 48 of the bell crank lever above referred to. By loosening this split sleeve it may be rotated on the hub of the arm 48 and thereby adjusted to compensate for wear or for other purposes and said sleeve may then be clamped in adjusted position.

To summarize, the operation of the specific illustrative form of starting and stopping mechanism is as follows, to wit: The machine stands normally at rest and is so shown in the drawings. At such a time the rod 30 and the clutch controlling rod 29 occupy their lowermost positions to which they are depressed by the spring 31; and also the cam roll 37 rests in engagement with the clutch releasing depression 39 on

the cam 38. The brake shoes are in engagement with the brake drum, and, of course, the machine is unclutched. If, under these conditions the rod 30 be elevated, as by a
 5 treadle, against the tension of the spring 31, the rod 29 and the wedge 21 will be forced upwardly, thereby moving the wedge 20 to the right in Fig. 1 and throwing the clutch member 15 into driving engagement with
 10 the clutch member 12, whereupon the shaft 10 will be rotated. Simultaneously with the elevation of the rod 29 the cam roll 37 is lifted out of the depression 39 in the cam 38, and also the bell crank lever 45-48 is rotated
 15 contra-clockwise to withdraw the brake shoes from braking engagement with the drum, leaving the latter free to rotate with the shaft 10. The rotation of the shaft, and whatever machine may be driven
 20 thereby, will continue uninterruptedly until the treadle or other controller is released, permitting the rod 30 to be again depressed by the spring 31. If at the moment of this release it should happen that the depression
 25 39 of the cam 38 is in position to receive the then descending roll 37, the machine would be immediately unclutched and the brakes applied. In the great majority of instances, however, when the roll 37 descends it will
 30 strike some portion of the dwell of the cam 38, the latter as already described preventing unclutching by holding the roll 37 in elevated position. When, however, during the rotation of said cam the depression 39
 35 reaches the position shown in Fig. 2 the spring 31 is permitted to depress the rod 30, thereby withdrawing the wedge 21 permitting the spring 16 to unclutch the machine, rocking the bell crank lever 45-48 clock-
 40 wise in Fig. 2, and thereby, by its strong toggle movement, forcing the brake shoes into firm and effective engagement with the brake drum 32.

It is understood, of course, that the operations just described as ensuing after the entrance of the roll 37 into the cam depression 39 are performed in the specific mechanism described substantially instantaneously, so that the brake drum 32 is forcibly,
 50 gripped between the brake shoes almost upon the instant that the roll 37 enters the depression 39.

If, at any time, it be desired to turn the shaft 10 by hand or otherwise independently of the direct drive from the belt pulley, it is desirable that concurrently the clutch be disengaged and the brakes inactive, leaving the shaft entirely free. In the operation of the machine as just described, this state of affairs will not normally occur but it may be readily instituted by vertically adjusting the negative wedge
 60 in the manner already described and thereafter elevating the rod 30 so as to disengage the brakes. Vertical adjustment of

the negative wedge 20 renders impossible, for the time being, the engagement of the clutch members by the elevation of the positive wedge 21 and consequently the elevation of the latter which accompanies the un-
 70 braking is idle as to any effect upon the shaft which is then both unclutched and unbraked and may be turned at will. This condition will continue so long as the rod 30 is maintained in its elevated position and
 75 even after said rod has been released from its elevating influence if at that time the cam roll 37 be in engagement with the dwell of the cam 38. When, however, said cam roll enters into engagement with the clutch
 80 releasing depression 39 on the cam the brakes will be set and further rotation of the shaft will be prevented. In this manner the stopping position of the shaft whether it be rotated by hand or mechanically is definitely
 85 determined since the brakes will not at any time be applied except the shaft be in position determined by engagement of the cam roll 37 and the clutch releasing depression 39 of the cam 38.

For lubricating purposes, the block 19 is provided with a cup 52, to contain oily waste, oil or the like, which communicates by an outlet with the interior of the block
 95 adjacent the exterior of the sleeve 13. The periphery of said sleeve has one or more longitudinal grooves 53 which carry oil throughout the length of the sleeve; and these grooves have outlets communicating
 100 with the interior of the sleeve where they deliver lubricant to the shaft 10. With this arrangement all the bearing surfaces of rotating parts are kept well lubricated to contribute to the easy operation of the mechanism.

It is found in practice that the arrangement of brake shoes and drums contemplated by this invention as defined in the claims is so promptly and accurately effective
 110 as to avoid any necessity for a positive stop such as is sometimes employed in the form of an abutment against which some rotating part impacts when it is desired to arrest said part and the machine. This being the case, the preferred mechanism shown in the drawings employs no positive stop whatever. It
 115 is to be understood, however, that the employment of a positive stop in connection with any feature of this invention would not remove such feature from the proper
 120 scope of the subjoined claims.

A further feature of decided advantage results from the preferred cooperation of the roll 37 and cam 38 which is illustrated in the drawings. It will be observed that
 125 the cam 38 acts upon the clutch controlling rod 29 along substantially the same line in which the spring 31 tends to move said rod. That is to say, when the spring 31 is ready to act and the roll 37 rests upon the
 130

dwelt of the cam 38, said cam opposes the action of said spring in substantially the line of its impulse; and when the roll enters the depression 39 in the cam and the rod 29 is abandoned to the action of the spring, the space of time intervening between the release of the roll and the communication of said release to the spring is minimized, permitting the spring to act substantially instantaneously and to effect the unclutching and stopping of the machine always promptly at the desired time. This advantage accrues mainly from the fact that this invention contemplates the elimination of all levers and the like, such as are commonly employed, intervening between the spring or other unclutching agency and the stop motion controlling cam which require a multiplication of motions to occur before the release afforded by the cam can be communicated to the spring or its equivalent.

Various advantages, other than those pointed out, are supplied by this invention; and they will be apparent to those familiar with the art. Also many changes possible to be made in the above described illustrative mechanism will appear to those familiar with the art. For example, in connection with a brake mechanism such as is contemplated by this invention it might be practicable to employ various types of clutch mechanisms and, accordingly, the invention is not to be restricted in its application to use in connection with a clutch of the type or construction disclosed. Moreover, the details of construction of the brake mechanism are not to be considered as essential.

Such mechanical alterations and modifications as are here alluded to are to be construed as included within the proper scope of the invention as it is defined in the subjoined claims.

I claim:

1. A starting and stopping mechanism having, in combination, a driving member; a driven member; a plurality of brake shoes disposed diametrically of and to act on the driven member; a brake arm extending diametrically of the driven member and carrying said brake shoes; actuating means for the brake shoes including said brake arm; and clutch operating mechanism controlling said actuating means.

2. A starting and stopping mechanism having, in combination, a driving member; a driven member; a plurality of brake shoes to act on the driven member; a diametrically disposed arm carrying said brake shoes; actuating means for the brake shoes including said arm; clutch mechanism; and stop motion controlling means controlling both the brake shoes and the clutch mechanism.

3. A starting and stopping mechanism having, in combination, a driving member; a

driven member; clutch mechanism; a brake drum; an arm diametrically disposed with relation to the drum; self-adjusting brake shoes connected to the arm; means including said arm to set and disengage one shoe, and by moving the arm to set the other shoe; and additional means acting when the first shoe is disengaged to move the arm and disengage the other shoe.

4. A starting and stopping mechanism having, in combination, a driving member; a driven member; clutch mechanism; a brake drum; brake shoes; an arm extending diametrically of the driven member for supporting the shoes at opposite sides of the driven member; a lever pivoted to the arm; a pivotal connection between the lever and one brake shoe; and means for adjusting said pivotal connection with relation to the lever.

5. A starting and stopping mechanism having, in combination, a driving member; a driven member; a clutch; cooperating wedges to operate the clutch; means to move one wedge for controlling the clutch; means to adjust another wedge to interrupt said control; and brake mechanism operable concurrently with movement of the first mentioned wedge.

6. A starting and stopping mechanism having, in combination, driving and driven members; a clutch to operatively connect the driving and driven members; wedges 20 and 21 for operating the clutch; a rod 29 connected to one of said wedges; a finger 22 having holes; and a device 26 to engage any one of said holes.

7. A starting and stopping mechanism, having, in combination, driving and driven members; clutch mechanism for connecting and disconnecting the driving and driven members; an arm 42 extending diametrically of the driven member; a drum 32; shoes 40 and 41 carried at opposite ends of said arm; brackets 43; and a lever 45-48 mounted on said diametrically extending arm.

8. A starting and stopping mechanism having, in combination, driving and driven members; clutch mechanism for connecting and disconnecting said members; a drum 32 movable in unison with the driven member; shoes 40 and 41 disposed about said drum to act thereon; an arm 42 carrying said shoes; and means for moving the said arm endwise in opposite directions.

9. A starting and stopping mechanism having, in combination, driving and driven members; clutch mechanism; a block 19 having wings 23; and wedges 20 and 21 one of which acts upon said wings, and both of said wedges having portions embracing and guided by said block.

10. A starting and stopping mechanism having, in combination, a shaft; a sleeve on the shaft; a clutch comprising fast and

loose clutch members; a block 19 on the sleeve having projecting wing portions; a pair of relatively movable wedges embracing said block, one of which wedges bears
5 against said projecting wings; and means for relatively moving said wedges to operate the clutch.

In testimony whereof, I have signed my name to this specification, in the presence of two subscribing witnesses.

MERTON D. PHELAN.

Witnesses:

FREDERICK L. EMERY,
LAURENCE A. JANNEY.