



US00RE38311E

(19) **United States**  
(12) **Reissued Patent**  
**Wheeler**

(10) **Patent Number:** **US RE38,311 E**  
(45) **Date of Reissued Patent:** **Nov. 11, 2003**

(54) **HIGH-DENSITY CABLE DISTRIBUTION FRAME**

5,353,367 A	10/1994	Czosnowski et al.	
5,363,467 A	* 11/1994	Keith .....	385/135
5,402,515 A	3/1995	Vidacovich et al.	
5,490,229 A	2/1996	Ghandeharizadeh et al.	
5,511,144 A	* 4/1996	Hawkins et al. ....	385/135
5,570,450 A	10/1996	Fernandez et al.	

(75) Inventor: **Todd A. Wheeler**, Savage, MN (US)

(73) Assignee: **ADC Telecommunications, Inc.**, Eden Prairie, MN (US)

(21) Appl. No.: **09/035,377**  
(22) Filed: **Mar. 5, 1998**

**Related U.S. Patent Documents**

Reissue of:

(64) Patent No.: **5,497,444**  
Issued: **Mar. 5, 1996**  
Appl. No.: **08/446,428**  
Filed: **May 22, 1995**

U.S. Applications:

(63) Continuation of application No. 08/180,970, filed on Jan. 21, 1994, now abandoned.

(51) **Int. Cl.**<sup>7</sup> ..... **G02B 6/44**  
(52) **U.S. Cl.** ..... **385/135; 385/134; 385/59; 385/25**

(58) **Field of Search** ..... **385/135-137, 385/139, 53, 59, 25, 89**

(56) **References Cited**

**U.S. PATENT DOCUMENTS**

4,359,262 A	11/1982	Dolan	
4,502,754 A	3/1985	Kawa	
4,585,303 A	4/1986	Pinsard et al.	
4,595,255 A	6/1986	Bhatt et al.	
4,630,886 A	12/1986	Lauriello et al.	
4,699,455 A	* 10/1987	Erbe et al. ....	385/89
4,717,231 A	1/1988	Dewez et al.	
4,765,710 A	8/1988	Burmeister et al.	
4,792,203 A	12/1988	Nelson et al.	
4,986,762 A	* 1/1991	Keith .....	385/76 X
4,995,688 A	* 2/1991	Anton et al. ....	385/53
5,100,221 A	3/1992	Carney et al.	
5,129,030 A	* 7/1992	Petrunia .....	385/135
5,142,606 A	8/1992	Carney et al.	
5,167,001 A	* 11/1992	Debortoli et al. ....	385/135
5,289,558 A	* 2/1994	Teichler .....	385/135
5,335,349 A	* 8/1994	Kutsch et al. ....	385/137 X

**FOREIGN PATENT DOCUMENTS**

AU	40995/85	4/1985	
AU	8655314 A1	3/1986	
DE	3308682	* 9/1984	
EP	146478	12/1984	
EP	149250	12/1984	
EP	196102	* 10/1986	..... 385/135
EP	0406151	* 1/1991	
EP	479226	* 4/1992	..... 385/135
EP	196102 B1	3/1993	
EP	0538164	* 4/1993	
FR	2531576	* 2/1984	
FR	2587127	* 3/1987	
JP	27 35 106	8/1977	
JP	59-74523	4/1984	
JP	60-169811	9/1985	
JP	61-55607	3/1986	
JP	61-90104	* 5/1986	..... 385/135
WO	WO91/10927	* 7/1991	

**OTHER PUBLICATIONS**

Northern Telecom bulletin #91-004, Issue #2, May, 1991.\*  
AT&T product bulletin 2987D-DLH-7/89 Issue 2.\*  
"ITU Fiber Handbook", 7 pages. Mar. 1992.  
"Precision Mechanical", 3 pages.

\* cited by examiner

*Primary Examiner*—Hemang Sanghavi

(74) *Attorney, Agent, or Firm*—Merchant & Gould P.C.

(57) **ABSTRACT**

A fiber distribution frame includes a fixture having a plurality of modules mounted side-by-side within said fixture with each of the modules being individually mounted in a line of travel. Each of the modules can be locked in any one of a plurality of discrete positions within the line of travel. Each of the modules contains a plurality of adapters for receiving and retaining fiber optic connectors. Further, the fixture may be tilted downwardly to provide access to the rear of the fixture.

**30 Claims, 18 Drawing Sheets**

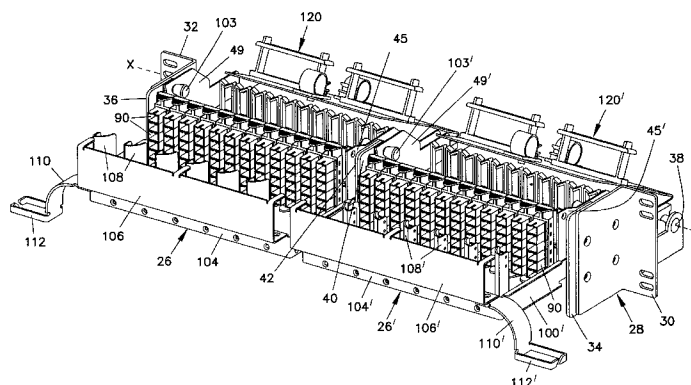

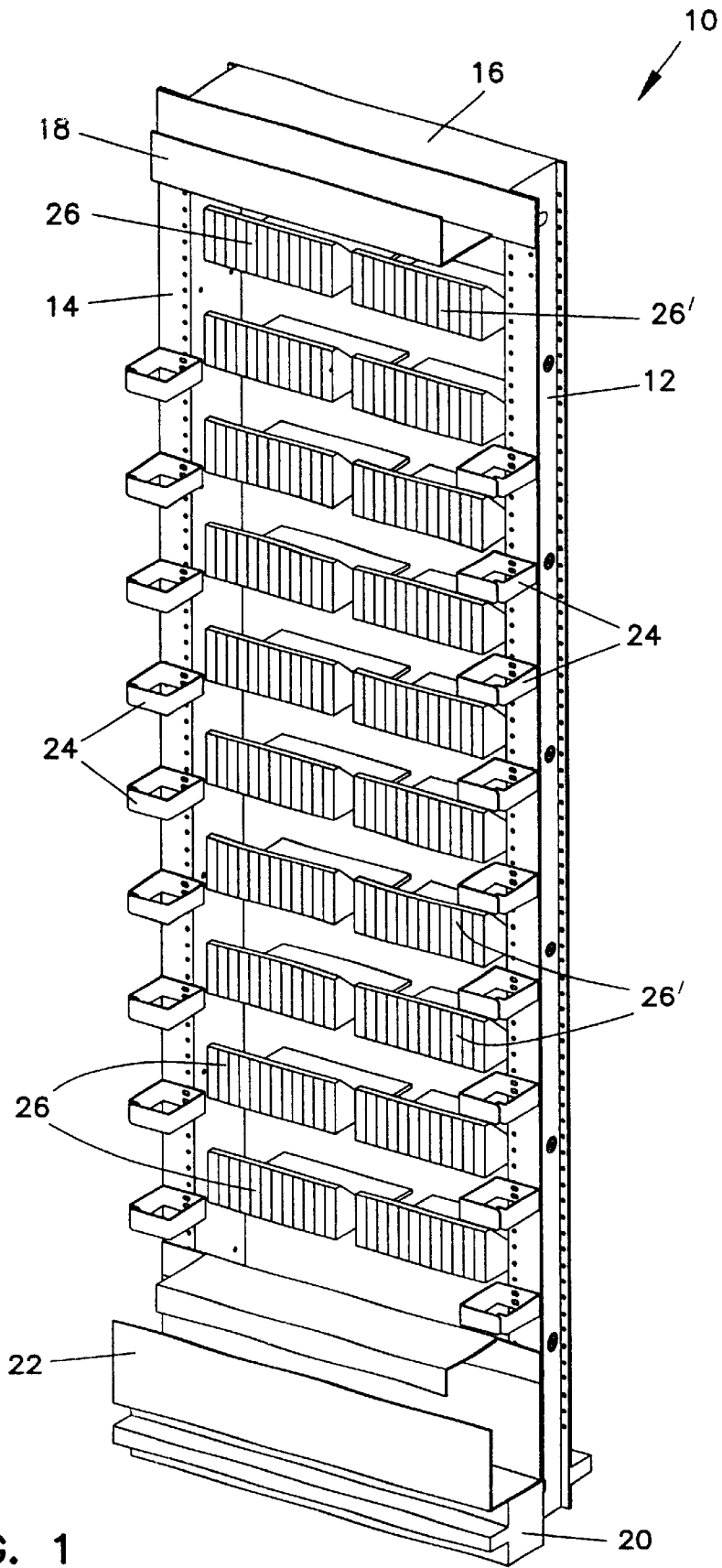

FIG. 1

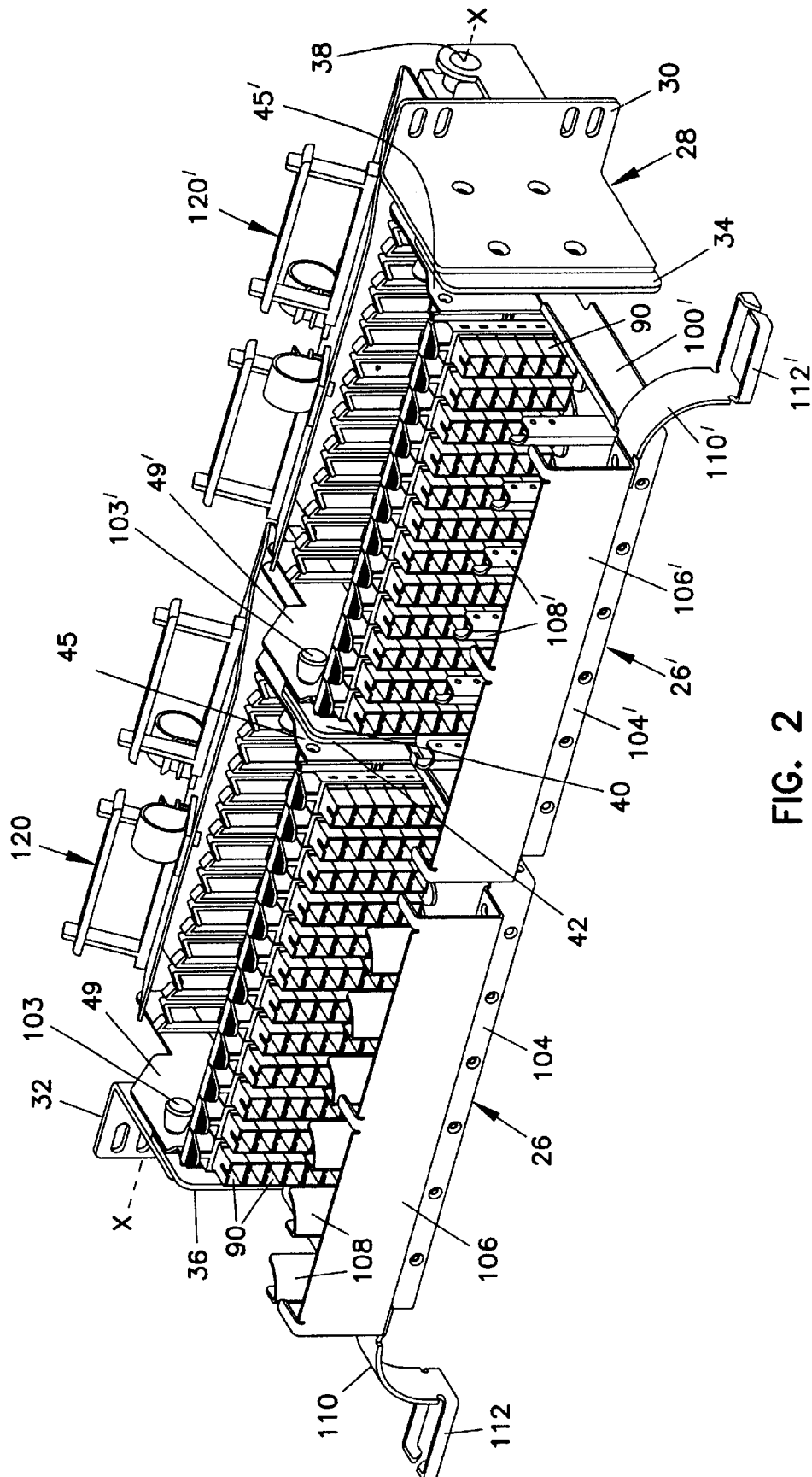

FIG. 2

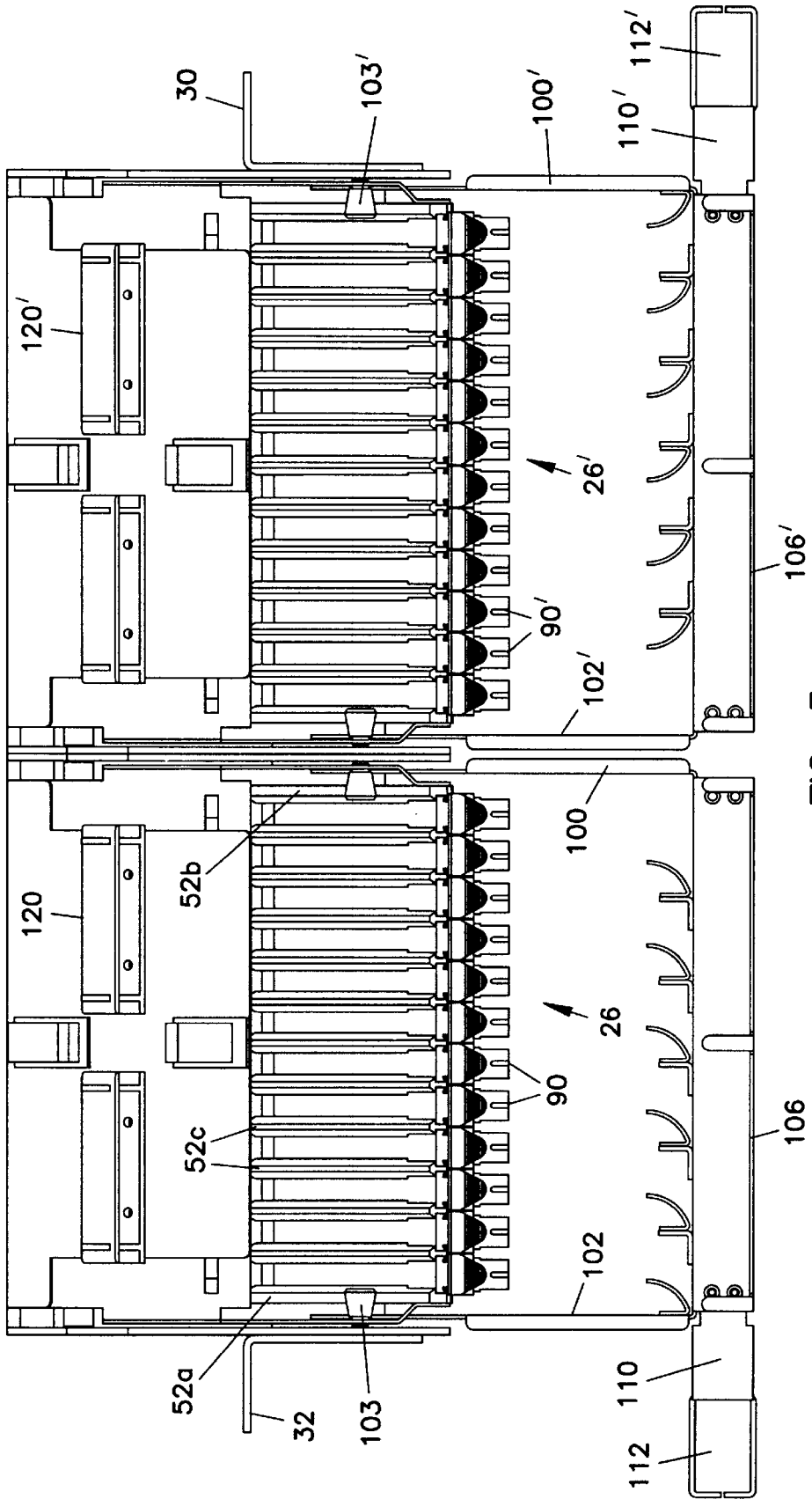

FIG. 3

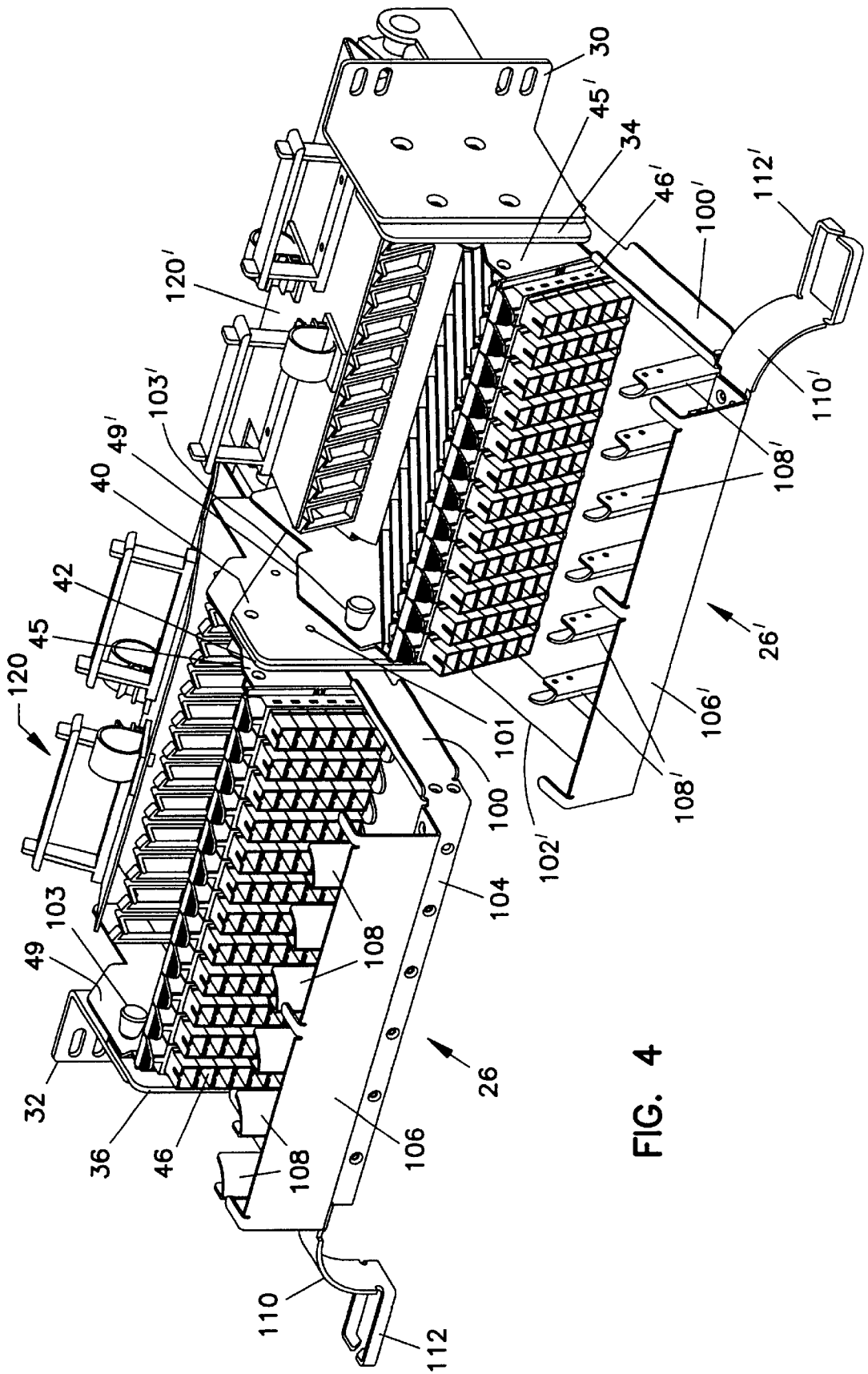

FIG. 4

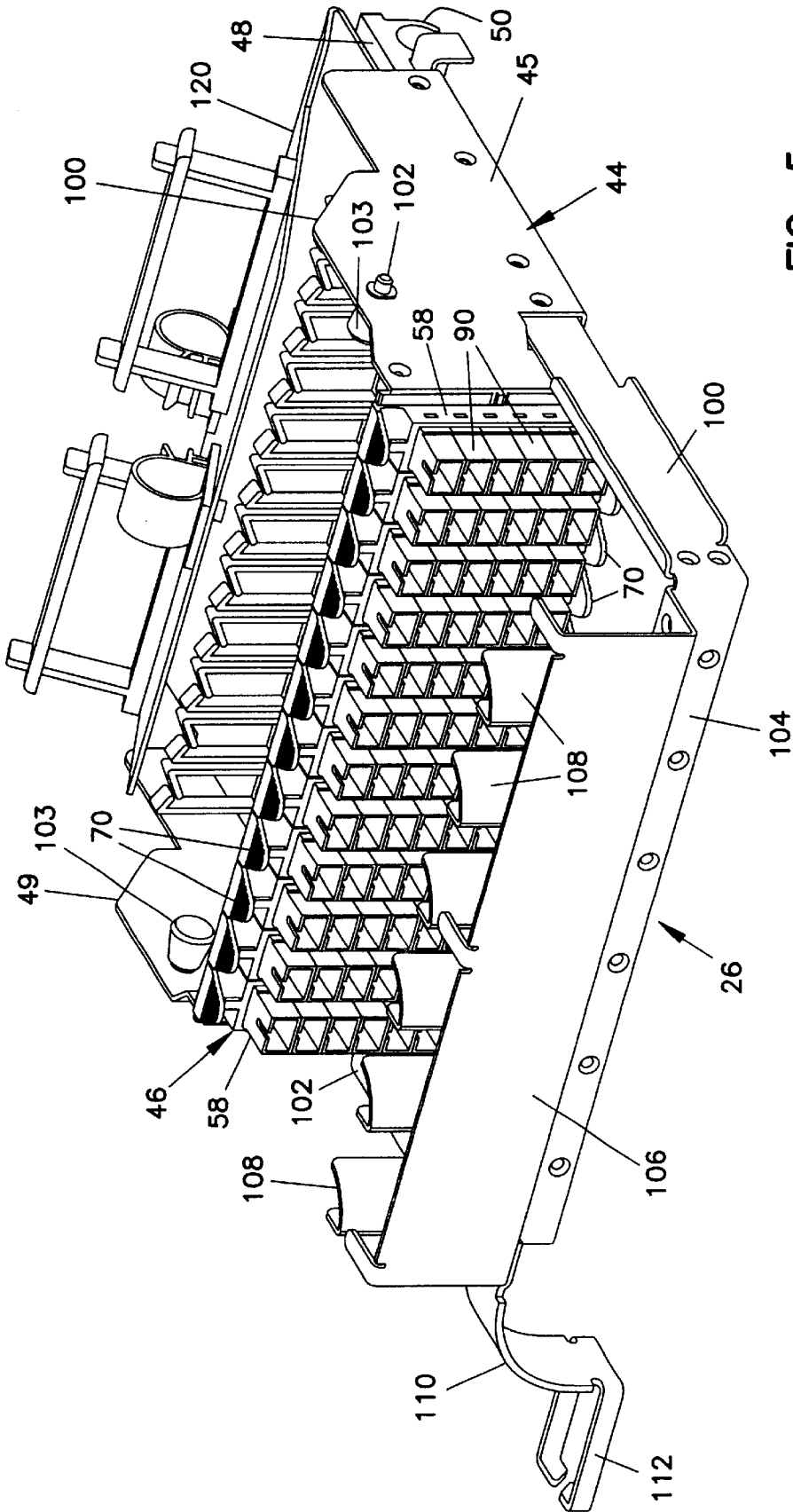

FIG. 5

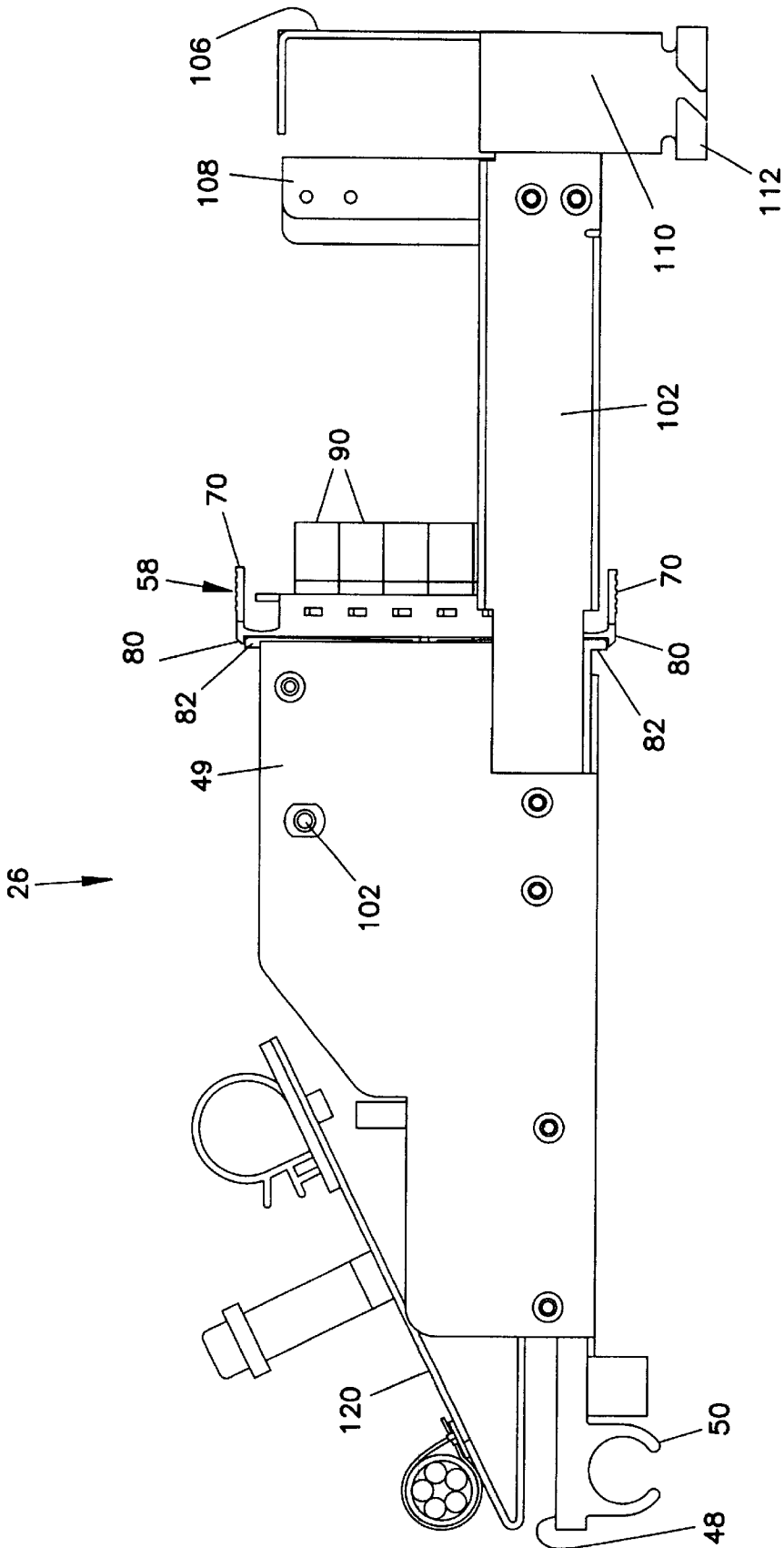

FIG. 6

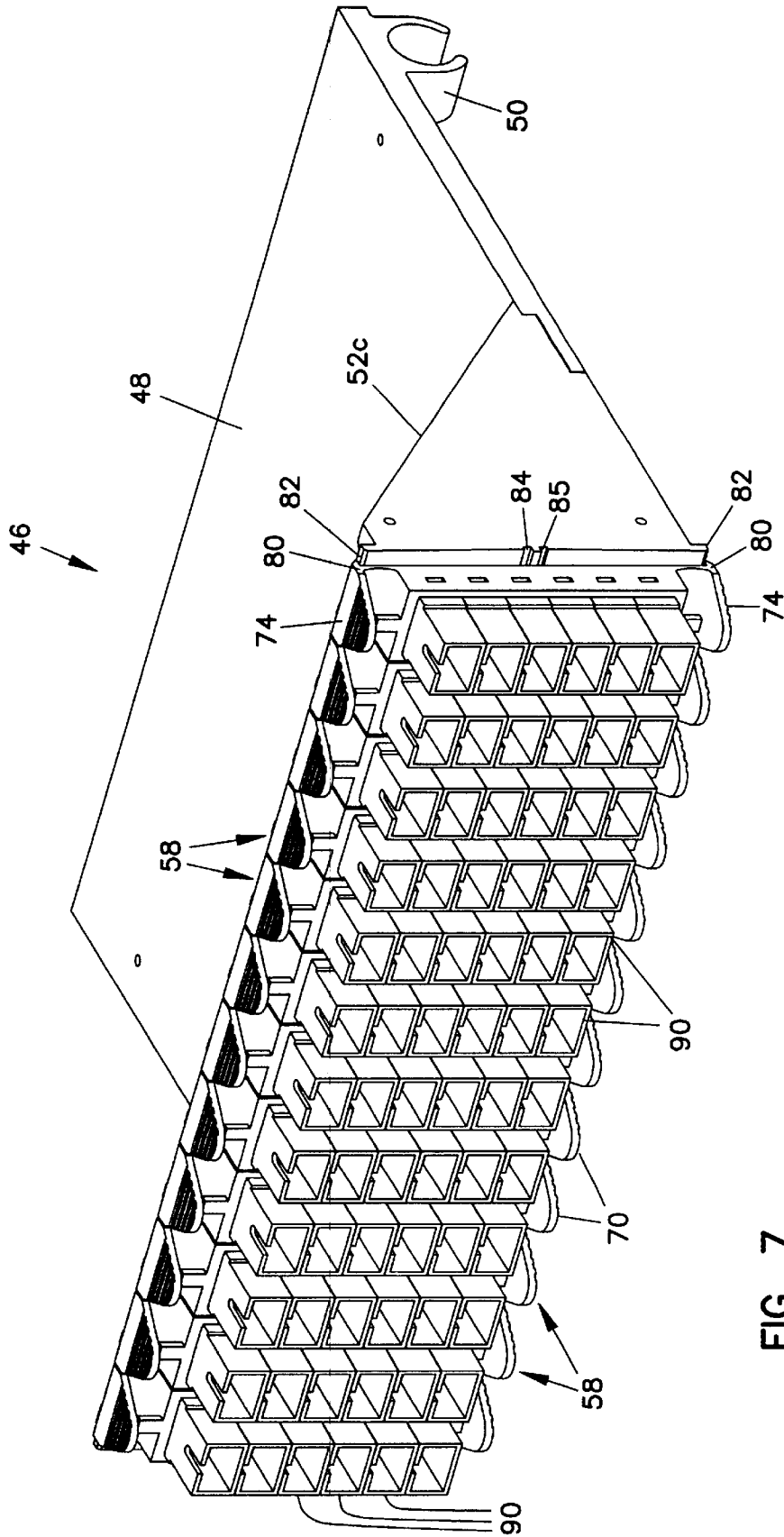

FIG. 7



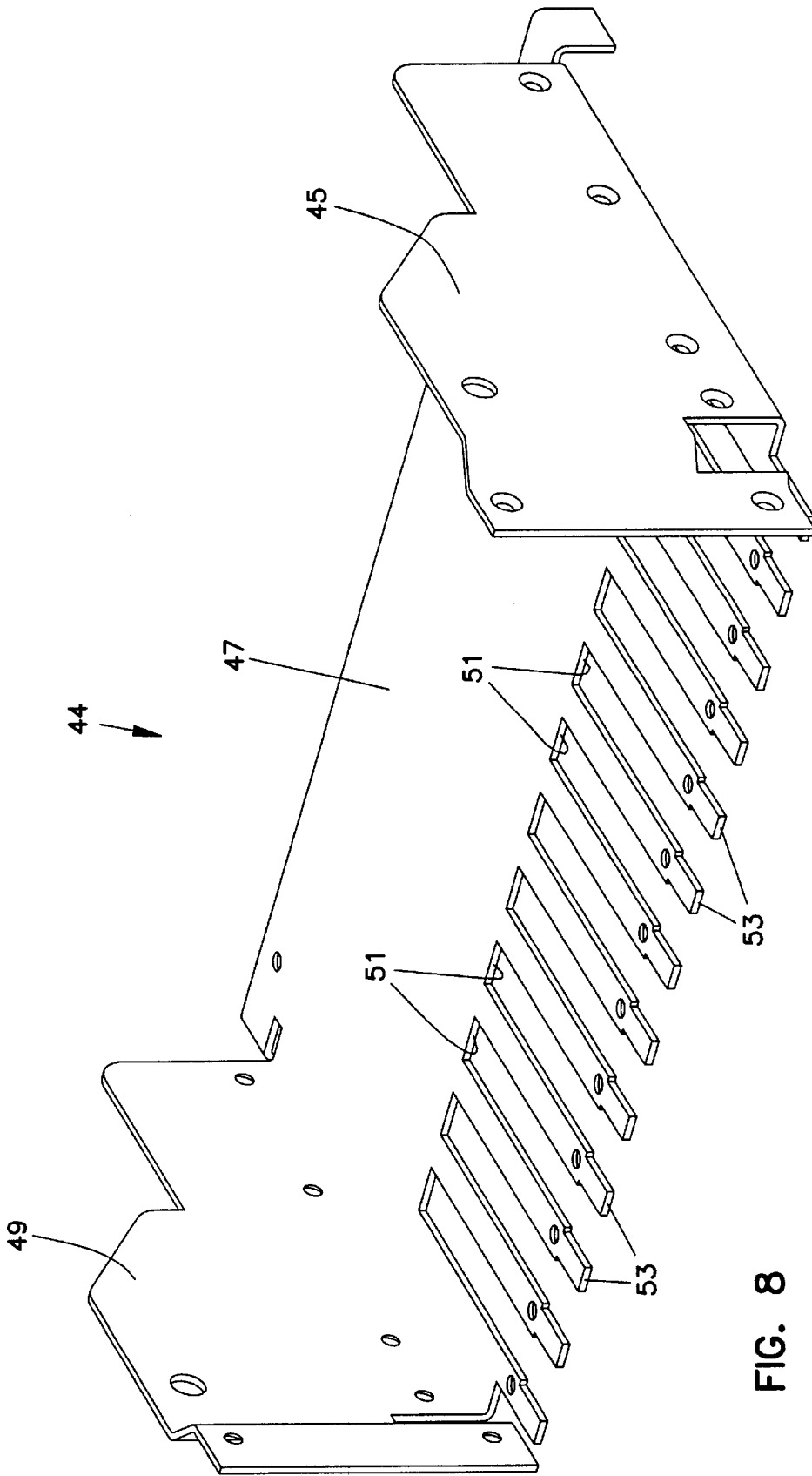

FIG. 8

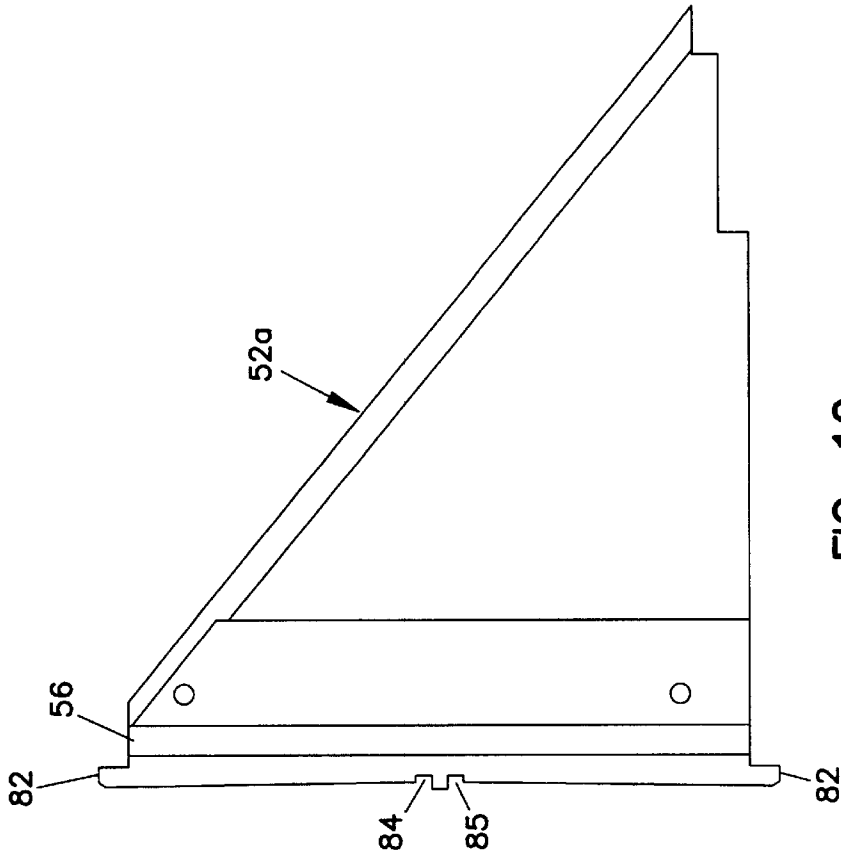

FIG. 10

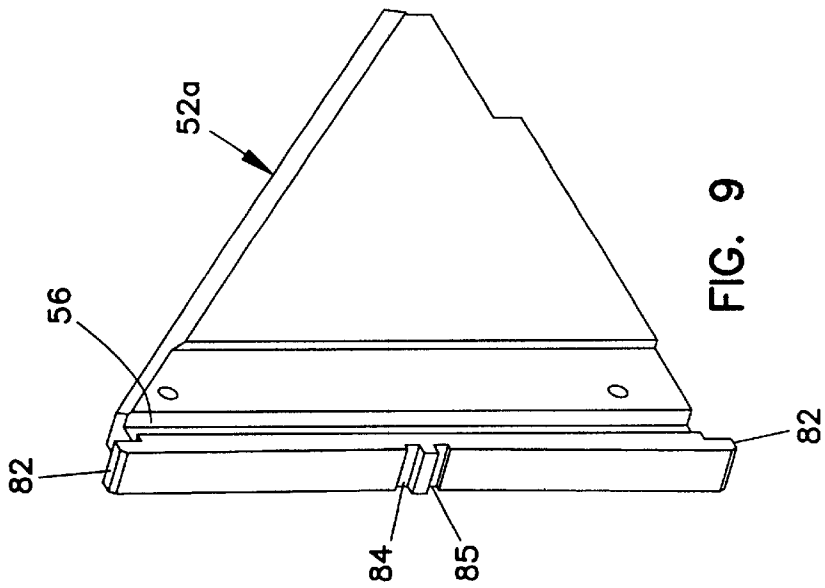

FIG. 9

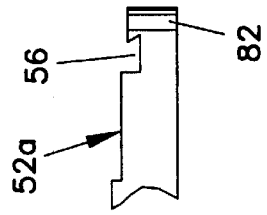
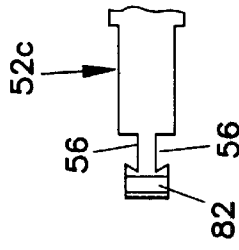
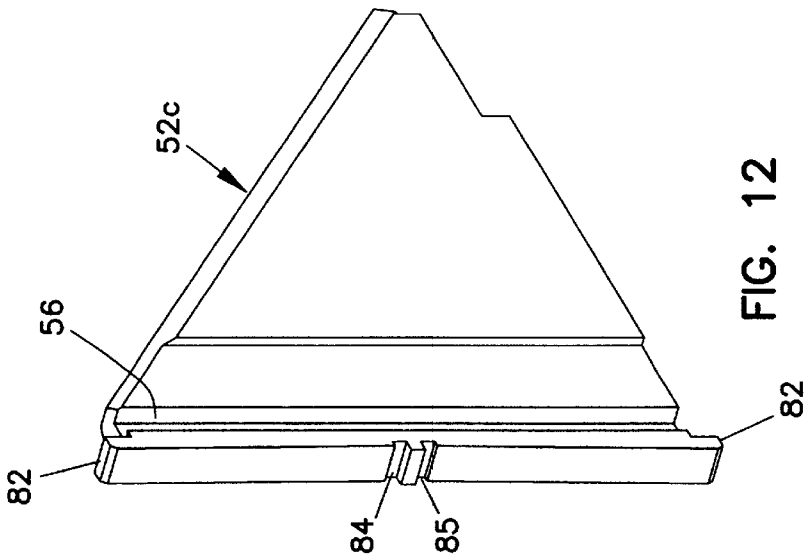
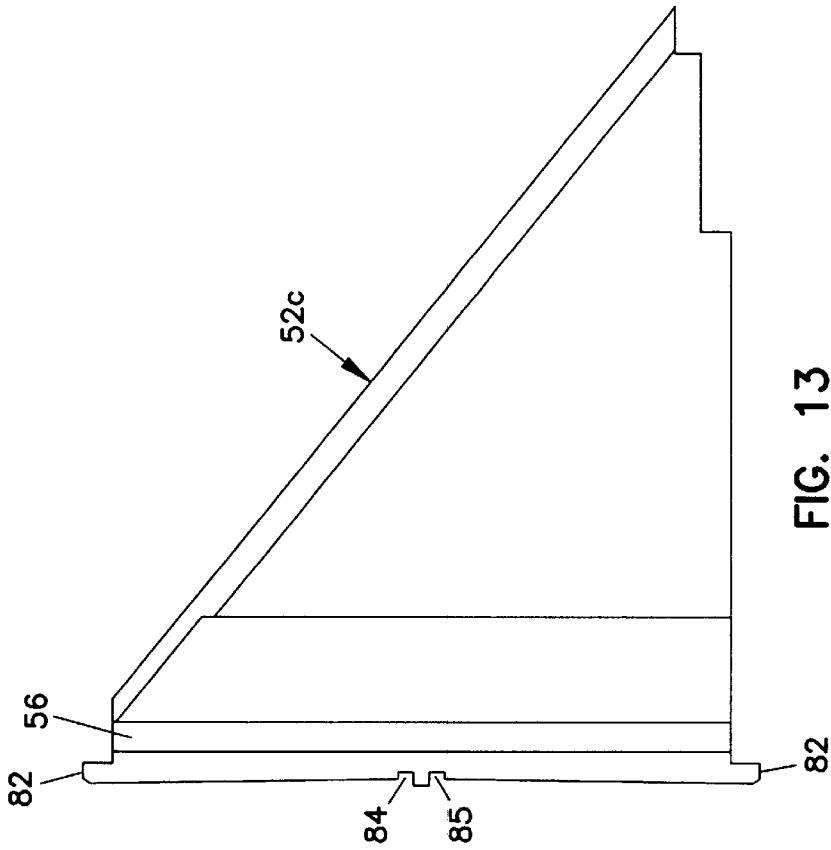

FIG. 11



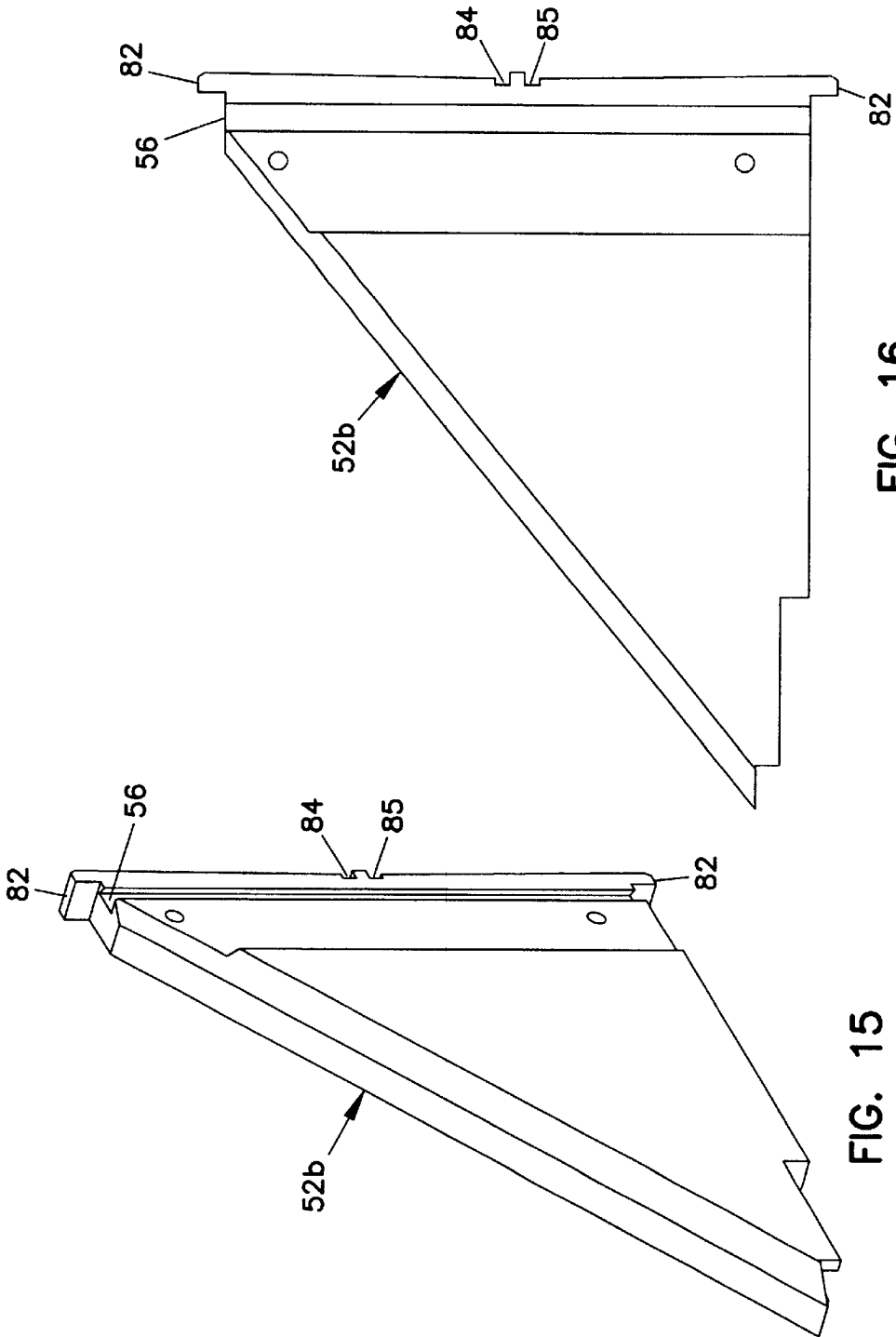

FIG. 15

FIG. 16

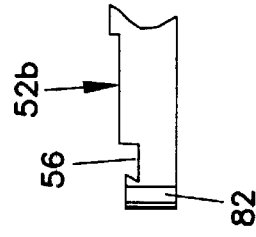

FIG. 17

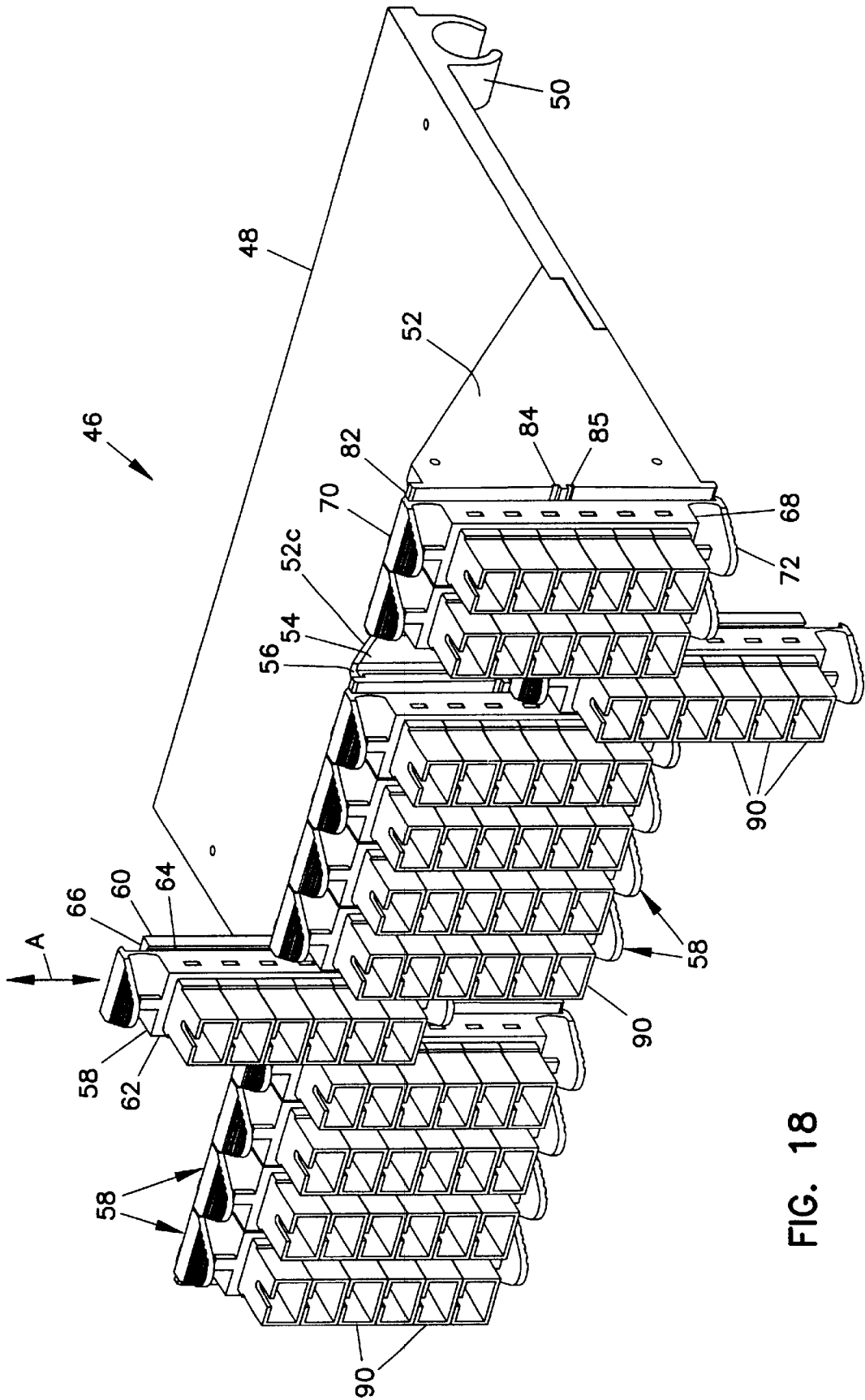

FIG. 18

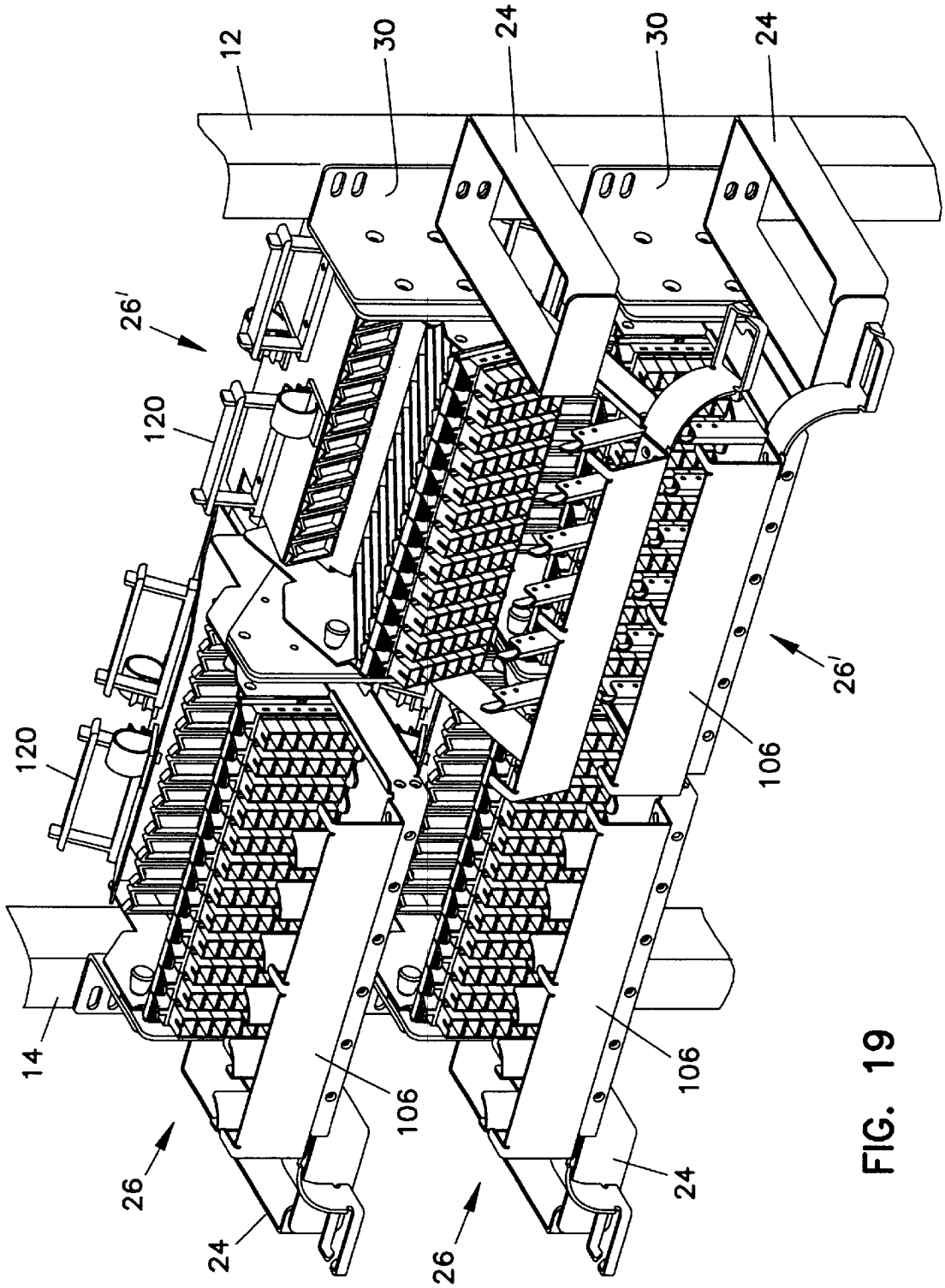

FIG. 19

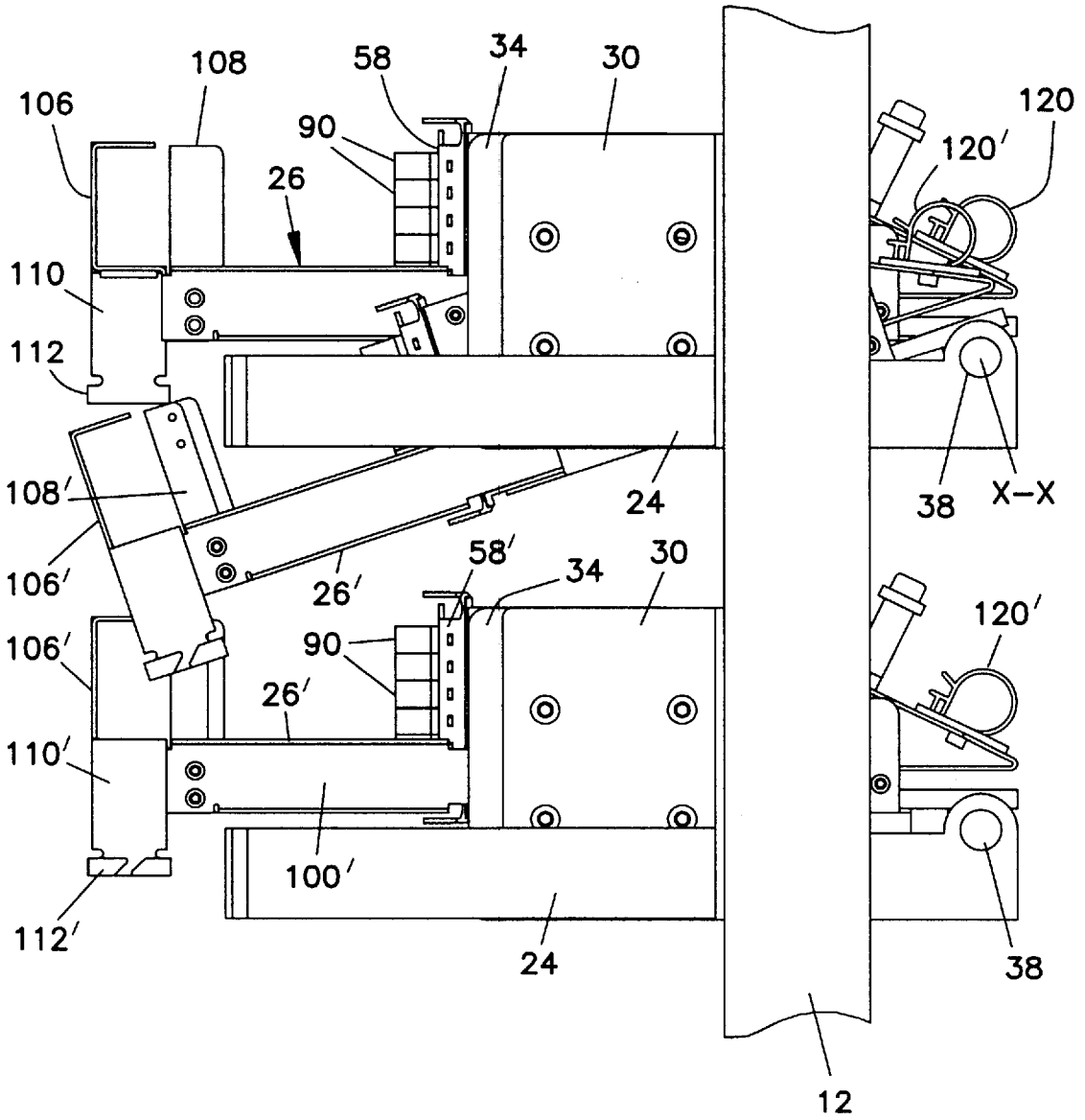

FIG. 20

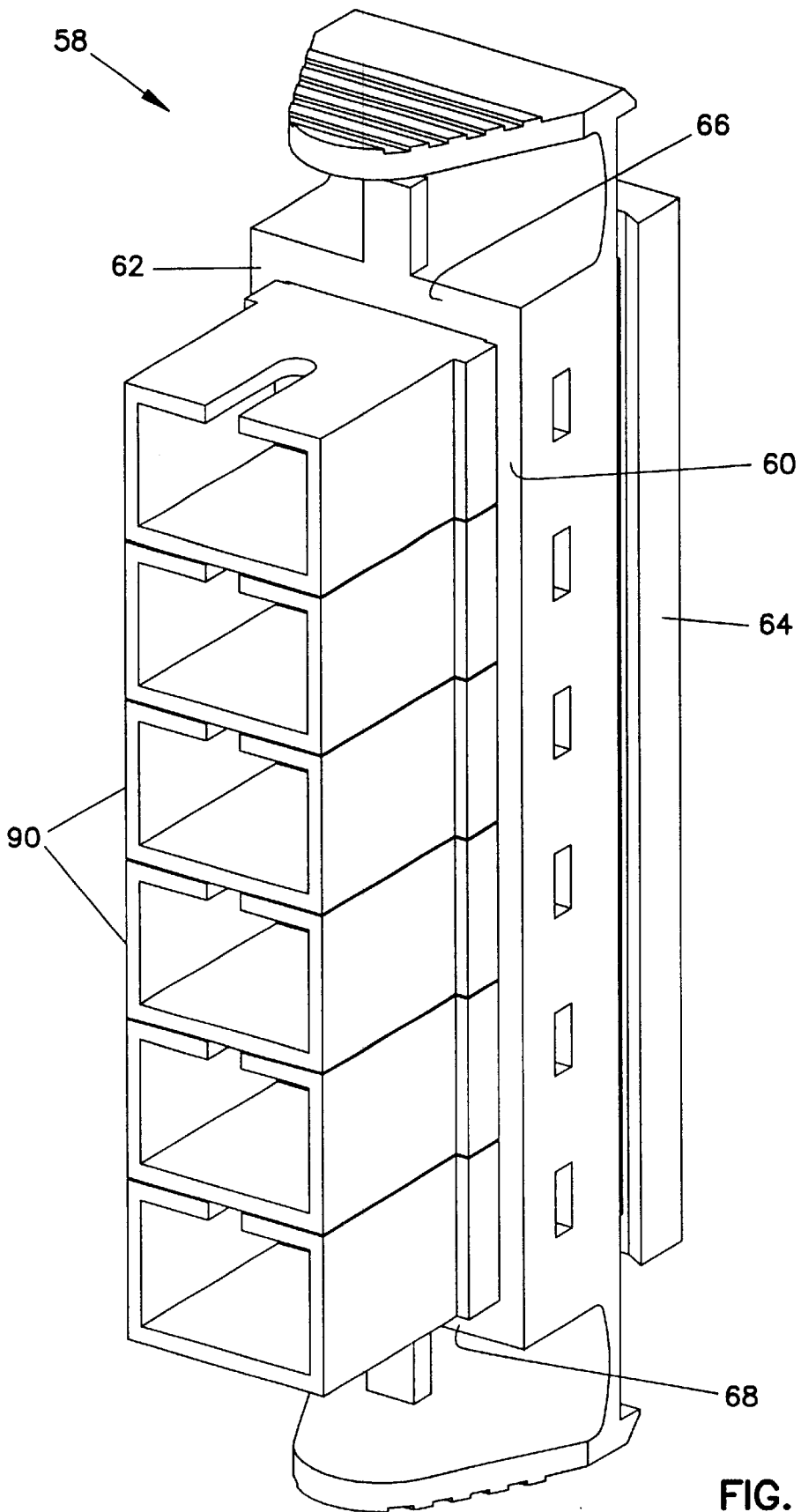

FIG. 21



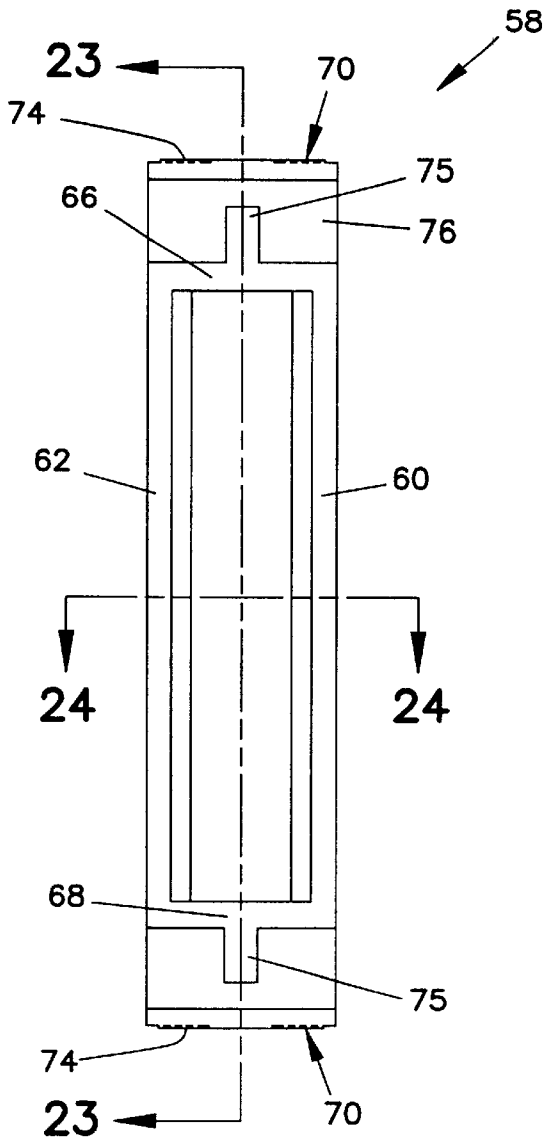

FIG. 22

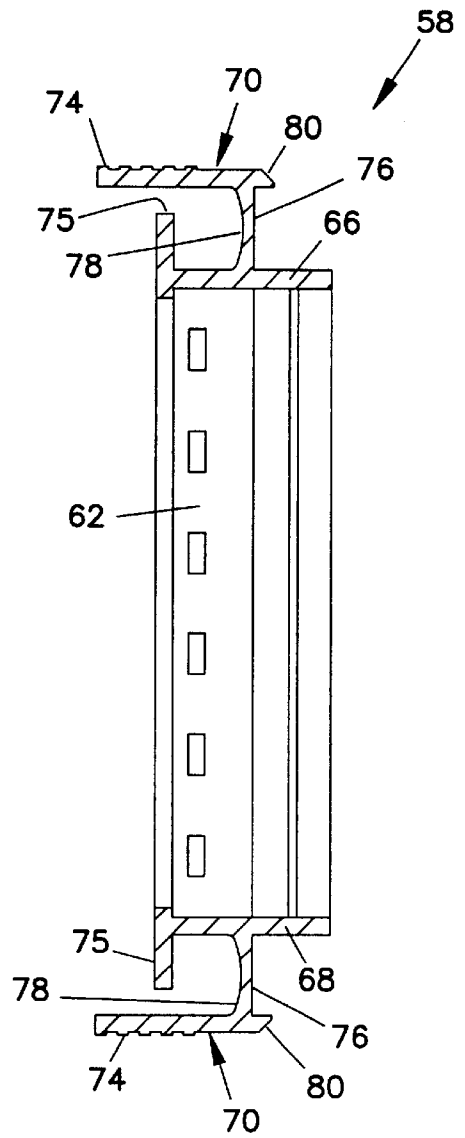

FIG. 23

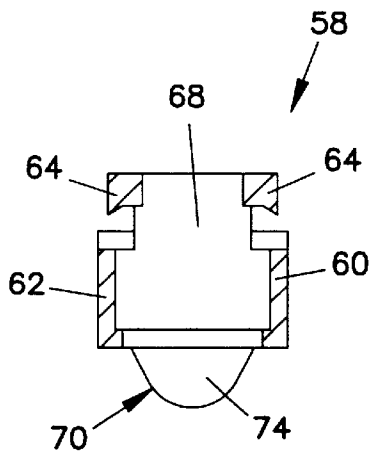

FIG. 24

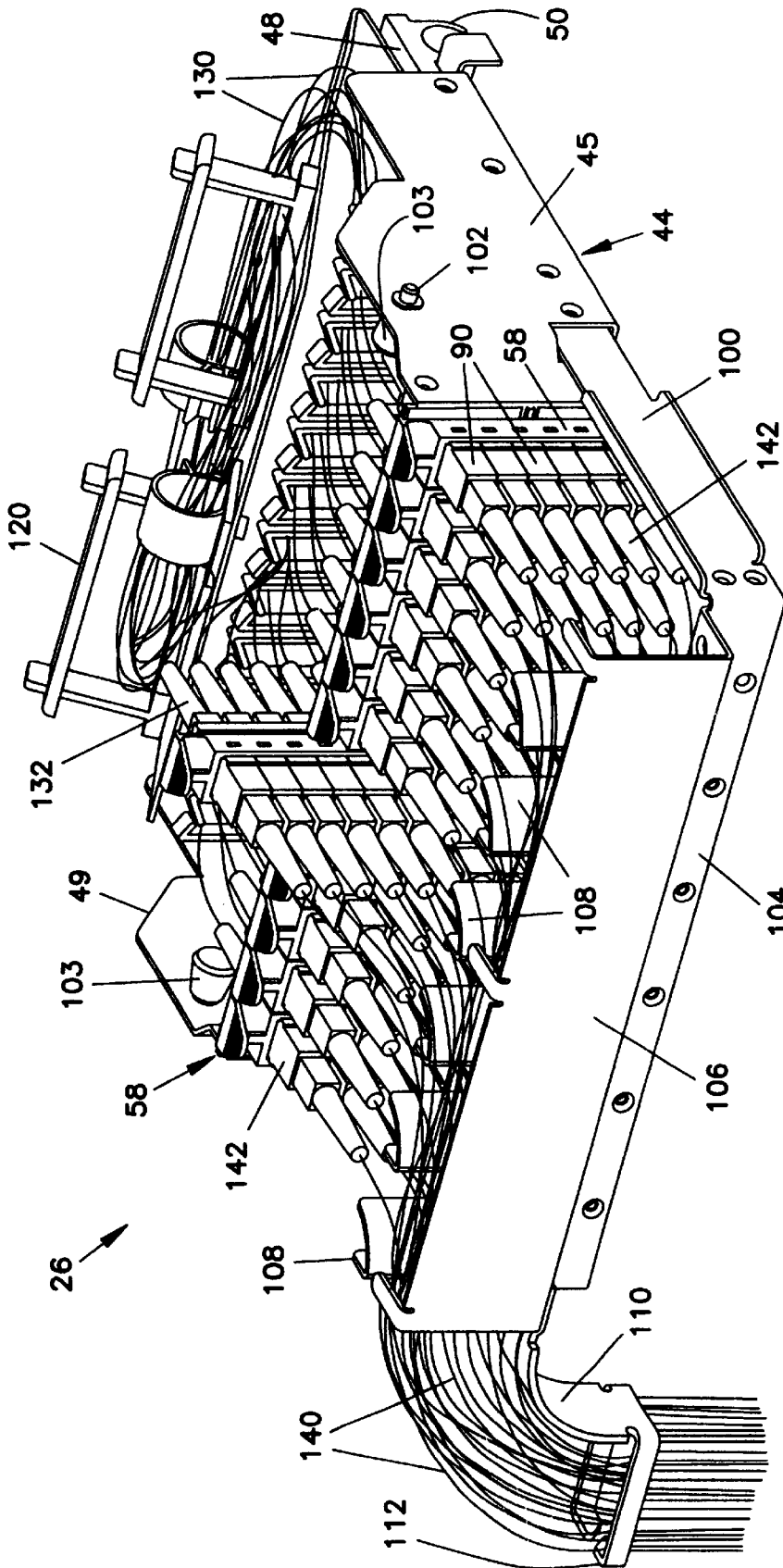

FIG. 25

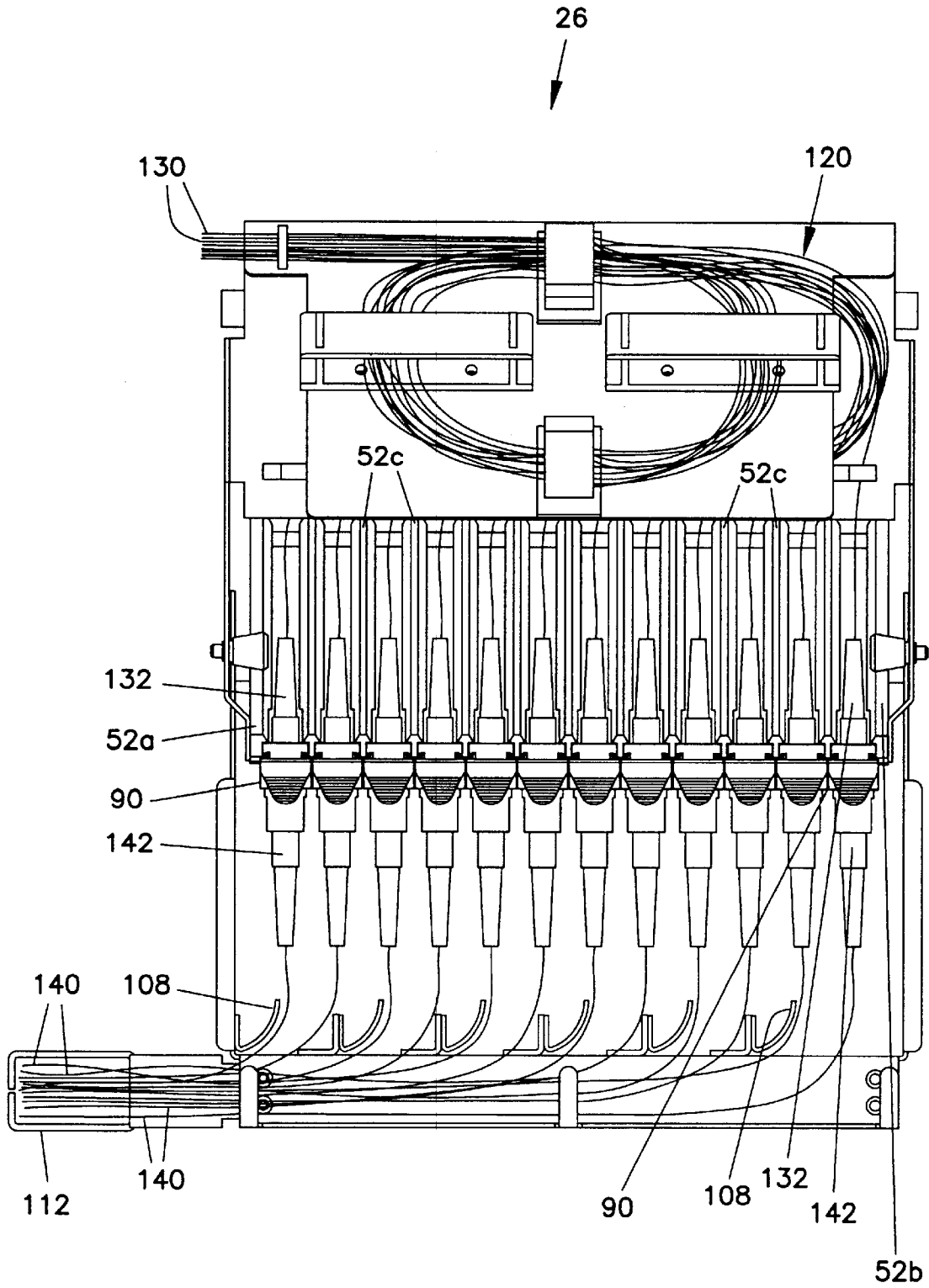

FIG. 26

## HIGH-DENSITY CABLE DISTRIBUTION FRAME

**Matter enclosed in heavy brackets [ ] appears in the original patent but forms no part of this reissue specification; matter printed in italics indicates the additions made by reissue.**

This is a continuation of application Ser. No. 08/180,970, filed Jan. 21, 1994 now abandoned.

### BACKGROUND OF THE INVENTION

#### 1. Field of the Invention

This invention pertains to the telecommunications industry. More particularly, this invention pertains to a high-density fiber distribution frame for use in the telecommunications industry.

#### 2. Description of the Prior Art

In the telecommunications industry, use of fiber optic cables for carrying transmission signals is rapidly growing. To interconnect fiber optic equipment, fiber distribution frames have been developed. An example of a prior art fiber distribution frame is shown in commonly assigned U.S. Pat. No. 4,995,688.

To fiber distribution frame of U.S. Pat. No. 4,995,688 includes a so-called connector module (item 16 in the '688 patent) having a front panel which carries a plurality of adapters (102). Each of the adapters (102) permits attachment of a fiber optic connector (100) to both sides of the adapter in order to optically connect two fiber optic cables.

Typically, the back side of the adapters (102) are provided with connectors secured to fiber optic cables. The cables are connected to various pieces of fiber optic equipment (such as, a fiber-to-copper convertor for converting DS-3 signals to optical signals).

The connections on the back side of the adapters are semi-permanent. Namely, while the connectors on the back side of the adapters can be easily removed, they are normally installed with the intent to maintain the connection of the connector to the rear side of the adaptor without frequent future changes to the connection. On the front side of the adaptor, the fiber optic connector is secured to a fiber cable (for example, a jumper cable) for cross-connecting to other pieces of optical equipment or to any other destination.

With the increase in use of fiber optic cables in the telecommunications industry, it is desirable to provide fiber distribution frames with increased density. By density, it is meant the number of locations per unit volume or unit area for providing connection on the fiber distribution frame.

In products made according to the aforementioned U.S. Pat. No. 4,995,688, a typical fiber distribution frame will have about 576 fiber optic connector locations. In the industry, it is becoming desirable to substantially increase the density to be in excess of 1,400 connectors per frame.

Examples of high-density fiber distribution frames include a frame marketed under the trademark of Fiber Manager by Northern Telecom and described in Northern Telecom Bulletin No. 91-004, Issue No. 2, May, 1991. Another example includes the High Density Interconnect System (HDIC) of AT&T as disclosed in its Product Bulletin 2987D-DLH-7/89, Issue 2.

One problem associated with prior art high-density fiber distribution frames is that the prior art products require substantial displacement of fibers when access to the fiber connectors is required. For example, the Northern Telecom product houses the fibers and connectors in a molded plastic

cassette. The cassette is shown on page 7 of the aforementioned Northern Telecom publication. The particular cassette shown has twelve connectors (paired into six connections). To access any one of the twelve connectors, the cassette must be pulled from the frame approximately three to four inches at which point the cassette drops to an access position as shown on page 6 of the aforementioned bulletin. As a result, even though only one connector may require access, a total of twelve connectors are displaced with substantial displacement of the fiber optic cables associated with each of the twelve connectors.

Unnecessary or excessive displacement of fiber optic cables is undesirable. As fiber optic cables are displaced, they are subject to bending and other forces. As a fiber bends, the fiber can break resulting in loss of transmission through the fiber. Since fibers carry extremely high signal rates, the breakage of a single fiber can result in a substantial loss of data or voice communications. Telecommunications industry standards generally recognize a minimum bending radius of about one and a half inches for optical fibers.

It is an object of the present invention to provide a fiber distribution frame which permits high density, ready access to fiber optic connectors and minimal displacement of fibers when access is being made to connectors.

### SUMMARY OF THE INVENTION

According to a preferred embodiment of the present invention, a cable management system is provided which includes a fixture having a plurality of modules mounted on the fixture. Each of the modules is moveable on the fixture for movement along a line of travel. A releasable lock mechanism is provided for releasably locking each of the modules in a plurality of fixed positions along the line of travel. A plurality of mating elements is secured to each of the modules for movement therewith. The mating elements each includes means for connecting a first signal transmission cable at a rear side of the element with a second signal transmission cable at a front side of the element.

### BRIEF DESCRIPTION OF THE DRAWINGS

FIG. 1 is a front, top and right side perspective view of a frame according to the present invention;

FIG. 2 is a top, front and right side perspective view of two mounting fixtures according to the present invention enjoined by common mounting bracket;

FIG. 3 is a top plan view of the mounting fixtures of FIG. 2;

FIG. 4 is a view similar to FIG. 2 showing a right mounting fixture pivoted to a down position;

FIG. 5 is a top, front and right side perspective view of a left mounting fixture removed from a mounting bracket;

FIG. 6 is a right side elevation view of the mounting fixture of FIG. 5;

FIG. 7 is a front, top and right side perspective view of a cross-connect tray including adapters;

FIG. 8 is a front, top and right side perspective view of a metallic support platform;

FIG. 9 is a front, top and right side perspective view of a left retaining wall;

FIG. 10 is a right side elevation view of the wall of FIG. 9;

FIG. 11 is an enlarged top plan view of a forward end of the wall of FIG. 9;

FIG. 12 is a front, top and right side perspective view of an intermediate retaining wall;

FIG. 13 is a right side elevation view of the wall of FIG. 12;

FIG. 14 is an enlarged top plan view of a forward end of the wall of FIG. 12;

FIG. 15 is a rear, top and left side perspective view of a right retaining wall;

FIG. 16 is left side elevation view of the wall of FIG. 15;

FIG. 17 is a top plan view of a forward end of the wall of FIG. 15;

FIG. 18 is a view similar to FIG. 7 showing connector modules shifted;

FIG. 19 is a front, top and right side perspective view of four mounting fixtures mounted in a frame with an upper right side fixture provided to a down position;

FIG. 20 is a side right elevation view of the view of FIG. 19;

FIG. 21 is a front, top and right side per view of a connector module according to the present invention;

FIG. 22 is a front elevation view of the connector module of FIG. 21;

FIG. 23 is a view taken along lines 23—23 of FIG. 22;

FIG. 24 is a view taken along lines 24—24 of FIG. 22;

FIG. 25 is a front, top and right side perspective view of a fixture according to the present invention and connected to fiber optic cables and;

FIG. 26 is a top plan view of the fixture of FIG. 25.

#### DESCRIPTION OF THE PREFERRED EMBODIMENT

With reference now to the several drawing figures in which identical elements are numbered identically throughout, a description of the preferred embodiment of the invention will now be provided.

With initial reference to FIG. 1, a fiber distribution frame 10 is shown. The frame 10 includes spaced-apart side walls 12,14 connected at their upper ends by a top wall 16. Connected to the forward side of the top wall 16 is a trough 18 for carrying cables and the like as is conventional. The bottom of the frame 10 is provided with a pedestal 20 which also has secured to it a trough 22 for carrying cables and the like. The forward edges of the side walls 12,14 are provided with a plurality of clips 24 for holding fiber optic cables extending vertically in front of side walls 12,14.

Contained within frame 10 between side walls 12,14 are a plurality of left and right mounting fixtures 26,26' (schematically shown in FIG. 1). A detailed description of mounting fixtures 26,26' is provided elsewhere in this specification. The fixtures 26,26' are mounted to be aligned in two columns of ten fixtures per column with the two columns in horizontal alignment. It will be appreciated that the specific number of fixtures 26,26' and their alignment is shown for the purposes of illustrating a preferred embodiment and a different number and alignment of fixtures can be provided within a frame 10.

The fixtures 26,26' are illustrated in FIG. 2 with the fixtures 26,26' paired in a common mounting bracket 28. The mounting bracket 28 includes first and second mounting plates 30,32 for attachment to walls 12,14 respectively. First fixed plates 34,36 are secured to each of mounting plates 30,32, respectively, with the fixed plates 34,36 disposed in parallel, spaced-apart alignment and connected by a pivot rod 38. Second fixed plates 40,42 (best shown in FIG. 4) are also fixedly secured to the pivot rod 38 with plates 40,42 disposed intermediate between plates 34,36 and parallel thereto. Plate 40 opposes plate 34 and plate 42 opposes plate 36.

A left fixture 26 is separately shown in FIG. 5. Except as will be specifically discussed, fixtures 26,26' are identical and a description of one will suffice as a description of the other. Elements of fixture 26' corresponding to elements of fixture 26 are identically numbered with the addition of an apostrophe to distinguish the fixtures.

The fixture 26 includes a metallic support platform 44 and a plastic molded cross-connect tray 46. The support platform 44 is separately shown in FIG. 8 and includes parallel side walls 45,49 spaced apart by a floor portion 47. A leading edge of the floor portion 47 is provided with parallel cut-outs 51 to define a plurality of support fingers 53.

The cross-connect tray 46 is separately shown in FIGS. 7 and 18. The cross-connect tray 46 includes a flat base 48 (which is secured to floor 47 of platform 44). Intricately molded with base 48 at a rear edge thereof are clips 50 sized to snap fit onto pivot rod 38 permitting clips 50 (and hence cross-connect tray 46) to rotate or pivot about the axis (X—X in FIG. 2) of the pivot rod 38. Pivot rod 38 and axis X—X are horizontal when the mounting fixture 26 is secured within the frame 10.

The upper surface of the base 48 is provided with a plurality of triangular-shaped walls including a left wall 52a, a right wall 52b and a plurality of intermediate walls 52c. The walls 52a—52c are numbered and shown assembled in FIG. 26 and are shown separately in FIGS. 9—17.

A wall is mounted on each support finger 53. The plurality of walls 52a—52c are vertical when base 48 is horizontal and each extends generally perpendicular to the pivot axis X—X of clips 50 with the walls 52a—52c disposed in spaced-apart, parallel alignment. Accordingly, opposing surfaces of each of the walls 52a—52c define a plurality of discrete channels 54. (FIG. 18). Also, opposing surfaces of each of the walls 52a—52c have formed therein parallel spaced-apart grooves 56 which extend perpendicular to the base 48.

Disposed within each of the channels 54 is a module 58. As best shown in FIGS. 21—24, each of modules 58 is a generally box-like construction including side walls 60,62. Each of side walls 60,62 is provided with a projecting rail 64 sized to be sideably received within grooves 56. Accordingly, rails 62,64 are received within grooves 56 relative to the platform 48 only in a direction of travel A (FIG. 18) which is perpendicular to the pivot axis X—X of the clips 50. The direction of travel A is vertical when base 48 is horizontal.

The rails 64 have beveled edges which taper inwardly toward the side walls 60,62. The groove 56 are complementary shaped. Accordingly, when rails 64 are received within the grooves 56, the rails can only move in the direction of the grooves 56. This structure provides lateral support to the walls 52a—52c.

The modules 58 further include top and bottom walls 66,68 which are provided with a releasable lock mechanism 70 for independently locking each of the modules 58 in any one of a plurality of fixed positions along the line of travel A. The lock mechanisms 70 include tabs 74 secured to the walls 66,68 by hinge members 76. It will be appreciated that each of modules 58 is formed from an injection-molded plastic. The hinge member 76 is provided with a narrowed mid-point 78 (FIG. 23) to permit the material of the hinge member 76 to rotate about the mid-point 78 when an operator grasps the tab 74 and urges it toward the walls 66,68. The tabs 74 are also provided with a rear edge 80 (FIG. 23) which projects rearwardly from the hinge members 76. Further, a stop 75 is provided on each of walls 66,68 to limit the stroke of tabs 74 to prevent breakage of narrowed mid-point 78.

The lock mechanism **70** are sized such that the rear edges **80** oppose and abut the top and bottom edges **82** of the wall members **52a-52c** when the modules **58** are in a first or neutral position as shown in FIG. 7. In this position, the lock members **74** are shown biased to a lock position with the rear edges **80** opposing and abutting the top and bottom edges **82** to prevent movement of the modules **58** along the line of travel **A**.

By pressing on the tabs **74** and urging them toward the top and bottom walls **56,58**. The lock mechanism **70** are moved from their locked position to an unlocked position with the rear edges **80** clear of the top and bottom edges **82**. So cleared, the modules **58** may be individually moved either up or down (i.e., in the direction of the line of travel **A** as shown in FIG. 18). Centrally positioned between the top and bottom edges **82** on each of walls **52a-52c** are grooves **84,85**. When either of the lock mechanisms **70** is in the region of the groove **84,85**, an operator may release the lock mechanism **70** such that its natural bias causes the edge **80** to be received within the grooves **84,85**. Accordingly, each of the modules **58** may be locked in an up position (with edge **80** of the lower lock mechanism **70** received within lower groove **85**) or in a down position (with edge **80** of the upper lock mechanism **70** received within upper groove **84**).

Each of modules **58** has a hollow construction which in a preferred embodiment is sized to receive six fiber optic connector adapters disposed in an abutting linear array. In the preferred embodiment shown, the specific adapters **90** are well-known and so-called SC adapters for receiving and retaining SC connectors at opposite ends of each of the adapters **90** such that each adaptor **90** joins and optically couples two fiber optic connectors.

It will be appreciated that SC adaptors form no part of this invention per se. Such adapters are commercially available, well-known items. An example of such an adaptor is shown in commonly-assigned and co-pending U.S. Pat. application Ser. No. 08/065,139, filed May 30, 1993. Also, it will be appreciated that while SC adapters **90** are shown in use in a preferred embodiment, different types of adapters for different types of fiber optic connectors (for example, FC, D4 or other connectors) could also be utilized in the modules **58** with internal geometry of the modules **58** simply modified to accommodate different external geometry of different connector adapters.

With reference now back to FIGS. 4 and 5, each of the cross-connect trays **46** is secured (through bolts or the like) to the support platforms **44**. Sidewalls **45, 49** of left fixture **26** are sized to closely face walls **42,36**. Side walls **45' 49'** of right fixture **26'** are sized to closely face walls **34,40**. The side walls **45,49** carry spring-loaded locking tabs **103** which can be pulled inwardly to retract a lock pin **102** (FIG. 5). Upon release of the tabs **103**, the tabs **103** are spring-biased to permit locking pins **102** to protrude beyond the exterior of the side walls **45,49**. Opposing surfaces of the plates **34,40, 42** and **36** are provided with detents **101** (FIG. 4) sized to receive the pins **102** such that the support platform **44** and attached cross-connect trays **46** may be rotated about pivot rod **38** to any one of a plurality of rotated positions and fixed in place in the fixed position. FIG. 4 shows a mounting fixture **26** in a horizontal position and a second mounting fixture **26'** rotated about pivot rod **38** to a down position.

The forward edge of each of the support platforms **44** is provided with extension side walls **100,102** which extend from the side plates **45,49**. The extension walls **100,102** extend forwardly beyond the front side of the adapters **90** by a distant sufficient to permit connectors to be inserted within the adapters **90** as will become apparent.

The extension walls **100,102** are joined by a forward wall **104**. Extending upwardly from forward wall **104** is a designation plate **106** which provides a flat surface generally parallel to the plane of the front ends of the adapters **90**. The flat surface of the designation plate **106** provides a surface on which a designation strip can be attached to permit an operator to place identifying information or the like. The plate **106** also protects the adaptors **90** and attached connectors and fibers from physical damage.

Secured to the forward wall **104** and spaced between the designation plate **106** and the adapters **90** are a plurality of arcuate fanning clips **108**. For the left side fixtures **26**, the fanning chips **108** are arced to direct fibers from the adapters to the left side of the frame. For the right side fixture **26'**, the fanning clips **108** are oriented to direct fibers from the adapters **90** to the right side of the frame. Further, each of the fixtures **26** is provided with a radius plate **110** with an attached fanning clip **112**. The plate **110** permits fibers to be draped downwardly through clip **112** with the radius **110** limiting the bending of the fibers to prevent excess bending.

Connected to the fixture **26** on the rear side thereof may be provided any one of a plurality of different styles of cable management fixtures **120**. The cable management fixtures **120** shown in FIG. 4 includes a plurality of fanning clips for cable management as well as takeup spools for taking up excess amounts of cable. It will also be appreciated that the rear area of the fixtures **26** can be provided with a variety of different cable management devices including splice trays or the like.

With reference now to FIGS. 25-26, the reader will note use of the fixture **26** in use for organizing and cross connecting a plurality of optical fibers. Equipment fibers **130** enter the rear of the fixture **26** with excess fiber lengths wrapped around the cable management device **120**. The equipment fibers **130** may originate from any one of a plurality of different types of fiber optic equipment such as fiber-to-copper convertors. Each of the fibers **130** is terminated at an SC connector **132**. The connector **132** is received within the back end of adapters **90**. Cross-connect fiber cables (frequently referred to as jumpers) **140** are passed through clip **112** and individually fanned by fanning clips **108** toward adapters **90**. Each of the fibers **140** terminates at an SC connector **142** which is each received within the forward end of an adaptor **90** such that each one of connectors **132** is individually connected to a singular one of a plurality of connectors **142**.

From time to time, it is desirable to replace or move the cross-connect cables **140**. If the cables or connectors of the top three adaptors of a given module **58** are desired to be accessed, the operator grasps the locking tabs **74** and moves the module upwardly to the position of the raised module **58** shown in FIG. 25. In this position, each of the top three of the connectors **142** of the module is readily accessible without interference from the designation strip **106**. If the bottom three of the connectors **142** of the same module **58** are to be accessed, the operator simply engages the tabs **74** and moves the connector downwardly until the top tab **74** is received within the groove **84** to lock the module **58** in the down position. In the down position, the bottom three of the connectors **142** is accessible beneath the designation strip **106** without interference from the designation strip **106**. When no connectors are to be accessed, the module **58** is placed in its neutral position with all of the connectors **142** protected from impact or other interference by means of the designation strip **106** and the forward wall **104**.

The reader will note that in order to obtain access to any one of the connectors **142** in a module **58**, the module **58** is

only moved a very small distance. Also, only six adaptors **90** are moved at a time. The very small movement associated with accessing each of the connectors results in a minimal probability of damage of any one of the fiber optic cables.

The benefits of the present invention include limited displacement of the fibers. In the prior art, when a tray containing several connectors is moved, the fibers are displaced axially by a substantial amount (e.g., about 3 inches). In the present invention, as a module **58** is moved up or down (about 1.5 inches) the fiber experiences very little axial movement with most of the movement accommodated by a lifting or lowering movement of the fiber transverse to the fiber's axis.

While the back connectors **132** are semi-permanently installed, it is desirable, from time to time, to be able to have access to the connectors **132** (particularly when the connectors **132** are initially installed). However, if access to back connectors **132** is desired, they may be accessed the same as the front connectors **142** (i.e., by raising or lowering modules **58**).

In certain installations, only the front of frame **10** is accessible to an operator. In such installments, access to the cable management device **120** is obtained through the tilt feature of the fixture **26**. Namely, to obtain access to the cable management device **120** from the front of frame **10**, the tabs **103** are pulled inwardly to retract lock pins **102**. With the pins **102** retracted, the entire fixture **26** rotates about the pivot rod **38** to a down position as shown by fixture **26'** in FIG. **4**. In the down position, the cable management device **120** is readily accessible to an operator facing the front of the frame **10**.

Other modifications of the invention may be apparent to one skilled in the art. For example, in the preferred embodiment illustrated, a module **58** with all six adaptors **90** is moved up or down from the neutral position. Alternatively, the module **58**, could be split in half with the top half moved up to access the top three connectors and with the bottom half independently moved down to access the bottom three adaptors.

Also, as an alternative, the modules **58** can be provided with additional functions. In the preferred embodiment illustrated, the modules **58** retain only adaptors **90**. However, modules **58** can include products other than adaptors **90**. For example, modules **58** may house optical splitters, WDM's (wave division multiplexers) or other equipment. While adaptors **90** may be used with such enhancements, adaptors **90** may not be necessary (e.g., such enhanced modules may be provided with fiber pigtailed).

From the foregoing detailed description of the present invention, it has been shown how the objects of the invention have been attained in a preferred manner. However, modifications and equivalents of the disclosed concepts, such as those which readily occur to one skilled in the art, are intended to be included within the scope of the claims which are appended hereto.

What is claimed is:

**1.** A signal transmission cable management system comprising:

a fixture;

a plurality of modules mounted on said fixture with each of said modules movably mounted on said fixture for movement along a line of travel, each one of said modules including a plurality of adaptor means for holding a fiber optic connector, each one of said adaptor means movable with said one of said modules along said line of travel;

releasable lock means for releasably locking each of said modules in any one of a plurality of fixed positions along said line of travel;

means for connecting a first signal transmission cable at a rear side of said module with a second signal transmission cable connected at a front side of said module.

**2.** A system according to claim **1** wherein said modules each have a longitudinal axis; said modules mounted on said fixture in side-by-side relation with said longitudinal axes generally parallel to said line of travel, said plurality of adaptor means linearly disposed along said longitudinal axis.

**3.** A system according to claim **1** wherein said fixture includes a plurality of spaced-apart walls, opposing pairs of said walls, defining a plurality of channels, each of said modules being disposed within a respective channel, cooperating guide means for each of said modules and said walls for attaching said modules to said walls and accommodating movement of each of said modules along said line of travel.

**4.** A system according to claim **1** wherein each of said plurality of fixed positions includes a first, second and third position, each linearly separated along said line of travel.

**5.** A system according to claim **1** comprising a frame having mounting means for mounting said fixture in said frame:

said mounting means including a pivot attachment for said fixture to pivot relative to said frame about said pivot axis.

**6.** A system according to claim **5** wherein said pivot axis is generally perpendicular to said line of travel.

**7.** A system according to claim **5** wherein said mounting means further includes a frame lock for releasably locking said fixture in any one of a plurality of a pivoted positions about said pivot axis.

**8.** A system according to claim **1** comprising a plurality of mating elements secured to each of said modules, said mating elements each including means for connection of said front side, respectively, with said first and second cables optically coupled.

**9.** A system according to claim **8** wherein said mating elements are mounted in a linear array defining a longitudinal axis for each of said modules, said modules mounted on said fixture in side-by-side relation with said longitudinal axes generally parallel to said line of travel.

**10.** A signal transmission cable management system comprising:

a fixture;

a plurality of modules mounted on said fixture with each of said modules movably mounted on said fixture for movement along a line of travel;

releasable lock means for releasably locking each of said modules in any one of a plurality of fixed positions along said line of travel, each of said plurality of fixed positions including a first, second and third position, each linearly separated along said line of travel;

means for connecting a first signal transmission cable at a rear side of said module with a second signal transmission cable connected at a front side of said module;

a forward wall disposed, spaced from and opposing said front sides of said modules said modules shielded by said forward wall when said one of said modules is in said first position and with a first upper portion of said one of said modules exposed above an upper edge of said forward wall when said one is in said second position and with a second portion of said one exposed below a lower edge of said forward wall when said one is in said third position.

11. A signal transmission cable management system comprising:

- a fixture;
- a plurality of modules mounted on said fixture with each of said modules movably mounted on said fixture for movement along a line of travel;
- releasable lock means for releasably locking each of said modules in any one of a plurality of fixed positions along said line of travel;
- means for connecting a first signal transmission cable at a rear side of said module with a second signal transmission cable connected at a front side of said module;
- said fixture including a plurality of spaced-apart walls, opposing pairs of said walls, defining a plurality of channels, each of said modules being disposed within a respective channel, cooperating guide means for each of said modules and said walls for attaching said modules to said walls and accommodating movement of each of said modules along said line of travel;
- said lock means including a locking member on each of said modules, said locking member moveable between a locked position and an unlocked position; said walls and said locking member including cooperating elements for restraining said modules for movement along said line of travel at each of said plurality of fixed positions when said locking member is in said locked position and accommodating movement of said module along said line of travel when said locked member is in said unlocked position.

12. A system according to claim 11 wherein said cooperating elements includes a detent formed in said walls and corresponding with said plurality of fixed positions, said locked member including an edge sized to be received within said detent when said lock member is in said locked position and said edge removed from said detent when said lock member is in said unlocked position.

13. A system according to claim 12 wherein said lock member is biased toward said locked position.

14. A signal transmission cable management system comprising:

- a fixture;
- a plurality of modules mounted on said fixture with each of said modules movably mounted on said fixture for movement along a line of travel;
- releasable lock means for releasably locking each of said modules in any one of a plurality of fixed positions along said line of travel;
- means for connecting a first signal transmission cable at a rear side of said module with a second signal transmission cable connected at a front side of said module;
- said fixture including a plurality of spaced-apart walls, opposing pairs of said walls, defining a plurality of channels, each of said modules being disposed within a respective channel, cooperating guide means for each of said modules and said walls for attaching said modules to said walls and accommodating movement of each of said modules along said line of travel;
- said cooperating guide means including a rail on each of said modules and a mating groove on at least one of said walls opposing each of said channels with said rails slidable received within said groove and with said rails sliding within said groove along said line of travel.

15. In a signal transmission cable management system having a fixture including a plurality of spaced apart walls defining a plurality of parallel spaced apart cavities, said

walls including first and second parallel and opposing recesses; an optic module for mounting in said cavities, said module comprising:

- a body sized to be slidably received within said cavity for movement along a line of travel, said body having first and second parallel rails, said rails sized to be slidably received within said recesses;
- said body including a plurality of adaptor means for connecting a plurality of fiber optic cables to said body, said plurality of adaptor means linearly aligned along said line of travel;
- said body including latch means for securing said body to said fixture in any one of a plurality of fixed positions along said line of travel.

16. A signal transmission cable management system comprising:

- a fixture; and
- a plurality of modules mounted on said fixture with each of said modules movably mounted on said fixture for movement along a line of travel, each one of said modules including a plurality of adaptor means for holding a fiber optic connector, each adaptor means having opposite ends for coupling to a fiber optic cable connector, each one of said adaptor means movable with said one of said modules along said line of travel, said plurality of adaptor means linearly disposed along said line of travel for each of said modules.

17. A system according to claim 16 wherein each of said plurality of adaptor means couples first and second SC fiber optic cable connectors.

18. A system according to claim 16 wherein said modules each have a longitudinal axis, said modules mounted on said fixture in side-by-side relation with said longitudinal axes generally parallel to said line of travel, said plurality of adaptor means linearly disposed along said longitudinal axis.

19. A system according to claim 16 wherein said fixture defines a plurality of channels, each of said modules being disposed within a respective channel, and further comprising cooperating guides on each of said modules and within said channels accommodating movement of each of said modules along said line of travel.

20. A system according to claim 19 further including a plurality of spaced-apart walls, opposing pairs of said walls defining said plurality of channels, each of said modules being disposed within a respective channel, and wherein said cooperating guides are on each of said walls for attaching said modules to said walls.

21. A signal transmission cable management system comprising:

- a fixture;
- a plurality of modules mounted on said fixture with each of said modules movably mounted on said fixture for movement along a line of travel, each one of said modules including a plurality of adaptor means for holding a fiber optic connector, each adaptor means mountable to a fiber optic cable connector, each one of said adaptor means movable with said one of said modules along said line of travel; and
- a releasable lock for locking each module to said fixture in a first position, each of said locks being releasable to allow movement of each of said modules to a second position along said line of travel.

22. A system according to claim 21 wherein each of said plurality of adaptor means is mountable to an SC fiber optic cable connector.



23. A signal transmission cable management system comprising:

a fixture; and

a plurality of modules movably mounted on said fixture with each of said modules individually movable relative to said fixture, each one of said modules including a plurality of adaptor means for holding a fiber optic connector, each adaptor means mountable to a fiber optic cable connector, each one of said adaptor means movable with said one of said modules, wherein said modules each have a longitudinal axis, said modules mounted on said fixture in side-by-side relation with said longitudinal axes generally parallel to one another, said plurality of adaptor means linearly disposed along said longitudinal axis, each of said modules movable in a direction parallel to the longitudinal axis of each module.

24. A system according to claim 23 wherein each of said plurality of adaptor means is mountable to an SC fiber optic cable connector.

25. A signal transmission cable management system comprising:

a fixture; and

a plurality of modules mounted on said fixture with each of said modules movably mounted on said fixture for movement along a line of travel, each one of said modules including a plurality of adaptor means for holding a fiber optic connector, each adaptor means mountable to a fiber optic cable connector, each one of said adaptor means movable with said one of said modules along said line of travel, wherein said fixture includes a plurality of a spaced-apart walls, opposing pairs of said walls defining a plurality of channels, each of said modules being disposed within a respective channel, and further comprising cooperating guides on each of said modules and said walls for attaching said modules to said walls and accommodating movement of each of said modules along said line of travel.

26. A system according to claim 25 wherein each of said plurality of adaptor means is mountable to an SC fiber optic cable connector.

27. A signal transmission cable management system comprising:

a fixture;

a plurality of modules mounted on said fixture with each of said modules movably mounted on said fixture for movement along a line of travel, each one of said modules including a plurality of adaptor means for holding a fiber optic connector, each adaptor means for connecting first and second fiber optic cable connectors, each one of said adaptor means movable with said one of said modules along said line of travel, said plurality of adaptor means linearly disposed along said line of travel for each of said modules; and a hinged locking tab at an end of each module for selectively locking each module to said fixture.

28. In a signal transmission cable management system having a fixture including a plurality of spaced apart walls defining a plurality of parallel spaced apart cavities, said walls including first and second parallel and opposing recesses; a module for mounting in said cavities, said module comprising:

a body sized to be slidably received within said cavity for movement along a line of travel, said body having first and second parallel rails, said rails sized to be slidably received within said recesses; and

said body including a plurality of adaptor means for connecting a plurality of fiber optic cables to said body, said plurality of adaptor means linearly aligned along said line of travel.

29. A module according to claim 28 wherein each of said plurality of adaptor means couples first and second SC fiber optic cable connectors.

30. A module according to claim 28 comprising a latch for securing said body to said fixture in a first position.

\* \* \* \* \*

UNITED STATES PATENT AND TRADEMARK OFFICE  
**CERTIFICATE OF CORRECTION**

PATENT NO. : RE 38,311 E  
APPLICATION NO. : 09/035377  
DATED : November 11, 2003  
INVENTOR(S) : Wheeler

Page 1 of 1

It is certified that error appears in the above-identified patent and that said Letters Patent is hereby corrected as shown below:

Col. 11, line 32, claim 25: "plurality of a spaced-apart walls," should read  
--plurality of spaced-apart walls,--

Signed and Sealed this

Seventeenth Day of July, 2007

A handwritten signature in black ink on a light gray dotted background. The signature reads "Jon W. Dudas" in a cursive style.

JON W. DUDAS

*Director of the United States Patent and Trademark Office*

UNITED STATES PATENT AND TRADEMARK OFFICE  
**CERTIFICATE OF CORRECTION**

PATENT NO. : RE38,311 E  
APPLICATION NO. : 09/035377  
DATED : November 11, 2003  
INVENTOR(S) : Wheeler

Page 1 of 1

It is certified that error appears in the above-identified patent and that said Letters Patent is hereby corrected as shown below:

Col. 1, line 3: insert the following paragraph:

--Notice: More than one reissue application has been filed for the reissue of U.S. Patent No. 5,497,444. The reissue patent applications include the present reissue application Serial No. 09/035,377, filed March 5, 1998, now U.S. Patent RE 38,311; and reissue application Serial No. 10/391,052, filed March 18, 2003. Reissue application Serial No. 10/391,052 is a continuation reissue application of application Serial No. 09/035,377.--

Signed and Sealed this  
Eighth Day of March, 2011

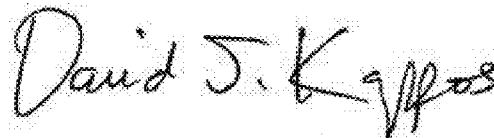

David J. Kappos  
*Director of the United States Patent and Trademark Office*

UNITED STATES PATENT AND TRADEMARK OFFICE  
**CERTIFICATE OF CORRECTION**

PATENT NO. : RE38,311 E  
APPLICATION NO. : 09/035377  
DATED : November 11, 2003  
INVENTOR(S) : Todd A. Wheeler

Page 1 of 1

It is certified that error appears in the above-identified patent and that said Letters Patent is hereby corrected as shown below:

Column 1, lines 11-18, below the heading, "CROSS-REFERENCE TO RELATED APPLICATIONS", should read: --Notice: More than one reissue application has been filed for the reissue of patent 5,497,444. The reissue applications are application nos. 12/930,087, which is a continuation of 12/804,078, which is a continuation of 10/391,052, now Patent No. RE41,460, which is a continuation of 09/035,377, now Patent No. RE38,311, all of which are reissue applications of Patent No. 5,497,444.--

Signed and Sealed this  
Ninth Day of October, 2012

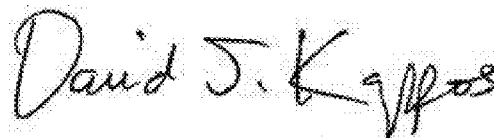
A handwritten signature in black ink that reads "David J. Kappos". The signature is written in a cursive style with a large initial "D".

David J. Kappos  
*Director of the United States Patent and Trademark Office*