

(12) **UK Patent Application** (19) **GB** (11) **2501629** (13) **A**

(43) Date of Reproduction by UK Office **30.10.2013**

(21) Application No: **1311588.6**
(22) Date of Filing: **05.01.2012**
Date Lodged: **27.06.2013**
(30) Priority Data:
(31) **61436772** (32) **27.01.2011** (33) **US**
(86) International Application Data:
PCT/US2012/020251 En 05.01.2012
(87) International Publication Data:
WO2012/102841 En 02.08.2012

(51) INT CL:
H04Q 1/06 (2006.01)
(56) Documents Cited:
US 5934656 A **US 20050016617 A1**
(58) Field of Search:
INT CL **A44B, B65D, G01B, H02G, H04Q**
Other: **EPO-Internal**

(71) Applicant(s):
CommScope Inc. of North Carolina
1100 CommScope Place SE, Hickory 28602,
North Carolina, United States of America
(72) Inventor(s):
Scott Martin Keith
(74) Agent and/or Address for Service:
Yeadon IP Limited
Leeds Innovation Centre, 103 Clarendon Road,
LEEDS, LS2 9DF, United Kingdom

(54) Title of the Invention: **Datacommunications/telecommunications patching systems with bundled patch cord assembly**
Abstract Title: **Datacommunications/telecommunications patching systems with bundled patch cord assembly**

(57) A cord bundle assembly includes: a plurality of communications cords, each of the communications cords comprising a plurality of communications signal-carrying members, the communications cords being grouped as a bundle; and a cord management assembly. The cord management assembly includes: a fixed cuff that encircles and is fixed relative to the plurality of communications cords; a slip cuff that encircles and is slidable relative to the plurality of communications cords; and a generally cylindrical sleeve having first and second ends, the fixed cuff being mounted to the first end, and the slip cuff being mounted to the second end. This configuration can assist in the management and organization of cords arranged in a cord bundle as they are routed between communications equipment.

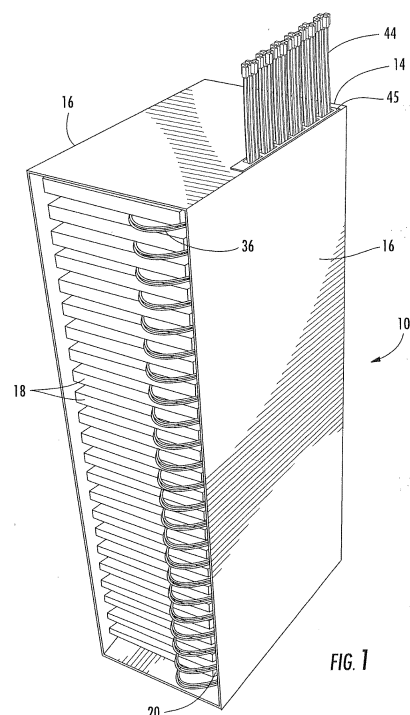

GB 2501629 A