

Dec. 9, 1969

R. E. ERICSON ET AL

3,482,576

EASY DEFLATABLE RETENTION CATHETER

Filed May 9, 1966

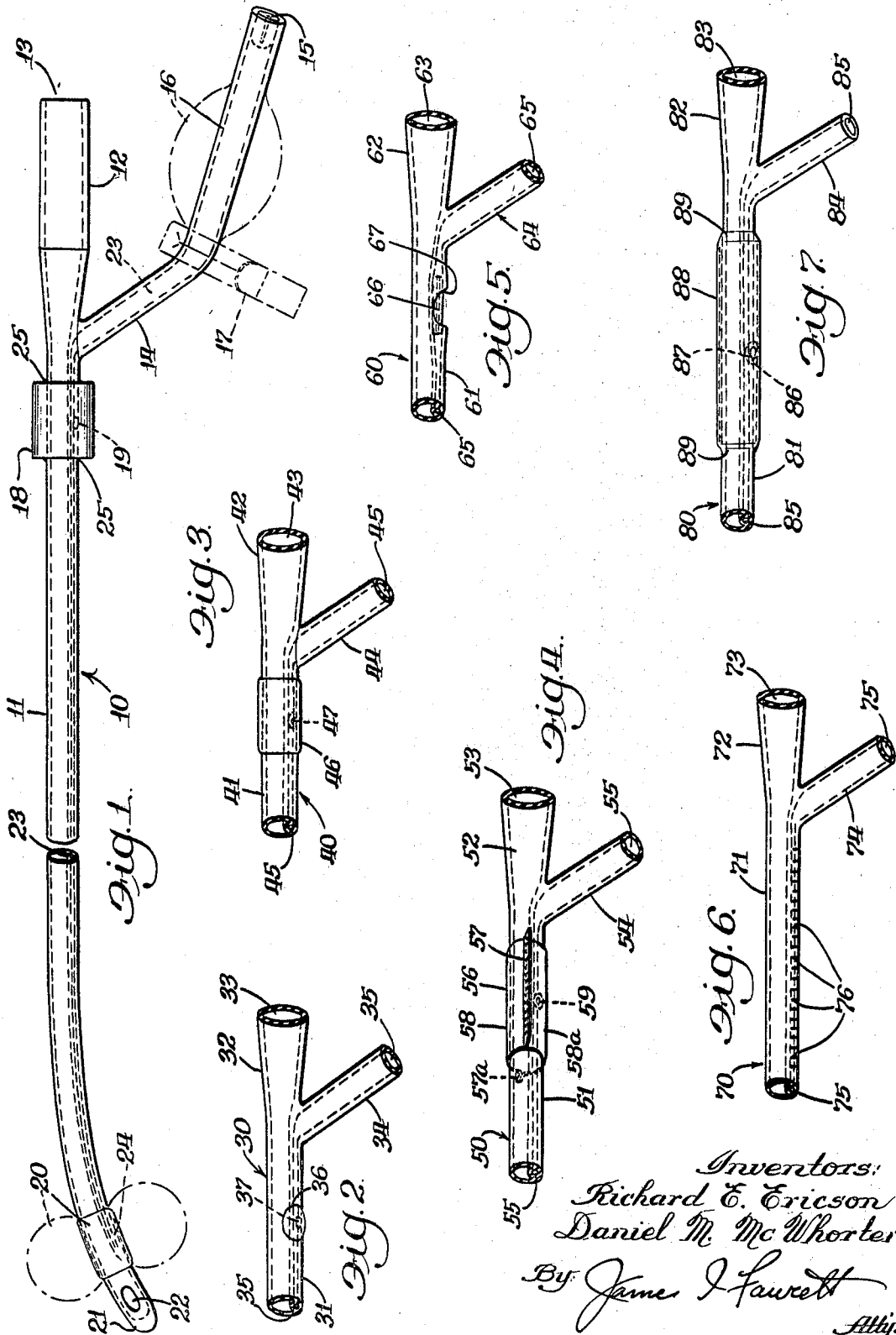

Inventors:
Richard E. Ericson
Daniel M. McWhorter
By James J. Lawrence
Att'y.

3,482,576

EASY DEFLATABLE RETENTION CATHETER

Richard E. Ericson, Barrington, and Daniel M. McWhorter, Palatine, Ill., assigns to The Kendall Company, Boston, Mass., a corporation of Massachusetts

Filed May 9, 1966, Ser. No. 548,455

Int. Cl. A61m 25/00, 31/00

U.S. Cl. 128—349

7 Claims

ABSTRACT OF THE DISCLOSURE

An inflatable retention catheter is described having a sealed vent means associated with the inflation lumen actuatable into an open position when the catheter tubing is stretched along the longitudinal axis thereof thereby providing an escape route for the inflation medium deflating the retention balloon as the catheter is pulled out of the body cavity.

This invention is concerned with drainage tubes for draining body fluids from an animal body. Specifically the invention is concerned with drainage tubes which are retained within the body usually in a cavity thereof by inflated retention means. Such drainage tubes are generally not removed from the body by pulling on the portion exterior of the body without first deflating the retention means. Deflation in the ordinary manner is accomplished by drawing out the fluid by means of a hypodermic syringe and needle or by severing the channel leading to the inflated retention means.

Occasionally, however, the drainage tube is partially or wholly removed with the inflation means still inflated. This may come about accidentally when the patient is moved or circumstances may arise in which the patient pulls or attempts to pull out the drainage tube. When this occurs the body epithelium is frequently traumatized to such an extent that additional medical attention is required.

It is an object of this invention to prevent or reduce the incidence of injury to the body cavity upon forceful withdrawal of a drainage tube.

Another object of the invention is the provision of a convenient deflation means which requires no deflation instrument.

Still another object is the provision of a safety deflation device which provides closed system deflation.

Other objects of the invention will be apparent upon an examination of the specification and the drawings.

Referring now to the drawings:

FIGURE 1 illustrates a drainage tube of the invention having an inflatable retention means with a deflating device therefor.

FIGURES 2 to 6 inclusive illustrate a portion of a drainage tube similar to that illustrated in FIGURE 1 but with various modifications of the deflating device.

FIGURE 7 illustrates a portion of a drainage tube similar to that illustrated in FIGURE 1 with any of the deflation devices of FIGURES 1 to 6 inclusive but including a reservoir enclosing the deflating device.

The preferred embodiment of the invention is a Foley catheter or the self-inflating modification of the Foley catheter fitted with a deflation device but any drainage tube whether of rubber latex or synthetic stretchable polymer which has inflatable retention means and is so fitted is within the invention.

The objects of the invention are preferably attained when one or more closed vents, into the lumen which provides fluid for the drainage tube retention means, are

opened when the drainage tube is stretched thus causing the retention means to lose its fluid.

Referring once more to the drawings:

FIGURE 1 illustrates a typical drainage tube of the invention in the form of a catheter 10 having a main arm 11 and a side branch 14. The main arm has a bell 12 for a connecting tube fitting with a main lumen 13 which extends to the drainage orifice 22 in the tip 21. A smaller inflation lumen 23 is also within the main arm 11. This lumen 23 is continuous into side branch 14 where it widens. It is closed by the combination filling and stop plug 15 and has an opening 24 into the inflatable retention means 20. Another opening, a vent 19, into this lumen 23 is closed when the catheter is unstretched by relatively non-elastic annular band 18 which is sealed to the main arm at both ends by the seals 25. When the catheter main arm is stretched by a force the seals 25 rupture and the retention means 20 loses its fluid through the vent 19, the fluid passing between the annular band and the reduced main arm 11.

Constructively shown is a self-inflating embodiment of the catheter of FIGURE 1. The clamp 17 holds the fluid in the inflated reservoir 16 until the retention means is in place whereupon the clamp is removed and the retention means 20 inflated. In the absence of the self-inflation feature, retention means 20 is inflated by forcing a hypodermic needle through the plug 15 and forcing fluid therethrough into the lumen 23 from a syringe. Obviously the plug 15 may be replaced by a well-known needleless valve and the syringe could be used directly without a needle.

FIGURE 2 illustrates an embodiment of only that portion of the invention which is concerned with the deflation vent. The main arm 31 of the tube 30 contains a main lumen 33 and an inflation lumen 35 which latter opens into side branch 34. A portion of a connecting bell 32 is shown. The lumen 35 contains a vent 37 which is closed by an occluding closure 36 which in FIGURE 2 is shown as a patch. This closure may take the form of a patch which merely covers the vent or may extend at least partially into the vent opening in the form of a plug. This patch or plug may be any unitary material which seals with the vent walls when applied and preferably is shaped to overlap the marginal edges of the vent and adhere thereto. Waxes, gums, adhesive-films, resins and the like make suitable vent closures but metallic or other rigid plugs may be utilized. The closure becomes at least partially detached from the vent opening to permit the escape of the inflation medium when this portion of the tube is stretched.

In FIGURE 3 also only that portion of a drainage tube retained by inflatable means which relates to the deflation vent is illustrated. It comprises a drainage tube 40 with a main arm 41 and a side branch 44. The main arm contains a drainage lumen 43 and an inflation lumen 45 and a portion of a connecting bell 42. The inflation lumen 45 opens into the side branch 44 and contains a deflation vent 47. The vent 47 is sealed by a tubular band 46 which is applied and shrunk into a sealed relationship with the main arm 41. When the main arm is reduced in size by stretching, the seal is broken and the retention means loses its fluid through the deflation vent.

FIGURE 4 again illustrates a modified vent structure. Only that portion of a drainage tube 50 retained by inflatable means which relates to the vent structure is shown. Like FIGURES 2 and 3, FIGURE 4 includes a main arm 51 containing a main lumen 53, an inflation lumen 55 and a portion 52 of a connecting bell. A side branch 54 contains an enlarged continuation of the inflation lumen 55. Inflation lumen 55 has a vent 59 which is sealed by band 56 formed by two flat heat shrinkable

films 58 and 58a sealed together with seals 57 and 57a. After the band 56 is properly positioned, it is shrunk in place by the application of heat to create the seal.

FIGURE 5 illustrates again only that portion of an inflatably retained drainage tube 60 which pertains to the deflation vent. The main arm 61 which has a connecting bell portion 62 contains a drainage lumen 63 and an inflation lumen 65. The latter continues in an enlarged form into the side branch 64. Lumen 65 also contains a vent 67 which is closed by a relatively non-elastic insert tube 66. The latter is retained within the lumen 65 by any of the well-known sealing methods including elastic retention. When the main arm is stretched, one end of the relatively non-elastic insert tube is freed and the vent opening is no longer occluded. The inflation means thus loses its fluid through the deflation vent.

FIGURE 6 once more is that portion of an inflatably retained drainage tube 70 which pertains to the deflation vent. The main arm 71 which has a connecting bell portion 72 contains a main drainage lumen 73 and an inflation lumen 75. The latter continues in an enlarged form in the side branch 74. A plurality of vents 76, which are closed before the main arm is stretched, open when the main arm is in stretched condition thus causing the inflation means to lose its fluid through the open vents.

FIGURE 7 illustrates that portion of an inflatably retained drainage tube 80 which pertains to the deflation vent. The main arm 81 which has a connecting bell portion 82 contains a main drainage lumen 83 and an inflation lumen 85. The latter continues into side branch 84 in enlarged form. Lumen 85 contains a deflating vent 87 which may be closed by closures 86 which may be any of the closures shown in FIGURES 1 to 5 inclusive. A series of vents which are self-closing as in FIGURE 6 may also be utilized. A sealed sleeve 88, sealed at its ends 89 by any well-known sealing method, covers the deflation vent and its closure, if any. The sleeve must either be stretchable or have sufficient slack material so that its seals will remain intact. It should also have sufficient volume to contain the fluid lost from the retention means when the main arm is stretched, opening the vent or vents.

While the preferred materials for closure bands such as the band 18 of FIGURE 1 are thermoplastic and thermosetting polymeric materials and the preferred materials for band 46 of FIGURE 3 are thermoplastic polymers, other impermeable bands both rigid and flexible are suitable. Thus fibrous rigid and flexible tubes and cardboard tubes interiorly coated or otherwise made impermeable are suitable. Rigid metal bands and flexible metallic foils are also suitable. Most materials may be fastened with cements but where this is difficult, the drainage tube itself may be used to provide an elastic seal. When this is done, the drainage tube is stretched, the band is placed in position over the vent and the drainage tube is allowed to relax to form a tight seal with the inner portion of the band. When the drainage tube is again stretched with the retention means inflated, the fluid escapes from the vent thus deflating the retention means.

We claim:

1. In a drainage device for insertion into an animal body cavity to be drained of fluids having a length of flexible tubing, said tubing having a proximal end and a distal end for insertion into the body cavity, a drainage lumen extending the length thereof, a drainage orifice communicating with the drainage lumen, a separate inflation lumen within said tubing extending from the proximal end to a point proximate the distal end, and an inflatable retention balloon proximate the distal end, said balloon communicating with the inflation lumen and adapted to be inflated by an inflation medium, the im-

provement comprising in combination therewith a normally closed venting means communicating with the proximal end of the inflation lumen, said venting means being actuatable to an open position by reducing the cross-sectional dimension of said inflation lumen at that portion of the inflation lumen communicating with the venting means, said lumen reduction being accomplished by deformation of at least said portion of the inflation lumen.

2. In a drainage device for insertion into an animal body cavity to be drained of fluids having a length of flexible tubing, said tubing having a proximal end and a distal end for insertion into the body cavity; a drainage lumen extending the length thereof, a drainage orifice communicating with the drainage lumen, a separate inflation lumen within said tubing extending from the proximal end to a point proximate the distal end, and an inflatable retention balloon proximate the distal end, said balloon communicating with the inflation lumen and adapted to be inflated by an inflation medium, the improvement comprising in combination therewith sealed vent means positioned along the proximal end of said tubing communicating with the inflation lumen, said sealed vent being adapted to open when the tubing is stretched along the longitudinal axis thereof whereby the inflation medium is ejected through said vent causing the inflated retention balloon to deflate rendering the tubing easily removable from said body cavity.

3. A drainage device in accordance with claim 2 wherein the vent is sealed by means of a relatively rigid, non-stretchable band overlying said vent and encircling the tubing, said band having opposed ends sealed to the tubing which seals are ruptured when the catheter tubing is stretched along the longitudinal axis thereof such that the inflation medium will escape through said vent when so stretched thereby deflating the retention balloon.

4. A drainage device in accordance with claim 2 wherein the vent is sealed by means of a patch overlying said vent which patch is adapted to become at least partially detached from the vent upon stretching of the catheter tubing along the longitudinal axis thereof, allowing the inflation medium to escape deflating the retention balloon.

5. A drainage device in accordance with claim 2 wherein the vent is sealed by means of a non-elastic internal tube sealed to the walls of the inflation lumen thereby occluding the vent whereby longitudinal stretching of the tubing will rupture the seal to open the vent and allow the inflation medium to escape deflating the retention balloon.

6. A drainage device in accordance with claim 2 wherein the sealed vent means comprises a series of vents elastically closed when the tubing is at rest but which open when the catheter tubing is stretched along its longitudinal axis and allow the inflation medium to escape deflating the retention balloon.

7. A drainage device in accordance with claim 2 which includes a sealed reservoir enclosing the closed vent.

References Cited

UNITED STATES PATENTS

281,043	7/1883	Finney	-----	128—246
1,922,084	8/1933	Gerow	-----	128—349
2,854,982	10/1958	Pagano	-----	128—348
3,211,151	10/1965	Foderick et al.	-----	128—349
3,275,001	9/1966	Rosecrans	-----	128—349

DALTON L. TRULUCK, Primary Examiner

U.S. Cl. X.R.

137—145, 342