

(No Model.)

E. G. LAFITE.
VENTILATOR OR BLOWER.

No. 462,142.

Patented Oct. 27, 1891.

Fig. 1.

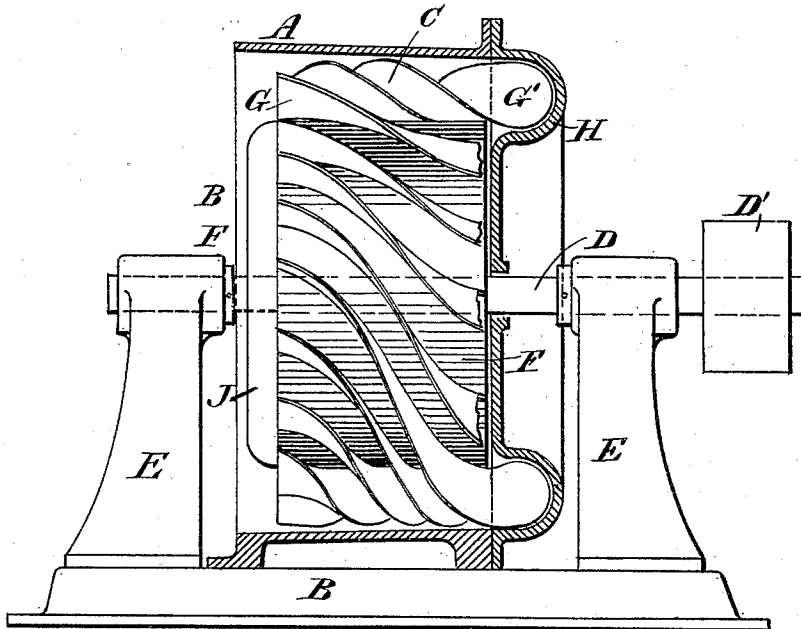
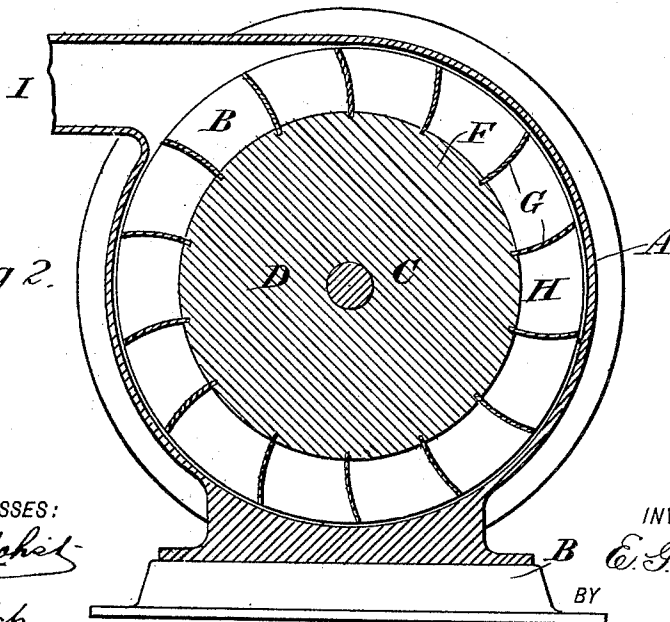

Fig. 2.



WITNESSES:
Paul J. J. J.
C. Sedgwick

INVENTOR:
E. G. Lafite
BY
Murray
ATTORNEYS

UNITED STATES PATENT OFFICE.

EMILE GACHASSIN LAFITE, OF SANTIAGO, CUBA.

VENTILATOR OR BLOWER.

SPECIFICATION forming part of Letters Patent No. 462,142, dated October 27, 1891.

Application filed April 21, 1891. Serial No. 389,788. (No model.)

To all whom it may concern:

Be it known that I, EMILE GACHASSIN LAFITE, of Santiago de Cuba, Cuba, have invented a new and Improved Ventilator or Blower, of which the following is a full, clear, and exact description.

The object of the invention is to provide a new and improved ventilator or blower which is simple and durable in construction, very effective in operation, and adapted for readily exhausting foul air, gases, &c., from rooms, mines, &c., or for forcing or pumping air, gases, liquids, and other fluids to any desired place.

The invention consists of a casing provided with an annular chamber formed with an outlet and a wheel mounted to revolve in the said casing and formed on its periphery with helicoidal blades or wings extending into the said annular chamber.

The invention also consists of certain parts and details and combinations of the same, as will be fully described hereinafter and then pointed out in the claims.

Reference is to be had to the accompanying drawings, forming a part of this specification, in which similar letters of reference indicate corresponding parts in both the figures.

Figure 1 is a transverse section of the improvement, and Fig. 2 is a sectional side elevation of the same.

The improved ventilator or blower is provided with a casing A, secured on a base B and containing a wheel C, fastened on a shaft D, mounted to turn in suitable bearings E, held on the said base B. On the shaft D is secured a pulley D', connected by a belt to suitable machinery for imparting a rotary motion to the said shaft D, so as to revolve the wheel C within the casing A.

The wheel C is provided with a cylindrical drum F, on the periphery of which are secured wings or blades G, arranged helicoidally on the said drum and having their rear ends G' extending beyond the rear face of the drum into an annular chamber H, secured on the rear end of the casing A, so as to close the latter at this end, the front end of the casing being open. From this annular chamber

H leads an outlet-pipe I. On the front of the drum F is secured a cap J, having its end rounded so that the fluid can flow inward easily.

The cross-section of the chamber H is preferably semi-spherical, the ends G' of the blades or wings G being semicircular, so as to fit into the semi-spherical chamber. The helicoidal blades or wings G at the inlet of the casing A extend inward gradually and then their angle with relation to the drum increases very rapidly, so that the blades finally extend parallel to the axis of the drum at the rear face of the same, as is plainly illustrated in Fig. 1, the extension ends G' of the blades being set almost radially to the shaft D. The blades are preferably made of steel, copper, or like material, so as to be sufficiently elastic to vibrate when the machine is at work. When the wheel C is rotated in the casing A, the fluid is drawn into the open end of the latter by the action of the helicoidal wings G, which latter by their helicoidal shape give an increasing velocity to the fluid, the latter being finally discharged into the annular chamber H and forced out of the same through the outlet-pipe I by the action of the extending ends G'.

In case it is desired to use the machine as a pump, the front or open end of the casing A is closed and connected with a suction-pipe, so that the liquid is drawn through the suction-pipe into the casing A by the action of the revolving wheel C and forced out of the casing into the chamber H and out of the latter through the pipe I in the manner above described.

Having thus described my invention, I claim as new and desire to secure by Letters Patent—

1. In a machine of the class described, the combination, with a casing provided at one end with an annular chamber connected with an outlet, of a wheel mounted to revolve in the said casing and formed on its periphery with helicoidal blades or wings extending beyond the one face of the wheel into the said annular chamber, substantially as shown and described.

2. In a machine of the class described, the combination, with a casing open at one end and provided at its other closed end with an annular chamber having an outlet, of a wheel
5 mounted to revolve in the said casing and comprising a drum, and blades or wings set helicoidally on the periphery of said drum and having their rear ends extending beyond the

rear face of the drum into the said annular chamber, substantially as shown and described.

EMILE GACHASSIN LAFITTE.

Witnesses:

W. BRUN,
O. GRUSON.