

OPT DATE 22/05/98 APPLN. ID 46105/97
 AOJP DATE 16/07/98 PCT NUMBER PCT/AU97/00706



AU9746105

(CT)

<p>(51) International Patent Classification ⁶ : A63F 5/00, 5/04, 9/22</p>	<p>A1</p>	<p>(11) International Publication Number: WO 98/18532</p>
		<p>(43) International Publication Date: 7 May 1998 (07.05.98)</p>
<p>(21) International Application Number: PCT/AU97/00706 (22) International Filing Date: 22 October 1997 (22.10.97) (30) Priority Data: PO 3248 25 October 1996 (25.10.96) AU PO 6986 23 May 1997 (23.05.97) AU (71) Applicant (for all designated States except US): COMS21 LIMITED [AU/AU]; 10-12 Cohen Street, Belconnen, ACT 2617 (AU). (72) Inventor; and (75) Inventor/Applicant (for US only): GREEN, Graeme [AU/AU]; 10-12 Cohen Street, Belconnen, ACT 2617 (AU). (74) Agent: PIZZEYS PATENT & TRADEMARK ATTORNEYS; P.O. Box 291, Woden, ACT 2606 (AU).</p>	<p>(81) Designated States: AL, AM, AT, AU, AZ, BA, BB, BG, BR, BY, CA, CH, CN, CU, CZ, DE, DK, EE, ES, FI, GB, GE, GH, HU, ID, IL, IS, JP, KE, KG, KP, KR, KZ, LC, LK, LR, LS, LT, LU, LV, MD, MG, MK, MN, MW, MX, NO, NZ, PL, PT, RO, RU, SD, SE, SG, SI, SK, SL, TJ, TM, TR, TT, UA, UG, US, UZ, VN, YU, ZW, ARIPO patent (GH, KE, LS, MW, SD, SZ, UG, ZW), Eurasian patent (AM, AZ, BY, KG, KZ, MD, RU, TJ, TM), European patent (AT, BE, CH, DE, DK, ES, FI, FR, GB, GR, IE, IT, LU, MC, NL, PT, SE), OAPI patent (BF, BJ, CF, CG, CI, CM, GA, GN, ML, MR, NE, SN, TD, TG).</p> <p>Published With international search report.</p>	

(54) Title: JACKPOT SYSTEM

(57) Abstract

A method of controlling the operation of a plurality of interconnected poker machines (20a, 20b ... 20n) in a controlling system in which a jackpot prize (26) is awarded when a monetary accumulation related to the total monetary value played through the poker machines in a given period of time reaches a jackpot value, the method including providing players of the poker machines with machine readable means of personal identification (21a, 21b ... 21n), recording the identity of players when operating a poker machine and identifying as the jackpot winning player (25) that player identified by the player identification means used to operate the poker machine which when thus operated caused the monetary accumulation to equal or exceed the jackpot value.

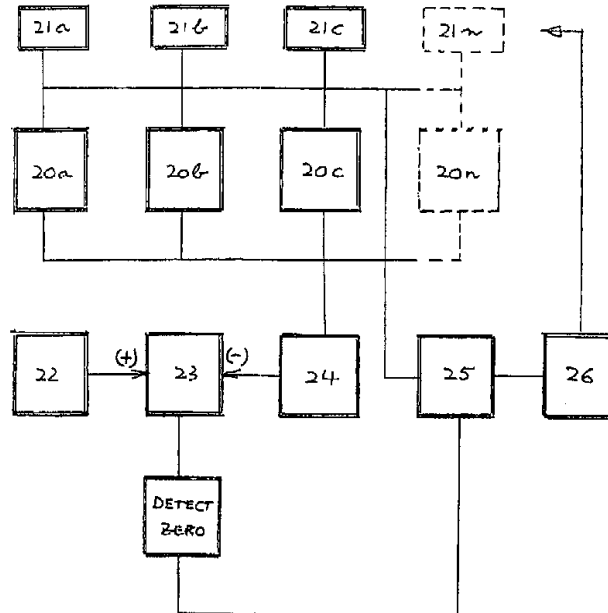

"JACKPOT SYSTEM"**Technical Field**

This invention relates to jackpot systems.

5 The invention has particular but not exclusive application to a jackpot system for, and method of, controlling the operation of a plurality of interconnected poker machines.

10 Background of Invention

So-called linked jackpot systems are known. Australian patent 589158 discloses a linked jackpot system in which a number of poker machines are linked together. As schematically illustrated in FIG 1, in this
15 known system a random number 11 is generated by the computer system to which the poker machines 10a, 10b ...10n are linked. Each of the poker machines produces an incrementing signal when operated by a player. These incrementing signals increment an accumulator 13 which
20 thus records an incrementing total of all playing operations on the system to which the machines are linked and is compared by a comparator 14 with the random number stored in store 12. When the incrementing total equals the random number the machine 10 which when operated
25 caused the incrementing total to equal or exceed the random number is identified by the system and a jackpot 15 equivalent to the random number is awarded to the player who claims to have operated the identified machine on the jackpot winning occasion.

30

Summary of Invention

The present invention aims to provide another alternative to known jackpot systems.

35 This invention in one aspect resides broadly in a method of controlling the operation of a plurality of interconnected poker machines in a controlling system in which a jackpot prize is awarded when a monetary accumulation related to the total monetary value played

through the poker machines in a given period of time reaches a jackpot value, the method including:-

providing players of the poker machines with machine readable player identification means;

5 recording the identity of players when operating a poker machine;

and identifying as the jackpot winning player that player identified by the player identification means used to operate the poker machine which when thus operated
10 causes the monetary accumulation to equal or exceed the jackpot value.

As in the prior art, the randomly generated number may be stored as a fixed number, a monetary value relating to each operation of each machines in the
15 system being accumulated in a counter and the accumulated counter compared with the fixed number.

However it is preferred that the method includes:-

storing a randomly generated number in jackpot data storage means, and

20 incrementing accumulator means to provide an accumulation of a jackpotting percentage of the monetary value played through the poker machines;

whereby the jackpot winning player is identified when the accumulation equals or exceeds the randomly
25 generated number.

It is also preferred that the method includes:-

polling the poker machines after a preselected time interval;

30 incrementing the accumulator means by the total of the jackpotting percentages of the monetary value played through the poker machines which were operated during the preselected time interval, and

35 if the accumulation equals or exceeds the randomly generated number, generating a random sequence of the individual jackpotting percentages of the monetary value played through each of the poker machines which were operated during the preselected time interval and in the random sequence sequentially adding each of the



jackpotting percentages to the accumulation at the beginning of the preselected time interval.

In an alternative embodiment, the method includes:-

5 storing a randomly generated number in data storage means, and

decrementing the data storage means each time a player operates one of the poker machines;

whereby the jackpot winning player is identified when the data storage means is decremented to zero.

10 The data storage means may be decremented by an amount which is a proportion of the amount required to operate the respective poker machine, but in a preferred embodiment the data storage means is decremented by a randomly generated monetary amount.

15 In another aspect this invention resides broadly in a control system for a plurality of interconnected poker machines in which a jackpot prize is awarded when a monetary accumulation related to the total monetary value played through the poker machines in a given period of
20 time reaches a jackpot value, the method including:-

machine readable player identification means for identifying players of the poker machines;

recording means for recording the identity of players when operating a poker machine;

25 and jackpot winner identification means for identifying as the jackpot winning player that player identified by the player identification means used to operate the poker machine which when thus operated caused the monetary accumulation to equal the jackpot value.

30 The system preferably includes:-

means for generating a random number;

data storage means for storing the randomly generated number.

35 In one preferred embodiment, the system includes:-
incrementing means to provide an accumulation of a jackpotting percentage of the monetary value played through the poker machines;

the recording means identifying the jackpot winning



player when the incrementing means equals or exceeds the random number.

In this embodiment it is also preferred that the system includes:-

5 polling means for polling the poker machines after a preselected time interval;

adding means for adding the total of the jackpotting percentages of the monetary value played through the poker machines which were operated during the preselected
10 time interval;

random sequence generating means for generating a random sequence of the individual jackpotting percentages of the monetary value played through each of the poker machines which were operated during the preselected time
15 interval if the accumulation equals or exceeds the randomly generated number, and

accumulator means for adding in the random sequence each of the jackpotting percentages to the accumulation at the beginning of the preselected time interval.

20 In an alternative embodiment, the system includes:-

decrementing means for decrementing the data storage means each time a player operates one of the poker machines;

the recording means identifying the jackpot winning
25 player when the data storage means is decremented to zero.

It is also preferred that the system includes means for generating a random monetary amount each time a player operates one of the poker machines, the
30 decrementing means decrementing the data storage means by the randomly generated monetary amount.

Description of Drawings

In order that this invention may be more easily
35 understood and put into practical effect, reference will now be made to the accompanying drawings which illustrate a preferred embodiment of the invention, wherein:-



FIG 1 is a schematic block diagram illustrating the prior art, and

FIGS 2 and 3 are schematic block diagrams illustrating alternative embodiments of the invention.

5

Description of Preferred Embodiment of Invention

As seen in FIG 2, a number of poker machines 20a, 20b ...20n are played by players (not shown) each of whom have player identification means 21a, 21b ...21n
10 which uniquely and positively identify them. The identification means may be in the form of secure access identity means such as the smart cards disclosed in Australian Petty Patent 658111.

A random number 22 is generated and stored (+) in
15 storage means 23 which are decremented (-) each time a player operates a poker machine 20. Each operation of the machine decrements the random number by either a fixed amount, or optionally as seen in FIG 2 by a random amount generated by a random number generator 24.

20 The identity of each player who operates a poker machine 20 is established by player identification means 21 and recorded in recording means 25 which records the identity of the player of each play of a machine.

When a zero (0) is detected in storage means 23,
25 recording means 25 identifies the player identification means 21 which was operated when storage means 23 was decremented to zero. A jackpot 26 is awarded to the player identified by the player identification means 21 thus identified by recording means 25.

30 Alternatively as seen schematically in FIG 3, a number of poker machines 30a, 30b ...30n are played by players (not shown) each of whom have player identification means 31a, 31b ...31n which uniquely and positively identify them. The identification means may
35 be in the form of secure access identity means such as the smart cards disclosed in Australian Petty Patent 658111.

The identity of each player who operates a poker

machine 30 is established by player identification means 31 and recorded in recording means 39 which records the identity of the player of each play of a machine.

Timing means 32 routinely generates a timing signal at brief intervals such as between three and ten seconds, whereupon polling means 33 polls poker machines 30a, 30b30n and determines whether the machines have been operated in the preceding time interval.

The jackpotting percentage of the amount used to operate each machine which operated in the preceding time interval is added in adder 34 and the total accumulated in accumulator 37. The total in accumulator 37 is then compared in comparator 38 with a random number 35 which has been generated and stored in storage means 36.

The polling, totalling and accumulating procedure continues at the end of each time interval until comparator 38 determines that the total in accumulator 37 equals or exceeds the random number 35 in storage means 36.

When comparator 38 determines that the total in accumulator 37 equals or exceeds the random number 35 in storage means 36, the individual jackpotting percentages of the amounts used to operate each machine which was operated in the preceding time interval are randomly sequenced in random sequencing means 40, and in the randomly determined sequence each individual jackpotting percentage is sequentially added in accumulator 41 to the accumulated total at the beginning of the preceding time interval. The sequentially increasing accumulating total in accumulator 41 is sequentially compared in comparator 42 with the random number 35 in storage means 36.

A jackpot 43 is awarded to the player identified by the player identification means 39 as the player whose jackpotting percentage in the above sequential addition caused the accumulated total in accumulator 41 to equal or exceed the random number 35.

In use in accordance with the jackpot system of the present invention, a number of poker machines in a number

of clubs are interconnected. The system generates a random number between settable upper and lower limits and stores this random number in memory. The upper and lower limits of the random number to be generated are stored in
5 non-volatile memory. The random number represents a monetary value in dollars and whole cents.

When players operate a poker machine on the jackpot system, a jackpot percentage of their stake will accumulate in a jackpot accumulator. When the
10 accumulated amount exceeds the randomly generated number, a jackpot equivalent to the randomly generated number is awarded.

In the jackpot system, the accumulated total is not incremented on each individual occasion a player operates
15 a poker machine connected to the system. Rather, every ten seconds (or lesser time interval depending on system programming) the machines in the system are polled and the total of the jackpot percentages of the machines operated during the preceding ten second interval is
20 added to the total of the jackpot accumulator at the commencement of the ten second interval.

The new total may be either less, equal or greater than the random number.

If the new total is less than the random number, the
25 jackpot accumulator is then incremented by the total of the jackpot percentages of the machines operated during the preceding ten second interval. The new updated total of the jackpot accumulation then becomes the figure to which the total of the jackpot percentages of the
30 machines operated during the next ten second interval will be added at the end of that ten second interval.

If the new total is equal to or greater than the random number, a process begins to determine the winner of the jackpot. The winner of the jackpot is not
35 necessarily the player whose machine in real time sequence would have incremented the jackpot total to equal or exceed the random number. Indeed, the jackpot accumulator is not incremented in timed sequence by

signals from individual machines but rather, as described above, by aggregated increments at ten second intervals.

The winner of the jackpot is determined by sequentially adding to the total of the jackpot accumulation at the beginning of the ten second period, those individual player percentages of individual plays of individual machines which in total during the ten second interval caused the jackpot accumulation to equal or exceed the random number. However these individual player jackpotting percentages are not added in the real time sequence in which they were actually generated, but rather in a sequence which is itself randomly generated - this random sequence being varied every ten minutes.

The winner of the jackpot is the player identified by the smart-card which has necessarily been used to play in the jackpot system, as being the player whose individual jackpotting percentage, when added to the progressive total of the jackpot accumulator in the order of this randomly generated sequence, causes the progressive total to equal or exceed the random number.

During the currency of each jackpot, display means in each room/club display the progressive total of the jackpot accumulator. The jackpot system stores the identity of the machine being played by the player identified by the smart-card as the jackpot winner. When the jackpot is won, the display means displays the amount of the jackpot which has been won, the identity of club with the machine used by the winning player and the winning player's club badge number. The display means does not display the identity of the machine used by the winning player.

It will be appreciated that while the system outlined above is itself an inventive alternative to prior art systems, the present invention of identifying the player rather than the machine can be implemented in the jackpot system of the prior art.

The system and method of the present invention has a number of advantages over known poker machine jackpot

systems and methods.

By identifying the jackpot winning person rather than the jackpot winning machine, the present invention positively and uniquely identifies the player associated with the jackpot rather than the machine associated with the jackpot thereby avoiding disputes which occur in present systems as to which player was actually operating the jackpot winning machine.

Because there is a predetermined finite polling time of only a few seconds, or less depending on the power of the controlling system, there is virtually no delay in announcing and displaying the details of the winner of the jackpot. (This is usually done by club or badge number for reasons of confidentiality.) This contrasts with known systems which do not poll the machines and in which the updating occurs for every operation of the machine on the system and can generate delays of perhaps 3 or 4 minutes before the jackpot is actually notified as having been won. During this time, the actual player of the machine which triggered the jackpot may have disappeared. This coupled with the known system of nominating the jackpot machine rather than the player can lead to confusion, disruption and in some instances, altercations and legal action.

In one preferred aspect the present invention decrements a randomly generated number thereby avoiding the prior art systems of storing a fixed number, accumulating operations in a counter and comparing the accumulated counter with the fixed number on every operation of every machine in the system.

Furthermore, in another preferred aspect of the invention a random amount is generated to decrement the randomly generated number, thereby introducing into the system an increased level of anticipation because the speed with which the jackpot is approached is random - rather than as with present systems being merely a function of how many people are playing the machines in the system. The fact that the originally randomly

generated number does not remain fixed but is itself varied randomly, furthermore reduces the potential for jackpot rigging.

It will of course be realised that whilst the above
5 has been given by way of an illustrative example of this invention, all such and other modifications and variations hereto, as would be apparent to persons skilled in the art, are deemed to fall within the broad scope and ambit of this invention as is herein set forth.

Claims

1. A method of controlling the operation of a plurality of interconnected poker machines in a controlling system in which a jackpot prize is awarded when a monetary accumulation related to the total monetary value played through said poker machines in a given period of time reaches a jackpot value, said method including:-

5 randomly generating a number as the jackpot value;
10 polling said poker machines after a preselected time interval;

varying an accumulation of a jackpotting percentage of the monetary value played through said poker machines, the accumulation being varied by the total of the
15 jackpotting percentages of the monetary value played through the poker machines which were operated during said preselected time interval, and

if said varied accumulation equals or exceeds said randomly generated number, generating a random sequence
20 of the individual jackpotting percentages of the monetary value played through each of the poker machines which were operated during said preselected time interval and in said random sequence sequentially varying the accumulation at the beginning of the preselected time
25 interval by each of said jackpotting percentages;

whereby said jackpot is awarded when said accumulation sequentially equals or exceeds said randomly generated number.

30 2. A method as claimed in claim 1, said method including:-

providing players of said poker machines with machine readable player identification means;

35 recording the identity of players when operating a poker machine;

and identifying as the jackpot winning player that player identified by said player identification means used to operate said poker machine which when thus



operated causes said monetary accumulation to equal or exceed said jackpot value.

3. A method as claimed in claim 2, said method
5 including:-

storing said randomly generated number in jackpot
data storage means, and

adding to said accumulation a percentage of the
monetary value played through said poker machines;

10 whereby said jackpot winning player is identified
when said accumulation equals or exceeds said randomly
generated number.

4. A method as claimed in claim 2, said method
15 including:-

storing said randomly generated number in data
storage means, and

subtracting from said data storage means a
percentage of the monetary value played through said
20 poker machines;

whereby the jackpot winning player is identified
when said data storage means is decremented to zero.

5. A control system for a plurality of interconnected
25 poker machines in which a jackpot prize is awarded when a
monetary accumulation related to the total monetary value
played through said poker machines in a given period of
time reaches a jackpot value, said control system
including:-

30 means for generating a random number as a jackpot
value;

data storage means for storing said randomly
generated number;

35 polling means for polling said poker machines after
a preselected time interval;

accumulation varying means to vary an accumulation
of a jackpotting percentage of the monetary value played
through said poker machines, said accumulation varying



AMENDED SHEET
BUREAU

means varying the accumulation by the total of the jackpotting percentages of the monetary value played through said poker machines which were operated during said preselected time interval;

5 random sequence generating means for generating a random sequence of the individual jackpotting percentages of the monetary value played through each of said poker machines which were operated during said preselected time interval if said varied accumulation equals or exceeds
10 said randomly generated number, said accumulation at the beginning of said preselected time interval being varied in said random sequence by each of said jackpotting percentages;

wherein said jackpot is awarded when said
15 accumulation sequentially equals or exceeds said randomly generated number.

6. A control system as claimed in claim 5, said control system including:-

20 machine readable player identification means for identifying players of said poker machines;

recording means for recording the identity of players when operating a poker machine;

and jackpot winner identification means for
25 identifying as the jackpot winning player that player identified by said player identification means used to operate said poker machine which when thus operated caused said monetary accumulation to equal or exceed said jackpot value.

30

7. A control system as claimed in claim 6, said control system including:-

adding means for adding to said accumulation a percentage of the monetary value played through said
35 poker machines;

whereby said jackpot winning player is identified when said accumulation equals or exceeds said randomly generated number.



8. A control system as claimed in claim 7, said control system including:-

subtracting means for subtracting from said data storage means a percentage of the monetary value played
5 through said poker machines;

whereby said jackpot winning player is identified when said data storage means is decremented to zero.

9. A method of controlling the operation of a plurality
10 of interconnected poker machines in a controlling system in which a jackpot prize is awarded when a monetary accumulation related to the total monetary value played through said poker machines in a given period of time reaches a jackpot value, said method including:-

15 providing players of said poker machines with machine readable player identification means;

recording the identity of players when operating a poker machine;

and identifying as the jackpot winning player that
20 player identified by said player identification means used to operate said poker machine which when thus operated causes said monetary accumulation to equal or exceed said jackpot value.

25 10. A control system for a plurality of interconnected poker machines in which a jackpot prize is awarded when a monetary accumulation related to the total monetary value played through said poker machines in a given period of time reaches a jackpot value, said control system
30 including:-

machine readable player identification means for identifying players of said poker machines;

recording means for recording the identity of players when operating a poker machine;

35 and jackpot winner identification means for identifying as the jackpot winning player that player identified by said player identification means used to operate said poker machine which when thus operated



PCT/AU 97/00706
RECEIVED 10 AUG 1998

15

caused said monetary accumulation to equal said jackpot value.



AMENDED SHEET
IP/AU

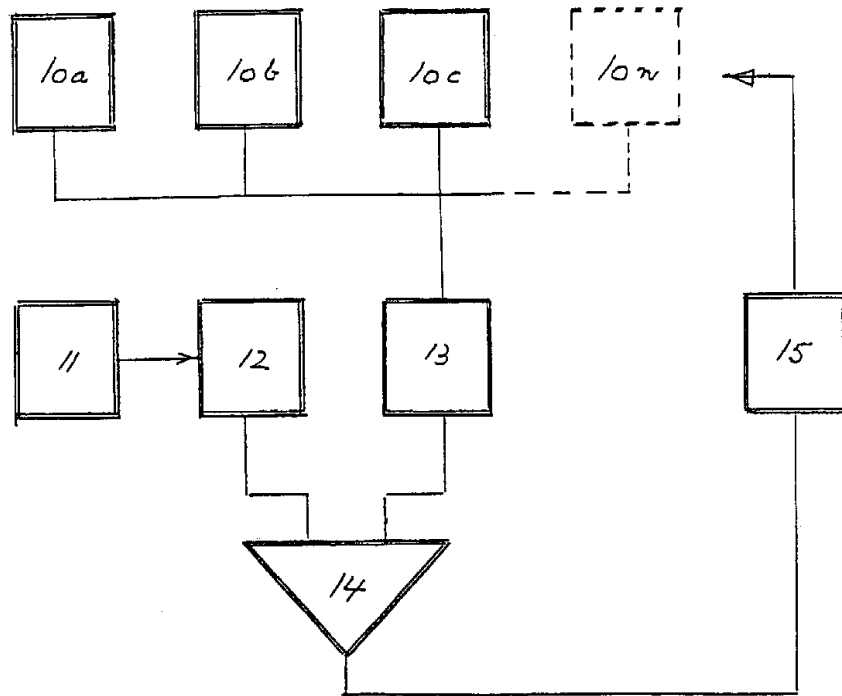

FIG 1

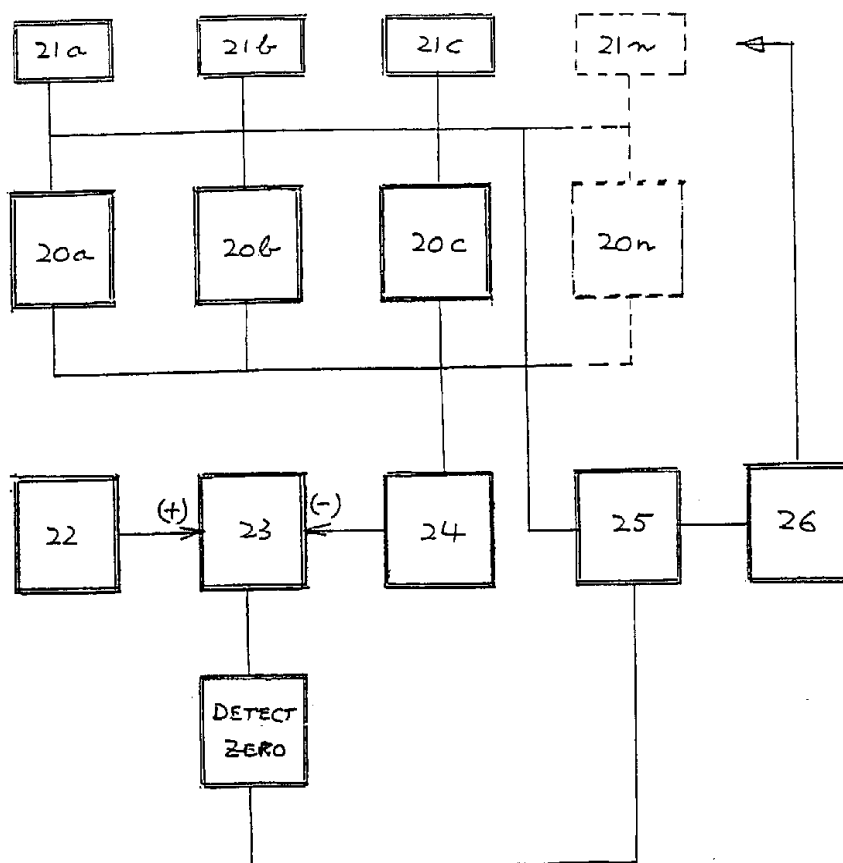

FIG 2

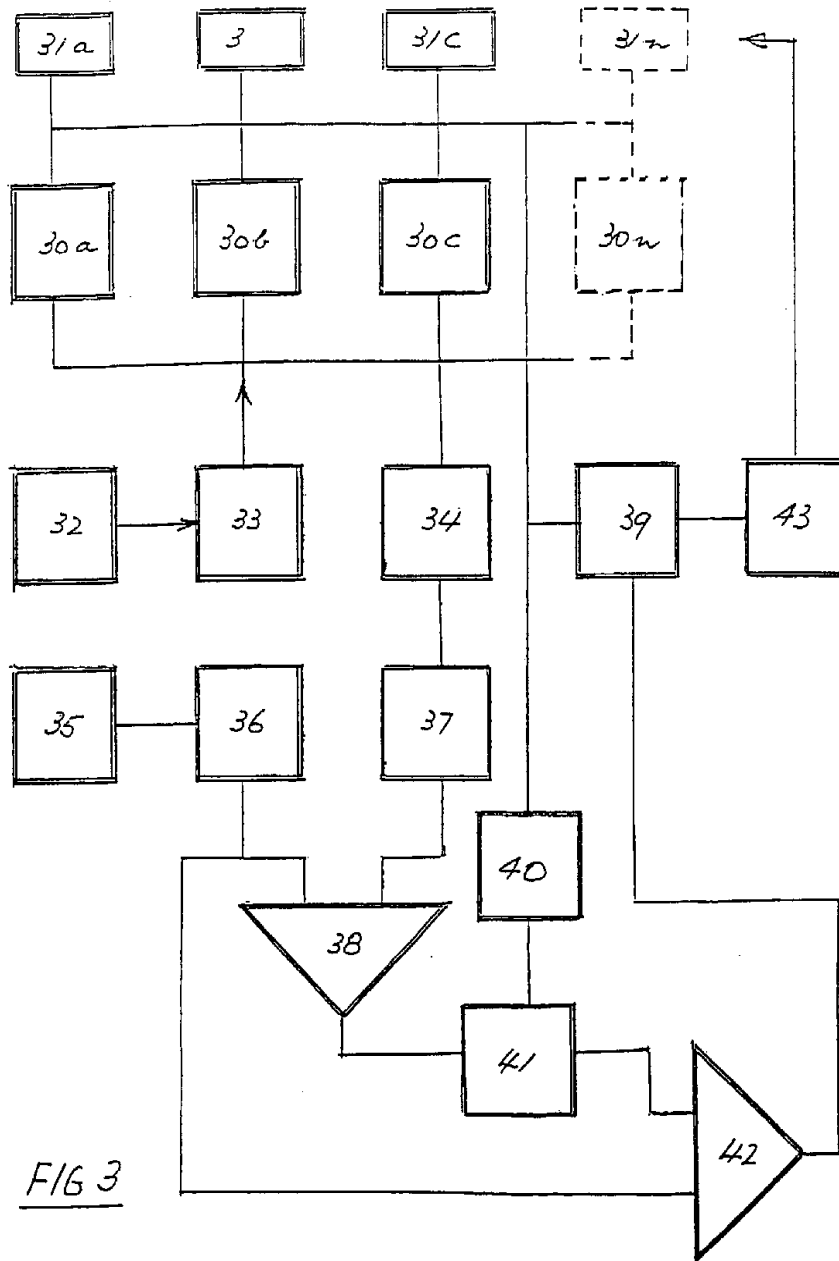

FIG 3