

Oct. 31, 1950

J. A. RUBICO
LAST

2,528,082

Filed Jan. 7, 1950

3 Sheets-Sheet 2

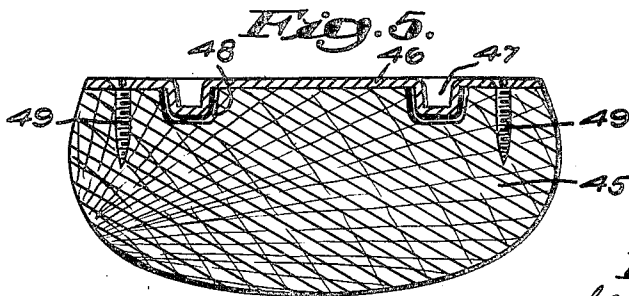
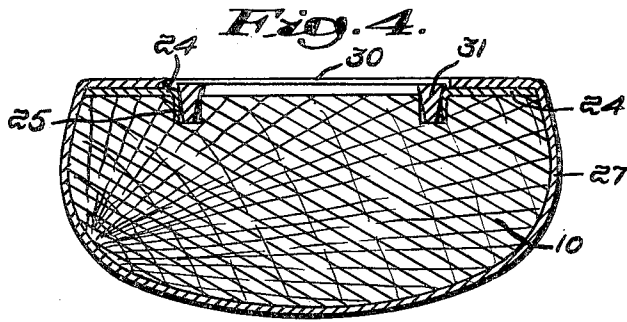
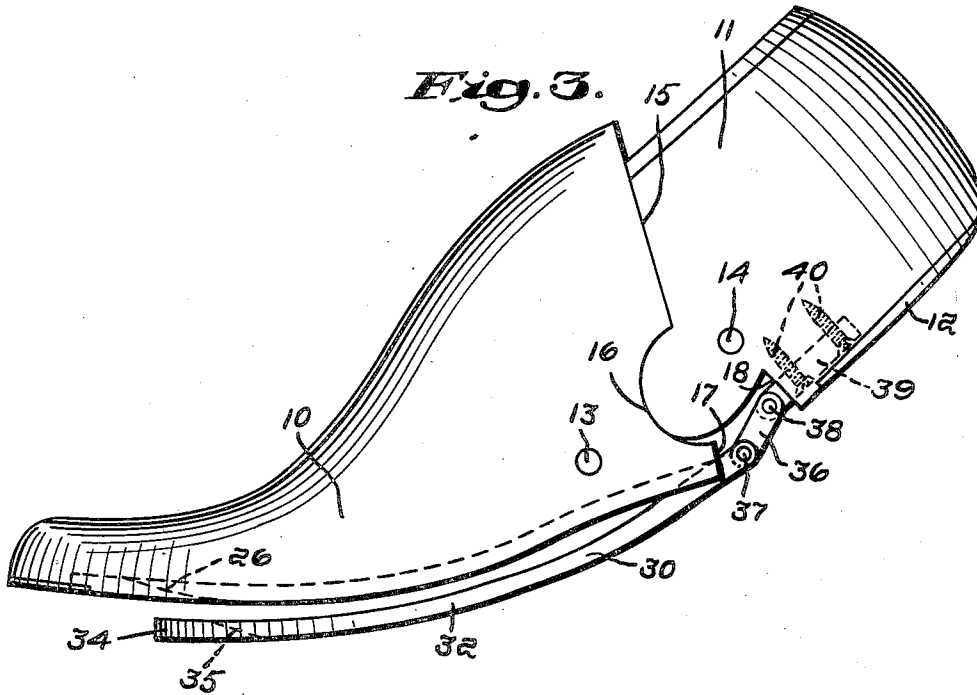

Inventor:
Jerome A. Rubico
by *James R. Hodder*
Attorney

Oct. 31, 1950

J. A. RUBICO

2,528,082

LAST

Filed Jan. 7, 1950

3 Sheets-Sheet 3

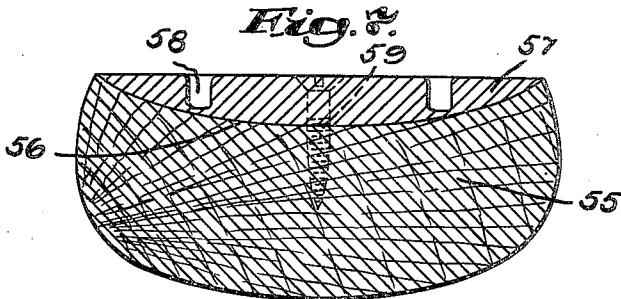
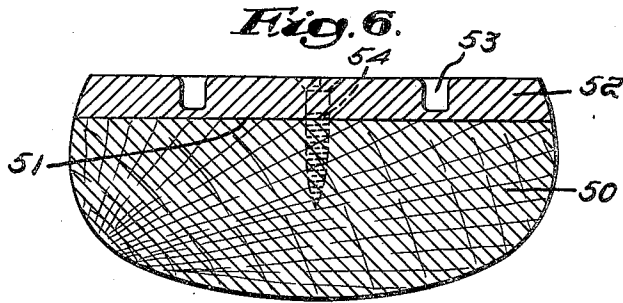

Inventor:
Jerome A. Rubico
by James R. Hodder
Attorney

UNITED STATES PATENT OFFICE

2,528,082

LAST

Jerome A. Rubico, East Boston, Mass., assignor to
Jerome Rubico, Inc., Boston, Mass., a corpora-
tion of Massachusetts

Application January 7, 1950, Serial No. 137,370

8 Claims. (Cl. 12-141)

1

My present invention relates to a novel and improved last for use in the manufacture of boots, shoes, and other footwear, and represents a further development in this art of the construction shown in my co-pending application Ser. No. 91,927, filed May 7, 1949.

In such prior application I preferred to employ a unique last formed with a central recess throughout the bottom thereof whereby the intermediate portion of a thin insole element attached to the upper, and lasted thereon, may be more readily cut out and removed, thus enabling me to eliminate the insole per se, and to produce a completely flexible shoe.

In furthering the development of my novel flexible single-sole footwear and appropriate lasts therefor, I have discovered that as well as cutting out the central portion of the last bottom, I can effect equally satisfactory results by forming a narrow groove in the bottom of the forepart of the last and providing a cooperating clamp secured to the last to operate therein.

I propose to form this groove throughout the entire forepart of the last substantially parallel to the edge of the last bottom and spaced inwardly from said edge a sufficient distance to provide a suitable area between the groove and the bottom edge portion to permit the laying thereof of an insole element or strip, preferably prepared with the inner edge thereof appropriately flanged to lay in the groove.

As thus assembled, my novel clamp, which is secured to the last heel part and of appropriately hinged construction to allow ready engagement and disengagement with its cooperating groove, is moved into clamping position, thereby contacting the insole element flange and retaining the same against dislodgment during the ensuing cement or other lasting operation uniting the upper and the insole strip.

To the upper and insole strip thus united, I may readily cement an outsole, or, if desired, I may prefer to prepare my novel insole strip with a sewing rib and attach thereto by inseam stitching a standard plastic or leather welt before applying the outsole, thus, in effect, enabling me to provide a welt shoe with the usual insole eliminated, so that the resulting footwear will be of completely flexible construction.

In preparing the forepart of my novel last, I find that I may utilize any standard type of last by milling a slot or groove around the forepart thereof; or by applying a thin metal stamping suitably grooved to a last bottom which has been roughly hollowed out to permit the housing of

2

such grooved portion, or, if desired, by forming a specially grooved plate which may be molded to fit snugly on an appropriately reduced last bottom either prepared flat or with a concave surface, and then secured thereto. In the latter case, I may prefer to employ any suitable light metal such as aluminum, magnesium, or the like, or an alloy thereof, so that the weight of my last will not be substantially greater than that of the standard wooden types.

It will also be appreciated that my novel arrangement may be applied to any existing or previously used lasts, so that any manufacturer desiring to adopt my process may, if desired, have its worn lasts renewed to include my grooved construction.

A prime object of my invention, therefore, is to provide a new and improved last construction on which I am enabled to make universally flexible footwear of the single-sole type and on which may be lasted shoes of "Welt" construction, "McKay" type shoes, and stapled footwear made by the "Littleway" process.

Another chief object of my invention pertains to the unique construction of my last bottom with its forepart groove and the cooperating hinged clamping member pivotally secured in its heel part, whereby a thin marginal strip may be utilized in uniting the upper and outsole in place of the usual insole, with the result that the main deterrent to footwear flexibility is eliminated.

Further important objects of my invention relate to the provision of a last whereby numerous operations in shoe manufacture may be dispensed with, much material saved, and a subsequent savings in cost effected.

Still further features, advantages, and improvements of my novel last will be hereinafter more fully pointed out in the accompanying description and more clearly defined in the appended claims.

Referring to the drawings illustrating a preferred embodiment of my novel last invention:

Figure 1 is a plan view showing the bottom of my novel last with a section of an insole strip laid thereon and illustrating my clamp member in inoperative position;

Fig. 2 is a plan view, similar to Fig. 1, but illustrating the clamp member in operative or clamped position;

Fig. 3 is a side elevational view of my last;

Fig. 4 is a cross-sectional view on the line 4-4 of Fig. 2 with the shoe upper shown added in cement-lasted relation;

Fig. 5 is a cross-sectional view of a modifica-

tion showing a thin metal stamping secured to the bottom of the last forepart;

Fig. 6 is a cross-sectional view of a further modification showing a metal casting attached to the bottom of the last forepart, and

Fig. 7 is a cross-sectional view of a still further modification wherein the casting shown in Fig. 6 is convex in form and applied to a hollowed out last forepart.

It will be appreciated that my novel last may be of any particular style and size or that my invention may be applied to any existing last, but for illustrative purposes, as shown in the drawings, I have indicated a last having a forepart 10 and a heel part 11 including a usual heel plate 12, the two parts 10 and 11 connected by a hinge (not shown) which is secured in the forepart 10 by a pin 13 and in the heel part 11 by a pin 14. Between the forepart 10 and the heel part 11 is shown a typical construction embodying a line of cut 15, a knuckle joint 16, and cooperating bottom face portions 17 and 18.

As shown in Figs. 1 and 2, my invention is incorporated in the last bottom and consists essentially in the formation of a narrow groove 20 in the forepart 10 extending substantially parallel to the bottom edge thereof and a cooperating clamp member 30 secured in the heel part 11 and adapted to be swung into and out of wedging association with said groove 20.

I prefer to mill or otherwise form such groove 20 around the forepart bottom 10, suitably spaced from the edge thereof to provide a marginal area 22 therebetween of suitable width for the laying thereon of an insole strip or element 24. This insole strip 24 may be prepared from any suitably strong and pliable material, such as leather or synthetic plastic, and is flanged about the inner edge, as at 25, to appropriately depend in the groove 20. As thus arranged on the last, the strip 24 is in position for lasting with a prepared upper 27.

In order to simplify the removal of the last upon completion of the lasting operations, I desire to widen the groove 20 at the toe portion thereof by appropriately bevelling the last bottom adjacent thereto, as shown in Figs. 1 and 2 at 26. I may reinforce the toe portion of the last, between the groove 20 and the outer contour of the sole by the attachment of a plate, attached by screws, as shown in Fig. 1.

My cooperating clamp, designated generally at 30, and being of substantially similar configuration to the groove 20 and being formed with a wedge-shaped depending rib 31 to seat in the same, comprises a pair of bowed arms 32 and 33 converting at their closed end into a bevelled toe plate 34, the under surface 35 of which affords a finger lift to facilitate the lifting of the clamp 30 from the groove 20 preparatory to the use of the last and also cooperates with the bevelled portion 26 in allowing ready withdrawal of the clamp and the last during the removal of the last from the shoe. The heel ends of the arms 32 and 33 are connected in freely pivotal association with the forward end of a link member 36 thru the medium of a pivot pin 37, the other end of which link 36 being, in turn, pivoted on a pin 38 to a forked plate 39, which is suitably secured by means of screws 40-40 in the last heel part 11 thru the face 18 and under the heel plate 12 thereof.

In Figs. 5, 6, and 7 I have shown three modifications of my novel last construction, wherein a separate grooved sheet or plate is pre-formed

or molded and then attached to the forepart bottom as a permanent part thereof.

With reference to Fig. 5, I show a last forepart 45 formed with a portion of the bottom thereof approximating a groove roughly hollowed out, as at 48, and extending in substantially parallel relation to the edge of such bottom. Upon the bottom surface of such forepart, thus formed, and coinciding exactly in size thereto, is a relatively thin plate 46 made of any light metal which may conveniently be stamped out and which is suitably grooved in the form of a depending rib 47. Such plate 46 is readily applied to the bottom of the forepart 45 with the rib 47 suspended in the grooved portion 48 and the two parts permanently attached by a plurality of screws 49-49.

In Fig. 6 I provide a last forepart 50 appropriately reduced in height and having the bottom thereof squarely cut, as at 51, to present a flush surface for a close union therewith of a plate 52, preferably molded of a suitably light metal, such as aluminum, magnesium or the like, and of sufficient thickness to permit a groove 53 to be formed therein. The plate 52 may be secured to the bottom of the last 50 by any suitable means, such as one or more screws 54.

Referring to Fig. 7, I utilize a last forepart 55 which is turned with a concave bottom portion 56 to provide an efficient surface for the seating thereon of the convex bottom of a cooperating plate 57, preferably moulded of any suitably light metal, such as aluminum, magnesium, or the like.

The plate 57 is of sufficient thickness to allow the formation therein of a groove 58, extending about the plate 57 in substantially parallel relation to the edge thereof, and may be permanently secured to the forepart 55 by any suitable means, such as one or more screws 59.

In the modifications shown in Figs. 5, 6, and 7 wherein I apply a stamped-out or molded metal plate having a pre-formed groove therein to the forepart bottom of the last, I find that more uniformly sized and shaped groove is provided and that the insole strip is, therefore, more effectively secured by the wedging action of the cooperating clamping member during the last operation. Thus, by providing a metal groove and a metal clamp, I am enabled to obtain particularly efficient and uniform interlocking action between such two parts and to eliminate the possibilities of damage thru wear to the wooden groove, or of change of size thereof thru constant swelling and shrinking due to the alternate wetting and drying to which the same may be subjected.

I have also discovered that by using the constructive showing in Fig. 7, I may effect the concave turning of the last forepart bottom with any standard last-turning equipment. This is believed to be an important feature of this modification.

In employing my novel last in the manufacture of flexible footwear, the insole strip or element 24 is placed about the marginal border 22 with the flange 25 suitably fitted in the groove 20, and the clamp 30 swung into operative clamping position, with the toe portion 36 and the rib 31 in wedging relation with the flange 25 so that the strip 24 is securely held against dislodgment. The ends of the strip 24 are then cemented or otherwise attached to a heel seat or heel and instep portion, the prepared upper lasted thereto, the outsole applied, and the last thereupon withdrawn.

5

As the last is broken for withdrawal, the double hinge construction provided by the link 35 operates to release the clamp 30 and complete withdrawal facilitated by the cooperating bevels 25 and 35.

From the foregoing, therefore, it will be seen that I have devised a novel last for use in the manufacture of flexible footwear, whereby the insole, as such, may be eliminated and in its place a narrow strip or welt-like piece utilized between the upper and the outsole. As my last construction is believed to be completely novel and a distinct improvement in this art, I have, accordingly, claimed the same hereinafter broadly.

I claim:

1. As an improved article of manufacture, a last comprising a forepart and a heel part and means connecting said parts, a groove formed on the bottom of said forepart and extending thereabout, and clamping means of similar contour to cooperate and engage with said groove.

2. As an improved article of manufacture, a last comprising a forepart and a heel part and means connecting said parts, a groove formed in the bottom of said forepart, a marginal lasting border around said groove and hinged clamping means secured in said heel part of similar contour to that of said groove, and constructed and arranged to swing into and out of cooperative engagement with said groove.

3. As an improved article of manufacture, a last comprising a forepart and a heel part and means connecting said parts, a groove formed in the bottom of said forepart, a marginal lasting border around said groove and hinged clamping means secured in said heel part, said clamping means consisting of a clamp of similar contour to said groove having the heel portion thereof pivoted to one end of a link member, the other end of said link member being pivoted to the forward end of a plate, the rear end of which plate is secured in said heel part.

4. As an improved article of manufacture, a last comprising a forepart and a heel part and means connecting said parts, a groove formed in the bottom of said forepart, a marginal lasting border around said groove and hinged clamping means secured in said heel part, said clamping means consisting of a clamp of similar contour to said groove and formed with a depending

6

rib to seat in said groove, said clamp having the heel portion thereof pivoted to one end of a link member, the other end of said link member being pivoted to the forward end of a plate, the rear end of which plate is secured in said heel part.

5. As an improved article of manufacture, a last comprising a forepart and a heel part, and means connecting said parts, a groove formed in the bottom of said forepart and merging into a bevelled recess at the toe portion thereof, and a clamp secured in said heel part of similar contour to said groove, and having a reinforced toe portion with the under surface thereof bevelled to cooperate with said bevel on said forepart whereby said clamp may readily be removed from the groove upon the breaking of the last.

6. As an improved article of manufacture, a last comprising a forepart and a heel part, and means connecting said parts, the bottom of said forepart formed with a prepared surface, a plate having a corresponding prepared bottom secured on said forepart bottom, a pre-formed groove in said plate and hinged clamping means secured in said heel part of similar contour to said groove constructed and arranged to be embedded in said groove.

7. As an improved article of manufacture, a last comprising a forepart and a heel part, and means connecting said parts, the bottom of said forepart formed with a concave surface, a plate having a correspondingly convex bottom secured on said forepart bottom, a pre-formed groove in said plate and hinged clamping means secured in said heel part of similar contour to said groove constructed and arranged to be embedded in said groove.

8. As an improved article of manufacture, a last comprising a forepart and a heel part, and means connecting said parts, the bottom of said forepart formed with a prepared surface, a plate having a corresponding prepared bottom secured on said forepart bottom, a pre-formed groove in said plate and hinged clamping means secured in said heel part of similar contour to said groove formed with a depending rib and constructed and arranged to be embedded in said groove.

JEROME A. RUBICO.

No references cited.