

---

**(12) PATENT ABRIDGMENT (11) Document No. AU-B-26834/88**  
**(19) AUSTRALIAN PATENT OFFICE (10) Acceptance No. 623870**

---

(54) Title  
**INTRAMEDULLARY INTERTROCHANTERIC FRACTURE FIXATION APPLIANCE AND FITTING DEVICE**

International Patent Classification(s)

(51)<sup>4</sup> **A61B 017/56**

(21) Application No. : **26834/88**

(22) Application Date : **14.12.88**

(30) Priority Data

(31) Number	(32) Date	(33) Country
<b>8729146</b>	<b>14.12.87</b>	<b>GB UNITED KINGDOM</b>
<b>8814920</b>	<b>23.06.88</b>	<b>GB UNITED KINGDOM</b>

(43) Publication Date : **15.06.89**

(44) Publication Date of Accepted Application : **28.05.92**

(71) Applicant(s)  
**HOWMEDICA INTERNATIONAL INC.**

(72) Inventor(s)  
**PETER LAWES; STEPHEN TAYLOR; PHILIP JOHN ADCOCK**

(74) Attorney or Agent  
**KELVIN LORD & COMPANY , 4 Douro Place, WEST PERTH WA 6005**

(56) Prior Art Documents  
**US 4865025**  
**EP 257118**  
**EP 187283**

(57) Claim

1. An intramedullary intertrochanteric fracture fixation appliance in combination with a removable fitting device therefor, said appliance comprising an intramedullary rod having proximal and distal ends and having an angulated opening in which is located a femoral neck screw, said rod having a co-axial bore extending from the proximal end of the rod and into said angulated opening, anti-rotation means located in said co-axial bore which can be actuated to act on and prevent rotation of said neck screw in said rod, clamping means which are located in the proximal end of said bore for clamping the removable fitting device to the proximal end of the intramedullary rod, and said clamping means acting to permit actuation of the anti-rotation means to act on the neck screw to prevent rotation thereof when the clamping means are acting to clamp the removable fitting device to the proximal end of the intramedullary rod.

**COMPLETE SPECIFICATION**

(ORIGINAL)

Application Number:  
Lodged:

FOR OFFICE USE:

623370  
Class

Int. Class

Complete Specification Lodged:  
Accepted:  
Published:

Priority:

Related Art:

Name of Applicant(s): HOWMEDICA INTERNATIONAL INC.

Address of Applicant(s): Shannon Industrial Estate, Shannon, Co. Clare,  
IRELAND.Actual Inventor(s): 1. PETER LAWES  
2. STEPHEN TAYLOR  
3. PHILIP JOHN ADCOCKAddress for Service: Kelvin Lord & Co.,  
4 Douro Place,  
WEST PERTH,  
Western Australia 6005.

Complete Specification for the invention entitled:

INTRAMEDULLARY INTERTROCHANTERIC FRACTURE FIXATION APPLIANCE  
AND FITTING DEVICE

This invention relates to an intramedullary intertrochanteric fracture fixation appliance and a removable fitting device for use with it.

Intramedullary intertrochanteric fracture fixation devices  
5 are known which comprise an intramedullary rod having an angulated opening to receive a femoral neck screw, which is sometimes provided in the form of a lag screw. The intramedullary rod is fitted in the intramedullary canal of the femur and the neck screw passes through an opening in  
10 the intramedullary rod, through the neck of the femur and into the head. With this kind of device it is possible to produce tension in the neck screw to pull the head and neck of the femur together and means can be provided to prevent the screw rotating both during this operation and in its  
15 final position. This can be provided by the provision of grooves in the neck screw into which a set screw can be located thus allowing the neck screw to slide but not rotate and when the procedure has been completed the set screw can be tightened up to hold the parts in a fixed  
20 position. Alternatively, some surgeons prefer to leave the set screw loose merely preventing rotation as required for the particular patient.

It is also known to provide a fitting device to assist in locating the various parts during the operation. Thus, the  
25 fitting device may be arranged to clamp to the upper end of the intramedullary rod and to provide a guide to enable a hole to be bored in the head of the femur to accept the neck screw. The guide can also remain in position to assist in guiding the compression screw whilst it is being



screwed into position. Such fitting devices can also provide guides for drilling holes further down the femur to allow location screws to be passed through the lower end of the intramedullary rod to locate it, but the fitting device prevents operation of the set screw to act on the neck screw whilst the fitting device is in position on the end of the intramedullary rod.

The fitting device has therefor to be removed to allow the set screw, or other means to hold the neck screw in position, to be operated and there is a tendency for the neck screw to unwind or move longitudinally in the intramedullary rod whilst the fitting device is being removed and before the set screw can be inserted, and an object of the present invention is to provide such an intramedullary intertrochanteric fracture fixation appliance which has provision for carrying out the operation of locking the neck screw and avoiding its becoming loosened or moving during the operation.

According to the present invention an intramedullary intertrochanteric fracture fixation appliance in combination with a removable fitting device therefore comprises an intramedullary rod having proximal and distal ends and having an angulated opening to receive a femoral neck screw, said rod having a co-axial bore extending into said angulated opening, anti-rotation means located in said co-axial bore which can be actuated to prevent rotation of said neck screw in said rod and the proximal end of said co-axial bore being provided with means for attaching said removable fitting device on the proximal end of the rod so



that said anti-rotation means can be operated with the fitting device attached thereto.

Thus, any operation of the anti-rotation means can take place with the fitting device still in position and the  
5 risk of the neck screw loosening is reduced.

There are also other advantages in as much that a guide means for guiding means for drilling the hole in the head and neck of the femur can also be left in position whilst the anti-rotation means are fitted.

10

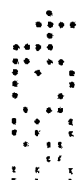

15

20

25



A further advantage is that the complete operation can be carried out and completed before removal of the fitting appliance and so that the operative steps are not divided up.

5

Preferably said anti-rotation means includes longitudinally extending grooves provided on said neck screw which can be engaged by a set screw located in said bore to prevent rotation of the neck screw or clamp it in position.

10

The removable fitting device can be provided with means for location in the co-axial bore, means allowing location of the set screw, and guide means for accurately guiding means for forming a hole in the femoral head of the user to receive said femoral neck screw.

15

Preferably the guide means include a tunnel locator.

20

One end of the tunnel locator can be adapted to engage and locate on the intramedullary rod.

25

The fixing device may also include a removable tension adjuster which extends through the tunnel locator for connection to the proximal end of the neck screw and has adjustment means for applying a tension to said screw.

30

The adjustment means can be arranged to engage the proximal end of the tunnel locator to apply a compression thereon between said adjustment means and the intramedullary rod.

35

Preferably the removable tension adjuster has means to engage driving means on the neck screw to drive it into position by rotation thereof by rotation thereof.



5 The removable tension adjuster can therefore comprise a screw driver with a hollow shaft, the distal end of said shaft having means to engage the neck screw to drive it into position and an operating handle, a tensioning adjuster extending axially through said hollow shaft, one end of said adjuster being screw threaded to engage a threaded bore on the end of the neck screw and the other end having an operating portion by which it can be rotated, the hollow shaft carrying a screw threaded adjuster which can act against the proximal end of the tunnel locator.

10

15 The removable fitting device can also be provided with means for guiding means for forming a hole or holes in the femur of the user to receive screws or pins to locate the distal end of the intramedullary rod.

20 Two of said set screws of different sizes for alternative use in the intramedullary rod, one screw being of a substantially plain configuration and the other having a flange which can engage abutment means on the intramedullary rod to locate its axial position so that it can enter the grooves in the neck screw but not lock it in position.

25 The invention also includes an intramedullary intertrochanteric fracture fixation appliance for use in the combination set forth above and which comprises an intramedullary rod having proximal and distal ends and having an angulated opening to receive a femoral neck screw, said rod having a co-axial bore extending into said angulated opening, anti-rotation means located in said co-axial bore which can be actuated to prevent rotation of said neck screw in said rod and the proximal end of said co-axial bore being provided with means for attaching said removable fitting device on the proximal end of the rod so that said

30

35



anti-rotation means can be operated with the fitting device attached thereto.

5 Preferably the anti-rotation means comprises an adjustable stop and the anti-rotation means may also be provided by the same stop.

10 The invention can be performed in many ways and two embodiments will now be described by way of example and with reference to the accompanying drawings in which :-

Figure 1 is a diagrammatic part cross-sectional view of the fracture fixation appliance and fitting device according to the invention;

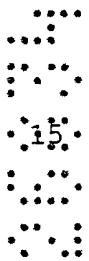

20



30

35





Figure 2 is a part cross-sectional side elevation of the device and appliance shown in Figure 1 showing the various parts ready for assembly;

Figure 3 is an enlarged cross-sectional view of part of the fixation appliance and fitting device shown in Figures 1 and 2.

Figure 4 is a part sectional cross-sectional side view of an alternative form of fracture fixation appliance; and,

Figure 5 is a cross-sectional view of the neck screw on the line IV-IV of Figure 4.

As shown in Figures 1, 2 and 3 of the drawings the intramedullary intertrochanteric fracture fixation appliance comprises an intramedullary rod 1 for introduction into the intramedullary canal of a femur. As is most clearly shown in Figure 3 the intramedullary rod has an angulated opening 2 and a co-axial bore 3 which opens into the angulated opening 2 and in which is located anti-rotation means in the form of a set screw 4.

Located in the angulated opening 2 is a femoral neck screw 5 in the form of a lag screw, one end of which carries a coarse screw thread 6 and which is provided with four longitudinally extending grooves 7. The lower end of the set screw 4 is provided with a location boss 8 which is dimensioned so that it can engage one of the grooves 7 and thus prevent rotation of the neck screw 5 when the set screw is in the position shown in Figures 1 and 3. In order to receive set screw 4 the bore 3 is screw threaded at 9 and the upper end of the bore indicated by reference numeral 10 is of enlarged diameter and is also screw threaded at 11. The proximal end of the intramedullary rod is provided with two radially extending slots 12 to receive and locate a fitting device indicated by reference numeral 13 and the distal end of

the rod is provided with two holes 14 and 15 to receive pins or screws to fix and locate that end of the rod in the bone.

The proximal end of the neck screw 5 is provided with driving means in the form of circumferentially opposed slots 20 and is formed with a bore 21 which is screw threaded at 22 to receive a removable tension adjuster to be described hereunder.

The fitting device 13 comprises an angulated arm 25 one end of which carries a boss 26 the lower end of which is provided with pegs 27, as is most clearly shown in Figure 2, and which are shaped to engage in the slots 12 in the proximal end of the intramedullary rod 1. A securing bolt 28 is provided the shank 29 of which is a close sliding fit in a bore 30 in the boss 26. The securing bolt 28 has a stepped bore 31 the upper enlarged end of which is screw threaded at 32. The lower end of the shank 29 also carries an external screw thread 33 which is adapted to engage with the screw thread 11 in the bore 10 of the rod 1 so that the boss 26 can be firmly clamped to the upper end of the intramedullary rod 1 and held against rotation by the pegs 27.

The other end of the angulated arm 25 carries a guide block 35 which is provided with an angulated bore 36 and two further alignment bores 37 and 38. The positioning of the bore 36 is arranged so that when the fitting device is clamped in position on the rod 1 the bore 36 is accurately aligned with the angulated hole 2 in the rod 1. Similarly the bores 37 and 38 are aligned with the holes 14 and 15 in the rod 1.

Also provided are three tunnel locators. The locator for the angled bore 36 comprises a tubular portion 40 one end of which carries a flange 41 and the other end of which is shaped as shown at 42 to engage the circumferential shape of the rod 1 in close alignment and so that it is held against rotation. The other tunnel locators 45 and 46 also consist of tubes 47

with flanged ends 48. As will be seen from Figure 1 the tunnel locators can be positioned in the bores 36, 37 and 38 in the guide block 35 and are removable slide fits therein. The length of the locators is arranged so that they can extend from the guide block 35 up to and in engagement with the intramedullary rod 1.

A removable tension adjuster is provided which can extend through the tunnel locator 40 for connection to the proximal end of the neck screw 5 and adjustment means are provided for applying a tension to the screw when it is in position in the bone in order to enable the fractured portion to be pulled into close proximity with the remainder of the bone. The tension adjuster comprises a hollow screw driver 50 which has a hollow handle 51, a hollow shank 52 and a substantially cruciform shaped end 53 which can engage in the slots 20 in the end of the compression screw so that the screw 5 can be turned. The outer circumference of the shank 52 is screw threaded at 54 and carries a hand wheel 55. Extending axially through the screw driver 50 is a tensioning adjuster in the form of a tubular rod 56 one end of which is screw threaded at 57 and the other end of which is provided with a boss 58 by which the rod may be rotated. The rod is free to slide axially within the screw driver 50 and a portion of the rod is provided with an upstanding screw thread 59 which can be screwed through a co-operating screw thread 60 provided in a bore in the distal end of the handle 51. The length of the rod 56 is arranged so that the screw thread 57 can protrude from the end of the shank 52 with the boss 58 located against the end of the handle. Four arrows 61 are marked on the diametrically opposed sides of the handle 51 for reasons to be described hereunder. The shank 52 is an accurate sliding fit in the bore of the tunnel locator 40.

The thread 59 of the rod 56 prevents the rod falling out of the screw driver but when it is desired to remove the rod for sterilization purposes it is merely necessary to withdraw

it until the screw thread 59 engages the screw thread 60 and then rotate it until the rod is free.

A further screw driver 70 is also provided and which has a suitably shaped end to engage a socket 71 provided in the end of the set screw 4.

A location rod (not shown) is also provided in the form of a simple length of circular rod of the same diameter as the neck screw 5, one end of the rod being bent over to form an arm. The use of this rod will be described later.

When the operation is to be carried out the intramedullary rod 1 is located in the intramedullary canal of the femur in the usual way and the fitting device 13 is placed in position by engaging the pegs 27 in the slots 12 and inserting the securing bolt 28, the thread on the bolt engaging the thread in the upper end of the bore in the rod and thus clamping the fitting device against rotation or rocking movement. The tunnel locator is now placed in position in the bore 36 and a hole is bored through the femur, the neck of the femur and into the head thereof to receive the femoral neck screw 5. The tunnel locator therefore acts as a guide. During this part of the operation the fractured neck or head of the femur can be displaced and it is necessary to draw it into engagement with the remainder of the bone. In order to achieve this the set screw 4 is inserted down the bore of the bolt 28 so that its screw thread 9 engages the screw thread in the lower end of the bore 3. The length of rod (not shown) previously referred to is now inserted into the tunnel locator so that it extends into the opening 2 and the set screw 4 is advanced until it touches the rod. The surgeon now knows that the end of the set screw is approximately in line with the surface of the opening 2. The neck screw is now screwed into position by operating the screw driver 50, its cruciform end engaging the slots 20 in the end of the screw, and the arrows 61 on the screwdriver are used to align one of the grooves 7

in the uppermost position. The set screw is now turned downwards with the screwdriver 70 until the lower end of the set screw is engaged within one of the grooves 7. Provided the screw is not tightened the neck screw now has the facility to slide in the opening 2 but is locked against rotation. With the neck screw 5 in this position the inner rod 56 of the screwdriver is now rotated by operating the knob 58 and so that the screw thread 57 at its distal end engages the screw thread 21 in the proximal end of the neck screw 5. With the inner rod 56 now held in position on the screw the hand wheel 55 is rotated so that it engages and acts against the flange 41 of the tunnel locator 40. As the other end of the locator engages against the rod 1 further movement of the hand wheel 55 will cause the whole screwdriver to be drawn outwardly taking with it the neck screw 5. As the neck screw is held against rotation by the set screw 3 it merely slides through the opening 2 and draws the head of the femur into close engagement with the rest of the bone. In certain circumstances it is not necessary to maintain the tension in the neck screw and it can be relaxed, the operation of drawing the bones together having been completed. Alternatively, it may be necessary to hold the bones together under tension and in order to achieve this the set screw 3 is now tightened down further so that it firmly holds the neck screw in position.

The screw driver can now be removed.

Before or after the previous operations the tunnel locators 45 and 46 can be used to accurately drill through the bone so that pins and/or screws can be inserted down them to locate the distal end of the rod 1.

The tunnel locators can also be used for controlling the position and angulation of guide wires, the drills, the taps and, as referred to above, the femoral neck screw or other screws.

Thanks to the construction of the securing bolt 28 it is possible to achieve all the necessary actions without removing the fitting device and thus it is not necessary to remove the tunnel locator before fully and finally fitting the implant. This has various advantages, firstly the femoral neck screw can be fully fitted and locked before moving on to fit the optional distal screws in the holes 14 and 15. There is always a risk that while the two distal locking screws are being fitted or while the tunnel locator is being removed the neck screw can rotate (with or without the femoral head also rotating) and this can prevent the set screw from correctly engaging the neck compression screw groove.

There are also advantages in completing the implantation and then removing the instrument rather than dividing up the operative steps.

The operating surgeon is given a number of choices; he can either tightly lock the assembly (so that neither sliding nor rotation of the neck screw can occur), or he can fit the set screw so that it allows sliding and prevents rotation.

As there will be a family of sizes of both intramedullary rods and neck screws it is difficult to standardise the distance from the upper end of the intramedullary rod to the neck screw and this poses a constraint on the standardisation of set screws.

It is impractical to provide for the surgeon to check the correct position of the locking screw by direct observation (visually or X-ray) or by feeling the top of said screw relative to the top end of the intramedullary rod. In order to do this it would inevitably be necessary to produce a family of set screws. Any error made in the operating theatre (wrong choice of screw size) or made by the manufacturer

(screw too short, too long) or incorrectly identified, would render the design non-foolproof.

A further feature of the present invention therefore is that it is possible to have one size of set screw only and which is fitted to the intramedullary rod 1 before the femoral neck screw is installed in the manner described above.

To recap this procedure therefore, firstly a rod corresponding to the diameter of the neck screw 5 is passed through the lateral femoral cortex (after reaming using the tunnel locator) and juts through the intramedullary rod. The set screw is now driven in until it jams against the rod. This position is determined when the rod will no longer freely rotate and it is for this reason that the end of the rod is provided with an arm. The set screw is now backed off approximately one turn to release the rod, the rod is removed, the appropriate femoral neck screw is connected and inserted in the manner described above and with one of the grooves 7 directly beneath the set screw. The set screw is now driven in more than one turn (depending on the choice of screw pitch) and it is then definitely engaging in the neck screw groove.

As described above, if desired the surgeon can drive the set screw a further turn to cause it to firmly jam in the groove 7 thereby locking the total assembly and preventing sliding.

If desired this type of set screw can have a Nylok pellet in the thread to prevent involuntary rotations when in service.

Although the above method of operation is practical and simple it does have the disadvantage that the surgeon must remember that after jamming the test rod with the set screw that he backed off one turn (say) then after installing the neck screw that he must drive the screw in two turns (say) to

allow sliding of the lag screw.

As an alternative a shoulder can be provided in the bore inside each size of intramedullary rod at a fixed height above the opening 2. This shoulder engages with a corresponding shoulder on a set screw of the type shown in Figure 2 where the shoulder is indicated by reference numeral 73. This shoulder is arranged at a suitable distance from the end 8 of the set screw so that when it engages the shoulder in the rod 1 the end of the screw protrudes into the opening 2 and, provided it is in a groove 7, has sufficient effect to prevent rotation of the neck screw but does not act to lock it in position against sliding. Thus, after installing the neck screw the set screw is merely driven down to the shoulder.

The remainder of the steps of the operation will be as set forth above to avoid the risk of a bone chip fouling said screw thread and causing the surgeon to believe mistakenly that the set screw was fully home.

With a set screw of this type however it will be appreciated that there is no provision for totally locking the assembly against sliding although it will lock it against rotation.

To overcome this difficulty a second set screw is provided which does not have a shoulder and which is slightly longer than the first set screw referred to above so that when it is screwed in to its full extent it locks in the groove 7 and not only prevents rotation but also prevents sliding. As the shoulder is not required on this second screw it is possible to design it to be visually different from the first, that is there is no shoulder, thereby reducing the risk of error by the manufacturer, surgeon or nurse in incorrectly identifying the required screw. If desired the screw with a shoulder can be simply labeled "sliding" whilst the slightly longer screw without the shoulder can simply be labeled "locking". A screw



without a shoulder is shown in Figure 1 and a screw with a shoulder in Figures 2 and 3.

Figures 4 and 5 show an alternative construction of fixation appliance but the same reference numerals are used to indicate similar parts to those shown in Figures 1, 2 and 3. In this construction the femoral neck screw 5 in the form of a lag screw is provided with four longitudinally extending ramp shaped grooves 7. As will be seen from the drawing the shallow ends 78 of the ramps, that is the deeper ends of the grooves 77 are towards the threaded end of the neck screw.

As will be seen the set screw 4 now acts not only as anti-rotation means but as an adjustable stop for limiting the length of sliding movement of the lag screw in relation to the rod. Thus, movement towards the left hand side of the drawing, that is in the direction of the screw threaded portion of the rod, by the screw is restricted by the set screw engaging the rising ramp in the slot 77 but, because the slot is angled away from the set screw, in the other direction, there is relative sliding movement between the parts in that direction.

The surgeon now has three choices, when the fractured femur has been drawn together the surgeon can screw down the set screw to cause it to firmly jam in the groove 77 thereby locking the total assembly and preventing sliding. Alternatively, the surgeon may merely allow the screw to lightly engage in the groove 77 thus allowing relative sliding movement between the parts but preventing turning. The third alternative is to screw the set screw 4 down until it engages the ramp, for example as shown in Figure 1 of the drawings. In this position relative movement between the parts is allowed when compression is applied to the bone fracture. This compression is therefore maintained when the fitting device 13 referred to above is removed. The neck screw is still free to move when body weight or muscle activity takes

effect on the hip joint but the set screw 4 limits the relative movement over a selected portion of the length of the neck screw.

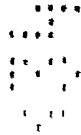

The claims defining the invention are as follows:-

1. An intramedullary intertrochanteric fracture fixation appliance in combination with a removable fitting device therefor, said appliance comprising an intramedullary rod  
5 having proximal and distal ends and having an angulated opening in which is located a femoral neck screw, said rod having a co-axial bore extending from the proximal end of the rod and into said angulated opening, anti-rotation means located in said co-axial bore which can be actuated  
10 to act on and prevent rotation of said neck screw in said rod, clamping means which are located in the proximal end of said bore for clamping the removable fitting device to the proximal end of the intramedullary rod, and said clamping means acting to permit actuation of the  
15 anti-rotation means to act on the neck screw to prevent rotation thereof when the clamping means are acting to clamp the removable fitting device to the proximal end of the intramedullary rod.
2. An intramedullary intertrochanteric fracture fixation  
20 appliance and fitting device as claimed in claim 1 in which said anti-rotation means includes longitudinally extending grooves provided on said neck screw which can be engaged by a set screw located in said bore to prevent rotation of the neck screw or clamp it in position.
- 25 3. An intramedullary intertrochanteric fracture fixation appliance and fitting device as claimed in claim 2 in which said removable fitting device is provided with means for location in the co-axial bore, means allowing location of the set screw, and guide means for accurately guiding means



for forming a hole in the femoral head of the user to receive said femoral neck screw.

4. An intramedullary intertrochanteric fracture fixation appliance and fitting device as claimed in claim 3 in which
- 5 said guide means include a tunnel locator.

10

10

15

15

20

25



5. An intramedullary intertrochanteric fracture fixation appliance and fitting device as claimed in claim 4 in which one end of said tunnel locator is adapted to engage and locate on the intramedullary rod.

5

6. An intramedullary intertrochanteric fracture fixation appliance and fitting device as claimed in claim 4 or claim 5 in which said fitting device includes a removable tension adjuster which extends through said tunnel locator for  
10 connection to the proximal end of the neck screw and has adjustment means for applying a tension to said screw.

15

7. An intramedullary intertrochanteric fracture fixation appliance and fitting device as claimed in claim 6 in which  
15 said adjustment means engage the proximal end of the tunnel locator to apply a compression thereon between said adjustment means and the intramedullary rod.

20

8. An intramedullary intertrochanteric fracture fixation appliance and fitting device as claimed in claim 7 in which  
20 said removable tension adjuster has means to engage driving means on the neck screw to drive it into position by rotation thereof.

25

9. An intramedullary intertrochanteric fracture fixation appliance and fitting device as claimed in claim 8 in which  
25 said removable tension adjuster comprises a screw driver with a hollow shaft, the distal end of said shaft having means to engage the neck screw to drive it into position and  
30 an operating handle, a tensioning adjuster extending axially through said hollow shaft, an end of said adjuster being screw threaded to engage a threaded bore in the end of the neck screw and the other end having an operating portion by  
35 which it can be rotated, the hollow shaft carrying a screw threaded adjuster which can act against the proximal end of the tunnel locator.



10. An intramedullary intertrochanteric fracture fixation  
appliance and fitting device as claimed in <sup>any one of</sup> claims 3 to 9 in  
which said removable fitting device is provided with means  
for guiding means for forming a hole or holes in the femur  
5 of the user to receive screws or pins to locate the distal  
end of the intramedullary rod.

11. An intramedullary intertrochanteric fracture fixation  
appliance and fitting device as claimed in any one of  
preceding claims 2 to 10 including two of said set screws  
10 but of different sizes for alternative use in the  
intramedullary rod, one screw being of a substantially  
plain configuration and the other having a flange which can  
engage abutment means on the intramedullary rod to locate  
its axial position so that it can enter the grooves in the  
15 neck screw but not lock it in position.

12. An intramedullary intertrochanteric fracture fixation  
appliance for use in the combination of claim 1, said  
appliance comprising an intramedullary rod having proximal  
and distal ends and having an angulated opening in which is  
20 located a femoral neck screw, said rod having a co-axial  
bore extending from the proximal end of the rod and into  
said angulated opening, anti-rotation means located in said  
co-axial bore which can be actuated to act on and prevent  
rotation of said neck screw in said rod, and the proximal  
25 end of said co-axial bore being provided with means for  
attaching said removable fitting device on the proximal end  
of the rod so that said anti-rotation means can be operated  
with the fitting device attached thereto.

13. An intramedullary intertrochanteric fracture fixation



appliance as claimed in claim 12 in which said anti-rotation means includes longitudinally extending grooves provided on said neck screw which can be engaged by a set screw located in said bore to prevent rotation of the neck screw or clamp it in position.

14. An intramedullary intertrochanteric fracture fixation appliance as claimed in claims 12 and 13, including two of said set screws but of different sizes for alternative use in the intramedullary rod, one screw being of a substantially plain configuration and the other having a flange which can engage abutment means on the intramedullary rod to locate its axial position so that it can enter the grooves in the neck screw but not lock it in position.

15. An intramedullary intertrochanteric fracture fixation appliance in combination with a removable fitting device substantially as described herein with reference to and as shown in Figures 1,2 and 3.

16. An intramedullary intertrochanteric fracture fixation appliance substantially as described herein with reference to and as shown in Figures 1,2 and 3.

25

DATED DECEMBER 4 1991

HOWMEDICA INTERNATIONAL INC

By their Patent Attorneys

KELVIN LORD AND COMPANY

PERTH, WESTERN AUSTRALIA



26834/88

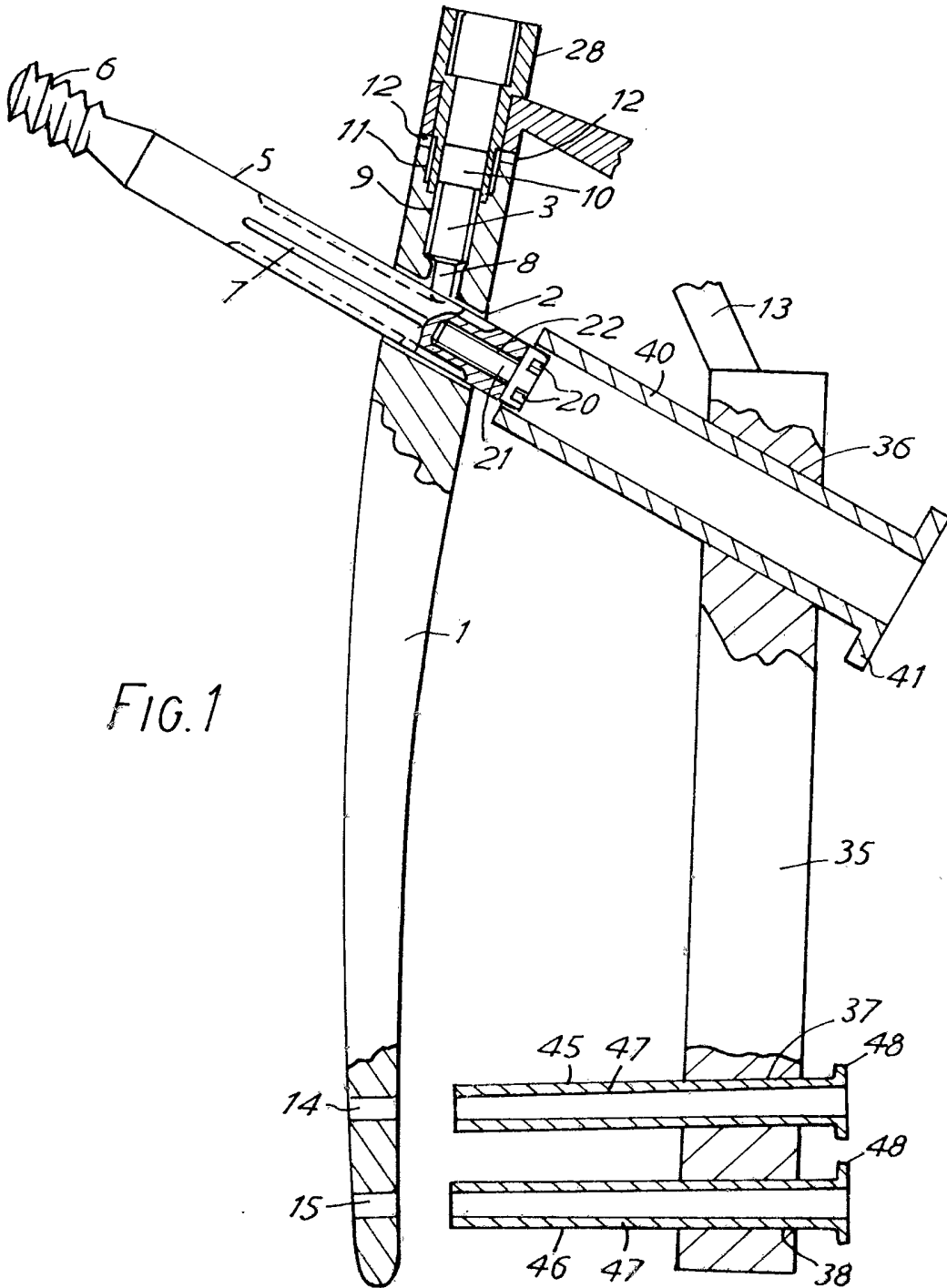



26834/88

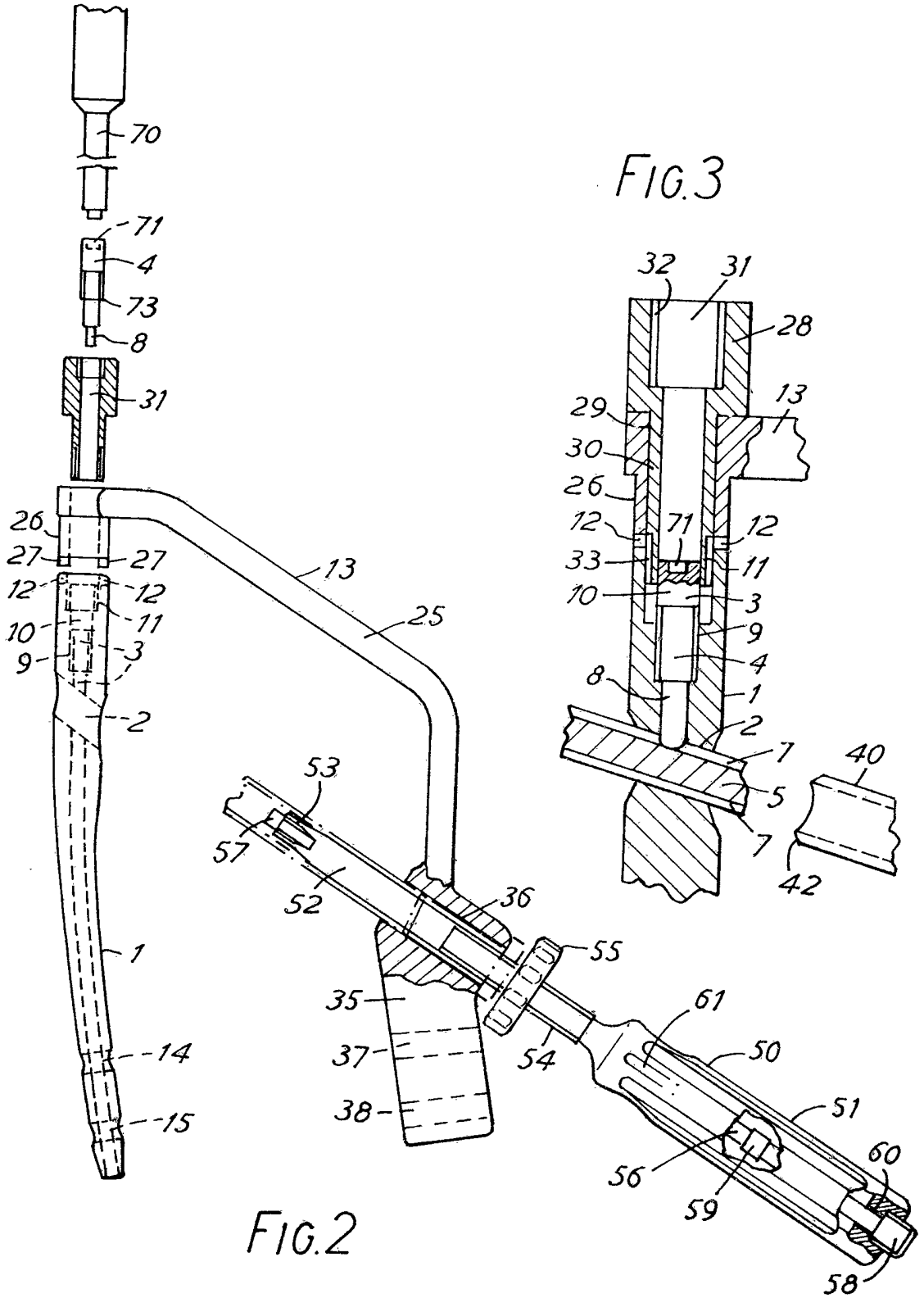

FIG. 3

FIG. 2

12  
11  
10  
9  
8  
7  
6  
5  
4  
3  
2  
1

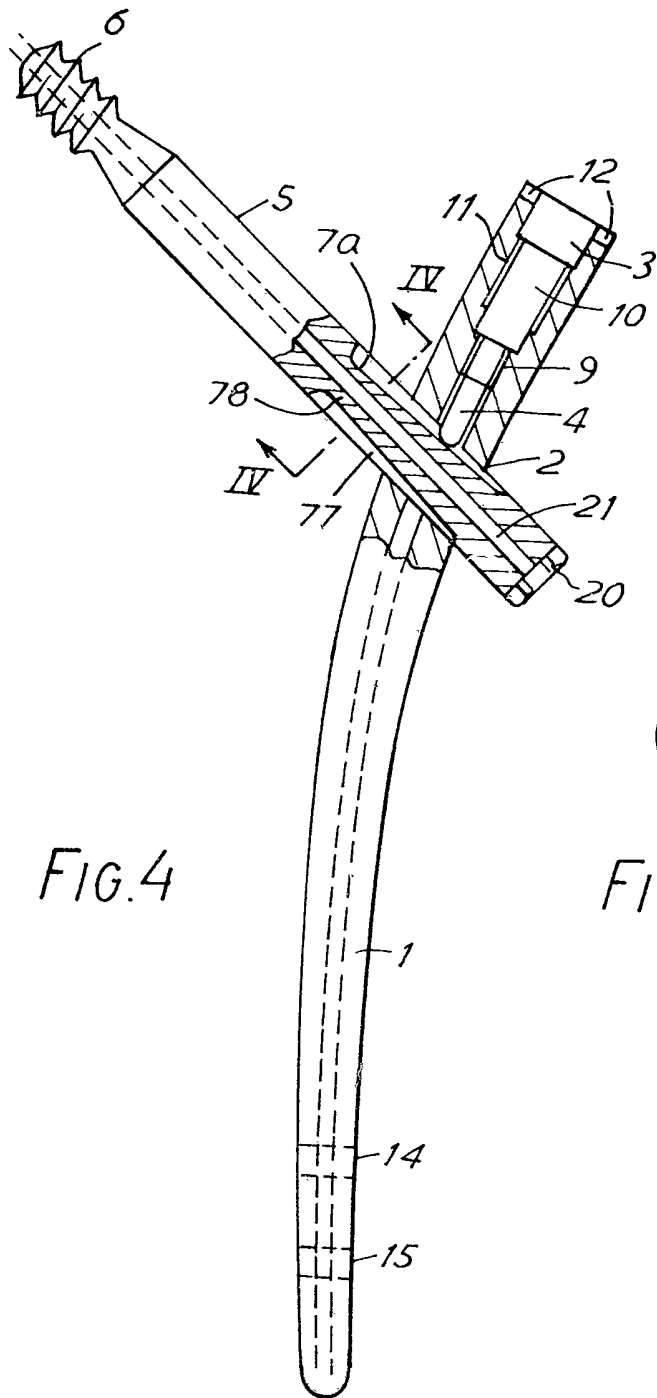

FIG. 4

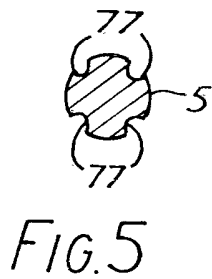

FIG. 5

12  
11  
10  
9  
8  
7  
6  
5  
4  
3  
2  
1