



US 20080084104A1

(19) **United States**

(12) **Patent Application Publication**
VanHorn

(10) **Pub. No.: US 2008/0084104 A1**

(43) **Pub. Date: Apr. 10, 2008**

(54) **PORTABLE KNOCK-DOWN LATERALLY
EXTENSIBLE BENCH SEAT**

Publication Classification

(76) Inventor: **Patrick VanHorn**, Mahanoy City,
PA (US)

(51) **Int. Cl.**
A47C 7/02 (2006.01)
(52) **U.S. Cl.** **297/452.4**

(57) **ABSTRACT**

Correspondence Address:
Donald W. Meeker
Patent Agent
924 East Ocean Front #E
Newport Beach, CA 92661

A portable knock-down seat which telescopically extends laterally to become a bench for use by sportsmen, as a shower chair, as a patient transfer bench, or as a stool. The portable seat comprises a laterally extendable telescopic bottom, a detachable and laterally extendable telescopic back, two detachable and vertically adjustable telescoping leg assemblies, and detachable armrests. The portable seat may be transported in a carrying bag or backpack, or by using straps.

(21) Appl. No.: **11/545,643**

(22) Filed: **Oct. 10, 2006**

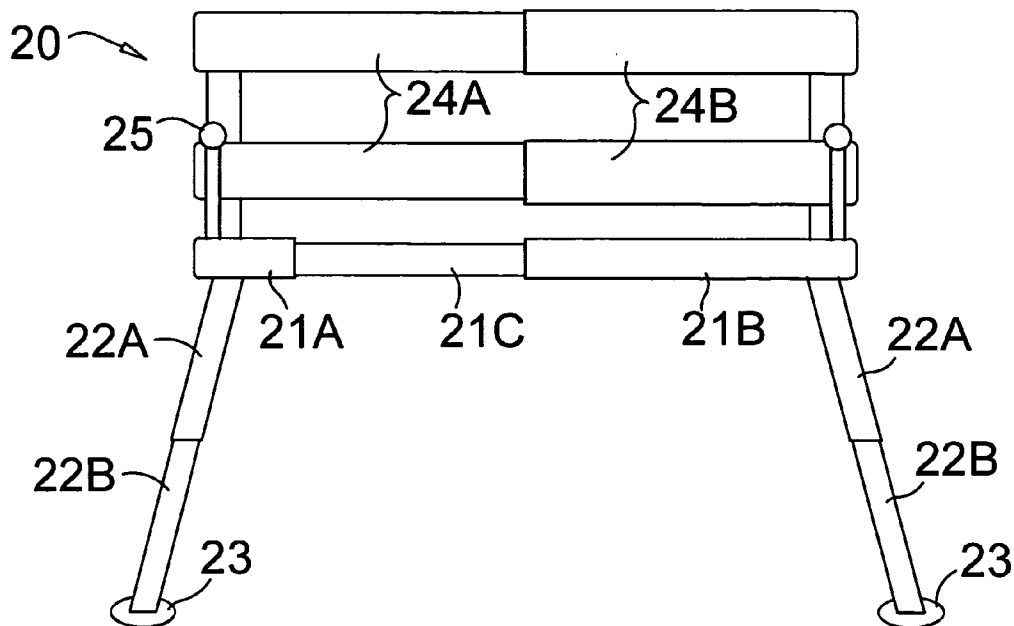

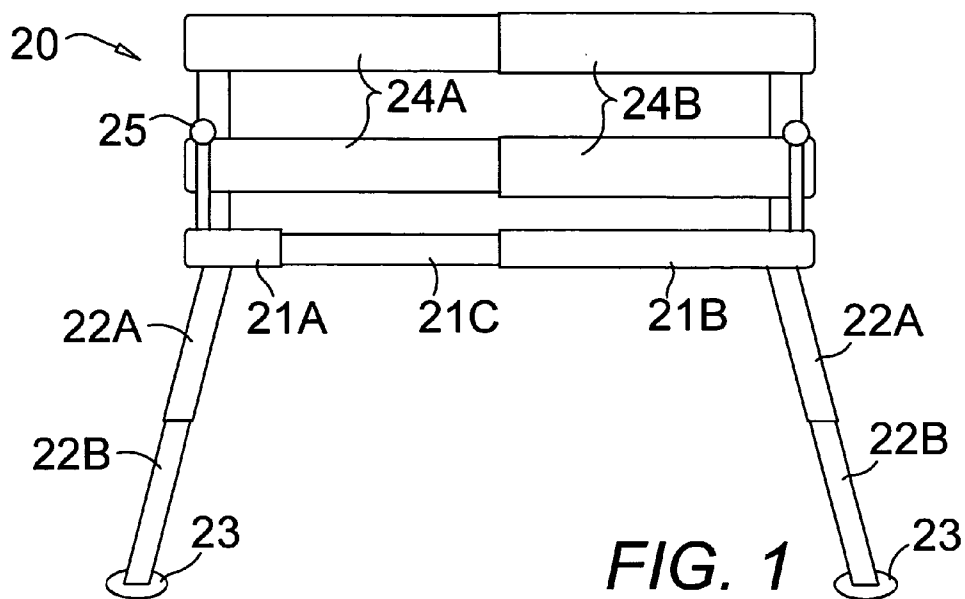

FIG. 1

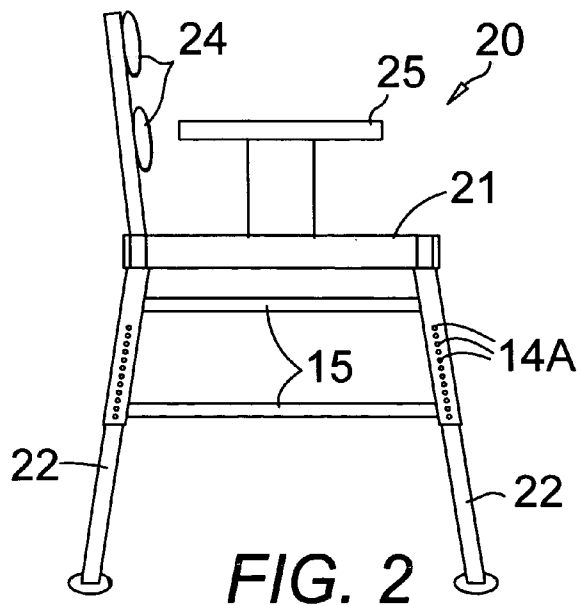
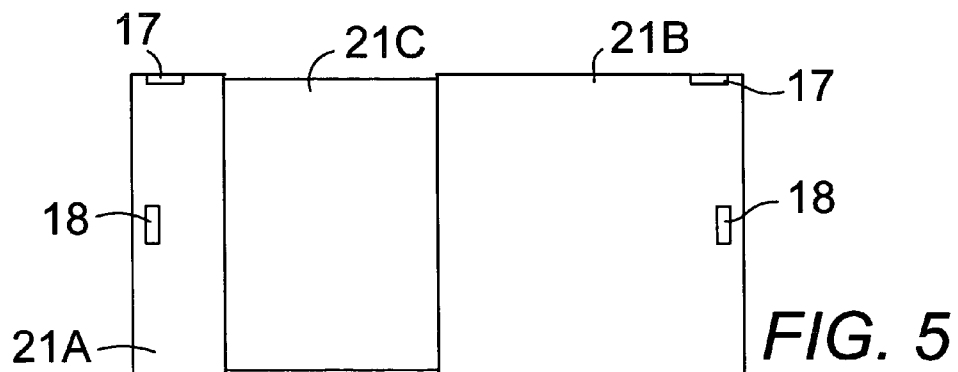
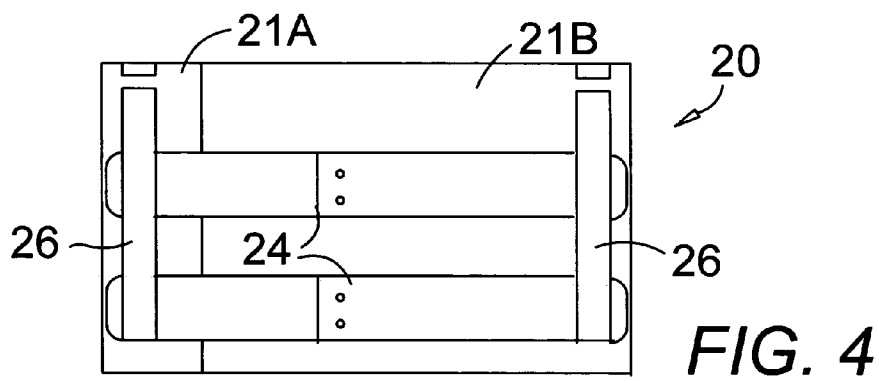
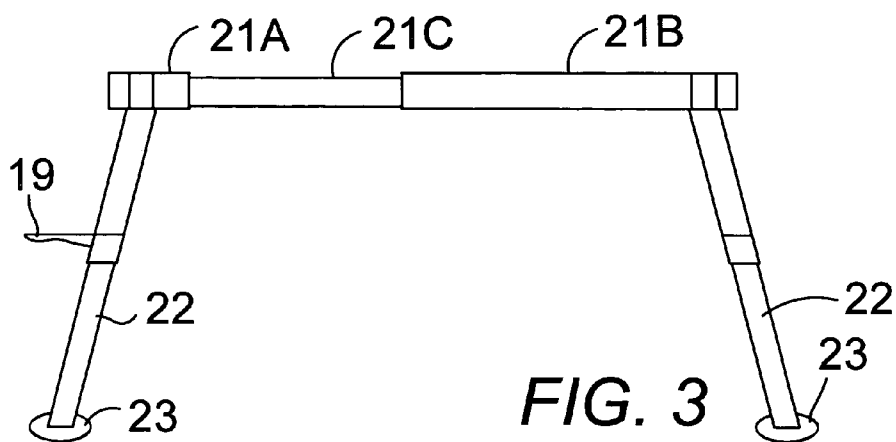
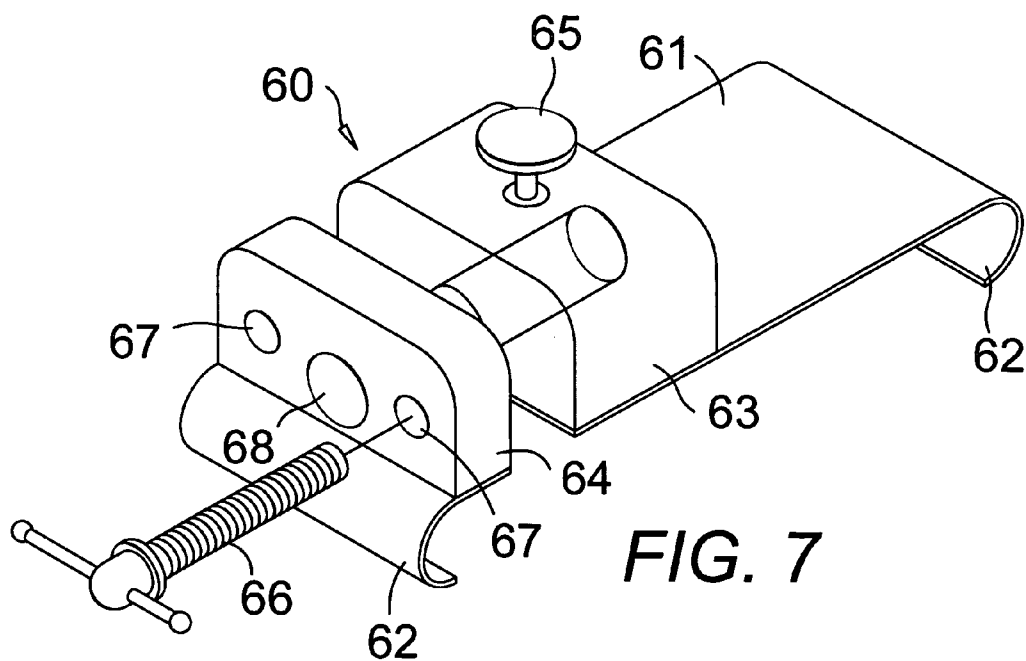
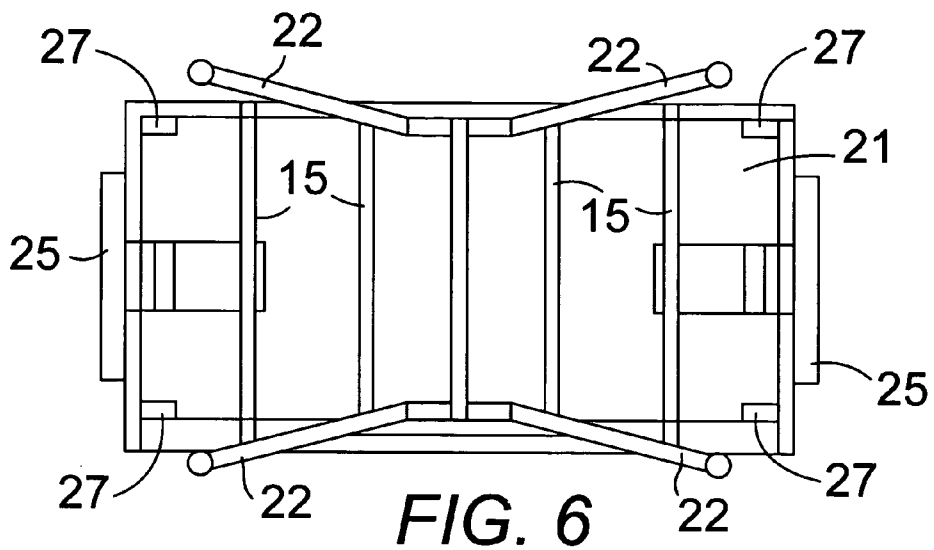

FIG. 2





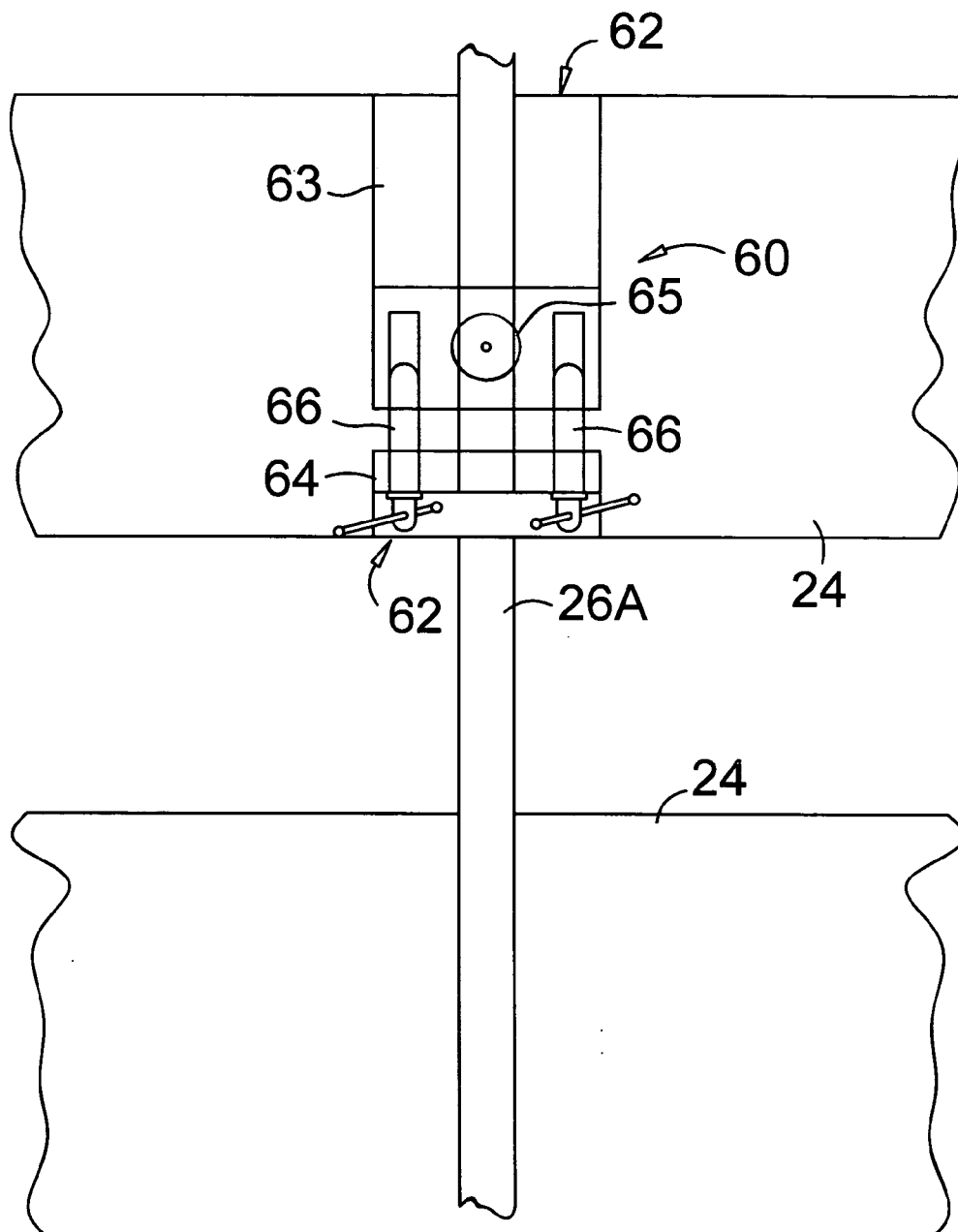
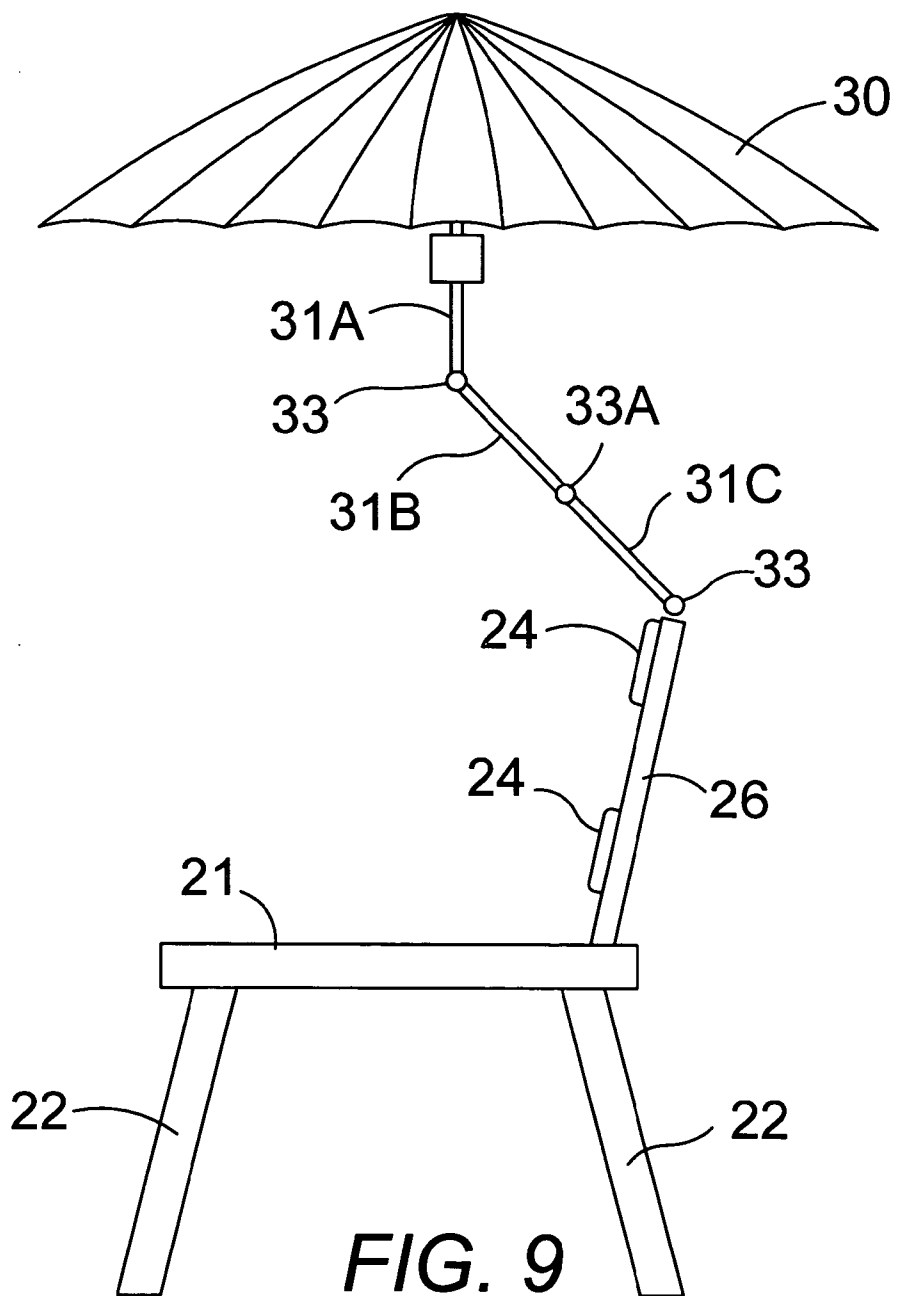
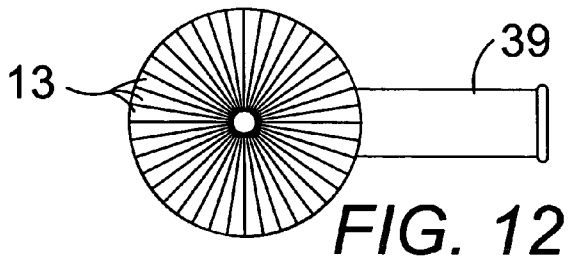
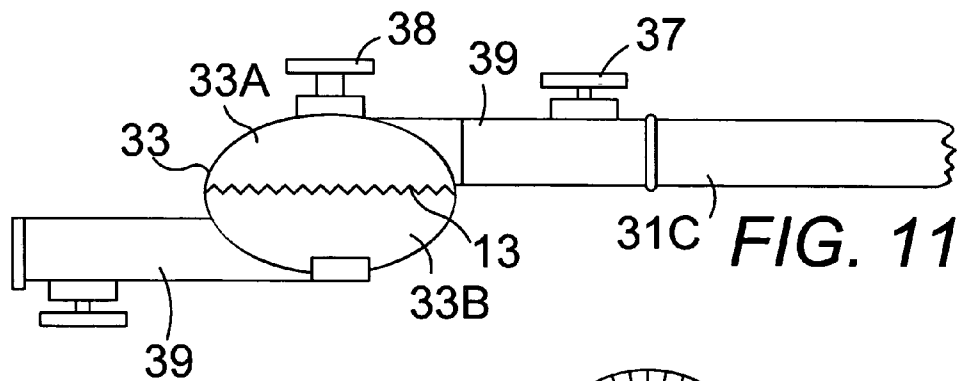
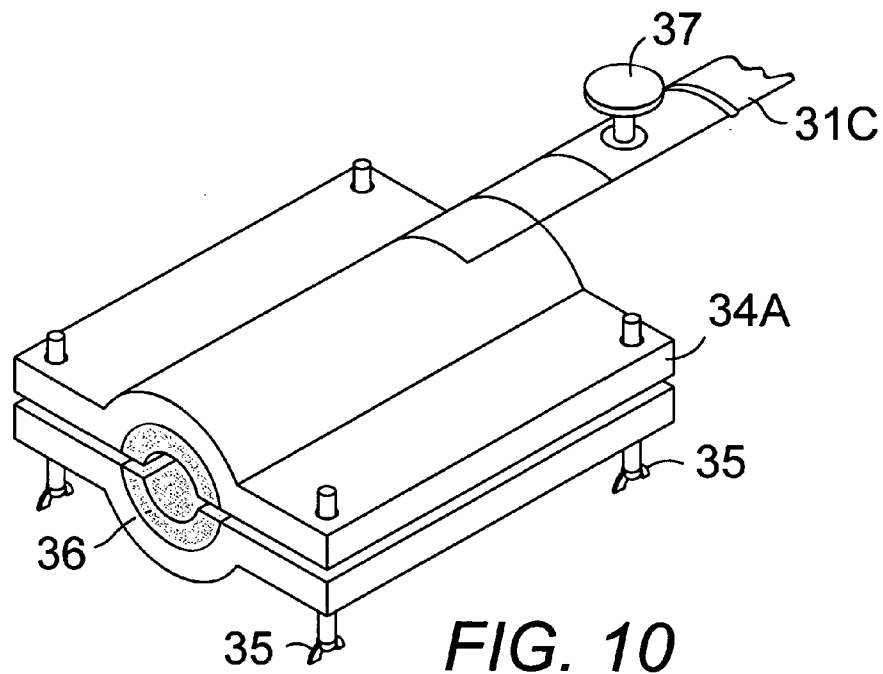
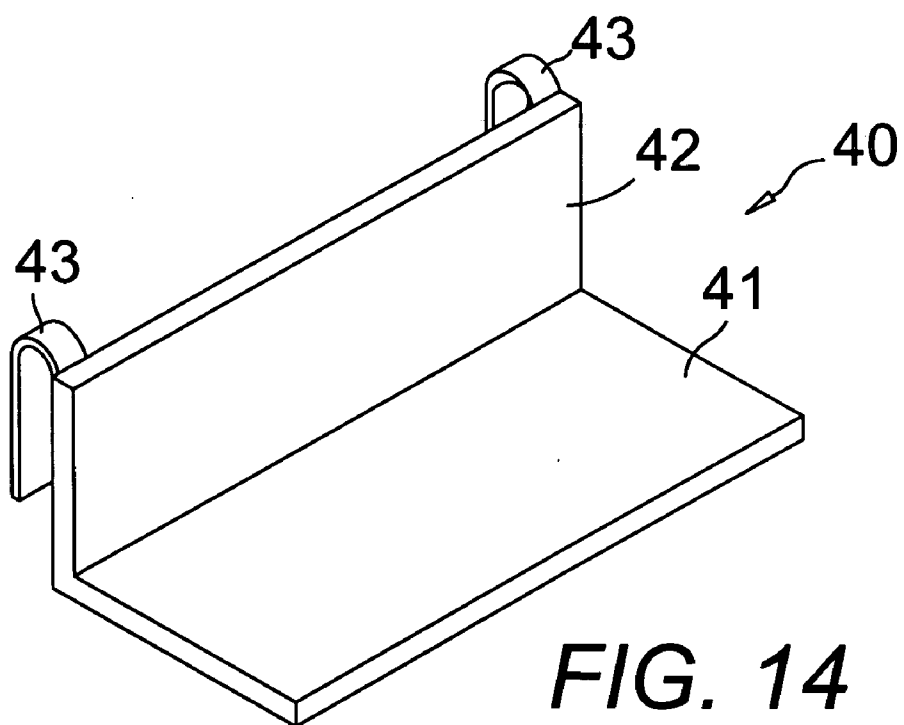
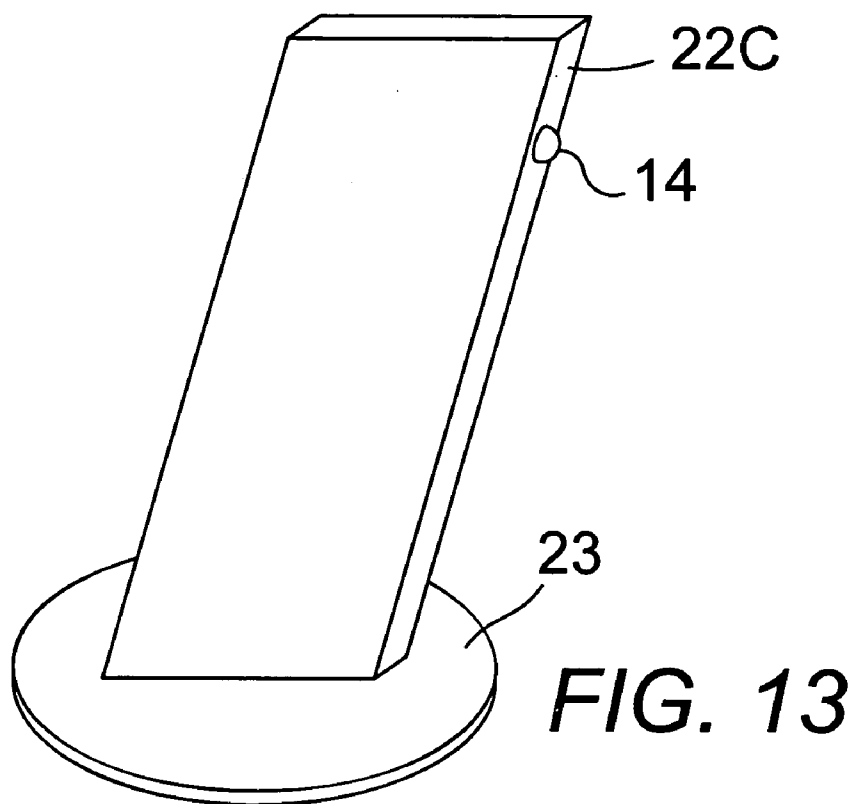

FIG. 8







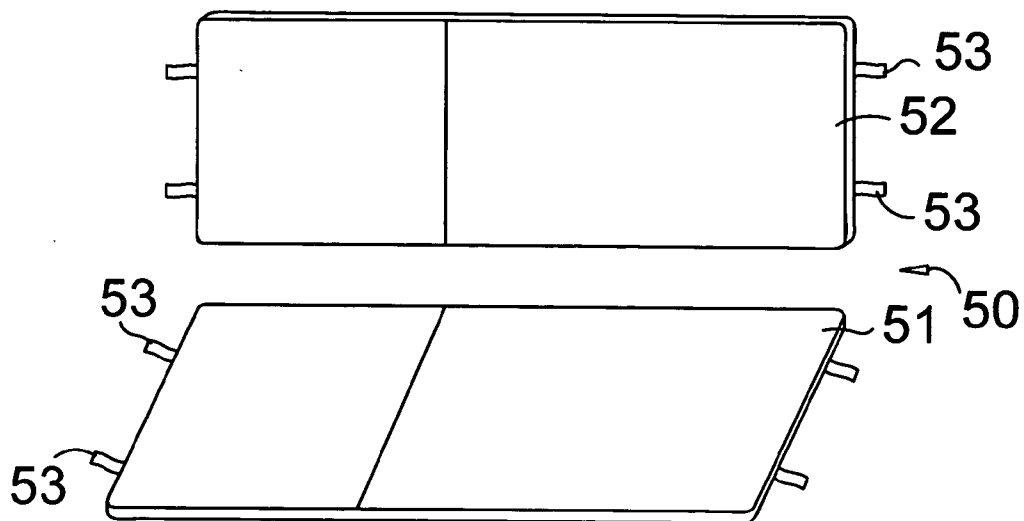

FIG. 15

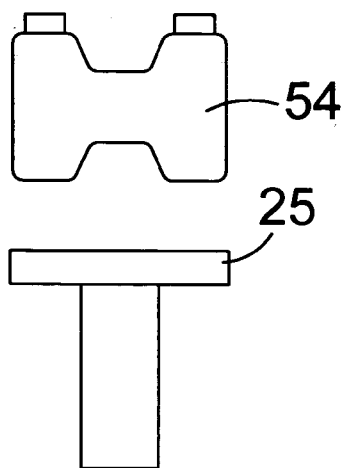

FIG. 16

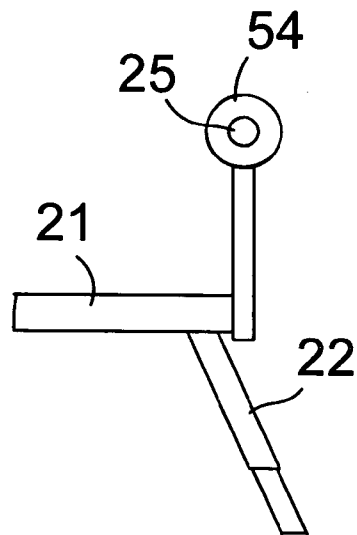

FIG. 17

**PORTABLE KNOCK-DOWN Laterally
EXTENSIBLE BENCH SEAT**

**CROSS-REFERENCE TO RELATED
APPLICATIONS**

[0001] Not Applicable.

**STATEMENT REGARDING FEDERALLY
SPONSORED RESEARCH OR DEVELOPMENT**

[0002] Not Applicable.

**THE NAMES OF THE PARTIES TO A JOINT
RESEARCH OR DEVELOPMENT**

[0003] Not Applicable.

BACKGROUND OF THE INVENTION

[0004] 1. Field of the Invention

[0005] The present invention relates to laterally extendable seats and particularly to a portable knock-down seat which telescopically extends to become a bench or wide seat for use by sportsmen, as a shower chair, as a patient transfer bench, or as a stool; the portable seat comprises a laterally extendable telescopic bottom, a detachable and laterally extendable telescopic back, two detachable and vertically adjustable telescoping leg assemblies, detachable armrests, and a means for carrying the portable seat.

[0006] 2. Description of Related Art Including Information Disclosed Under 37 CFR 1.97 and 1.98

[0007] Portable folding seating is well known and outdoor pieces are often referred to as "lawn furniture". For example, folding chairs have previously been provided which include metal tubing frames that can be folded with respect to each other and with the seat folded therebetween. Such chairs tend to have the advantages of being relatively lightweight, easy to transport and inexpensive. However, a disadvantage relates to their lack of adaptability to sloping and uneven support surfaces. Such surfaces are often encountered outdoors, while fishing or hunting. Many portable chairs with telescopically adjustable legs have been proposed to compensate for such uneven terrain.

[0008] Often there is a need to set down equipment or food or other items being carried as well as to sit down outdoors or there may be more than one person, such as at an outdoor event. The prior art does not adequately address these needs one portable seat.

[0009] Prior art U.S. Patent Application #20040189062, published Sep. 30, 2004 by Knight, provides an all terrain bench pack which is carried by one person the same way you carry a backpack. The unit has quick release hardware, padded compartments, and indestructible and water proof material and zippers with scent-lock system. The frame converts to a very comfortable and sturdy bench (seat) without disconnecting anything. Each of the four legs adjusts individually to different lengths to assure a comfortable and level seat regardless of terrain. Extra large feet keeps everything stable in uneven rocky or soft ground. The bench (seat) sports a back for extra comfort while sitting long periods.

[0010] Prior art U.S. Pat. No. 6,039,403, issued Mar. 21, 2000 to Hargroder, is for a shower/bathtub transfer chair that is capable of disassembly into five basic components. The chair seat and back structures, separable from each other and from the support frame for the device, serve as two of the

five components. The remaining three components include an inside leg frame component, an outside leg frame component, and a cross frame component. When disassembled through the use of locking pin mechanisms, each of the five components described provide a generally planar geometry that can be stacked and arranged within a rectangular, suitcase-styled enclosure, for transport and/or storage.

[0011] Prior art U.S. Pat. No. 966,891, issued Aug. 9, 1910 to Dudley, claims a laterally extensible seat which may be adjusted to change the seating capacity thereof. The seat comprises a plurality of telescoping parts, which when in collapsed condition constitute a single seat and when extended form an enlarged seat for the accommodation of two or more persons. The seat is portable and the extensible seat, extensible back and leg portions may be folded to be stored in limited space

[0012] Prior art U.S. Pat. No. 371,091, issued Oct. 4, 1887 to Miller, describes an extensible seat, such as a church pew, wherein the back portion and bottom seat portion have laterally extendable telescoping end sections. The telescoping sections are formed from slats in the back or seat and the end section which are positioned alternately and relative to each other to allow lateral movement of the end sections. The Miller device is not portable.

[0013] Prior art U.S. Pat. No. 5,660,436, issued Aug. 26, 1997 to Wilson, discloses a laterally extendable furniture device that includes a primary support section and a supplemental support section slidably connected to the primary support section for movement between a retracted position and an expanded position. At the retracted position the supplemental support section is stored within the primary support section, and at the expanded position the supplemental support section extends laterally from the primary support section to provide an expanded support surface. The laterally extendable furniture design can readily be adapted to a variety of furniture pieces including chairs, tables, desks and shelves. The furniture device is manufactured from molded plastic components, making it easy and economical to manufacture and durable.

[0014] Prior art U.S. Pat. No. 6,135,545, issued Oct. 24, 2000 to Liao, indicates a multifunctional furniture assembly including four furniture units that can be assembled to form a bed, a table, or a chair. First and second furniture units are mounted juxtaposed to other yet allowing sliding movement relative to each other. Third and fourth furniture units are mounted juxtaposed to each other and behind the first and second furniture units, respectively. The third and fourth furniture units are also slidable relative to each other. The third and fourth furniture units may be pivoted relative to the first and second furniture units and then positioned to form a length-adjustable chair.

[0015] Prior art U.S. Pat. No. 6,095,607, issued Aug. 1, 2000 to Wenzel, provides a universal adjustable-leg chair having four telescoping legs with provision for setting each leg at a desired length. The chair adjusts to very uneven terrain so that the user can sit in a generally level and comfortable position especially for fishing on the bank of a river or lake, uneven camp sites, graded spectator seating locations, etc. The folding aluminum chair has horizontal connecting braces extending across front and back at the bottom ends of upper leg sections which comprise tubes of the telescoping connection. When the lower extensions of the telescoping legs are fully removed, the chair serves as a

beach chair with the connecting braces being the primary contacts with the sand or ground.

[0016] Prior art U.S. Pat. No. 6,056,353, issued May 2, 2000 to Meara, claims a lightweight, portable, adjustable folding chair accommodated specifically for persons with a joint disability which causes sitting or rising from a seated position to be difficult including partial or total hip replacement patients. The chair has adjustable height legs, solid cushioned seat and solid arm rests. The feet of the chair are covered with replaceable rubber tips for safety. The chair may be folded for transport and storage. A handle within the backrest is included for ease of carrying.

[0017] Prior art U.S. Pat. No. 3,765,718, issued Oct. 16, 1973 to Chen, illustrates a folding chair having four separately adjustable, extendable telescoping legs which are pivotally connected to the bottom of the seat. The legs may be retracted and folded underneath the seat when not in use.

[0018] What is needed is a portable knock-down seat which telescopically extends to become a bench or wide seat for use by sportsmen, as a shower chair, as a patient transfer bench, as a seat for one or two at an outdoor event, as a stool, or for other situations requiring a portable expandable bench the portable seat comprises a laterally extendable telescopic bottom, a detachable and laterally extendable telescopic back, two detachable and vertically adjustable telescoping leg assemblies, detachable armrests, and a means for carrying the portable seat.

BRIEF SUMMARY OF THE INVENTION

[0019] An object of the present invention is to provide a portable knock-down seat comprising a laterally extendable telescopic bottom, a detachable and laterally extendable telescopic back, two detachable and vertically adjustable telescoping leg assemblies, detachable armrests, and a means for carrying the portable seat which telescopically extends to become a bench or wide seat for use by sportsmen, as a shower chair, as a patient transfer bench, as a seat for one or two at an outdoor event, as a stool, or for other situations requiring a portable expandable bench.

[0020] Another object of the present invention is to provide a carrying bag having a handle for transporting the portable knock-down seat.

[0021] An additional object of the present invention is to provide a backpack type harness or straps for transporting the portable knock-down seat.

[0022] One more object of the present invention is to provide accessories for the portable knock-down seat which include an umbrella clamp, a utility tray, a step, replaceable short legs, and padding on the seat bottom, seat top, and armrests.

[0023] A further object of the present invention is to provide padding on the seat bottom, seat top, and armrests which is a waterproof or water resistant material such as neoprene or rubber with mating hook and loop fastener strips to attach and interconnect the cushions.

[0024] In brief, an expansible portable bench seat comprises a laterally extensible telescoping seat bottom, a laterally extensible seat back removably attachable to the seat bottom, at least two detachable telescoping leg assemblies removably attachable to the seat bottom, a pair of detachable armrests each attachable to the seat bottom at opposite ends of the seat bottom; and a means for carrying the portable expansible bench seat with the seat bottom, the seat back, the

leg assemblies and the armrests disconnected from each other and positioned in parallel alignment for transporting and storing.

[0025] The expansible portable bench seat telescopically extends to become a bench or wide seat for use by sportsmen, as a shower chair, as a patient transfer bench, as a seat for one or two at an outdoor event, as a stool, or for other situations requiring a portable expandable bench and may be used for hunting, fishing, camping, outdoor events, RV, home use, institutional use, industrial or wherever an extensible bench seat would be useful. The bench seat adjusts telescopically between 26 inches and 40 inches wide. The present invention is assembled and disassembled for transport/storage using a spring loaded pin and hole connection between members. A number of spaced holes along a first member are used with a spring loaded pin a second member sliding into the first member allows adjustment of the length of the joined member. The regular legs provided are adjustable in height for a range of seat heights from 14 inches to 22 inches above the ground. The legs adjust to uneven ground or to desired sitting or working height. The legs just slide into the mating openings in the seat and lock in place. An attachable foot step may be affixed to the leg assembly.

[0026] Accessories for the present invention include an umbrella, an umbrella clamp, a utility tray, a step, detachable short legs, and padding on the seat bottom, seat top, and armrests. The umbrella could be any color or print, such as a camouflage print to be used in hunting, for example. The utility tray or shelf can hold tools paint cans, screws, and etc. for working or equipment for hunting or food and beverages.

[0027] The present invention can be used by one person with room for equipment or two people. The portable knock-down seat may be used for painting, dry wall, wall-papering, general contract work, or as a handy man helper stool. The present invention may be used with or without the back rest and arm rest. Without the backrest and armrests it may be used as a stool or as an aid for smaller or older pets to access higher places of rest.

[0028] The seat and back rest pads and arm pads are preferably made of a waterproof or water resistant material such as neoprene or rubber with Velcro strips to attach and interconnect the cushions. The pads may be made from water resistant material in varying prints or colors, such as a camouflage print for use in hunting, for example.

[0029] The extensible bench, back and arms are made of strong light weight aluminum rectangular tubing, round tubing, plates, channels or other structural shapes which can be aluminum color or sprayed a color, such as a drab green or brown for hunting or nautical colors for beach use, for example.

[0030] The present invention can be broken down and transported easily. When broken down, the portable knock-down seat may be transported within a carrying bag or by using a backpack-type harness or straps.

[0031] An advantage of the present invention is that the seat and back are laterally adjustable.

[0032] Another advantage of the present invention is that the padding is water resistant.

[0033] One more advantage of the present invention is that the height of the legs is adjustable.

[0034] An additional advantage of the present invention is that it is collapsible and portable.

[0035] A further advantage of the present invention is that it will not sink into soft ground.

[0036] A contributory advantage of the present invention is that it has a wide array of applications.

BRIEF DESCRIPTION OF THE SEVERAL VIEWS OF THE DRAWINGS

[0037] These and other details of my invention will be described in connection with the accompanying drawings, which are furnished only by way of illustration and not in limitation of the invention, and in which drawings:

[0038] FIG. 1 is a front elevational view of the expansible portable bench seat of the present invention with all of the components assembled for use;

[0039] FIG. 2 is a side elevational view of the expansible portable bench seat of FIG. 1;

[0040] FIG. 3 is a front elevational view of the expansible portable bench seat without a seat back and armrests;

[0041] FIG. 4 is a top plan view of the seat bottom of the expansible portable bench seat of FIG. 1 with the seat bottom telescoped down to its smallest length and the seat back stacked on top of the seat bottom;

[0042] FIG. 5 is a top plan view of the seat bottom of the expansible portable bench seat of FIG. 1 with the seat bottom telescoped out to its longest length with no seat back and armrests shown;

[0043] FIG. 6 is a bottom plan view of the seat bottom of the expansible portable bench seat of FIG. 1 with the seat bottom telescoped down to its smallest length and the leg assemblies stacked on the bottom of the seat bottom for transportation and storage;

[0044] FIG. 7 is an enlarged perspective view of the umbrella clamp of the expansible portable beach seat of FIG. 1;

[0045] FIG. 8 is an enlarged rear elevational view of a portion of the seat back of the expansible portable beach seat of FIG. 1 with the umbrella clamp attached to the back of the seat back;

[0046] FIG. 9 is a side elevational view of the expansible portable bench seat of FIG. 1 showing an attached umbrella;

[0047] FIG. 10 is an enlarged perspective view of the umbrella clamp of the expansible portable bench seat of FIG. 1;

[0048] FIG. 11 is an enlarged elevational view of the adjustable elbow and adjacent rods of the umbrella support of the expansible portable bench seat of FIG. 1;

[0049] FIG. 12 is an enlarged plan view of one side of the adjustable elbow and one of the adjacent rods of the umbrella support of FIG. 11;

[0050] FIG. 13 is an enlarged perspective view of one of the alternative short legs of the expansible portable bench seat of FIG. 1, showing the rubberized pad at the bottom and a spring-loaded locking pin near the top;

[0051] FIG. 14 is a perspective view of the utility tray for the expansible portable bench seat of FIG. 1;

[0052] FIG. 15 is a perspective view of an attachable seat bottom pad and seat back pad for the expansible portable bench seat of FIG. 1;

[0053] FIG. 16 is a perspective view of an attachable armrest pad aligned for installing on an armrest of the expansible portable bench seat of FIG. 1;

[0054] FIG. 17 is a partial front elevational view showing one end of the expansible portable bench seat of FIG. 1, with the armrest pad installed on the armrest.

DETAILED DESCRIPTION OF THE INVENTION

[0055] In FIGS. 1-17, an expansible portable bench seat 20 comprises a telescoping seat bottom 21, a telescoping seat back 24A and 24B, telescoping leg assemblies 22, and removable armrests 25. The seat bottom 21, the seat back 24A and 24B, and the leg assemblies 22 are removably interconnectable to form an expansible portable bench seat 20.

[0056] The expansible portable bench seat 20 comprises a laterally extensible seat bottom 21. The seat bottom 21 comprises three seating platforms 21A, 21B, and 21C telescopically interconnected to alter the width of the seat bottom 21. The three substantially horizontal aligned bottom seating platforms 21A, 21B, and 21C comprise two outer seating platforms 21A and 21B each having an outer end portion forming an end of the bench seat 21 and one or more middle seating platforms 21C intermediate the outer seating platforms 21A and 21B. The ends of the bench seat 21A and 21B have a means for receiving 17 the upright support sections of the seat back 26 and a means for receiving 18 the armrests 25, as shown in FIG. 5, and a means for receiving 27 the upper portion of the leg assemblies 22A or 22C, as indicated in FIG. 6. The middle seating platform 21C is telescopically interconnected to the two outer seating platforms 21A and 21B to alter the width of the seat bottom 21.

[0057] The expansible portable bench seat 20 also comprises a laterally extensible seat back 24A and 24B removably attachable to the seat bottom 21. The means for removably attaching the seat back 24A and 24B to the seat bottom 21, as shown in FIG. 2, is to removably insert the bottom end of the vertical supports 26 into mating openings 17 in the seat bottom 21, shown in FIG. 5. The laterally extensible seat back 24A and 24B comprises two back rest portions 24A and 24B telescopically interconnected to alter the width of the seat back 24A and 24B and a means for removably attaching the seat back 24A and 24B to the seat bottom 21. The seat back comprises two or more substantially horizontal back support elongated elements 24A and 24B in substantially vertical spaced alignment, each of the two back support elongated elements 24A and 24B having two back rest portions 24A and 24B telescopically interconnected to alter the width of the seat back 24A and 24B, and two substantially vertical supports 26 interconnecting the horizontal back support elongated elements 24A and 24B, one vertical support 26 at each end of the seat bottom 21, as shown in FIG. 1.

[0058] The present invention 20 further comprises two detachable telescoping leg assemblies 22 removably attachable to the seat bottom 21. The leg assemblies 22 each comprise two substantially vertical leg sections 22A and 22B telescopically interconnected to alter the height of the leg assembly 22 and therefore alter the height of the seat bottom 21, and a means for removably attaching each of the telescoping leg assemblies 22 to the seat bottom 21, as shown in FIGS. 1-3, comprises removably inserting an upper end of an upper leg section 22A into a corresponding leg opening 27 in the seat bottom 21, shown in FIG. 6. The two detachable telescoping

leg assemblies 22 are removably attachable to the seat bottom 21, one at each end 21A and 21B of the seat bottom 21. The leg assemblies 22 each comprise a substantially vertical upper leg section 22A comprising two vertical upper supports 22A interconnected by one or more horizontal brace members 15, one of the upper supports 22A attached to a front of a side edge of the seat bottom 21 and the other of the upper supports 22A attached to a back of the side edge of the seat bottom 21. The leg assemblies 22 also comprise a pair of substantially vertical lower leg sections 22B each telescopically interconnected to an upper support member 22A to alter the height of the leg assembly 22 and therefore alter the height of the seat bottom 21. The leg assemblies 22 further comprise a means for removably locking the lower support member 22B to the upper support member 22A at any of a variety of heights of the leg assembly 22. The means for removably locking the lower support member 22B to the upper support member 22A comprises a spring loaded pin 14 in one member 22A alternately engaged in one of a series of spaced holes 14A connection between members 22A and 22B, as shown in FIG. 2.

[0059] The device 20 also comprises a pair of detachable armrests 25 each attachable to the seat bottom 21 at opposite ends of the seat bottom 21 and a means for removably attaching each of the armrests 25 to the seat bottom 21. The means for removably attaching each of the armrests 25 to the seat bottom 21, as in FIGS. 1 and 2, comprises removably inserting a bottom end of an armrest 25 in a mating opening 18 in the seat bottom 21, shown in FIG. 5.

[0060] The expansible portable bench seat 20 further comprises a means for carrying the bench seat 20 with the seat bottom 21, the seat back 24A and 24B, the leg assemblies 22 and the armrests 25 disconnected from each other and positioned in parallel alignment for transporting and storing, as shown in FIGS. 4 and 6. The means for carrying the portable expansible bench seat 20 comprises a carrying bag with a handle. Alternately, a backpack-type harness or carrying straps may be provided to carry the device 20.

[0061] The expansible portable bench 20 further comprises a series of pads 50 including a seat rest pad 51, shown in FIG. 15, attached to the seat bottom 21; a seat rest pad 52, also shown in FIG. 15, removably attached to the seat back 24A, 24B and 26; and an arm rest pad 54, shown in FIGS. 16 and 17, removably attached to each of the arm rests 25. The pads 51, 52 and 54 are made from a waterproof or water resistant material such as neoprene or rubber. Mating hook and loop fastener strips are used to removably attach and interconnect the pads 51, 52 and 54 to the device 20.

[0062] In FIGS. 7-12, the expansible portable bench 20 may also comprise an umbrella clamp 60 removably attachable to the seat back 24A and 24B at any of a variety of different locations along the length of the seat back 24A and 24B. The umbrella clamp 60 comprises a clamp 63 and 64 for attachment to the seat back 24A and 24B and an umbrella support comprising a series of rods 31A, 31B and 31C interconnected together by pivot joints 33A and adjustable elbows 33 to allow for multiple angles, heights and positions of an umbrella 30 attached thereto.

[0063] The expansible portable bench seat 20 may alternately comprise four short legs 22C, shown in FIG. 13, with rubber pads 23 on a bottom end of the short legs 22C to prevent sinking on soft ground. The short legs 22C may be

removably attached to the seat bottom 21 in place of the leg assemblies 22 for use in outdoor activities such as low to the ground hunting, for example.

[0064] The expansible portable bench seat 20 may also comprise a utility tray 40, shown in FIG. 14, removably attached to the top of the seat back 24A and 24B by a pair of hooks 43 hooked over the seat back 24A and 24B so that the utility tray 40 hangs down behind the seat back 24A and 24B for storing items on the utility tray bottom 41 thereof.

[0065] The expansible portable bench seat 20 may further comprise a foot step 19, shown in FIG. 3, removably attachable to the leg assembly 22 so that a user may step on the foot step 19 for reaching higher. Alternately, the foot step 19 may be used as a foot rest while sitting on the bench 20.

[0066] In use, the bench seat 21 and back 24A and 24B adjust telescopically between 26 inches and 40 inches wide, for a variety of applications. The expansible portable bench seat 20 may be employed by sportsmen, as a shower chair, as a patient transfer bench, as a seat for one or two at an outdoor event, as a stool, or for other situations requiring a portable expandable bench. The expansible portable bench seat 20 may be used for hunting, fishing, camping, outdoor events, RV, home use, institutional use, industrial or wherever an extensible bench seat 20 would be useful. Alternately, with the seat back 24A and 24B and armrests 25 removed from the seat bottom 21, as shown in FIG. 3, the device 20 may be used as a stool or as an aid to assist smaller or older pets to access higher places of rest.

[0067] The leg assemblies 22 provided are adjustable in height for a range of seat 21 heights from 14 inches to 22 inches above the ground. A number of spaced holes 14A, shown in FIG. 2, along a first member 22A are used with a spring loaded pin 14 on a second member 22B, with the second member 22B sliding into the first member 22A, which allows adjustment of the length of the joined leg assembly member 22. The leg assemblies 22 may be adjusted to uneven ground or to a desired sitting or working height.

[0068] The present invention 20 is disassembled for transport/storage by removing the armrests 25 from the armrest openings 18 in the seat 21, removing the seat back vertical supports 26 from the seat back openings 17 in the seat 21, and removing the leg assemblies 22 from the corresponding leg openings 27 in the seat 21. The seat bench 20 is then readied for transport by collapsing the telescoping portions 21A, 21B, and 21C of the seat bottom 21 down to its smallest length, telescoping the seat back portions 24A and 24B to their smallest combined length, and stacking the seat back 24 on top of the seat bottom 21, as shown in FIG. 4. The seat back 24 and the seat bottom 21 are then stacked of top of the leg assemblies 22, and the armrests 25 inserted between the leg assemblies 22 and the seat bottom 21 for transportation and storage, as shown in FIG. 6. The disassembled bench seat 20 may be transported in a carrying bag with a handle, a backpack-type harness, or carrying straps.

[0069] It is understood that the preceding description is given merely by way of illustration and not in limitation of the invention and that various modifications may be made thereto without departing from the spirit of the invention as claimed.

What is claimed is:

1. An expansible portable bench seat comprising:

a laterally extensible seat bottom comprising at least two seating platforms telescopically interconnected to alter the width of the seat bottom;

a laterally extensible seat back removably attachable to the seat bottom, the laterally extensible seat back comprising at least two back rest portions telescopically interconnected to alter the width of the seat back and a means for removably attaching the seat back to the seat bottom;

at least two detachable telescoping leg assemblies removably attachable to the seat bottom, the leg assemblies each comprising at least two substantially vertical leg sections telescopically interconnected to alter the height of the leg assembly and therefore alter the height of the seat bottom, the seat bottom and the seat back and the leg assemblies removably interconnectable to form an expansible portable bench seat, and a means for removably attaching each of the telescoping leg assemblies to the seat bottom;

a pair of detachable armrests each attachable to the seat bottom at opposite ends of the seat bottom and a means for removably attaching each of the armrests to the seat bottom;

a means for carrying the portable expansible bench seat with the seat bottom, the seat back, the leg assemblies and the armrests disconnected from each other and positioned in parallel alignment for transporting and storing.

2. The expansible portable bench seat of claim 1 wherein the seat bottom comprises three substantially horizontal aligned bottom seating platforms comprising two outer seating platforms each having an outer end portion forming an end of the bench seat, the ends of the bench seat having a means for receiving the seat back, a means for receiving the leg assemblies and a means for receiving the armrests, and at least one middle seating platform intermediate the outer seating platforms, the middle seating platform telescopically interconnected to at least one of the two outer seating platforms to alter the width of the seat bottom.

3. The expansible portable bench seat of claim 1 wherein the seat back comprises at least two substantially horizontal back support elongated elements in substantially vertical spaced alignment, each of the at least two back support elongated elements having at least two back rest portions telescopically interconnected to alter the width of the seat back, and at least two substantially vertical supports interconnecting the horizontal back support elongated elements, one vertical support at each end of the seat bottom, wherein a bottom end of the vertical support removably inserted in a mating opening in the seat bottom.

4. The expansible portable bench seat of claim 1 comprising two detachable telescoping leg assemblies removably attachable to the seat bottom, one at each end of the seat bottom, the leg assemblies each comprising a substantially vertical upper leg section comprising two vertical upper supports interconnected by at least one horizontal brace member, one of the upper supports attached to a front of a side edge of the seat bottom and the other of the upper supports attached to a back of the side edge of the seat bottom and a pair of substantially vertical lower leg sections each telescopically interconnected to an upper support member to alter the height of the leg assembly and therefore alter the height of the seat bottom, and a means for removably locking the lower support member to the upper support member at any of a variety of heights of the leg assembly.

5. The expansible portable bench seat of claim 4 wherein the means for removably locking the lower support member to the upper support member comprises a spring loaded pin in one member alternately engaged in one of a series of spaced holes connection between members.

6. The expansible portable bench seat of claim 1 further comprising an umbrella clamp removably attachable to the seat back at any of a variety of different locations along the length of the seat back, the umbrella clamp comprising a clamp for attachment to the seat back and an umbrella support comprising a series of rods interconnected together by pivot joints and adjustable elbows to allow for multiple angles, heights and positions of an umbrella attached thereto.

7. The expansible portable bench seat of claim 1 further comprising four short legs with rubber pads on a bottom end of the short legs to prevent sinking on soft ground, the short legs attachable to the seat bottom in place of the leg assemblies for use in low to the ground hunting.

8. The expansible portable bench seat of claim 1 further comprising a utility tray removably attachable to a top of the seat back by a pair of hooks hooked over the seat back so that the utility tray hangs down behind the seat back for storing items thereon.

9. The expansible portable bench seat of claim 1 further comprising a foot step removably attachable to the leg assembly so that a user may step on the foot step for reaching higher.

10. The expansible portable bench seat of claim 1 wherein the means for carrying the portable expansible bench seat comprises a carrying bag with a handle.

11. The expansible portable bench seat of claim 1 further comprising at least one seat rest pad attached to the seat bottom, at least one seat rest pad removably attached to the seat back and at least one arm rest pad removably attached to each of the arm rests.

* * * * *