



INTERNATIONAL APPLICATION PUBLISHED UNDER THE PATENT COOPERATION TREATY (PCT)

<p>(51) International Patent Classification ⁶ : G02B 6/26, 6/42, 5/00, G01N 21/17 // 21/55, 33/48</p>	<p>A1</p>	<p>(11) International Publication Number: WO 97/19375 (43) International Publication Date: 29 May 1997 (29.05.97)</p>
<p>(21) International Application Number: PCT/SE96/01522 (22) International Filing Date: 22 November 1996 (22.11.96) (30) Priority Data: 9504206-5 24 November 1995 (24.11.95) SE (71) Applicant (for all designated States except US): BIACORE AB [SE/SE]; S-751 82 Uppsala (SE). (72) Inventors; and (75) Inventors/Applicants (for US only): IVARSSON, Bengt [SE/SE]; Fögderivägen 22, S-740 22 Bålinge (SE). ÖSTLIN, Henrik [SE/SE]; Banérgatan 34, S-752 37 Uppsala (SE). (74) Agents: WIDÉN, Björn et al.; Pharmacia & Upjohn AB, Patent Dept., S-751 82 Uppsala (SE).</p>		<p>(81) Designated States: JP, US, European patent (AT, BE, CH, DE, DK, ES, FI, FR, GB, GR, IE, IT, LU, MC, NL, PT, SE). Published With international search report. Before the expiration of the time limit for amending the claims and to be republished in the event of the receipt of amendments.</p>

(54) Title: OPTICAL COUPLING DEVICE AND METHOD FOR ITS PRODUCTION

(57) Abstract

A replaceable and reusable optical coupling device, suitable for use in a biosensor, for the coupling of light from a first solid optically transparent medium (2) to a second solid optically transparent medium (4) comprises opposite elastic contact portions (6, 7) for contacting the first and second solid media (2, 4) and has a refractive index matching with these media. At least one of the contact portions (6, 7) has a convex surface and is adapted to be compressed when pressed

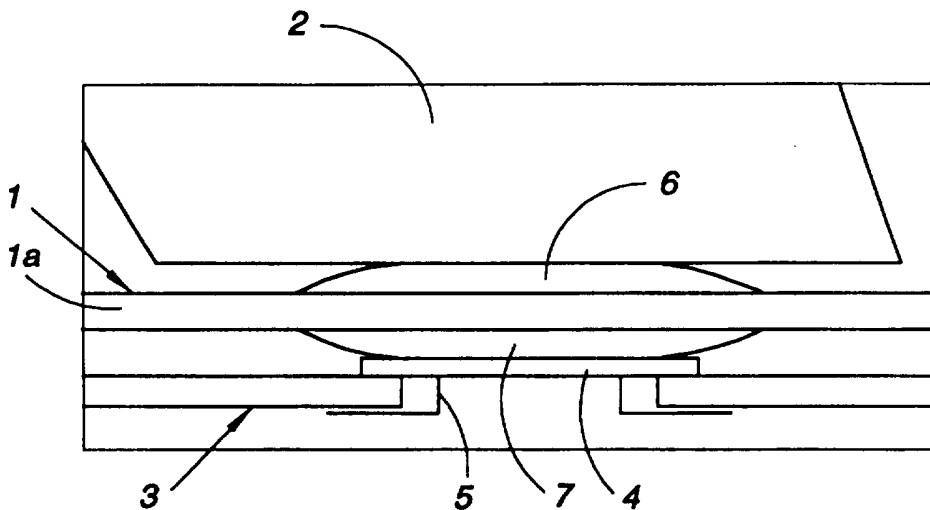

against one of the two solid media (2, 4) to provide an optically coupling contact area. In its non-compressed state, the convex portion has a maximum height over its periphery in the range of about 5 - 280 μm, preferably in the range of about 12 - 140 μm, and a ratio of maximum height to maximum lateral extension in the range of about 0.00008 - 0.05, preferably from about 0.0001 - 0.03. In its compressed state, the convex surface portion is elastically deformed to provide an optical coupling area with uniform light transmission in the range of about 12 to about 5000 mm², preferably in the range about 28 - 1500 mm².

FOR THE PURPOSES OF INFORMATION ONLY

Codes used to identify States party to the PCT on the front pages of pamphlets publishing international applications under the PCT.

AM	Armenia	GB	United Kingdom	MW	Malawi
AT	Austria	GE	Georgia	MX	Mexico
AU	Australia	GN	Guinea	NE	Niger
BB	Barbados	GR	Greece	NL	Netherlands
BE	Belgium	HU	Hungary	NO	Norway
BF	Burkina Faso	IE	Ireland	NZ	New Zealand
BG	Bulgaria	IT	Italy	PL	Poland
BJ	Benin	JP	Japan	PT	Portugal
BR	Brazil	KE	Kenya	RO	Romania
BY	Belarus	KG	Kyrgystan	RU	Russian Federation
CA	Canada	KP	Democratic People's Republic of Korea	SD	Sudan
CF	Central African Republic	KR	Republic of Korea	SE	Sweden
CG	Congo	KZ	Kazakhstan	SG	Singapore
CH	Switzerland	LI	Liechtenstein	SI	Slovenia
CI	Côte d'Ivoire	LK	Sri Lanka	SK	Slovakia
CM	Cameroon	LR	Liberia	SN	Senegal
CN	China	LT	Lithuania	SZ	Swaziland
CS	Czechoslovakia	LU	Luxembourg	TD	Chad
CZ	Czech Republic	LV	Latvia	TG	Togo
DE	Germany	MC	Monaco	TJ	Tajikistan
DK	Denmark	MD	Republic of Moldova	TT	Trinidad and Tobago
EE	Estonia	MG	Madagascar	UA	Ukraine
ES	Spain	ML	Mali	UG	Uganda
FI	Finland	MN	Mongolia	US	United States of America
FR	France	MR	Mauritania	UZ	Uzbekistan
GA	Gabon			VN	Viet Nam

OPTICAL COUPLING DEVICE AND METHOD FOR ITS PRODUCTION**FIELD OF THE INVENTION**

The present invention relates to a replaceable and
5 reusable coupling device for non-permanent coupling of
light between two solid optically transparent media as well
as to the production thereof.

BACKGROUND OF THE INVENTION

The conventional way of making a non-permanent passive
10 (i.e. not refracting or diffracting) light coupling between
two light transmitting elements consists in sealingly
connecting the two elements by an immersion oil, or in some
applications, an uncured silicone rubber composition,
having a suitable refractive index. This requires an
15 accurate amount of the coupling medium to be dispensed,
making necessary either manual handling or mechanical
equipment. The drop-formed residues of immersion oil that
remain after element separation must also be removed from
one or both elements for each new coupling operation to
20 obtain a good light coupling without disturbing enclosed
air bubbles. Such removal of the immersion oil by wiping it
off or other cleaning is besides a messy and time-consuming
procedure which in addition to involving the risk of
scratching the optical surfaces is difficult to automate
25 in, for example, a commercial measuring instrument.
Furthermore, the oil may easily contaminate or smear
instrument parts, optical details and sensing surfaces
which, of course, is a considerable inconvenience,
particularly in commercial type apparatuses.

30 To overcome these inconveniences, WO 90/05317
discloses a reusable optical solid type interface means, or
optointerface, for non-permanent passive coupling of light
between two light transmitting media, which comprises at
least one optically transparent elastic element attached to
35 one or both sides of a solid support. The elastic elements
are adapted to contact the light transmitting media and
have a matching refractive index with respect thereto. In a
simple embodiment, the optointerface is a transparent plate

having a transparent elastic material body attached to each side of the plate. Such an optointerface may, for example, be inserted between a microscope lens and a slide for coupling light therebetween. In this case, the elastic body has a planar contact surface for the lens, the convex shape of the latter providing for air exclusion when the elastic body is compressed for permitting light coupling.

In the case of one or both of the light transmitting media having a planar contact surface, the contact surface or surfaces of the elastic element(s) should preferably be dome-shaped or stepped to prevent the enclosure of air-bubbles when the elastic element(s) is (are) pressed against the respective light transmitting medium. In a specific embodiment described, the optointerface is intended for light coupling in a biosensor system based on surface plasmon resonance (SPR), and more particularly between a coupling prism or lens and a SPR sensor plate forming one wall of one or more flow channels. The SPR biosensor system uses total internal reflection (TIR) of light at a glass/metal interface on the sensor plate. The optointerface consists of a glass or plastic plate having a number of transparent ridges (one for each sample flow channel) of transparent elastic material in an opposed relationship on each side of the plate. Each ridge has a stepped configuration to prevent air pockets from being formed between each ridge and the sensor plate or prism, respectively. Otherwise, the total internal reflection would take place at the prism/air or ridge/air interface. The ridges typically have a width of about 700 μm , a length of about 7 mm, and a spacing of about 500 μm . Such an optointerface with a number of parallel ridges is, however, disadvantageous in that it will tend to scatter the light in the direction orthogonal to the ridges. Also, the positioning of the optointerface in relation to the sensor plate and flow channel is critical. It would therefore be desirable to replace the ridges by a single optical element. However, the necessary width of such an elastic element (about 10 mm) is too large for a stepped surface

configuration to be practically feasible, as it would require too great a compression (and compression force) due to the difficulty of producing sufficiently low steps.

SUMMARY OF THE INVENTION

5 It is therefore an object of the present invention to provide an optical coupling device which is devoid of the above disadvantages and permits the creation of a considerably larger light coupling area than has been possible with the prior art elastic coupling means.

10 According to the present invention, it has now been found that the above object as well as other objects and advantages may be achieved if the elastic coupling element has a convex contact surface with a specifically defined curvature which requires only a moderate compression to
15 provide excellent light coupling with minimal light scattering, reflection losses and light refraction, as well as a minimal variation of the polarization and phase of the light wave.

The present invention therefore provides a replaceable
20 and reusable optical coupling device, suitable for use in a biosensor, for the coupling of light from a first solid optically transparent medium to a second solid optically transparent medium, which device comprises opposite elastic contact portions for contacting said first and second solid
25 media and has a refractive index matching with said media, at least one of said contact portions having a convex surface and being adapted to be compressed when pressed against one of said two solid media to provide an optically coupling contact area. The coupling device is characterized
30 in that (i) in its non-compressed state, said convex surface portion has a maximum height over its periphery in the range of about 5 to about 280 μm , particularly 5 to 280 μm , preferably in the range of about 12 to about 140 μm , especially 12 to 140 μm , and a ratio of maximum height to
35 maximum lateral extension in the range of about 0.00008 to about 0.05, particularly 0.00008 to 0.05, preferably in the range of about 0.0001 to about 0.03, especially 0.0001 to 0.03; and (ii), in its compressed state, said convex

surface portion is elastically deformed to provide an optical coupling area with uniform transmission in the range of about 12 to about 5000 mm², particularly 12 to 5000 mm², preferably in the range of about 28 to about 1500 mm², especially 28 to 1500 mm².

The term "matching" with respect to refractive index as used herein is a relative one and means that the refractive index of the elastic material should be appropriately matched or adapted to the contacting media in accordance with each particular application. For instance, in case the incident light is normal to a planar interfacial contact surface between the light coupling means and the solid medium or media, rather "extensive" differences between the refractive indices of the respective material may be tolerated, whereas only moderate or small refractive index deviations may be allowed in case of applications with obliquely incident light.

The optically transparent elastic material may be any material meeting the specific requirements concerning elasticity, strength, refractive index, etc., for each particular application, and to find suitable materials for a particular application, in view of the disclosure herein, is within the skill of a person skilled in the art. As examples of broad material classes may be mentioned transparent rubber or (cross-linked) elastomers, such as silicone rubber or polybutadiene; and transparent epoxy resins.

The necessary compression force for sufficiently contacting the elastic contact portions with the respective transparent solid medium depends, of course, on the particular elastic material, but is usually from about 0.1 to about 50 N, particularly 0.1 - 50 N, a suitable degree of compression being from about 30% to about 70%, particularly 30 - 70%, preferably from about 40% to about 60%, especially 40 - 60%, of the maximum height of the elastic element in its non-compressed state.

In one embodiment, the convex surface is spherical and concentric, and the radius of curvature is constant.

In another embodiment, the convex surface is aspherical and concentric, and the radius of curvature varies with the angle between the radius and the vertical center axis of the convex surface.

5 In still another embodiment, the convex surface is composed of several different concentric convex segments of different radii of curvature, the transition between the different convex segments being stepless (i.e. a continuous curvature).

10 In yet another embodiment, the convex surface is cylindrically spherical, and the radius of curvature is in a plane normal to the longitudinal axis of the cylinder.

In the first-mentioned case of a spherical convex surface, the arc angle [$2 \cdot \arcsin(\text{half edge chord}/\text{radius of curvature})$] is in the range of about 0.02° to about 25° , particularly 0.02° to 25° , preferably in the range of about 0.03° to about 9° , especially 0.03° to 9° . This may, for example, be compared to the corresponding arc angle of 60° for a transparent elastic ball of 2 mm radius of curvature used in the prior art to couple light between two optical fiber ends.

20 For an elastic body with a spherical convex surface having the radius of curvature R, the compression ΔT thereof by a planar solid medium may be calculated from the equations:

$$R = \frac{r^2 \cdot E \cdot A}{4 \cdot T_0 \cdot (1 + \nu) \cdot F} \qquad \Delta T = \frac{2 \cdot T_0 \cdot (1 + \nu) \cdot F}{E \cdot \pi \cdot r^2}$$

30 where r is the radius of the intermediate or optocoupling surface, A is the area thereof, E and ν are the elasticity modulus and contraction modulus, respectively of the optocoupling material, T_0 is the total thickness, or height, of the elastic optocoupling material, and F is the force by which the solid optical medium is pressed against the elastic optocoupling material.

For a convex surface consisting of several concave segments of different radii, R_n , different convexities may be defined depending on R_n . For example, a constant R_n within a certain arc angle range gives a symmetrical
5 aspherical convexity, whereas R_n being a function of an arc angle gives e.g. a parabolic convexity, and R_n being a function of the centre distance along a (straight or curved) line gives a cylindrical convexity.

In another aspect, the present invention provides a
10 method of producing an optical coupling component as described above by moulding the convex surface against a corresponding concave wall of a mould cavity. Preferably, the concave mould cavity wall has been produced by moulding against a membrane or plate deformed mechanically to a
15 corresponding convex curvature. Alternatively, the concave mould cavity wall may, of course, be produced by grinding or polishing a mould substrate surface.

The optical coupling device of the invention may suitably be used for coupling of light between an
20 instrument-based stationary optical element and a replaceable or disposable optical sensor element for sensor principles based on total internal reflection (TIR) in, for example, absorbance reflectometry (detecting intensity of polarised light component); polarometry (detecting the
25 polarisation state of the light); interferometry (detecting the phase or wavefront cooperation of the light); and fluorescence. A common use for such instrumentation is in chemical and biochemical analyses.

Reflectometry includes attenuated total reflection
30 infrared spectroscopy (ATR-IR), surface plasmon resonance reflectometry (SPR) (both angle- and wavelength-scanned), long-range plasmon resonance (both angle- and wavelength-scanned), internal Brewster angle reflectometry. Polarometry includes internal reflection ellipsometry.
35 Fluorescence includes TIR fluorescence (TIRF).

The optical coupling device of the invention may further be used for coupling between a first optical element and a replaceable or disposable second optical

sensor element based on resonant guided mode detection including those based on frustrated total reflection (FTR) (resonant cavity); see e.g. Harrick, N.J., Internal Reflection Spectroscopy. Chapter 2, page 163. Harrick Scientific Corporation, New York 1987.

The novel optical coupling component of the present invention offers several advantages in relation to those of the prior art.

For example, due to the continuous optical coupling area of the coupling component, in an optical detection system like the SPR-based system specifically described in the above-mentioned WO 90/05317, it is not necessary to guide the coupling component mechanically to match defined parts of a matrix photodetector and defined parts of a sensor chip.

Also, the whole sensor area of a sensor chip may be monitored rather than being restricted to the parts of the sensor chip that the matrix photodetector actually "sees". Thus, different sensor areas within a sensor chip may be positioned randomly and be monitored, provided that the sensor areas are imaged with appropriate size in relation to the matrix photodetector elements.

Further, monitoring and visualization, respectively, with a high lateral density of localized detection within a sensor area is made possible. Thereby it will be possible to monitor a large amount of individual sensor surface zones to provide for multi-analyte assays or multi-site monitoring.

In relation to the prior art coupling component with a stepped surface, the optical coupling component of the present invention has the advantages that disturbing light scattering and/or light refraction caused by refractive index steps and steep refractive index gradients are avoided.

In the following, the invention will be described in more detail with reference to some non-limiting embodiments, reference being made to the accompanying drawings.

SHORT DESCRIPTION OF THE DRAWINGS

Figs. 1A and 1B are schematic side views of a first embodiment of the optical coupling device of the invention inserted between a prism and a sensor chip, before and
5 after being pressed therebetween, respectively.

Fig. 1C is an enlarged part of the view in Fig. 1B.

Fig. 2 is a schematic partial view of a second embodiment of the optical coupling device compressed between a prism and a sensor chip.

10 Fig. 3 is a schematic partial view of a third embodiment of the optical coupling device attached to a sensor chip and compressed between a prism and a sensor chip.

Fig. 4 is a schematic partial view of a fourth
15 embodiment of the optical coupling device attached to a prism and compressed between the prism and a sensor chip.

Fig. 5 is a schematic partial view of a fifth embodiment of the optical coupling device, including immersion oil enclosed within a transparent cover,
20 compressed between a prism and a sensor chip.

Figs. 6A and 6B are schematic side views of a sixth embodiment of the optical coupling device integral with a prism and a sensor chip, before and after, respectively, being pressed against a fluidic system.

25 Fig. 6C is an enlarged part of the view in Fig. 6B.

Figs. 7A to 7H are partial sectional views of two cooperating parts of a moulding apparatus at different stages of a process for producing a coupling device of the invention.

30 Fig. 8 is a partial sectional view of parts of another embodiment of moulding apparatus for producing a coupling device of the invention.

Fig. 9A is a schematic sectional view of parts of still another embodiment of moulding apparatus for
35 producing a coupling device of the invention.

Fig. 9B is a section along A-A in Fig. 9A;

Fig. 10A is a varied arrangement of the moulding apparatus parts in Fig. 9; and

Fig. 10B is a section along B-B in Fig. 10A.

In the drawings, identical parts are designated by the same reference numerals.

DETAILED DESCRIPTION OF THE INVENTION

5 Fig. 1A illustrates a coupling device 1, hereinafter often called optointerface, inserted between a prism 2 and a sensor element 3. In Fig. 1B, the optointerface 1 is compressed between the prism 2 and the sensor element 3. The sensor element 3 includes a sensor chip 4, the lower
10 face of which forms a sensing surface to be contacted with a sample. To this end the sensor chip 4 is docked against a fluidic block indicated at 5. Light is coupled to the opposite side of the sensor chip 4 via the prism 2 and the optointerface 1 such that it is totally reflected at the
15 sensor chip. The sensor chip may, for example, be adapted to surface plasmon resonance (SPR) detection. In such a case the chip may be a glass plate having a thin layer of an SPR-supporting metal film thereon, e.g. gold. The metal layer may have suitable ligands immobilized thereto to form
20 the sensing surface of the sensor chip. For more detailed information on SPR-based detection systems to be used with the sensor element as well as on the sensor element and its sensing surface, it may be referred to WO 90/05295 (detection system), WO 90/05305 (sensor element) and WO
25 90/05303 (sensing surface), the full disclosures of which are incorporated by reference herein.

As is better shown in Fig. 1C, the optointerface 1 consists of a transparent plate 1a, e.g. of glass or plastic, which has respective layers 6, 7 of transparent
30 elastic material, such as silicone, attached to each side thereof. The elastic material has a matching refractive index with respect to the material of the transparent plate, the prism and the sensor chip. The layers 6, 7 each have a convex surface of a curvature as defined above. The
35 optointerface in Figs. 1A to 1C may thus be said to form a bi-convex optical coupling component.

The optointerface shown in Figs. 1A-C may alternatively be made as an integral component of a single

material. This is illustrated in Fig. 2 which shows an integral elastic optointerface 8 compressed between a prism 2 and a sensor chip 4.

Fig. 3 illustrates an optointerface variant where an elastic material body 9 with a convex surface is attached to a sensor chip 10 to provide an integral sensor chip/convex optocoupling component. This variant has the advantage that the optointerface is replaced whenever the sensor chip is replaced, i.e. the use of a fresh optointerface is always insured.

Another integral type optocoupling component is illustrated in Fig. 4 where an elastic material body 11 with a convex surface is attached to a replaceable TIR element, such as a prism 12, to provide an integral TIR element/convex optocoupling component.

Still another optointerface variant is shown in Fig. 5. In this embodiment a separate optocoupling component is formed by a carrier structure 13 supporting a liquid transparent medium 14, such as a conventional type immersion oil, enclosed within a transparent cover 15. In the illustrated case an expansion reservoir 16 is connected to the medium 15 via a conduit 17. This optocoupling component has the advantage of requiring a low docking pressure to provide the desired optical coupling.

Figs. 6A-C illustrate an embodiment where an integral sensor chip/optocoupling component 18, like that shown in Fig. 3, is resiliently mounted, via an elastic sealing or elastic pads 20, in a TIR element 19 to be docked against a fluidic block 5.

In all the embodiments described above at least one of the two large contact surfaces of the optocoupling material is continuously convex in the non-compressed state. When subjected to compression, each convex surface is microscopically deformed as the contact area or areas to the planar optical element in question (such as sensor chip and/or prism) are successively increased until the optocoupling component forms a planar homogenous structure with optical transmission within a homogeneous continuous

area, typically of the size 0.3 cm^2 to 10 cm^2 . In the compression, the contact surface of the elastic optocoupling material successively "wets" the contacted prism or sensor chip such that air is displaced, a
5 continuous optointerface thereby being formed. The optical coupling contacting is reversible, i.e. when the applied compression force is sufficiently reduced, the elastic optocoupling material successively recovers its convex surface shape, the optocoupling material lifting itself
10 from the contact surface. This release is propagated towards the center of the contact surface. The light coupling obtained with the coupling device insures that a minimal disturbance of light ray angles, intensity, polarization and phase is obtained.

15 While in the above described embodiments the elastic optocoupling material is attached to a chip or prism, it may as well be attached to other elements, such as e.g. a planesided lens, a cuvette, microcuvette array or a waveguide, such as e.g. an optical fiber, a rectangular
20 slab type waveguide or a waveguide element integrated in a substrate.

Suitably, one or more stops are provided on the surface or surfaces to which the elastic optocoupling material is attached so that compression thereof is only
25 permitted down to the stop or stops, i.e. a fixed minimum compressed thickness of the optocoupling material is insured. In this way, further compression (and cold flow) of the optocoupling material in case of a temperature rise is avoided.

30 A convenient method of producing the optointerfaces described above is by means of moulding cavities which are created by contacting curable low viscosity materials with a harder material of good surface fineness and flexed in a controlled fashion. These harder materials may, for
35 example, be metal or glass plates or sheets or plastic films. Exemplary curable materials are UV- or thermally curable silicone gels, 2-component curable plastics, and 1-component UV-curable acrylic plastics.

An example of such production of a biconvex optointerface is described below with reference to Figs. 7A to 7H.

5 A moulding apparatus comprising two vertically opposed tool parts, a lower tool part 21 and an upper tool part 22, is used (Fig. 7A).

10 These two tool parts may, for example, be part of a multiprocess chamber of the type described in Swedish patent application no. 9401961-9. Such a multiprocess chamber comprises a number of blocks which can be assembled to form the walls of a closed cavity. Each block includes a package of a number of bar members which together form a wall of the cavity. In each package the bar members are individually displaceable lengthwise to create any desired
15 shape of the cavity.

The lower tool part 21 in Figs. 7A-D has a top recess 23 with a central protrusion 24, the rim 25 of recess 23 forming a stop frame. The upper tool part 22 has an open cone-shaped cavity 26 connected to a material filling
20 channel 27.

With reference to Fig. 7B, a flexible disc 28 is placed on the protrusion 25. Typically, the height of the protrusion is from about 1 to about 5 times the desired compression of the elastic optocoupling material of the optical coupling device to be produced. The two tool parts
25 are then pressed against each other such that the bottom edge of the upper tool part 22 contacts the rim 25 of the lower tool part 21, as shown in Fig. 7C, the disc 28 thereby being bent to a convex configuration with a controlled radius of curvature. Subsequent filling of a curable material, e.g. UV-curable PMMA, through the channel 27 results in the formation of a conical plug 29 in the upper tool part 22; see Fig. 7D. This plug is then irradiated with UV light for curing thereof, either through
30 the channel 27 or after the two tool parts 21 and 22 have been separated. The deformed disc 28 is then removed from the plug 29. If necessary, a release agent is used on the
35

top face of disc 28 to reduce the adherence of plug 29 thereto.

The above described procedure is repeated to produce another identical upper tool part 22 with a plug 29
5 therein. The two tool parts, or mould halves, 22a and 22b, are placed opposite each other with a glass plate 30 inserted between them as shown in Fig. 7E. Predetermined volumes 31 and 32 of an optoelastic material, such as e.g. a UV-curing silicone gel, are then placed on (i) the glass
10 plate 30 and (ii) the lower mould half 22b. The two mould halves 22a, 22b are then brought towards each other to close a moulding cavity 33 defined by the opposed curved surfaces of the respective plugs 29a and 29b, as shown in Fig. 7G, whereupon UV irradiation of the silicone gel parts
15 31, 32 is effected for curing thereof. The tool parts 22a, 22b are then separated to release the moulded optointerface component 34 consisting of a glass plate 30 with a convex-surfaced optoelastomer body 31, 32 on either face thereof.

Using the multiprocess chamber referred to above, a
20 plurality of optointerfaces 34 may be produced simultaneously.

A similar technique to that described above may be used for moulding a convex elastic element body directly on a waveguide, e.g. in the form of an optical fiber of the
25 same or another material, such as a conventional waveguide or optical fiber material.

An alternative way of deforming the disc 28 to the shape shown in Figs. 7A-7D is illustrated in Fig. 8, which uses subpressure or overpressure to deform the disc. To
30 this end disc 28 is pressed between the top of a lower tool part 35 having a central bore 36, and an upper tool part 37 similar to the upper tool part 22 in Figs. 7A-H. A sealing element 38 is provided in an annular recess on the top edge of lower tool part 22. By the application of vacuum to the
35 upper tool part 37, or overpressure to the lower tool part 35, a desired controlled deformation of the disc 28 may be obtained. An optional adjustable stop member for

controlling the maximum deformation of disc 28 is indicated at 39.

5 A more controlled deformation of a disc or membrane may be obtained by deforming the latter between two blocks of bar members in the above-mentioned multiprocess chamber. This is schematically illustrated in Figs. 9A-B and 10A-B.

10 Figs. 9A and 9B illustrate controlled deformation of a disc or membrane 40 between two opposed sets of 5 x 5 bar members 41 and 42. By appropriate positioning of pegs or pins 43 on top of selected bar members and individual adjustment of the bar members, a well controlled deformation of the membrane 40 may be obtained, in the illustrated case of a spherical convexity.

15 Figs. 10A and 10B schematically illustrate an arrangement for obtaining a cylindrically convex deformation of the membrane 40 by loading the membrane by a number of parallel ridges 44 to obtain line-loading of the membrane rather than single-point loading as in the embodiment shown in Figs. 9A and 9B.

20 The invention is, of course, not restricted to the embodiments described above and specifically shown in the drawings, but many modifications and changes may be made within the scope of the present inventive concept as defined in the following claims.

25

CLAIMS

1. A replaceable and reusable optical coupling device, suitable for use in a biosensor, for the coupling of light
5 from a first solid optically transparent medium (2) to a second solid optically transparent medium (4) and comprising opposite elastic contact portions (6, 7) for contacting said first and second solid media (2, 4) and having a refractive index matching with said media, at
10 least one of said contact portions (6, 7) having a convex surface and being adapted to be compressed when pressed against one of said two solid media (2, 4) to provide an optically coupling contact area, characterized in that (i) in its non-compressed state, said convex surface portion
15 has a maximum height over its periphery in the range of about 5 to about 280 μm , preferably in the range of about 12 to about 140 μm , and a ratio of maximum height to maximum lateral extension in the range of about 0.00008 to about 0.05, preferably from about 0.0001 to about 0.03, and
20 (ii), in its compressed state, said convex surface portion is elastically deformed to provide an optical coupling area with uniform transmission in the range of about 12 to about 5000 mm^2 , preferably in the range about 28 to about 1500 mm^2 .

25

2. The optical coupling device according to claim 1, characterized in that said convex-surface contact portion is adapted to be compressed by a force in the range of about 0.1 to about 50 N.

30

3. The optical coupling device according to claim 1 or 2, characterized in that in its compressed state, said maximum height of the convex-surface contact portion is reduced by from about 30 to about 70%, preferably from about 40 to
35 about 60% of the non-compressed height.

4. The optical coupling device according to claim 1, 2 or 3, characterized in that said convex surface is spherical and concentric, the radius of curvature being constant.
- 5 5. The optical coupling device according to claim 4, characterized in that the arc angle of said convex surface is in the range of about 0.02° to about 25° , preferably about 0.03° to about 9° .
- 10 6. The optical coupling device according to claim 1, 2 or 3, characterized in that said convex surface is aspherical and concentric, the radius of curvature varying with the angle between the radius and the vertical center axis of the convex surface.
- 15 7. The optical coupling device according to claim 1, 2 or 3, characterized in that said convex surface is composed of several different concentric convex segments of different radii of curvature, the transitions between these different convex segments being substantially stepless.
- 20 8. The optical coupling device according to claim 1, 2 or 3, characterized in that said convex surface is cylindrically spherical, the radius of curvature being in a plane normal to the longitudinal axis of the cylinder.
- 25 9. The optical coupling device according to claim 8, characterized in that the radius of curvature varies along the cylinder.
- 30 10. The optical coupling device according to any one of claims 1 to 9, characterized in that said first solid medium causes total internal reflection, the total internal reflection within the contact portion with said first solid medium being transferred to the non-contacted area of said second solid medium.
- 35

11. The optical coupling device according to any one of claims 1 to 10, characterized in that the device comprises two convex surface bodies (6, 7) of elastic material mounted to the opposite faces of a planar transparent film or plate (1a) having a refractive index matching with the convex surface bodies (6, 7).

12. The optical coupling device according to claim 11, characterized in that said elastic material bodies (6, 7) and said transparent film or plate (1a) are of the same material.

13. The optical coupling device according to any one of claims 1 to 10, characterized in that the device consists of a convex-surface body of elastic material (9; 11) and is attached to one of said first and second solid media (10; 12).

14. The optical coupling device according to claim 13, characterized in that said convex-surface body (9) is attached to the back-side of a sensor chip substrate (10).

15. The optical coupling device according to claim 13, characterized in that said convex-surface body (11) is attached to a total internal reflection (TIR) member (12).

16. The optical coupling device according to claim 13, characterized in that said convex-surface body is attached to a frustrated total internal reflection member, such as a resonant cavity device.

17. The optical coupling device according to claim 13, characterized in that said convex-surface body is attached to a waveguide member, such as an optical fiber, a rectangular slab type waveguide or a waveguide element integrated in a substrate.

18. The optical coupling device according to any one of claims 1 to 10, characterized in that the device comprises an integral transparent body (8) of elastic material with two opposed convex contact surfaces for said first and second solid media (2, 4).
19. The optical coupling device according to any one of claims 11 to 18, characterized in that stop means are provided on the solid medium surface to which the elastic material body is attached to restrict the maximum compression of the elastic material body.
20. The optical coupling device according to any one of claims 1 to 19, characterized in that the device comprises at least one body consisting of a transparent solid cover (15) enclosing a liquid transparent medium (14), both said cover (15) and said medium (14) having substantially identical refractive indices.
21. A method of producing an optical coupling device according to any one of claims 1 to 19, characterized by moulding said convex surface against a corresponding concave wall of a mould cavity (33).
22. The method according to claim 21, characterized in that said concave mould cavity wall has been produced by moulding against a membrane or plate (28) deformed mechanically to a corresponding convex curvature.
23. The method according to claim 22, characterized in that said membrane or plate (28) is deformed by a single point-load on the membrane or plate.
24. The method according to claim 22, characterized in that said membrane or plate is deformed by a number of point-loads on the membrane or plate.

25. The method according to claim 22, characterized in that said membrane or plate is deformed by at least one surface load on the membrane or plate.
- 5 26. The method according to claim 22, characterized in that said membrane or plate is deformed by at least one linear load on the membrane or plate.
- 10 27. Use of an optical coupling device according to any one of claims 1 to 10 in apparatus for performing chemical and biochemical analyses using an optical detection principle based on total internal reflection or frustrated total reflection.

1/9

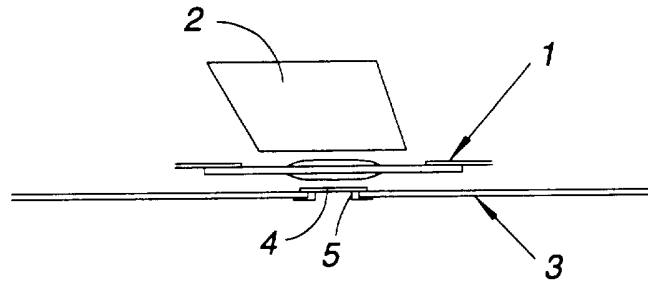

Fig. 1A

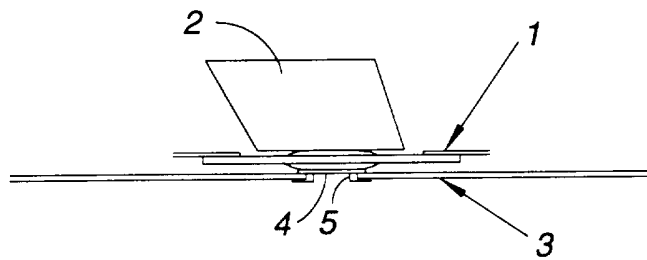

Fig. 1B

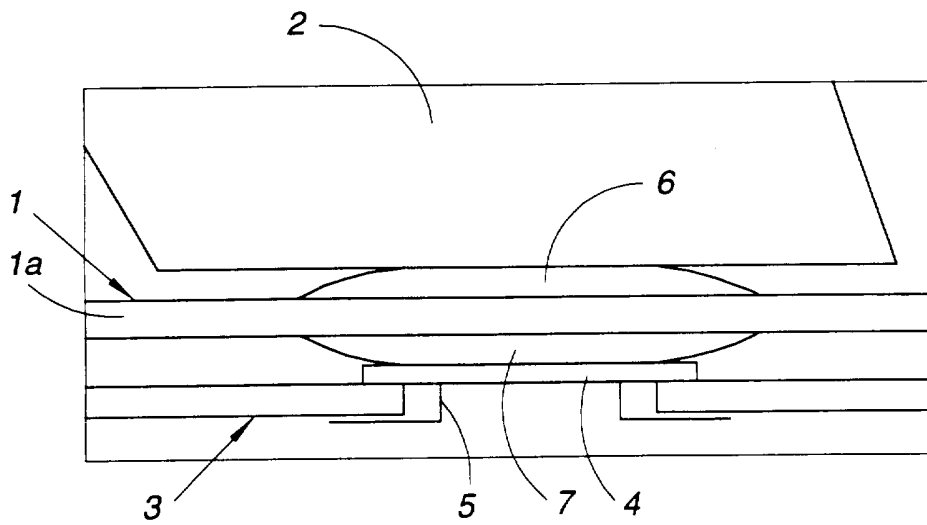
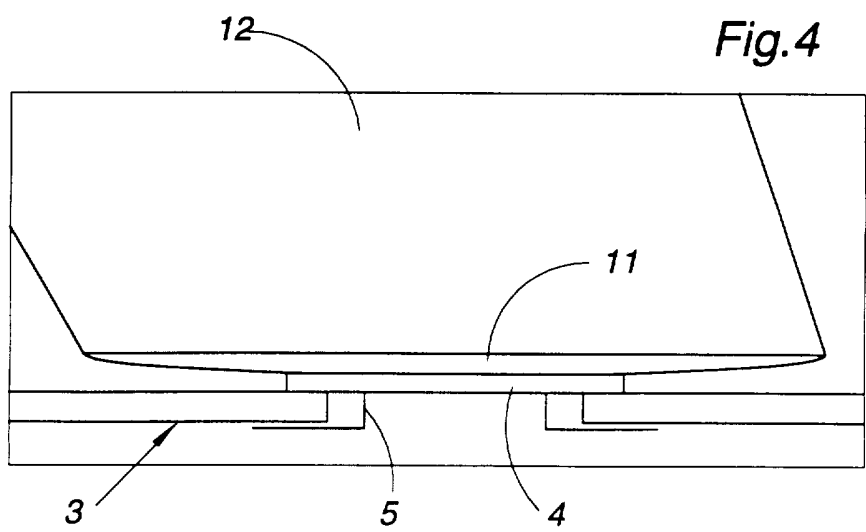
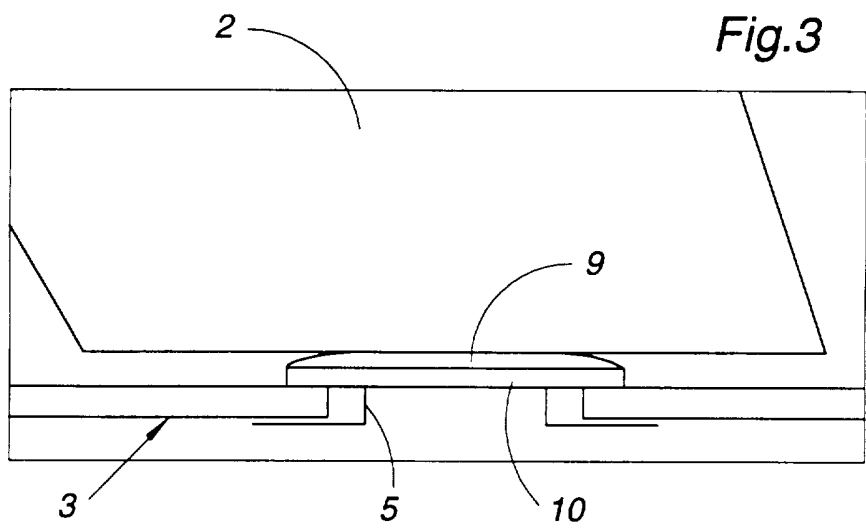
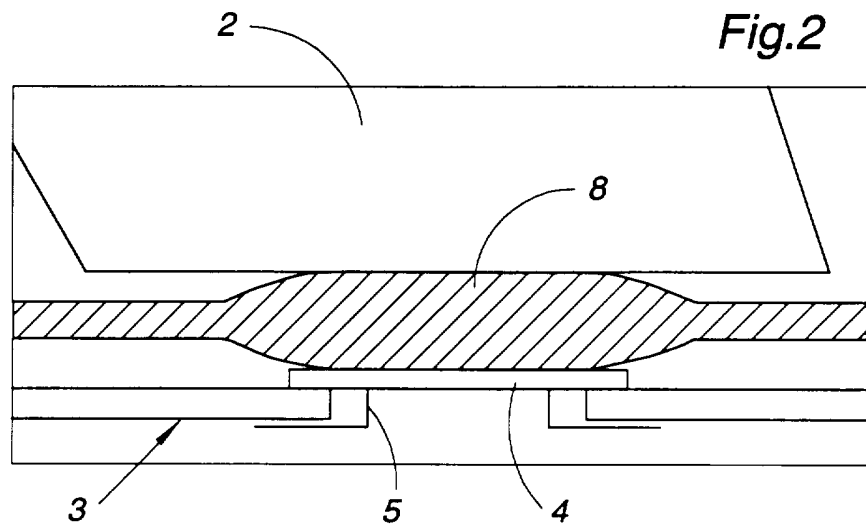

Fig. 1C



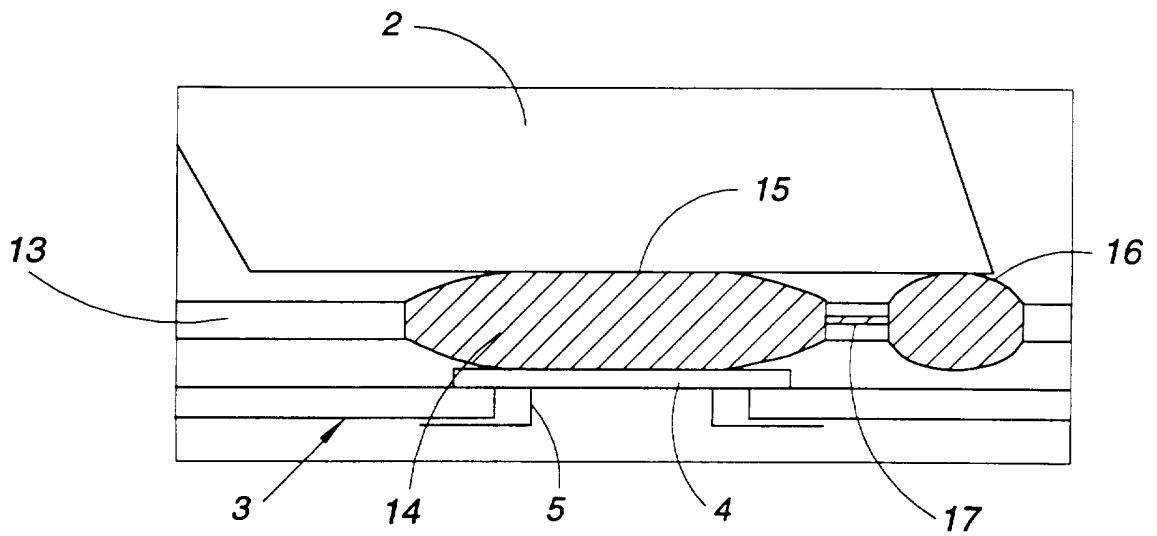
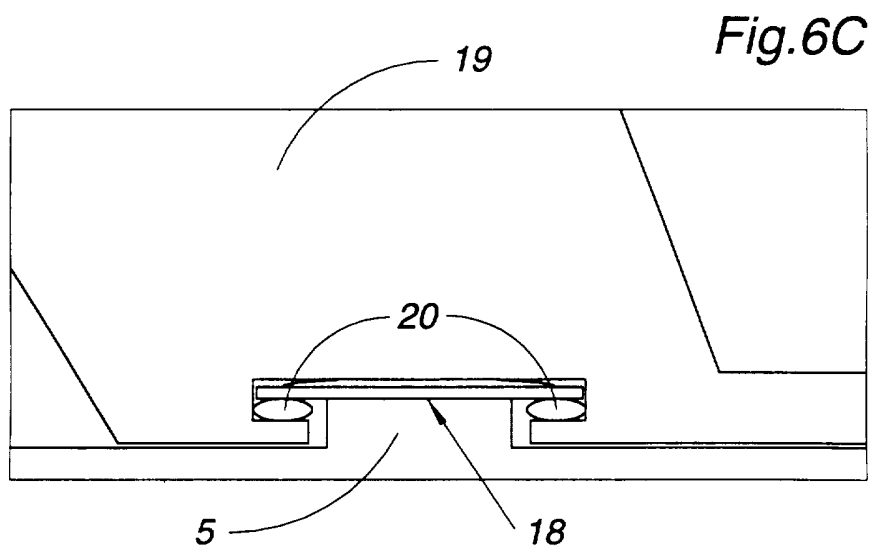
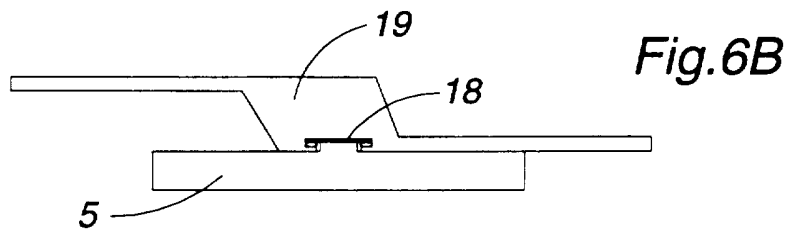
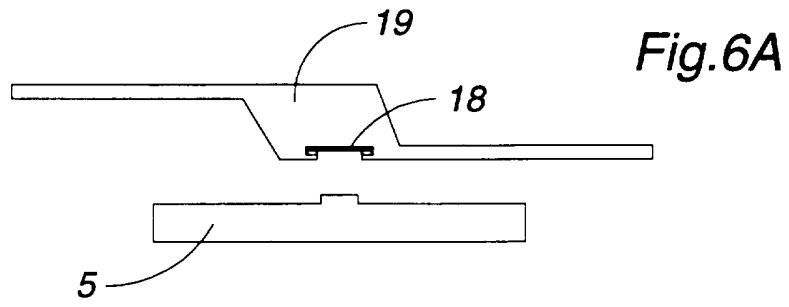
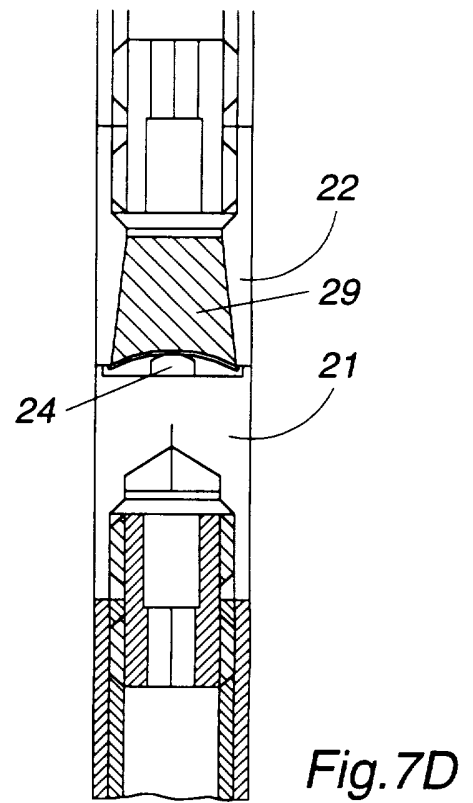
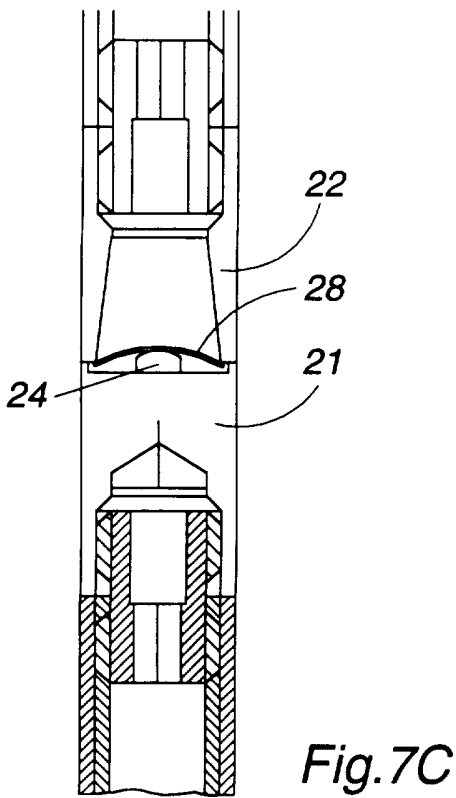
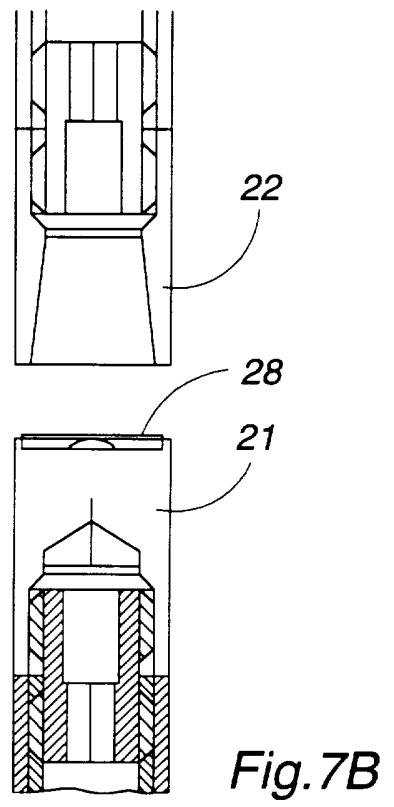
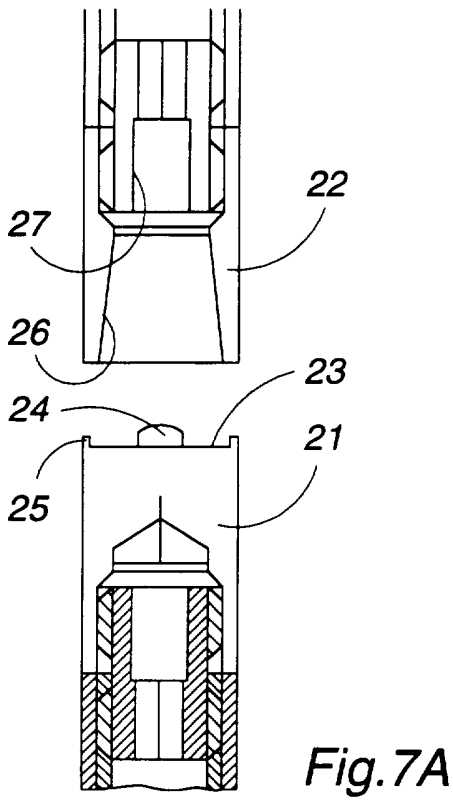

Fig.5

4/9





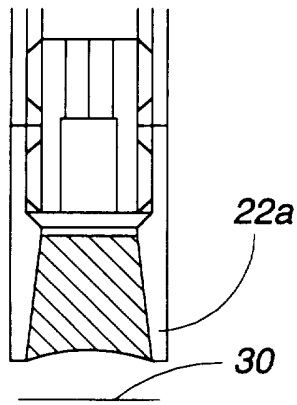

Fig. 7E

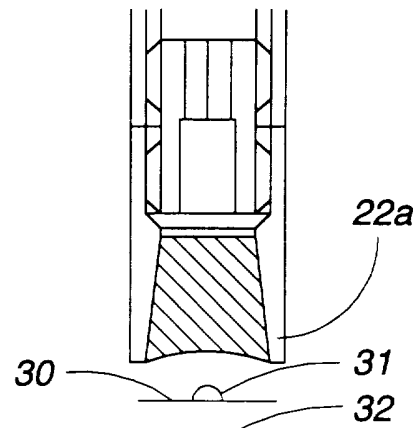
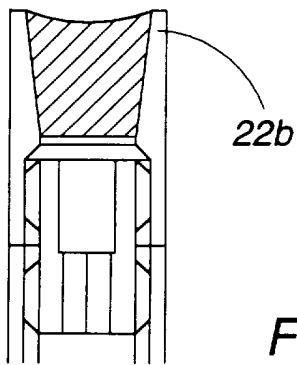

Fig. 7F

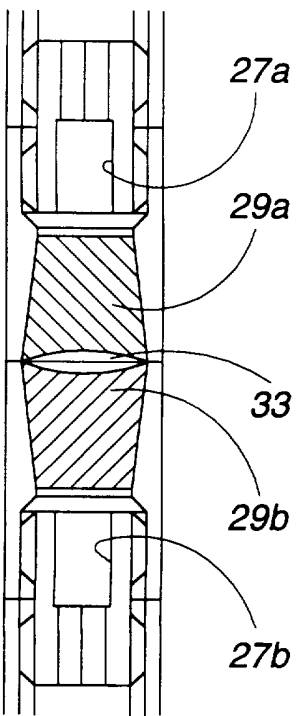
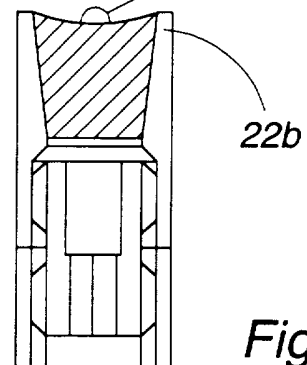

Fig. 7G

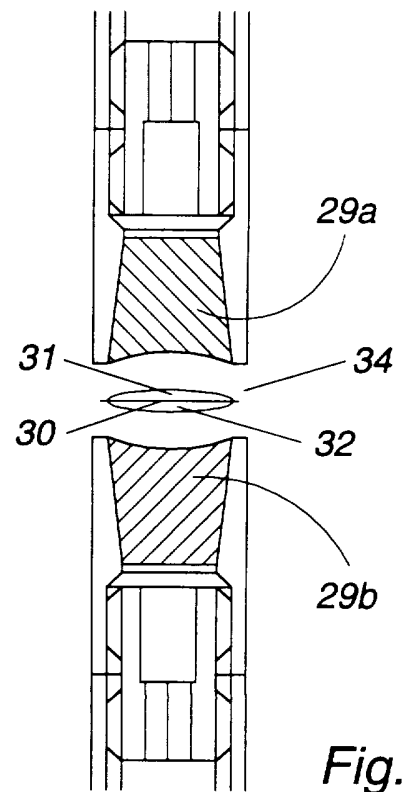

Fig. 7H

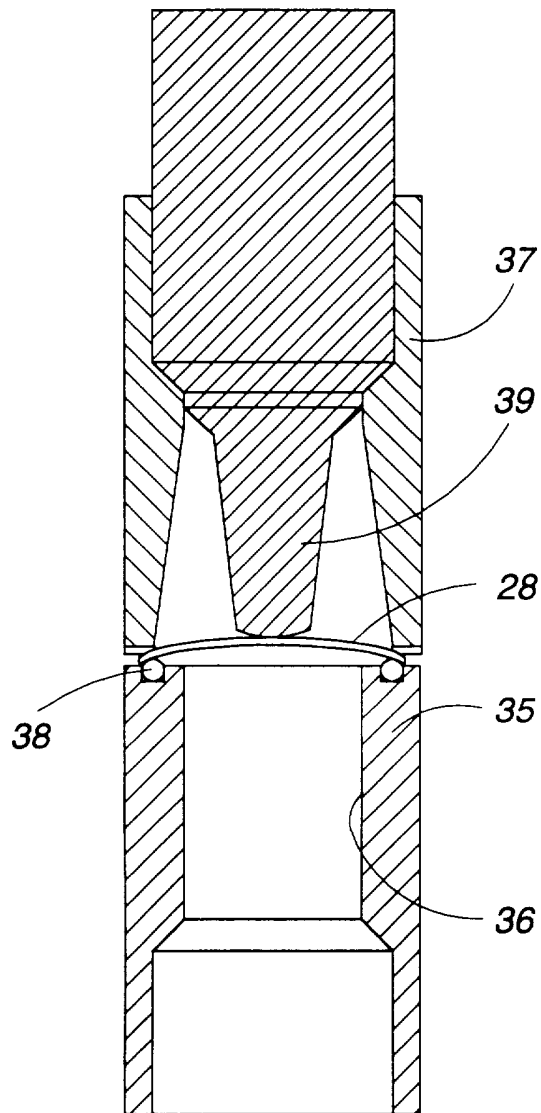

Fig.8

8/9

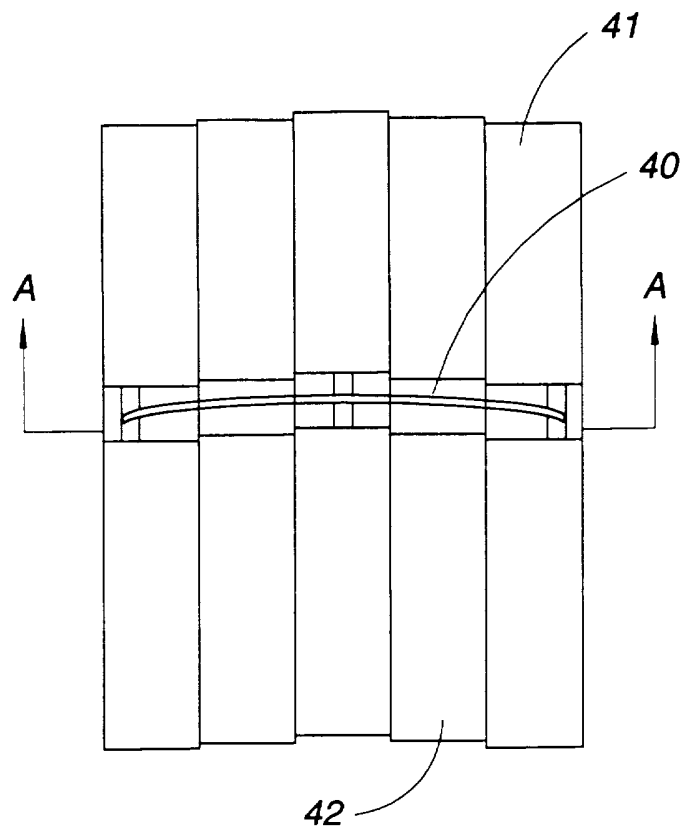

Fig.9A

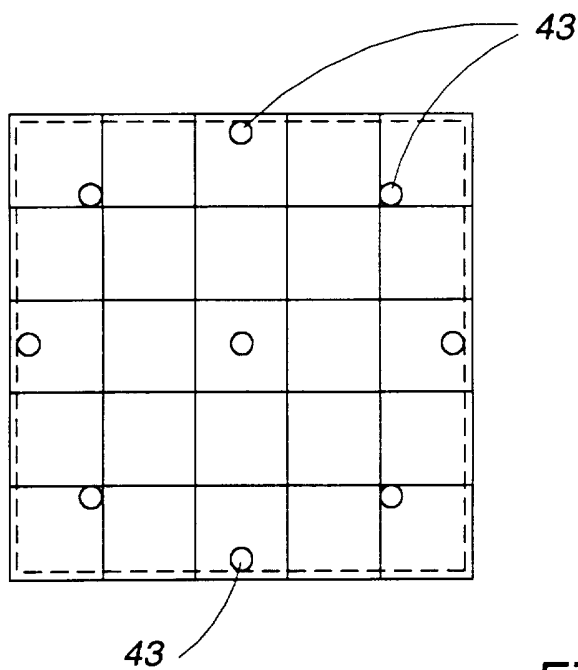

Fig.9B

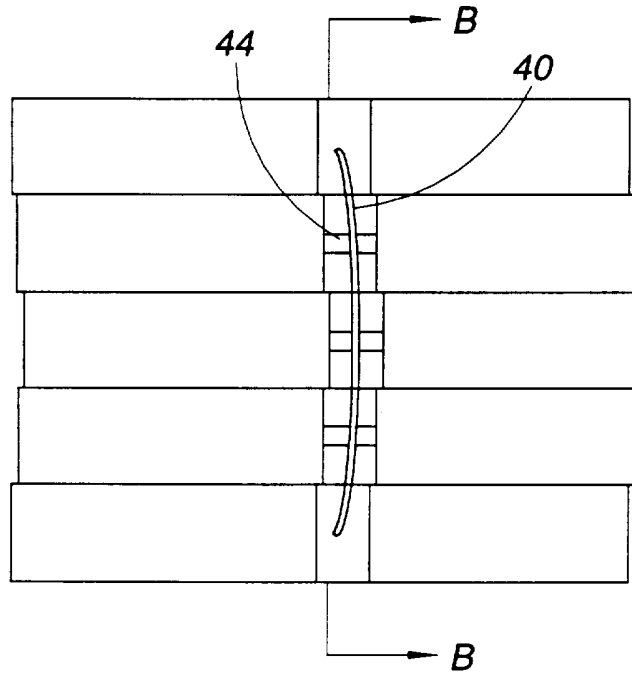

Fig. 10A

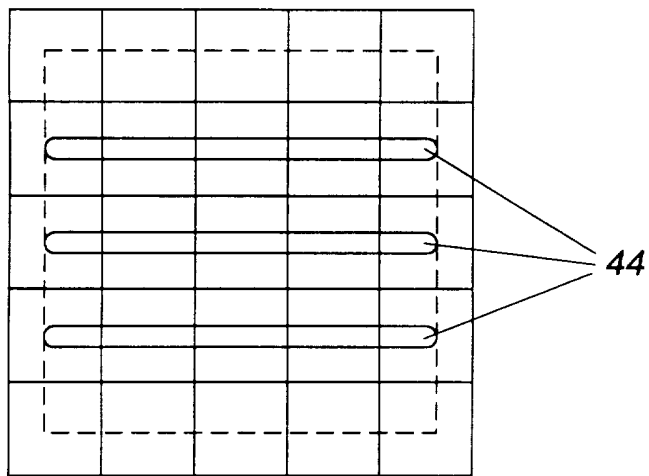

Fig. 10B

INTERNATIONAL SEARCH REPORT

International application No.

PCT/SE 96/01522

A. CLASSIFICATION OF SUBJECT MATTER

IPC6: G02B 6/26, G02B 6/42, G02B 5/00, G01N 21/17 // G01N 21/55, G01N 33/48
According to International Patent Classification (IPC) or to both national classification and IPC

B. FIELDS SEARCHED

Minimum documentation searched (classification system followed by classification symbols)

IPC6: G01N, G02B

Documentation searched other than minimum documentation to the extent that such documents are included in the fields searched

SE,DK,FI,NO classes as above

Electronic data base consulted during the international search (name of data base and, where practicable, search terms used)

C. DOCUMENTS CONSIDERED TO BE RELEVANT

Category*	Citation of document, with indication, where appropriate, of the relevant passages	Relevant to claim No.
A	WO 9005317 A1 (PHARMACIA AB), 17 May 1990 (17.05.90), abstract, see claims --	1-27
A	US 4695871 A (Y. TSUNODA ET AL), 22 Sept 1987 (22.09.87), abstract, see claims -- -----	1-27

 Further documents are listed in the continuation of Box C.

 See patent family annex.

* Special categories of cited documents:

- "A" document defining the general state of the art which is not considered to be of particular relevance
 "E" earlier document but published on or after the international filing date
 "L" document which may throw doubts on priority claim(s) or which is cited to establish the publication date of another citation or other special reason (as specified)
 "O" document referring to an oral disclosure, use, exhibition or other means
 "P" document published prior to the international filing date but later than the priority date claimed

"T" later document published after the international filing date or priority date and not in conflict with the application but cited to understand the principle or theory underlying the invention

"X" document of particular relevance: the claimed invention cannot be considered novel or cannot be considered to involve an inventive step when the document is taken alone

"Y" document of particular relevance: the claimed invention cannot be considered to involve an inventive step when the document is combined with one or more other such documents, such combination being obvious to a person skilled in the art

"&" document member of the same patent family

Date of the actual completion of the international search

19 March 1997

Date of mailing of the international search report

02-04-1997

Name and mailing address of the ISA/
Swedish Patent Office
Box 5055, S-102 42 STOCKHOLM
Facsimile No. +46 8 666 02 86

Authorized officer

Magnus Westöö
Telephone No. +46 8 782 25 00

INTERNATIONAL SEARCH REPORT
 Information on patent family members

04/03/97

International application No.
 PCT/SE 96/01522

Patent document cited in search report	Publication date	Patent family member(s)	Publication date
WO 9005317 A1	17/05/90	DE 68912343 D,T	05/05/94
		EP 0442921 A,B	28/08/91
		SE 0442921 T3	
		EP 0534941 A	07/04/93
		JP 4501462 T	12/03/92
		JP 4504765 T	20/08/92
		SE 462408 B,C	18/06/90
		SE 8804075 A	10/11/88
		US 5164589 A	17/11/92
		US 5313264 A	17/05/94
WO 9005295 A	17/05/90		

US 4695871 A	22/09/87	DE 3331451 A,C	01/03/84
		GB 2127220 A,B	04/04/84
		JP 1780982 C	13/08/93
		JP 4068790 B	04/11/92
		JP 59040575 A	06/03/84
		JP 59123263 A	17/07/84
