

*J. K. Derby,*  
*Jointing Staves.*

*N<sup>o</sup> 15,285.*

*Patented July 8, 1856.*

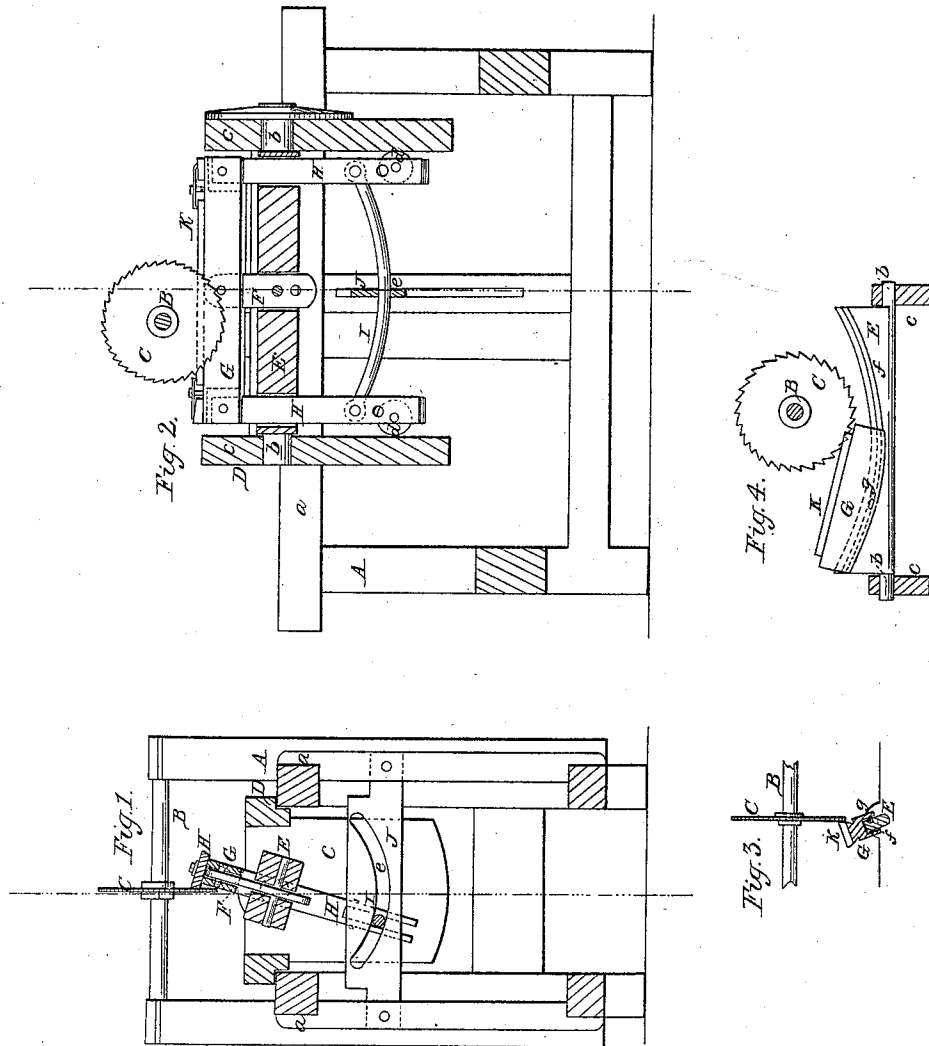

# UNITED STATES PATENT OFFICE.

J. K. DERBY, OF JAMESTOWN, NEW YORK.

## STAVE-JOINTER.

Specification of Letters Patent No. 15,285, dated July 8, 1856.

*To all whom it may concern:*

Be it known that I, J. K. DERBY, of Jamestown, in the county of Chautauqua and State of New York, have invented a new and Improved Machine for Jointing Staves; and I do hereby declare that the following is a full, clear, and exact description of the same, reference being had to the annexed drawings, making a part of the specification, in which—

Figure 1, is a transverse vertical section of my improvement (*x*), (*x*), Fig. 2, showing the plane of section. Fig. 2, is a longitudinal vertical section of the same, (*y*), (*y*), Fig. 1, showing the plane of section. Figs. 3 and 4 are sections showing a modification of my improvement.

My invention consists in properly jointing staves or giving them the necessary "bilge," by placing the staves upon a vibrating or tilting bed which is operated by a pattern or guide as will be presently shown and described so that the stave will be thrown or placed in proper relative positions with the saw to produce the effect desired.

To enable others skilled in the art to fully understand and construct my invention, I will proceed to describe it.

A, represents a rectangular frame which may be constructed in any proper manner to support the working parts.

B, represents a saw shaft or arbor, the ends of which work in proper bearings on the upper ends of uprights attached to the frame, A.

C, is a circular saw placed on the shaft or arbor, B.

D, is a carriage which is fitted in the frame, A, and works on the top pieces, (*a*), (*a*), of the frame. In the carriage, D, a bar, E, is attached longitudinally; said bar having a journal, (*b*), at each end; the journals fitting in the front and back cross pieces, (*c*) (*c*), of the carriage and turning freely therein. To the center of the bar, E, an upright, F, is attached; and G, is a bed, the center of which is pivoted to the upper end of the upright, F. The bed, G, is merely a rectangular bar nearly equal in length to the bar, E. To each end of the bed, G, there is pivoted a pendent, H. These pendants pass down through slots in the bar, E, and have friction rollers, (*d*),

at their lower ends, one to each; the friction rollers bearing against the cross pieces, (*e*), (*e*) of the carriage, D. To the lower ends of the pendants, H, H, there is attached a pattern, I. This pattern is formed of a metal rod curved or bent, corresponding to the "bilge" intended to be given the staves, see Fig. 2.

J, is a metal plate which is placed transversely in the frame, A, and has a curved slot, (*e*), made through it; said slot forming part of a circle struck from the center of the journals, (*b*), of the bar, E. The pattern, I, passes through the slot, (*e*).

The operation will be readily seen. The stave, K, to be jointed is clamped upon the bed, G, the upper surface of which is perfectly flat so that the stave is not bent in the least. The edges of the stave project beyond the sides of the bar, E, so that the saw, C, may act upon the edges of the stave. As the carriage, D, is shoved along on the frame, A, the slotted plate, J, will tilt or vibrate the bed, the front end of which will be depressed at the commencement of the operation; the plate, J, gradually raising it to an elevated position; the front end of the bed being elevated to its extreme height at the completion of the forward stroke of the carriage, D. This tilting of the bed gives the proper bilge to the stave, as the bed and stave, being necessarily at one side of the saw, is placed obliquely with the plane of the rotation of the saw, and the ends of the staves will be thrown across the saw, so that the edges of the stave will be cut taper from its center. When one edge of the stave is sawed the bed, G, is placed at the opposite side of the saw by turning the bar, E, and the opposite edge of the stave is sawed.

I do not confine myself to the precise arrangement of the pattern, I, as shown in Figs. 1 and 2, for that may be raised or modified as shown in Figs. 3 and 4, where the bar, E, is grooved on one side, as shown at (*f*); the groove corresponding in shape with the pattern, I; the bed, G, having a screw, (*g*), passing through it into the groove. This arrangement is an equivalent of that shown in Figs. 1 and 2.

The above invention is simple and operates well. It may be economically constructed, is not liable to get out of repair

and may be operated or attended by any one with little practice.

Having thus described my invention, what I claim as new and desire to secure  
5 by Letters Patent, is—

The vibrating or tilting bed, G, fitted or pivoted to a bar, E, within the carriage, D,

as shown, the bed being operated by the pattern, I, or its equivalent; substantially as shown, for the purpose specified.

J. K. DERBY.

Witnesses:

GEO. A. DOM,  
S. S. DERBY.