

W. A. RIFE.  
Straw-Cutter.

No. 209,515.

Patented Oct. 29, 1878.

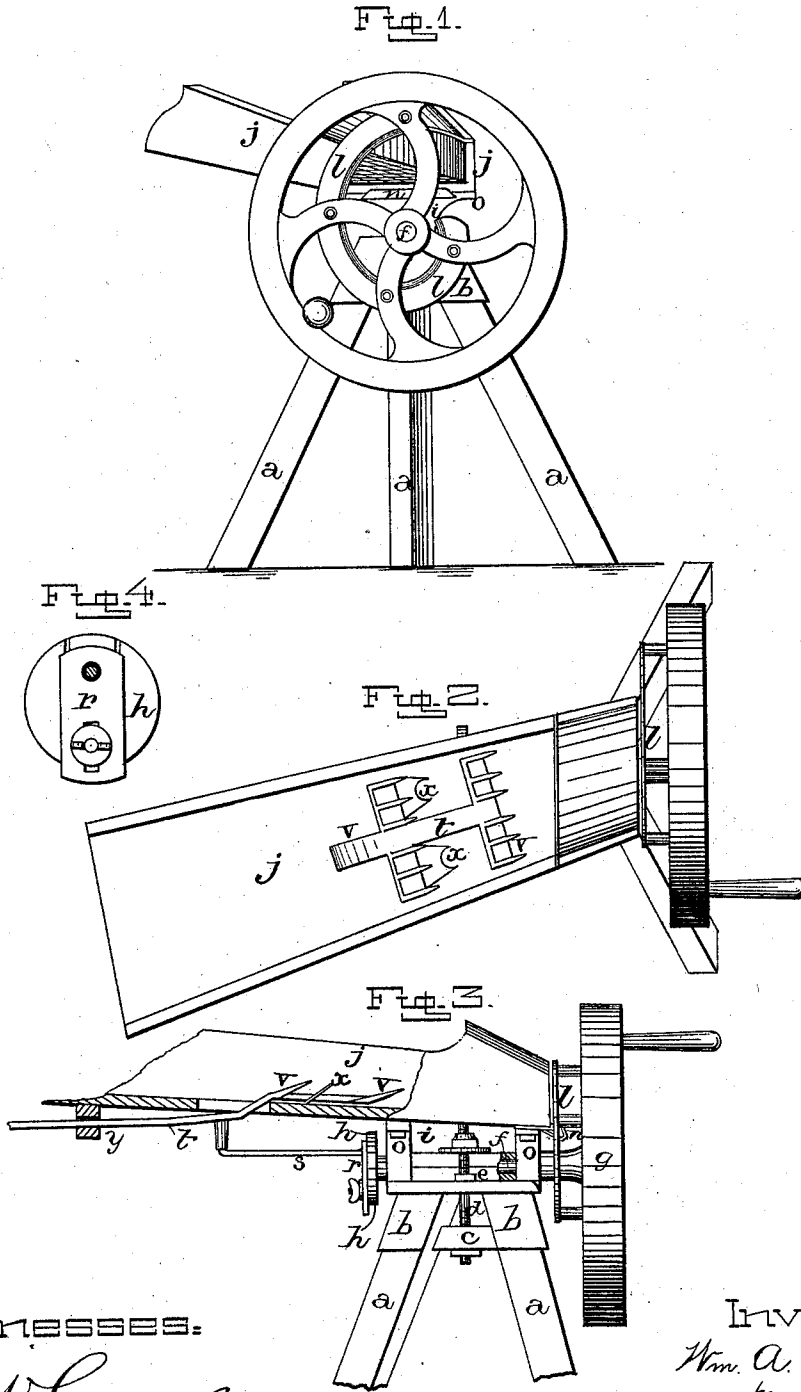

Witnesses:

*J. W. Garner*  
*H. S. D. Haines*

Inventor:  
*Wm. A. Rife,*  
per  
*F. A. Lehmann, Atty*

# UNITED STATES PATENT OFFICE.

WILLIAM A. RIFE, OF VALLEY MILLS, VIRGINIA.

## IMPROVEMENT IN STRAW-CUTTERS.

Specification forming part of Letters Patent No. 209,515, dated October 29, 1878; application filed October 8, 1878.

*To all whom it may concern:*

Be it known that I, WILLIAM A. RIFE, of Valley Mills, in the county of Augusta and State of Virginia, have invented certain new and useful Improvements in Feed-Cutters; and I do hereby declare the following to be a full, clear, and exact description of the invention, such as will enable others skilled in the art to which it pertains to make and use it, reference being had to the accompanying drawings, which form part of this specification.

My invention relates to an improvement in feed-cutters; and it consists in the arrangement and combination of parts, whereby a simple, cheap, and effective machine is produced, as will be more fully described hereinafter.

Figure 1 is a front view of my cutter. Fig. 2 is a plan view of the same. Fig. 3 is a side elevation, partly in section; Fig. 4, a detail view.

*a* represents the legs, which have their upper ends inclined toward each other, and rigidly held in position by the casting *b*, which fits over their tops, and the spider *c*, which holds the ends equidistant from each other.

Passing up through the two parts *b c* is a screw-bolt, *d*, down over which is passed a nut, *e*, for the purpose of securing these two parts rigidly together, while the upper part of the machine is removed.

Upon the top of the casting *b* is formed the lower half of box for the shaft *f*, upon the front end of which shaft is secured the cutter-wheel *g*, and upon the rear end the disk *h*.

The upper half of the box for the shaft is formed in the casting *i*, which is provided with arms or supports *o*, for supporting the cutting-box *j*, and held rigidly down upon the top of the casting *b* by means of suitable bolts and nuts, or by any other means.

The box *j*, instead of being in a line with the shaft *f*, is placed at an angle thereto, as shown in Fig. 2, for the purpose of enabling the feed mechanism to be operated by the rear end of the shaft.

The knife *l* is secured to the inner side of the wheel *g* by suitable bolts, and is made removable, so that it can be sharpened whenever it becomes dull. This knife forms a flat spiral, having its heel secured close to the shaft

*f*, while its outer end projects outward to the inside rim of the wheel, and is sharpened upon its inner edge.

As the wheel *g* sweeps around the outer end of the knife simply gathers the straw for a cut as it projects beyond the end of the box, and then the more curved part of the knife begins to give a rapid sliding cut, which is kept up until the rear end of the knife begins to rise up over the lower front edge of the box.

Secured by means of a bent arm to the front end of the box is the support *n* for the end of the straw, and between this support and the end of the box the heel of the blade passes without the slightest hinderance, thus insuring that the straw will always be cut. Owing to the shape of the knife, as here shown, but a single one is needed upon the wheel, and the straw can be cut with much greater ease than with the usual form of knife.

Secured to the disk *h* on the rear end of the shaft *f* is a slotted adjustable plate, *r*, through one end of which the connecting-rod *s* passes.

As the plate *r* is clamped in place by a set-screw, so that it cannot be moved endwise, and as the edges of the plate are held in grooves in the disk, so that it cannot move sidewise, it will be seen that as the disk is turned around by the shaft the lower end of the rod *s* is moved back and forth and up and down. The upper end of this rod *s* is turned upward, and passed through the device *t*, which feeds the hay and straw constantly forward toward the cutting-knife. This device *t* has two extensions, *v*, projecting outward from its edges, which extensions are armed with sharp teeth for pushing the hay and straw forward.

Secured in the bottom of the box between the extensions are the sharp prongs *x*, which prevent the hay and straw from being drawn backward by the extensions as they move back for another hold. The rear end of the device *t* plays idly through a keeper, *y*.

As the rod *s* communicates its motion to the device *t* at each revolution of the disk, the front end of the device *t* rises upward and forward, and feeds the hay and straw forward to the cutter, and then sinks downward and moves back for another hold. This forward movement of the straw only takes place after the

knife has ceased to cut, and not while the cutting is being done, for while the knife is cutting the device *t* is moving backward.

As the plate *r* is slotted, it can be adjusted back and forth on the disk, and thus increase and decrease the length of feed.

Having thus described my invention, I claim—

1. The frame of the straw-cutter, consisting, essentially, of the legs *a*, castings *b* *i*, spider *c*, and connecting-bolts, the box for the shaft *f* being made in the two castings, all constructed as shown.

2. The combination of the shaft *f*, box *j*, and the feed mechanism, the feed being connected to the end of the shaft, all arranged substantially as set forth.

3. The combination of the shaft *f*, disk *h*, plate *r*, connecting-rod, and the feeding device, substantially as described.

4. The feed device *t*, having the pronged extensions *v*, fixed prongs *x*, and an operating mechanism, the parts being arranged and combined substantially as specified.

In testimony that I claim the foregoing I have hereunto set my hand this 8th day of October, 1878.

WILLIAM A. RIFE.

Witnesses:

ROBERT M. BARR,  
H. A. HALL.