

June 17, 1969

D. C. HOLLOWAY

3,450,185

ACOUSTICAL OPERABLE PANEL ARRANGEMENT WITH REMOVABLE PANEL COVERS

Filed Feb. 10, 1967

Sheet 1 of 4

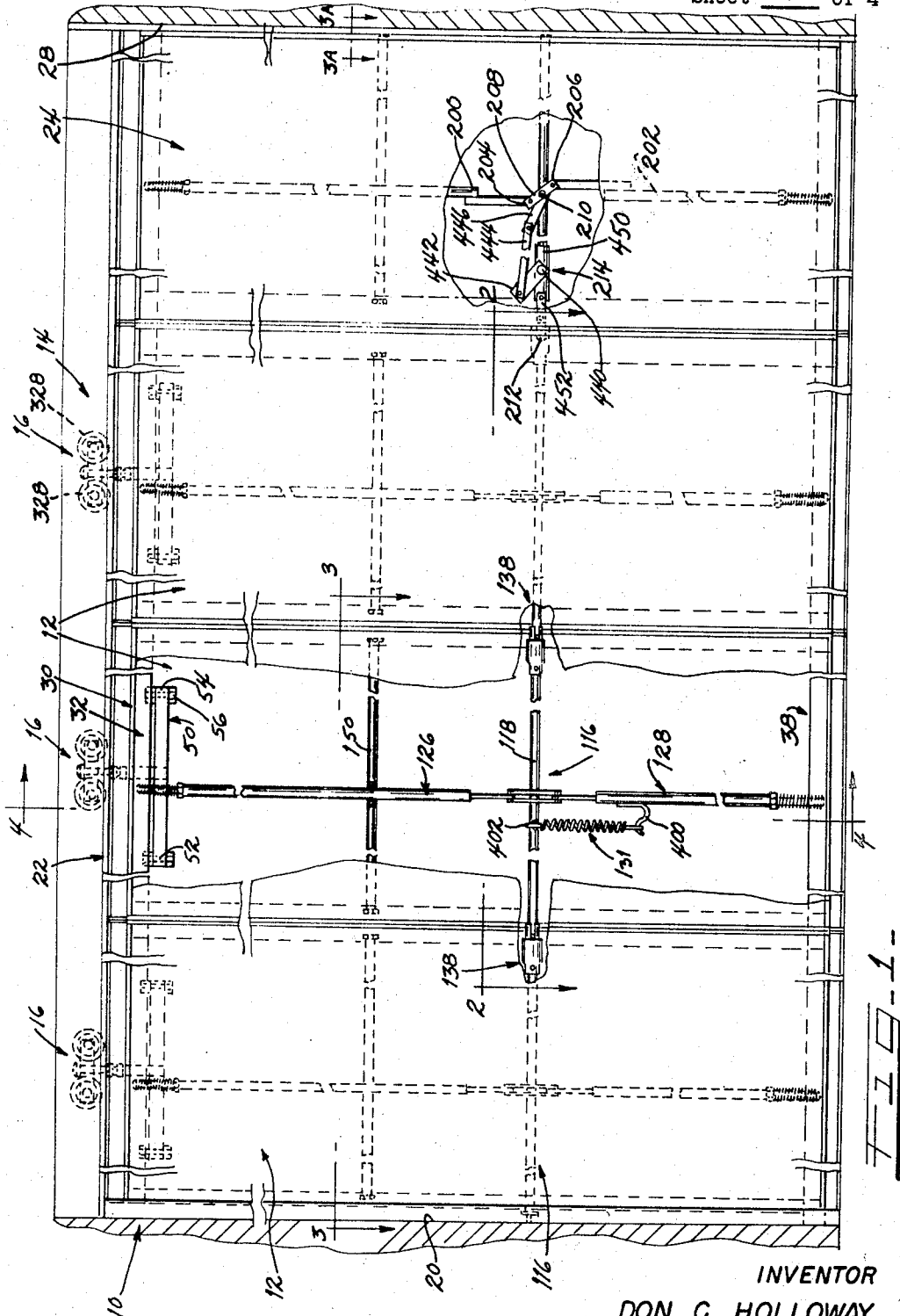

INVENTOR  
DON C. HOLLOWAY  
BY *Mann, Broton, & Williams*  
ATT'Y.

June 17, 1969

D. C. HOLLOWAY

3,450,185

ACOUSTICAL OPERABLE PANEL ARRANGEMENT WITH REMOVABLE PANEL COVERS

Filed Feb. 10, 1967

Sheet 2 of 4

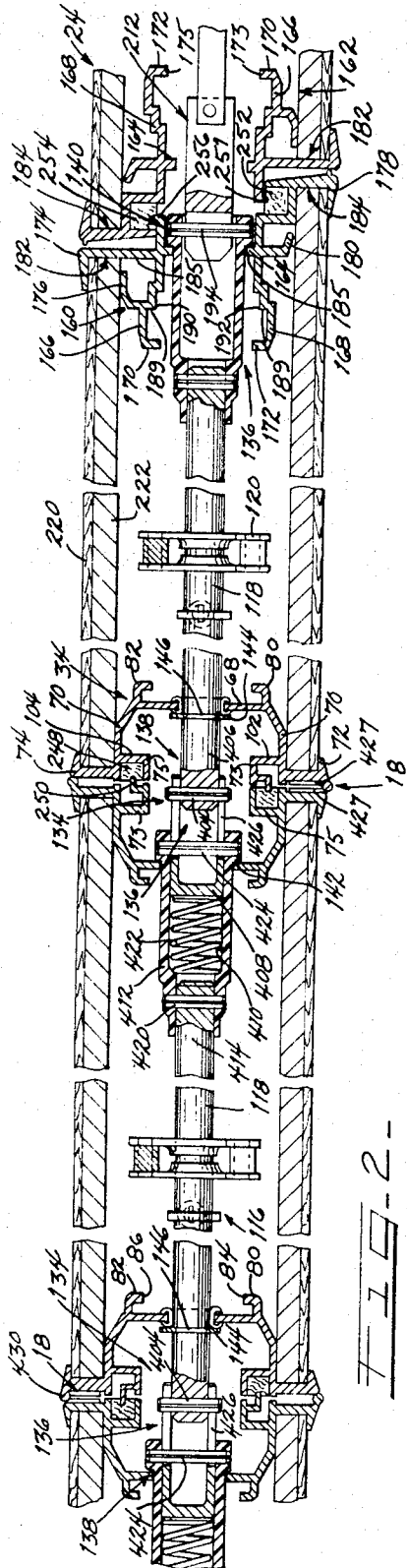

FIG. 2

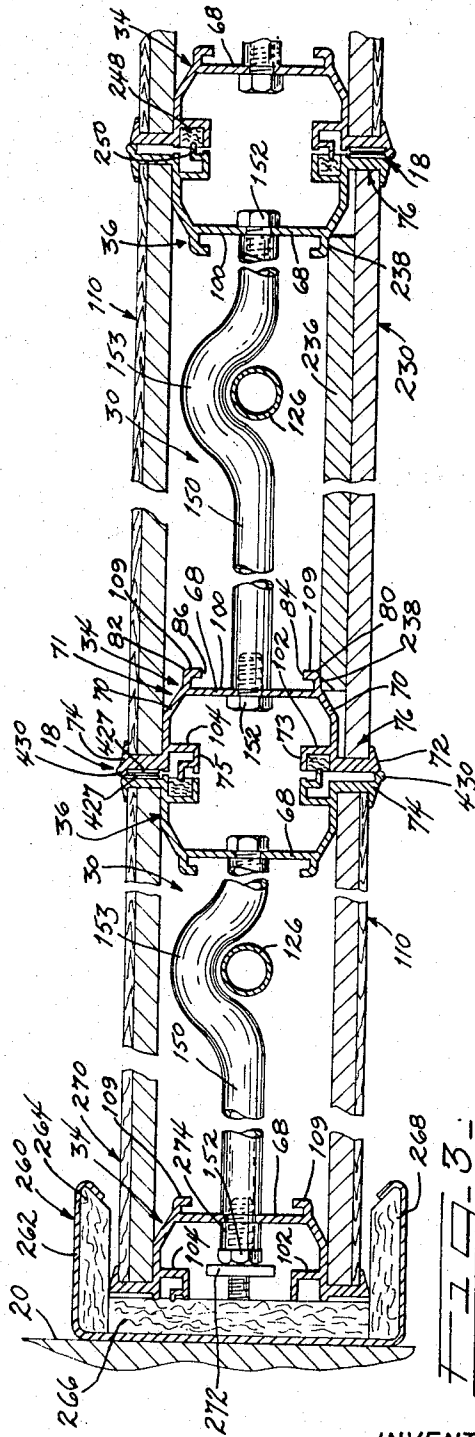

FIG. 3

INVENTOR  
 DON C. HOLLOWAY  
 BY *Wann, Brown, M. Williams*  
 ATT'Y.

June 17, 1969

D. C. HOLLOWAY

3,450,185

ACOUSTICAL OPERABLE PANEL ARRANGEMENT WITH REMOVABLE PANEL COVERS

Filed Feb. 10, 1967

Sheet 3 of 4

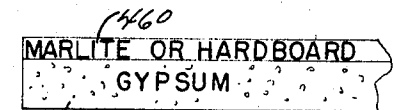
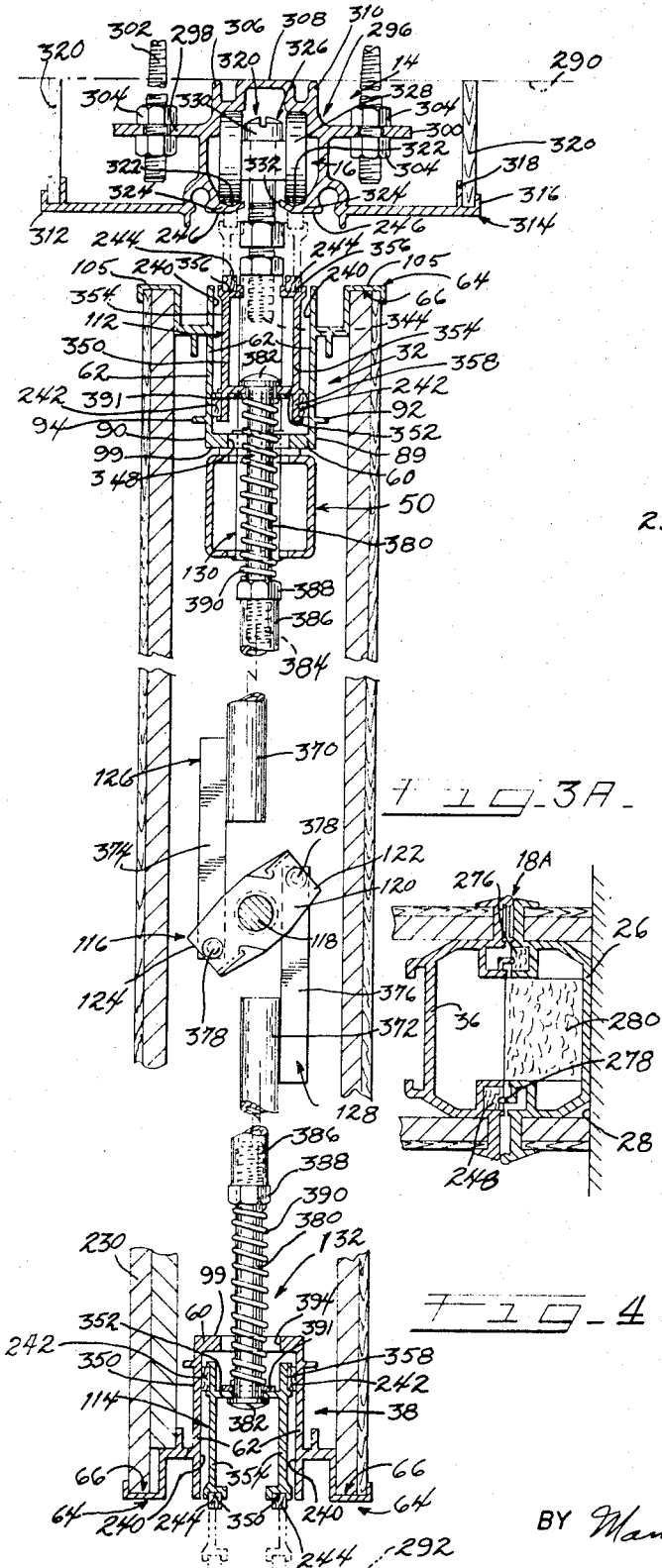

5

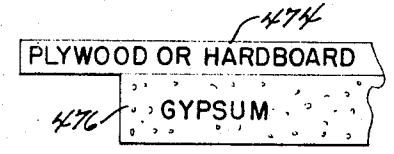

6

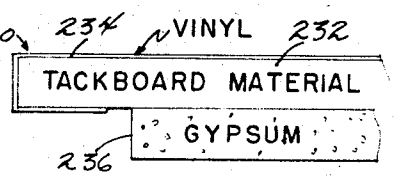

7



3A

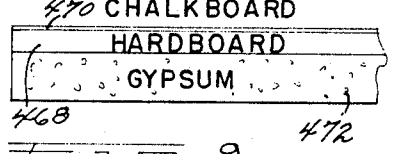

8



9

INVENTOR  
 DON C. HOLLOWAY  
 BY *Mann, Brown, M. Williams*  
 ATT'Y.

June 17, 1969

D. C. HOLLOWAY

3,450,185

ACOUSTICAL OPERABLE PANEL ARRANGEMENT WITH REMOVABLE PANEL COVERS

Filed Feb. 10, 1967

Sheet 4 of 4

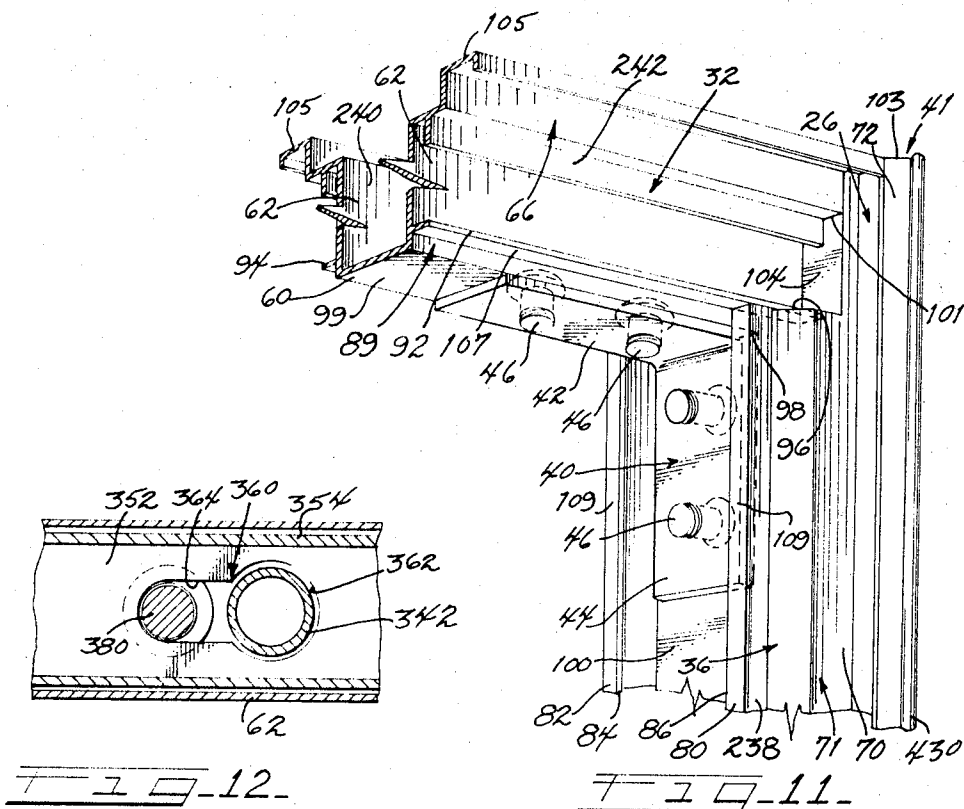
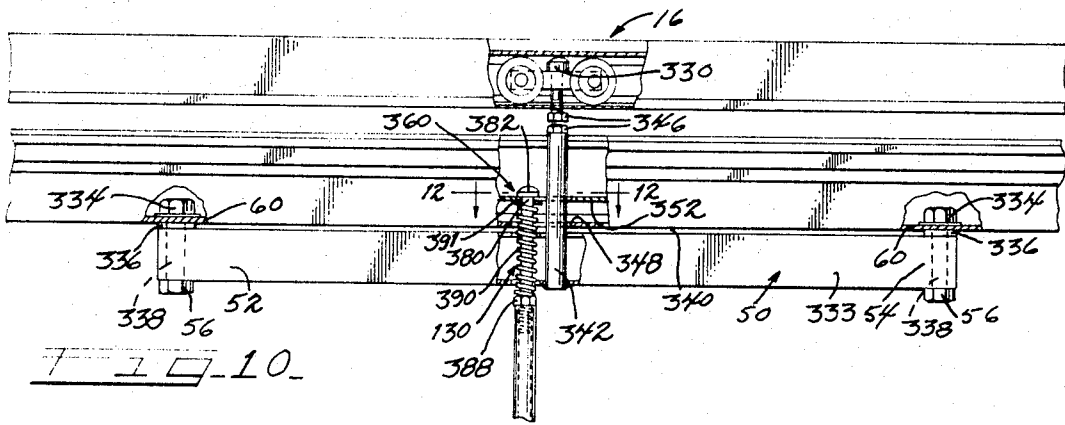

INVENTOR  
DON C. HOLLOWAY  
BY *Mann, Broton, M. Williams*  
ATT'Y.

1

2

3,450,185  
**ACOUSTICAL OPERABLE PANEL ARRANGEMENT  
WITH REMOVABLE PANEL COVERS**

Don C. Holloway, Janesville, Wis., assignor to  
Hough Manufacturing Corporation, a corporation  
of Connecticut

Filed Feb. 10, 1967, Ser. No. 615,204

Int. Cl. E05d 15/26

U.S. Cl. 160—199

8 Claims

**ABSTRACT OF THE DISCLOSURE**

This invention has to do with operable panel type room partitions and is concerned with a special panel frame construction that provides a simplified frame structural arrangement which permits the panel covers to be readily replaced or changed. The individual panel frames are made up of top, bottom, and side frame members formed from extruded sections of aluminum or the like, which interfit at the corners of the frame and are detachably secured together at such corners by angle members which are arranged to permit either side member to be readily removed from the frame so as to provide for changing of the covers on either side of the panel. The frame members about either face of the panel defines special cover receiving recesses that, when a frame is assembled, are disposed in circumambient relation about each panel face and are formed to mount the covers in physical isolation from each other except at their edges and receive several different alternate types of covers designed for sound transmission inhibiting effects. The individual panels include upper and lower retractable seals for securing the panel in place between a ceiling track and the room floor, and the panels are individually supported by their own roller supporting devices from which the frames are respectively suspended through a novel top frame member load transmitting device. The panel arrangement also includes novel frame member sectioning configurations for top sound inhibiting results and a pass door arrangement that includes the simplified features of the basic panel frame.

Heretofore frames for operable panel type partitions have been made from solid framing elements with each having its own special shape and with the frame members being permanently secured together in a way to appropriately resist the load supplied thereto through gravity and the like as a result of their being suspended from a ceiling supported trackway or the like.

Furthermore, in conventional arrangements, the panel cover is permanently secured in place and when a change in decor or damage to the cover occurs, it is necessary to replace the entire panel to remedy the situation.

A principal object of this invention is to provide a panel arrangement having a simplified framing arrangement which permits ready removal and replacement of the panel covers.

Another principal object of the invention is to provide a special panel frame arrangement designed for ready removal of the frame side members for replacing panel covers, and which permits the selection of several alternate type cover arrangements of varying thicknesses and acoustical or other desired properties.

Still other objects of the invention are to provide a novel arrangement for suspending a panel frame from its roller carrier, to provide standard frame members that are suitable for any panel arrangement including a pass door and require only four basic extrusions for the frame members, to provide panel frame members that are spe-

cifically designed to block all possible sound passageways between either side of the panel, and to support the panel covers in such manner that they are isolated from each other except at their edges for maximum sound transmission loss characteristics, and to provide a panel arrangement that is economical of manufacture, convenient to install and use, and readily adapted for application to a wide variety of installation conditions.

Other objects, uses, and advantages will be obvious or become apparent from a consideration of the following detailed description and the application drawings.

In the drawings:

FIGURE 1 is an elevational view of a preferred embodiment of the invention showing a three panel arrangement with a pass door, and with the panels and door in their closed or partition forming positions;

FIGURE 2 is a horizontal sectional view substantially along line 2—2 of FIGURE 1;

FIGURE 3 is a horizontal cross-sectional view taken substantially along line 3—3 of FIGURE 1;

FIGURE 3A is a view similar to that of FIGURE 3 but showing the hinged edge of the pass door, it being a section along line 3A—3A of FIGURE 1;

FIGURE 4 is a vertical cross-sectional view through one of the panel members and taken substantially along line 4—4 of FIGURE 1;

FIGURES 5—9 illustrate several alternate cover arrangements that may be employed in connection with the panels of this invention;

FIGURE 10 is a fragmental elevational view of one of the panel top frame members and roller support therefor;

FIGURE 11 is a fragmental perspective view illustrating a typical corner joint for the panel frames, in this instance showing the top frame member secured to a side frame member; and

FIGURE 12 is a cross-sectional view taken substantially along line 12—12 of FIGURE 10.

However, it is to be distinctly understood that the specific drawing illustrations provided are supplied primarily to comply with the requirements of the Patent Code and that the invention may have other specific embodiments that will be obvious to those skilled in the art.

*General description*

Reference numeral 10 of FIGURE 1 generally indicates a preferred embodiment of the invention in which the operable panel arrangement 10 comprises a plurality of panels 12 suspended from a trackway 14 by roller type carrier units 16 and hinged at alternate side edges as at 18 to swing between the wall forming positions shown in FIGURE 1 and a wall folded position in which the panels 12 are disposed in side by side position adjacent the room wall 20 or the like at one side of the space 22 which is to be partitioned by the operable panel arrangement 10.

Associated with the panels 12 is a pass door 24 of a construction similar to the panels 12 and hinged as at 18A to a pass door post 26 that is affixed in any suitable manner to the wall 28 at the other side of the room being partitioned.

As indicated in FIGURES 1—4, each panel 12 comprises a frame 30 formed of a top member 32, spaced side members 34 and 36, and a bottom member 38, with the top, bottom and side members being formed from extruded lengths of aluminum or the like having the configurations indicated in FIGURES 2, 3, 4 and 11.

In accordance with this invention, the side members 34 and 36 are secured to the respective top members 32 and 38 by angle members 40 having their respective arms 42 and 44 secured to the respective frame members by

appropriate cap screws having their heads disposed exteriorly of frame 30.

The individual frames 30 made up by the members 32, 34, 36 and 38 secured together in the manner indicated are suspended from their carrier 16 by having the frames connected to the carrier 16 through an elongate load transmission member 50 that has a length on the order of one-half the width of the respective panels 12 and is secured at its ends 52 and 54 to the frame top member 32 by bolts 56.

As indicated in FIGURE 4, the top and bottom frame members 32 and 38 are identical but inverted (and are thus interchangeable) and each is in the form of a channel shaped configuration including a base portion 89 defined by a central web portion 60 and spaced vertically disposed side flange portions 62 each formed with an appendage or extension structure 64 defining a cover edge receiving recess 66.

As indicated in FIGURES 2 and 3, the side frame members 34 and 36 are of identical generally channel shaped configuration including a base portion 71 defined by a central web portion 68 extending between spaced flange portions 70 that are provided with laterally extending outwardly projecting extensions 72 and 74, each of which defines a channel shaped recess 76 to receive the cover edge, and inwardly disposed extensions 73 and 75 one of which defines a seal receiving recess and the other of which defines a seal compressing finger.

The top, bottom and side frame members of the respective frames 30 are proportioned such that the side frame members interfit at the frame corners 41 for firm bracing relation therebetween. Thus, the side frame members 34 and 36 include angle shaped projections 80 and 82 ending in faces 84 and 86, respectively that are proportioned to engage the side faces 88 and 90 of the top and bottom frame member bases 60.

The flange portion 62 of the top and bottom frame members 32 and 38 each include laterally projecting ledge portions 92 and 94 that are adapted to be engaged by a shoulder 96 formed in the base portion 71 of the respective side members 34 and 36 to form corners 41, and for this purpose, the base portion 89 of the top and bottom frame members 32 and 38 is cutaway sufficiently so that its resulting foreshortened edge 98 will abut the respective side member web surfaces 100 as the ends 101 of the respective members 32 and 38 abut against coplanar abutment surfaces 102 and 104 that are formed on the inwardly facing sides of the appendages or extensions 73 and 75 of the respective side frame members 34 and 36. Edge 98 of members 32 and 38 is formed by excising base 89 from ends 101 up to the ledge portions 92 and 94 an amount equivalent to the distance between the planes of surfaces 100 and 102 (or 104), and shoulder 96 is formed by excising side member base portion 71 from the end 103 of the side member a dimension equivalent to the distance between the planes of surfaces 105 thereof and the surface 107 of ledge portions 92 and 94 thereof a depth laterally of the members 34 and 36 equivalent to the distance between the planes of surfaces 102 and 104 thereof and the surfaces 109 of projections 80 and 82.

As indicated in FIGURES 2-4 and 11, the top, bottom and side frame members of the respective frames 30 are secured together so that their cover edge receiving recesses 66 and 76 are in coplanar relation to receive the respective covers 110 or their alternates of FIGURES 5-9, and the arms 42 and 44 of the angle members 40 engage inner surface 99 of members 32 and 38 and surface 100 of members 34 and 36.

As is also indicated in FIGURE 11, the top and bottom frame members 32 and 38 are braced against the shoulders 96 of the side frame members by the locating action of ledges 92 and 94 of the top and bottom frame members 32 and 38, respectively.

Each frame 30 carries within the flange portions 62 of the respective top and bottom frame members 32 and 38 the respective upper and lower seal members 112 and 114, which move between the extended and retracted positions indicated in FIGURE 4 under the control of the actuating mechanism 116 that is mounted within each frame 30 in the form of a rod or shaft 118 journaled between the web portions 68 of the frame side members 34 and 36 and having a double ended swing arm structure 120 fixed thereto of which the respective ends 122 and 124 are connected to the respective rod structures 126 and 128 that are in turn resiliently connected to the respective seal members 112 and 114 through the resilient connections 130 and 132 that are indicated in FIGURE 4 and which extend through the respective top and bottom frame members 32 and 38 and in the case of the top frame member through the load transmitting member 50 (see FIGURE 4).

In accordance with the teachings of Douglass Patent 3,295,257, the rods or shafts 118 of each panel have a male coupling member 134 at one end thereof and a female coupling member 136 at the other end thereof which are adapted to couple with their counterparts of adjacent panels when the panels are swung to their wall forming positions of FIGURES 1-3, and to uncouple when the panels are swung to their wall folded positions. In the wall forming positions, the coupling members 134 and 136 form coupling devices 138 which permit all the seal members to be simultaneously extended or retracted from the end female coupling member 136 at the pass door where indicated at 140 in FIGURE 2.

As also indicated in FIGURE 2, the panel frame side members 34 and 36 are braced laterally thereof by being interposed between a shoulder 142 of the respective coupling members 136 and a locking ring 144 applied to annular recesses 146 formed in the respective rods 118. For panels of moderate height this reinforcement laterally of the frame will be adequate, but for panels of greater heights additional reinforcement is provided by rods 150 extending between the web portions 68 of the respective side frame members 34 and 36 and secured in place by bolts 152 (see FIGURE 3), and arced about rods 126 as at 153.

The panel 12 that is to be disposed adjacent the pass door 24 is provided with a special side frame member 160 that cooperates with a similar side frame member 162 of the pass door (see FIGURE 2). These members 160 and 162 are also identical elements formed from extruded aluminum or the like, and as indicated in FIGURE 2, they comprise generally channel shaped members that include a web portion 164 and spaced flange portions 166 and 168 with the latter terminating in opposed edge portions 170 and 172 that are comparable to the projections 80 and 82 of frame side members 34 and 36 and include faces 173 and 175 adapted to engage the base portions 89 of the respective upper and lower frame members 32 and 38.

The members 160 and 162 also each include spaced extensions 174 and 176 on one side thereof and 178 and 180 on the other side thereof that respectively define cover edge receiving recesses 182 and 184 that are disposed in coplanar relation with recesses 66 and 76 of the frame members 32, 34 and 38.

The top and bottom frame members 32 and 38 of the end panel 12 are secured to the special side frame member 160 in the manner similar to that indicated in FIGURE 11, with the top and bottom members 32 and 38 being formed as already indicated (having their bases 89 cut back to edge 98 of FIGURE 11) and with the flange portions 166 and 168 notched at the ends of the respective members 160 and 162 to form a seat or shoulder comparable to shoulder 96 so that the edge 98 of the respective members 32 and 38 will abut against a pair of abutment surfaces 189 defined by shoulders 190 and 192 of the member 160, and the end 101 of the members 32 and

38 will abut against abutment surface 185 of the extension 174. The top and bottom frame members 32 and 38 of the end panel 12 are secured to the special frame member 160 by angle members 40 and their fastening bolts 46 (not shown) in a manner similar to that shown in FIGURE 11, with the angle members being applied between surfaces 99 of the bases 89 of the members 32 and 38 and the surface 185 of base portion 164 of the member 60.

As indicated in FIGURES 1-3, the end panel 12 adjacent the pass door 24 is otherwise the same as the other panels 12 except that the female coupling member 136 of its seal actuating rod 118 is adapted to receive a hand tool cooperating with pin 194 that is fixed thereto to operate the seals.

The pass door frame is arranged similarly to that of the panel frame adjacent it with the special side frame member 162 being applied in the manner already indicated between top and bottom frame members 32 and 38 and a side frame member 36. The pass door is provided with upper and lower seal members 112 and 114 in the same manner as indicated in FIGURE 4 which are actuated by rod structures 200 and 202 that are actuated by being connected to the opposite ends 204 and 206 of a throw arm 208 suitably keyed to shaft 210 journaled within the pass door in any suitable manner, which also actuates the pass door latch dog 212 through a linkage 214. The pass door latch dog 212 in the form shown cooperates with the special coupling member 136 of the panel 12 adjacent it (see FIGURE 2).

The seal operating mechanisms 116 of each frame include a tension spring 131 connected between the respective rods 118 and the composite rods 128 to bias the seals to their retracted positions. The pass door 24 is similarly equipped (not shown).

Further in accordance with this invention, the cover edge receiving grooves of the various frame members 32, 34, 36, 38, 160, and 162 are formed to accommodate covers of several thicknesses and various characteristics to achieve varying acoustical, fireproofing and/or other effects. For instance, the recesses 66, 76, 182 and 184 in the specific arrangement disclosed are formed to receive covers that are one-half inch thick that are of a composite structure formed of an outer hardboard facing 220 having affixed thereto in any suitable manner a gypsum board base 222. This form of cover is assumed to have the hardboard 220 in the form of Masonite. However, alternate cover constructions for application to the recesses 66, 76, 182 and 184 in the manner indicated in FIGURES 2-4 are shown in FIGURES 5, 8 and 9.

Alternately, one of the cover constructions employed in FIGURES 6 and 7 may be employed, as in accordance with this invention, the frame members are provided with elements to brace a thicker cover arrangement, as indicated in FIGURES 3 and 4, wherein the cover arrangement 230 of FIGURE 7 is employed which comprises an outer layer of tackboard material 232, provided with a vinyl outer coating 234, which is affixed to an inner gypsum board layer 236. As indicated in FIGURE 3, the side surfaces 238 of the frame side member projections 80 are spaced to brace the gypsum layer 236, and as indicated in FIGURE 4, the top and bottom members 32 and 38 are formed with ribs 240 defining outwardly facing bracing surfaces 242 for the same purpose.

Further in accordance with this invention, the space within the respective panels and pass door and between the covers 110 and 230 (or the like) is optionally filled with a suitable sound transmission inhibiting substance such as glass wool (not shown to avoid complicating the drawings).

The components making up the respective panels are proportioned so that when the panels are in their wall forming position of FIGURES 1-3, the ends of the seals 112 and 114 of adjacent panels are disposed closely adjacent each other and in practice are provided with foam

end caps that mutually engage in the wall forming position of the panels and are proportioned so that they firmly grip the inner wall surfaces 240 of the top and bottom frame member flange portions 62. As indicated in FIGURE 4, the seals 112 and 114 are provided with seals 242 that engage the respective top and bottom frame member surfaces 240 and seals 244 that respectively engage the undersurface portions 246 of the trackway in the sealing position of the seals 112 and engage the floor 292 in the sealing position of the seals 114 (note the dashed line positions of FIGURE 4).

As indicated in FIGURES 2 and 3, the panel side frame extensions are each provided with a seal indicated at 248 adapted to be engaged by an opposing flange 250 of the adjacent side frame member extensions 73 longitudinally thereof and between the top and bottom frame members to provide an unbroken acoustical seal from the top to the bottom of the panels. At the pass door, the side frame member 160 is provided with a seal 252 which is engaged by a flange 251 of the pass door side frame 162, while the pass door side frame 162 is provided with a seal 254 extending longitudinally thereof that is engaged by a flange 256 of the side member 160; the seals 252 and 254 and flanges 251 and 256 extend the height of the respective side frame members 160 and 162. Seals 242, 244, 248, 252 and 254 should be formed from a closed cell type foam material such as polyurethane foam.

At the wall 20, the end panel 12 adjacent its cooperates with an anchor channel structure 260 in the form of a channel member 262 that may be formed from extruded aluminum or the like and secured to the wall 20 in any suitable manner, and which is lined with sheets 264, 266 and 268 of a closed cell type foam material such as polyurethane foam positioned and proportioned for engagement by the frame member 34 at end 270 of the adjacent panel 12. The channel structure 260 is preferably provided with an adjustable stop 272 adapted to be engaged by the bolt 152 of the end panel 12 that secures its bracing rod 150 in place, though any other suitable abutment may be employed. As shown in FIGURE 3, the screw 152 in question seats against an annular seat 274 for spacing purposes.

Alternately, sheet 266 may be replaced by a side frame member 36 adjustably mounted within a channel shaped member secured to wall 20 for vertical, lateral and lifting adjustment for the purpose of accurate positioning with respect to the rest of the operable panel 10.

The frame member 26 (see FIGURE 3A) that hinges the pass door 24 is a member 34 or 36 with extensions 80 and 82 removed and is provided with a seal 276 that is engaged by a flange 250 of the adjacent pass door side member, which itself is provided with a seal member 248 that is engaged by a flange 278 of the frame member 26. Seal 276 and its cooperating flange 250 and seal 248 and its cooperating flange 278 extend the height of the respective frame members and seal 276 is of the same material as seal 248. Frame member 26 is also provided with a polyurethane foam layer 280 that at the upper and lower ends thereof is engaged by the adjacent end portions of the seals 112 and 114 that are carried by the pass door. Cover segments 110A are applied to the recesses 76 of frame member 26.

Alternately, frame member 26 may be adjustably mounted within a channel shaped frame member secured to wall 28 for vertical, lateral and lifting adjustment for the purpose of accurate positioning with respect to the rest of the operable panel arrangement.

It will therefore be seen that when the operable panel 10 is in its closed position, all possible spaces that might transmit sound from one side of the panel to the other are closed off through seals of the type indicated. Furthermore, the panel covers are secured together only about the edges of the panel frame which results in providing the "double wall effect" which produces the optimum sound transmission loss for the mass involved. The result

is that the operable panel 10 provides a STC rating of 38 without glass wool or the like in the respective panel between its covers, and an STC rating of 43 is provided where glass wool is employed.

Furthermore, the operable panel arrangement 10 provides for ready removal and replacement of the covers that are carried by the respective panels. This may be done by moving the panels to their wall folded or collapsed positions and removing one of the frame side members 34 or 36 by unscrewing the cap screws 46 that are at the side of the frame to separate the side member in question from the angle member 40 it is secured to, so that the covers 110, 230, or the like may be moved horizontally outwardly of the recesses 66, 76, 182 and 184 in which they are disposed and then replaced with a new cover in like manner after which the removed frame side members are replaced and the removed cap screws 46 reapplied.

Moreover, only four basic extrusions are required to form panel frames 30, as frame members 32 and 38 may be formed from one extrusion, members 34 and 36 from the second extrusion, members 160 and 162 from the third extrusion, and seal members 112 and 114 from the fourth extrusion.

#### *Specific description*

The operable panel arrangement 10 may be applied to any building arrangement providing a room defined by space walls 20 and 28, ceiling 290 and floor 292 that is to be partitioned into two rooms or more than two rooms.

The trackway 14 comprises a trackway forming member 296 applied to the ceiling between walls 20 and 28. In the form shown, member 296 comprises a length of extruded aluminum or the like having the configuration indicated including spaced side flanges 298 and 300 and is secured in place as by being applied to threaded studs 302 affixed to the ceiling, with the trackway being held in place on the studs by lock nuts 304. The trackway forming member 296 is formed with abutments 306, 308 and 310 which are placed in abutting relation with the ceiling, and the member 296 at its side edges 312 and 314 is formed with spaced flanges 316 and 318 that respectively receive decorative panel members 320 that screen off the trackway member 296.

The trackway forming member 296 defines a longitudinally extending passage 320 in which are mounted the roller carrier devices 16 which ride on trackways 322 that are defined by flange portions 324 of the member 296.

The carrier devices 16 each comprise a frame 326 journalling two pair of rollers 328 and supporting the respective panels by a bolt 330 passing through the frame and the slot 332 that is defined by the flange members 324.

As already indicated, the frames of the respective panels are secured to their carrier 16 through the special load transmission members 50, which in the form shown comprise tubular elements 333 formed from mild steel or the like and having their ends secured to the respective frame top members by bolts 56 that are held in place by nuts 334 applied thereto on the inside of the top member bases 88. Washers 336 are applied between the ends 338 of the member 50 and the frame top member 32 to insure that the midportion of the member 50 is spaced from the frame member 32 as indicated at 340 to avoid bending frame members 32.

Fixed to the member 50 and extending therethrough as indicated in FIGURE 10 is a tubular suspension member 342 that has its upper end tapped to receive the threaded end 344 of bolt 330 and in the mounted relation of the two may be secured in place by employing suitable lock nuts 346.

As indicated in FIGURES 10 and 12, the tubular member 342 of load transmitting member 50 extends upwardly through an opening 348 formed in the web 60 of the respective frame top members 32 through

which the resilient connecting devices 130 that actuate the respective seals 112 also extend.

The seal members 112 each comprise a channel shaped member 350 defining a web portion 352 and upstanding flange portions 354 that are formed with recesses 356 which receive the respective sealing members or strips 244. The channel member 350 is also formed to define recesses 358 which receive the respective sealing strips 242.

As indicated in FIGURE 12, the web portion 352 of the seal member 350 is formed to define a key hole slot 360 having a larger end 362 and a smaller end 364. The tubular member 342 of load transmitting member 50 extends upwardly through the larger portion 362 while the resilient securing device 130 is applied to the smaller opening portion 364.

The rod structures 126 and 128 of seal actuating devices 116 of each frame comprise upper and lower tubular members 370 and 372 that are connected to throw arms 120 through supplemental arms 374 and 376 that are secured to one side of the respective members 370 and 372 in the manner indicated in FIGURE 4 so that the members 370 and 372 are disposed approximately at the longitudinal center of each panel. The supplemental members 374 and 376 are secured to the throw arm 118 by suitable pins 378. The seal actuating devices 200 and 202 of the pass door are similarly arranged except that the actuating shaft 210 is at right angles to rods 118.

The resilient connecting devices 130 at the upper end of each panel are employed to connect the upper seal members 112 to the upper actuating rods 370 and are in the form of a bolt 380 extending through key hole slot 360 so as to position its head 382 above web 352 of the seal member 350 and disposed in the smaller portion 364 of the key hole slot 60. The head 382 of bolt 380 is larger than key hole slot portion 364 but smaller than key hole slot portion 362.

The threaded end 384 of bolt 380 is received within a threaded end portion 386 of the member 370 and secured in place by a lock nut 388. Compression spring 390 acting between the lock nut 388 and a washer 391 abutting the web portion 352 provides a resilient connection between the actuating rod 370 and its seal member 112 such that when the seal member is moved from the retracted full line position of FIGURE 4 to the extended dashed line position shown in the same figure, the seal member is resiliently biased against surfaces 246 of the trackway forming member 296, but when the seal is withdrawn to its retracted position, the bolt head 382 forms a direct connection to the seal and positively returns it to its retracted position and holds it there under the action of the springs 131.

The resilient connecting devices 130 may be conveniently assembled to the seals 112 by applying the bolt 380 through the larger portion 362 of key hole slot 360 and then sliding it into the smaller portion 364 of the key hole slot before the tubular member 342 of load transmitting member 50 is applied to the key hole portion 362.

It is preferred that the load transmitting members 50 be so applied to the respective frame upper members 32 that the tubular member 342 is located at the longitudinal center line of the panel.

The resilient connecting devices 132 at the lower end of each panel, and both the devices 130 and 132 of the pass door, are arranged in the same manner as the devices 130, as indicated by corresponding reference numerals for panels 12, except, of course, there is no load transmitting member 50 used in association with the lower frame members 38. Likewise, the seals 114 at the lower ends of the panels may be arranged in the same manner as the seals 112 as indicated by corresponding reference numerals. The same extrusions used for making the seal 112 may be employed to make the seal 114 and seals 112 and 114 are interchangeable in nature.



The springs 131 are operably associated with the seal actuating mechanisms 116 by being operably connected between a hook 400 affixed to the seal actuating mechanism or rod 372 and an S hook 402 that has one of its ends received over rod 118. However, other suitable biasing arrangements of an equivalent nature may be employed.

Referring now to the individual coupling members 134 and 138 that operably associate together for simultaneous rotation of the rods 118 when the panels are in their wall forming positions, it will be seen from FIGURE 2 that the male forming member 134 comprises a cross pin 404 fixed to one end 408 of a rod 118 which cooperates with a slotted cup member 408 that is slidably received in a bore 410 of tubular coupling member 412 which is keyed to the end 414 of the adjacent rod 118 by a suitable pin 420. The cup shaped members 408 are biased outwardly of the respective bores 410 by a compression spring 422 and pins 424 carried by the respective members 412 and acting in the slots 426 (that pins 404 of the adjacent rod 118 cooperate with) retain the members 408 within the members 412. The shoulder 142 of the female coupling element 136 is defined by the outside configuration of tubular member 412.

As indicated in FIGURES 2, 3 and 11, the extensions 74 of the frame members 34 and 36 are formed with a beaded edge 430 which is provided for purposes of camouflaging the hinged knuckles of hinges 18. In applying the hinges 18 the beaded edges 430 are cut away the length of the respective hinges 18 and the leaves 427 of the hinges 18 are secured in place to position their aligned hinged knuckles and connecting pin therefor (not shown) in alignment with the beaded edge 430.

The latch bar dog 212 of the pass door is actuated by applying a suitable handle to shaft 440, which handle also operates to extend and retract the seals 112 and 114 of the pass door. In the diagrammatic showing of FIGURE 1, this mechanism is shown with the seals in their extended position and the latch bar in its locking position and the seals are retracted by rotating the shaft 440 in a clockwise direction to throw the linkage 214 lever 446 which is fixed to the shaft 210 through a link 444 that is pivotally connected to same and lever 442 which is keyed to the shaft 440. This motion also actuates lever 450 that is keyed to shaft 440 to move same in a clockwise direction and draw the latch bar 212 to the right of FIGURE 2 through a link 452 that is pivotally connected between the lever 450 and the latch bar 212. Extension of the seals and locking of the latch door is accomplished by movement in the other direction and the latch bar may be conveniently locked in place by employing a lock and key mechanism which fixes the lever 442 against rotation when it is positioned as shown in FIGURE 1.

Referring now to the alternate covers of FIGURES 5-9, in the alternate form of FIGURE 5 the cover has a thickness of one-half an inch for application into the recesses 66, 76, 182 and 184 comprising a one-eighth inch thick hardboard layer 460 of the type having a baked finish on its outer surface (an example of which is the product sold under the trade name Marlite) fixed to a three-eighths inch thick gypsum board 462. Other cover arrangements having the same thickness dimension are shown in FIGURES 8 and 9, and as shown in FIGURE 8, the cover may comprise a gypsum board 464 having a vinyl covering 466 of appropriate aesthetic appearance, or as indicated in FIGURE 9, the cover may comprise a hardboard sheet 468 having a chalkboard facing 470 (for an overall thickness of one-eighth of an inch) to which is secured a three-eighths inch gypsum board 472.

The cover form of FIGURE 6 is an alternate to that shown in FIGURE 7 for applications where a thicker cover is desired and comprises a plywood or hardboard facing 474 of one-quarter inch thickness to which is applied a gypsum board 476 of one-half inch thickness. In the embodiment of FIGURE 7, the tackboard 332 and its cover

334 would have an overall thickness of three-eighths of an inch while the gypsum board 236 has a thickness of three-eighths of an inch for a total cover thickness of three-quarters of an inch except about the rim of the cover that is thus reduced in thickness for application into the respective recesses 66, 76, 182 and 184.

I claim:

1. In an operable panel type partition arrangement including an overhead trackway, and a plurality of at least two panels each having opposed faces and hinged together in side-by-side relation for movement between wall forming and wall folded positions, an overhead trackway defining the path of movement of the panels between their said positions, and carrier means riding along said trackway and supporting the respective panels for suspending the respective panels for movement between said positions, the improvement wherein said panels each comprise:

a frame comprising top and bottom members disposed in substantially parallel horizontal relation and spaced side members disposed in substantially parallel vertical relation with their ends positioned in juxtaposed relation with the ends of the respective top and bottom member,

means for releasably securing the ends of the respective side frame members to the ends of the respective top and bottom members adjacent same including means for releasing said securing means at said ends of one of said side members and for separating said one side member from the adjacent ends of said top and bottom members by moving same away therefrom in the plane of the panel defined by said members, said frame members each being formed to define in the secured relation thereof cover edge receiving recesses aligned in circumambient coplanar relation about the respective faces of the respective panels and defining a mounting recess structure,

a cover received in each of said mounting recess structures of the respective panels and being proportioned to be slidably removed therefrom on movement in the plane thereof on separation of said one side member from said frame, said recesses being formed to preclude movement of said covers normal to their respective planes, said covers being secured to the respective panels by having their edges received in the respective mounting recess structures with said one side member secured to said frame by said securing means, and said covers of each panel being isolated from each other except at said recess structure for maximum sound loss characteristics,

whereby the covers of the respective panels may be replaced without removing the respective panels from the partition by positioning said panels in their wall folded position and separating said one side member thereof from the top and bottom members thereof to open the respective mounting recess structures for removal and replacement of the respective covers by sliding same horizontally in the planes thereof relative to said frames.

2. The improvement set forth in claim 1 wherein: said frame members are of generally channel shaped transverse cross-sectional configuration, with each frame member defining in transverse section a web portion having spaced flange portions projecting laterally thereof from the longitudinally extending edges of the web portion, with the web and flange portions of said members at their respective juxtaposed ends being in interfitting bracing relation and defining interlocking corner portions, said securing means comprising an arm member at each of said corner portions secured to the frame top and bottom members respectively and being in abutting

11

relation with the inwardly facing sides of the respective frame side member web portions, and screw means operable from the outwardly facing sides of the frame respective side member web portions for making the respective arms fast to the respective frame side members.

3. The improvement set forth in claim 1 wherein each of said panels further includes:  
 an elongate load transmission member positioned adjacent to the panel top frame member and beneath same in parallel relation therewith,  
 said load transmission member having a length that is at least on the order of one half the length of said top frame member and having its ends secured to said top frame member,  
 said load transmission member being spaced from said top frame member intermediate its ends,  
 with the carrier means of the panel being secured to said load transmission member midway between the ends of said top member,  
 whereby the weight of said panel is supported at spaced points along said top member thereof positioned to avoid bending same.

4. The improvement set forth in claim 2 including:  
 means for tying said side members together,  
 said tying means comprising:  
 a rod member extending between the web portions of the respective side frame members,  
 said rod member being parallel to said top and bottom frame members,  
 and means for releasably coupling the ends of said rod member to the respective side member web portions.

5. The improvement set forth in claim 3 wherein said panels each further comprise:  
 the flange portions of said top and bottom frame members projecting outwardly of said frame of the respective panels in the plane thereof,  
 and including a grip member mounted within the flange portions of the respective top and bottom members for shifting movement outwardly and inwardly of said frame in the plane thereof between retracted and extended positions,  
 and means for simultaneously moving said grip members of the respective panels from their retracted positions to their extended positions and comprising swing arm means mounted within the respective

12

panels for swinging movement in a vertical plane and rod means secured between the respective grip members and said swing arm means,  
 said top frame member grip member having a key hole slot formed therein,  
 with the carrier means of the respective panels being secured to said load transmitting member through one portion of said slot and the rod means of said top frame member grip member being secured thereto through the other portion of said slot,  
 said one portion of said slot being wider than the other portion thereof and said rod means being proportioned to fit through said slot one portion for application to said top frame member grip member and to operate in said slot other portion,  
 said rod means including a head portion proportioned to oppose withdrawal of same through said slot other portion.

6. The improvement set forth in claim 1 wherein: said frame member recesses are proportioned to alternately receive covers of several different thicknesses.

7. The improvements set forth in claim 1 wherein the space between said covers is filled with glass wool.

8. The improvement set forth in claim 1 wherein: said frame top and bottom members are extruded elements formed from the same extrusion, and wherein said frame side members are extruded elements formed from the same extrusion.

References Cited

UNITED STATES PATENTS

1,171,138	2/1916	Quagliano	160—381 X
3,073,381	1/1963	Burmeister	160—40
3,195,192	7/1965	Neisewander	160—40 X
3,241,197	3/1966	Gogerty	49—127 X
3,253,552	4/1966	Stein	160—40 X
3,277,952	10/1966	Tsuahako	160—199
3,295,257	1/1967	Douglass	160—40 X
3,295,588	1/1967	Gilson	160—199
3,300,899	1/1967	Haws et al.	49—127
3,309,816	3/1967	Malone	49—127

DENNIS L. TAYLOR, Primary Examiner.

U.S. Cl. X.R.

160—206