

(19)  
(12)

(KR)  
(B1)

(51) 。 Int. Cl. <sup>6</sup>  
B66B 5/28  
B66B 1/00

(45)  
(11)  
(24)

2002 01 09  
10 - 0319936  
2001 12 22

---

(21) 10 - 1999 - 0007141  
(22) 1999 03 04

(65) 2000 - 0059499  
(43) 2000 10 05

---

(73)

946 - 1

(72)

987 1901

(74)

:

---

(54)

---

;

;



(4) (5)가 , (5) (3) (6) (6)  
 (7) (3) (6)  
 (1) (5) (1) (2) (1) (4) 2  
 (9) (8)가 , (9) (5)  
 (9A) , (10) (1) (4) (1)  
 (4) (11) (9)가 (11A)  
 (11A) (9) (12)

(1) (5) (5) (1)가 , (1)가 (1)  
 가 (4) (4) (5) (5) 가  
 (1)가 (1)가 (6) 가  
 (4) 가 , (1)가 (1) 가 가  
 (6) (1) 가

가 가 가

, ; ; ;  
 가 . ,

3 , 5 가 가 , 4 ( (9) (11) (11A) , (9A) (10)가 (13) (9) (12) , (12) 4

(11) (12) (14) (14) (14A)  
 (14B) , (14B) (14C)가 ,  
 (15)(15A)가 (1) (16) , (16)  
 (1) (14) (14B)  
 (17) , (17) (14)  
 (18)가 (14C)  
 '+' '-' 가 '+' '-' , 가 (引力)  
 , 가 가 (14)

(4) (16) (17) (1)  
 (14) 가 (14B)  
 (14) , (1)  
 (1) (5) (1) (14) (6)  
 (1) (1) (1)가  
 (4) (14) 가 (9) (12) 가  
 (1) (1) (9) (12) (1) (1)  
 (6) (1) (12) 5 (9)  
 , 5 (1)  
 (12) (1) (9)

(57)

1.

,  
 ; ; ;

2.

1 , ,

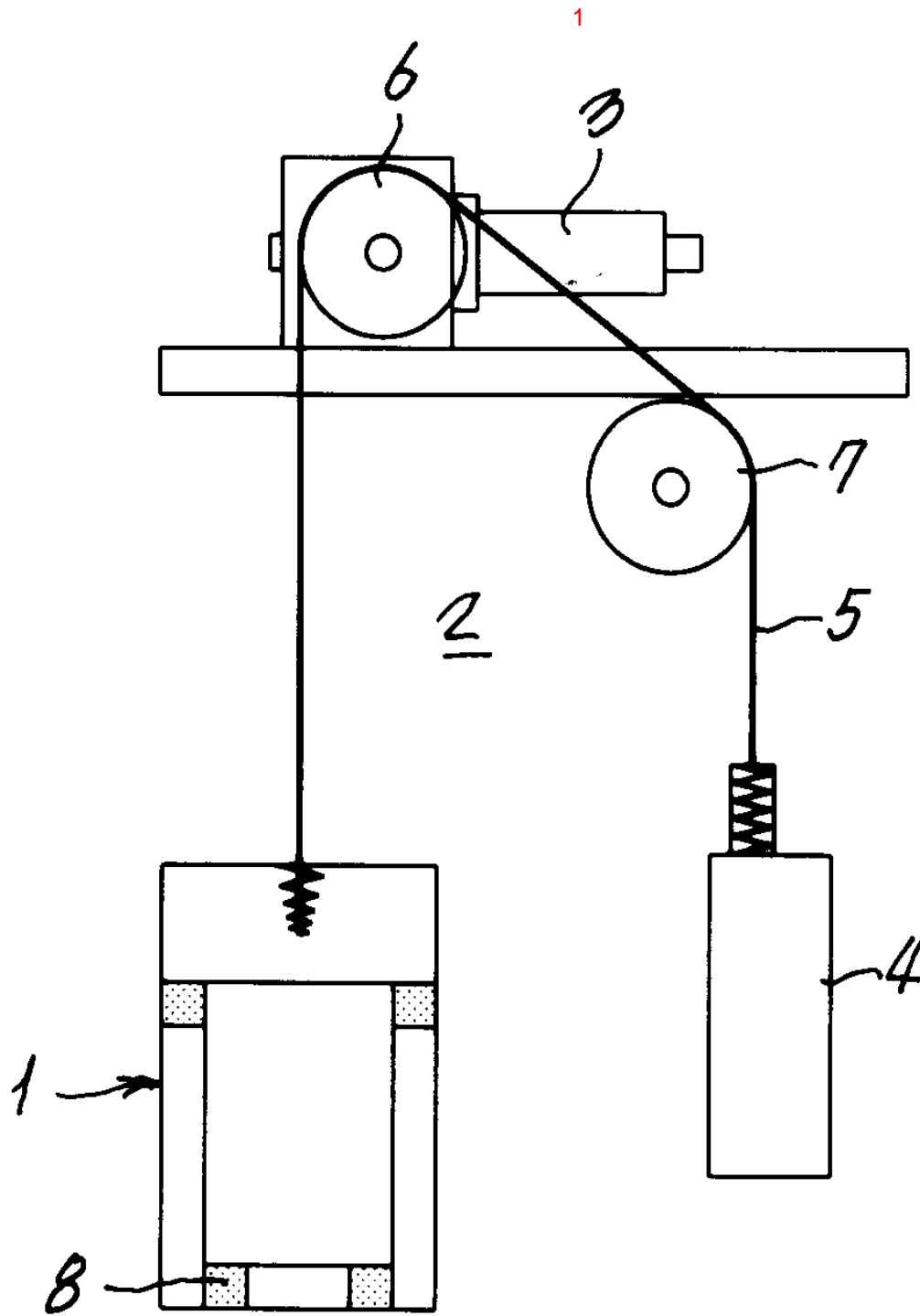

2

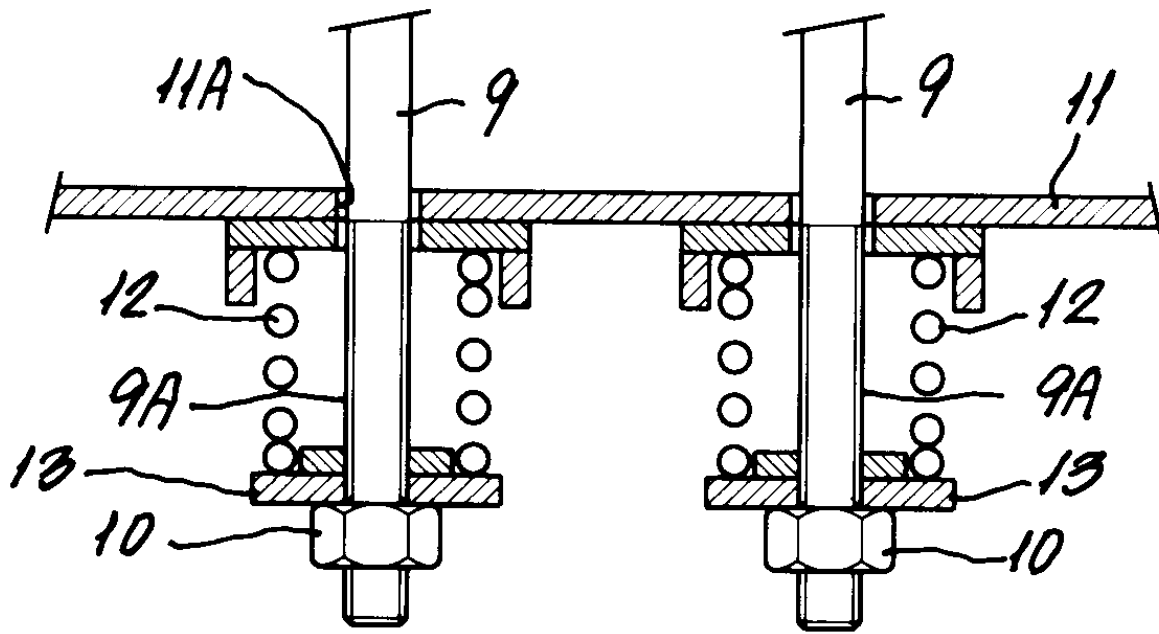

3

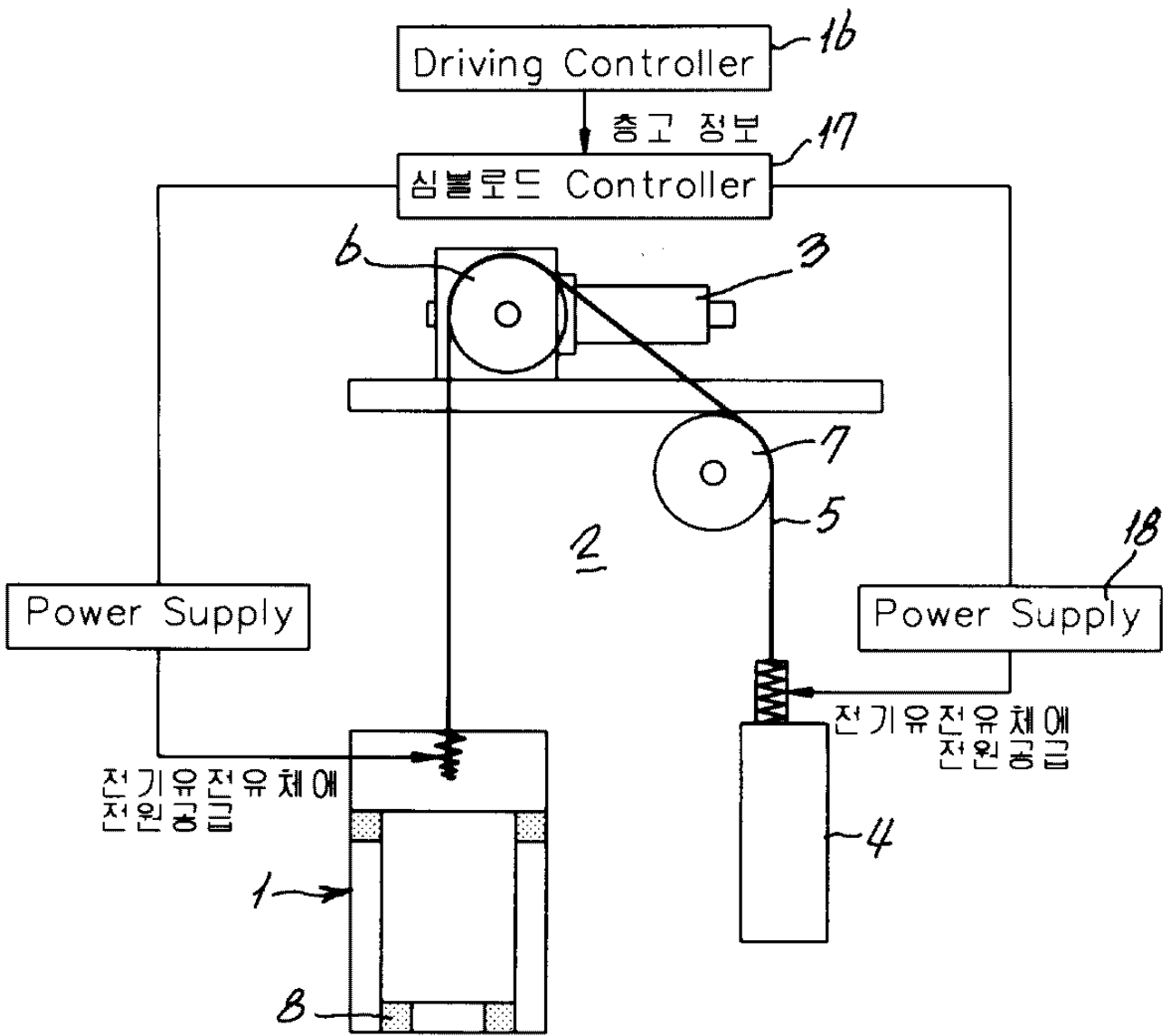

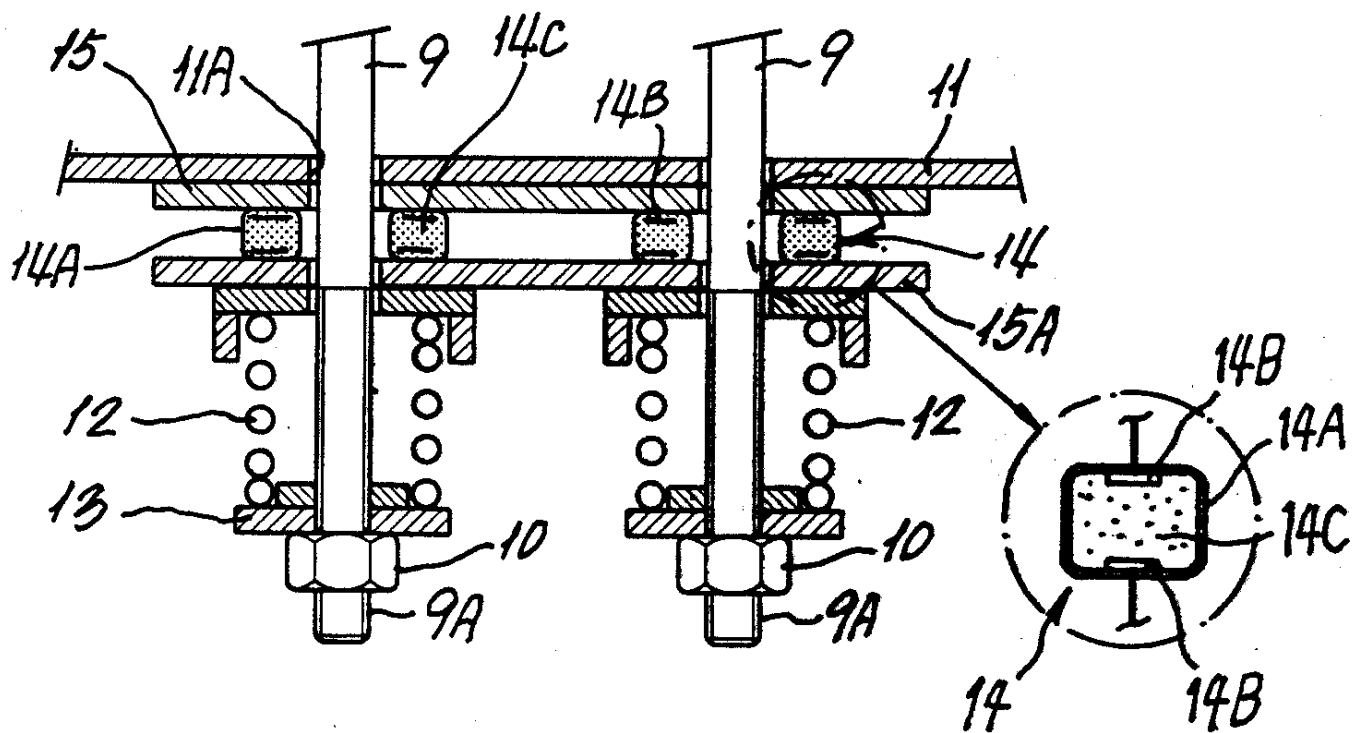



Frequency response function

