



(19) **United States**

(12) **Patent Application Publication**  
**Wang et al.**

(10) **Pub. No.: US 2015/0327221 A1**

(43) **Pub. Date: Nov. 12, 2015**

(54) **METHOD AND APPARATUS FOR SENDING CONTROL SIGNALING**

(71) Applicant: **Huawei Technologies Co., Ltd.**,  
Shenzhen (CN)

(72) Inventors: **Xianghua Wang**, Shenzhen (CN); **Xuan Feng**, Shenzhen (CN)

(21) Appl. No.: **14/713,808**

(22) Filed: **May 15, 2015**

**Related U.S. Application Data**

(63) Continuation of application No. 13/727,932, filed on Dec. 27, 2012, now Pat. No. 9,036,524, which is a continuation of application No. 13/544,238, filed on Jul. 9, 2012, now Pat. No. 8,369,278, which is a continuation of application No. 12/432,882, filed on Apr. 30, 2009, now Pat. No. 8,265,023, which is a continuation of application No. PCT/CN2008/070822, filed on Apr. 28, 2008.

(30) **Foreign Application Priority Data**

Apr. 27, 2007 (CN) ..... 200710097679.0

**Publication Classification**

(51) **Int. Cl.**  
**H04W 72/04** (2006.01)  
**H04L 1/18** (2006.01)

(52) **U.S. Cl.**  
CPC ..... **H04W 72/042** (2013.01); **H04L 1/1819** (2013.01)

(57) **ABSTRACT**

A method of signaling is disclosed. A terminal receives downlink control signaling from a base station and sends an uplink packet to the base station. The uplink packet is sent according to the received downlink control signaling. The downlink control signaling includes a field that includes N bits. The field itself is dynamically indicative of one of a payload size or a redundancy version such that the field itself is indicative of the payload size if a packet that the terminal will send to a base station is an initial transmission and the field itself is indicative of the redundancy version if the packet that the terminal will send to the base station is a retransmission.

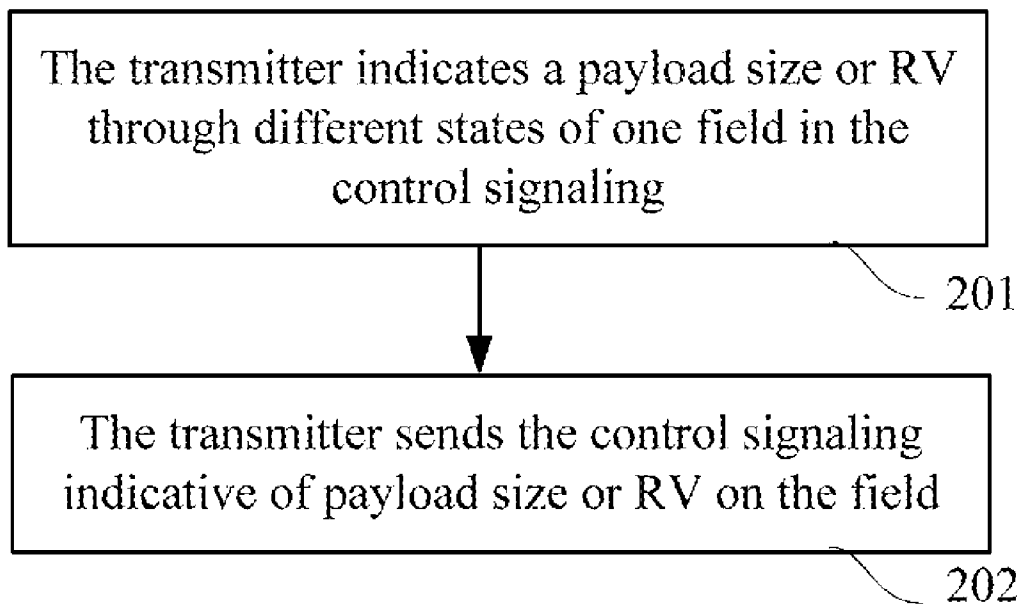

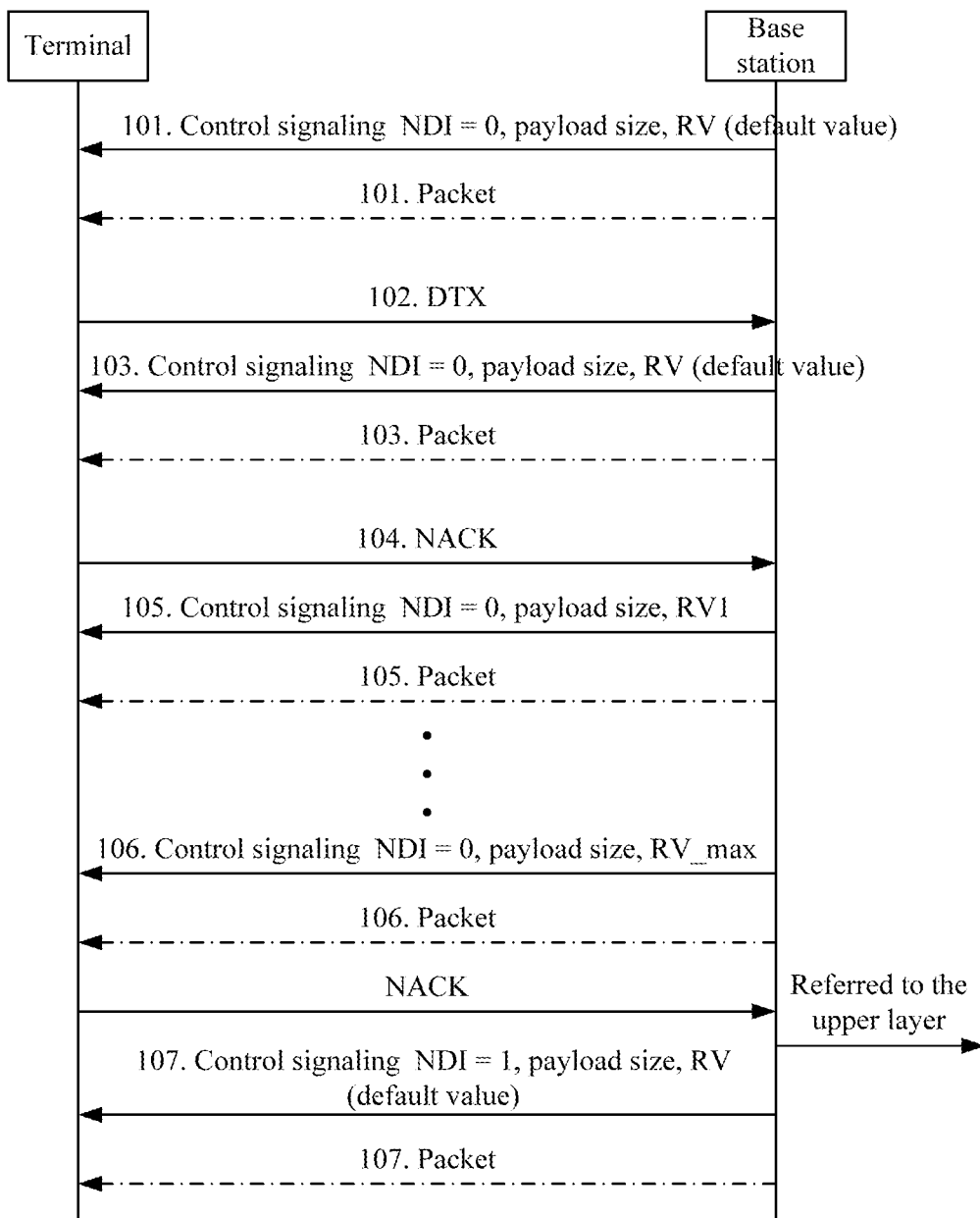

Figure 1 (Prior Art)

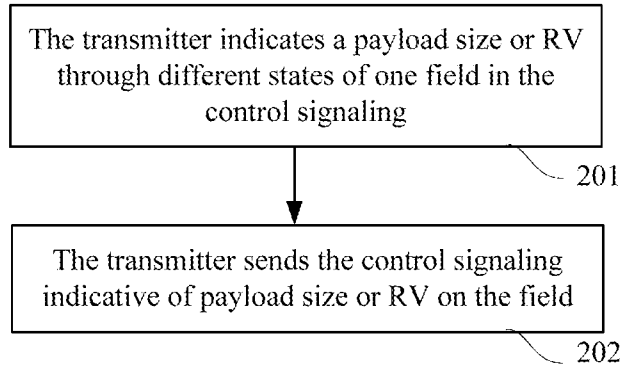

Figure 2

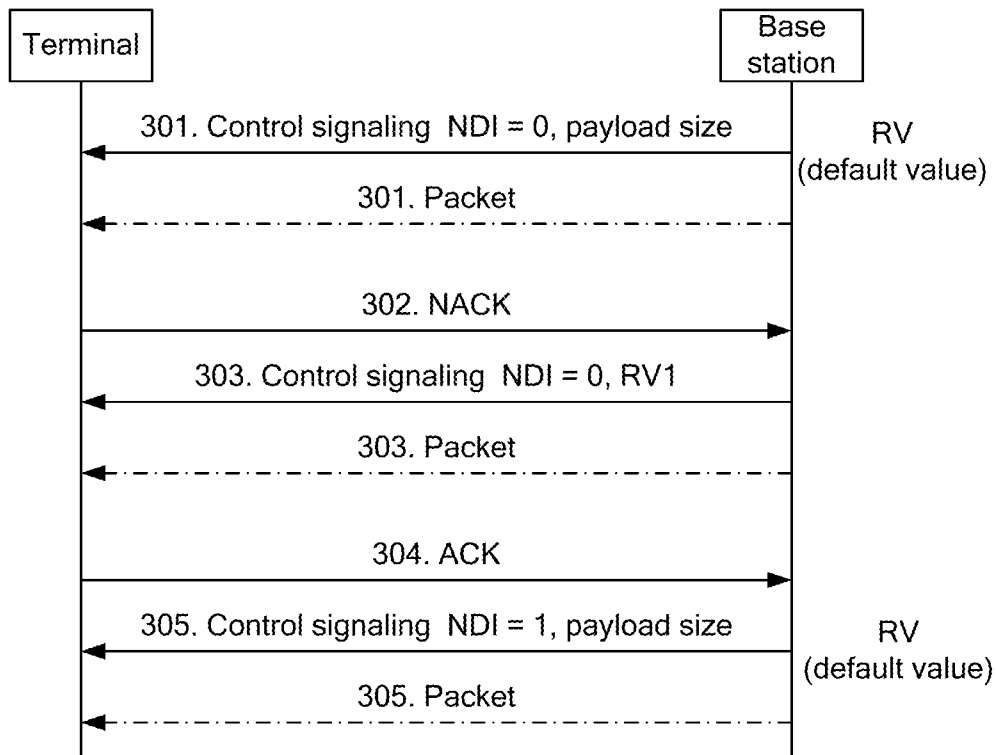

Figure 3

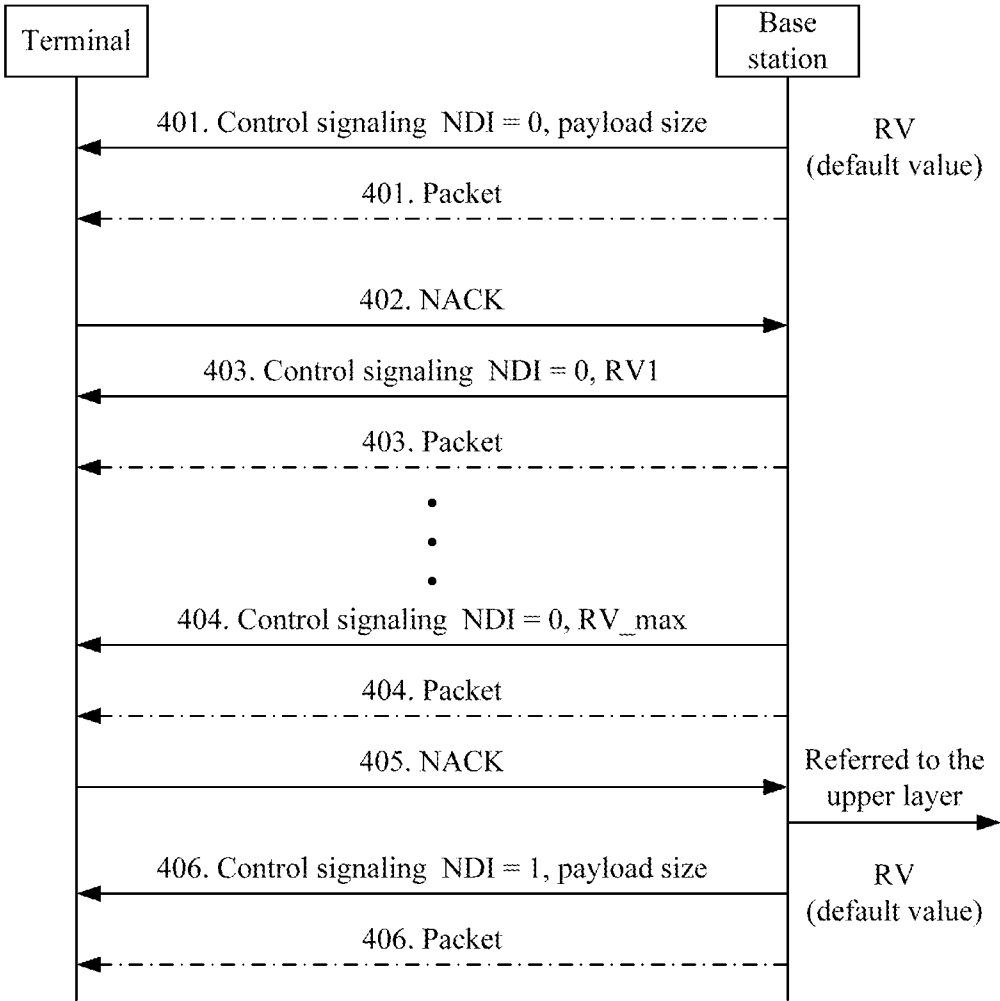

Figure 4

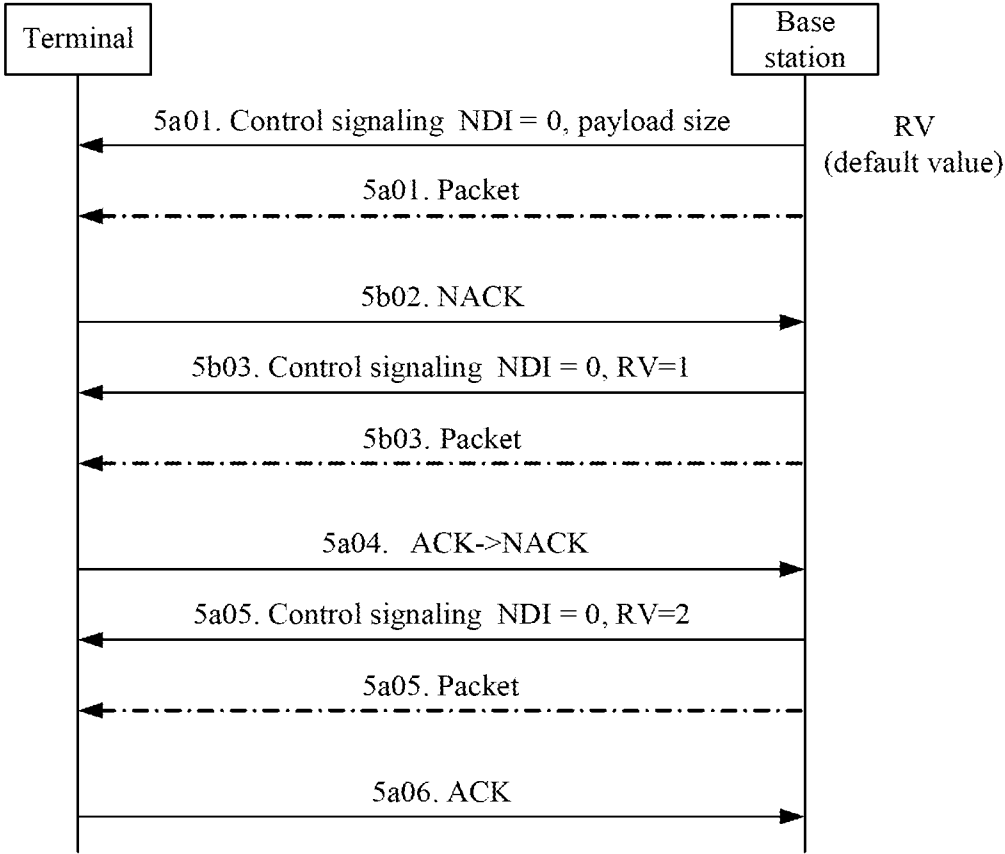

Figure 5a

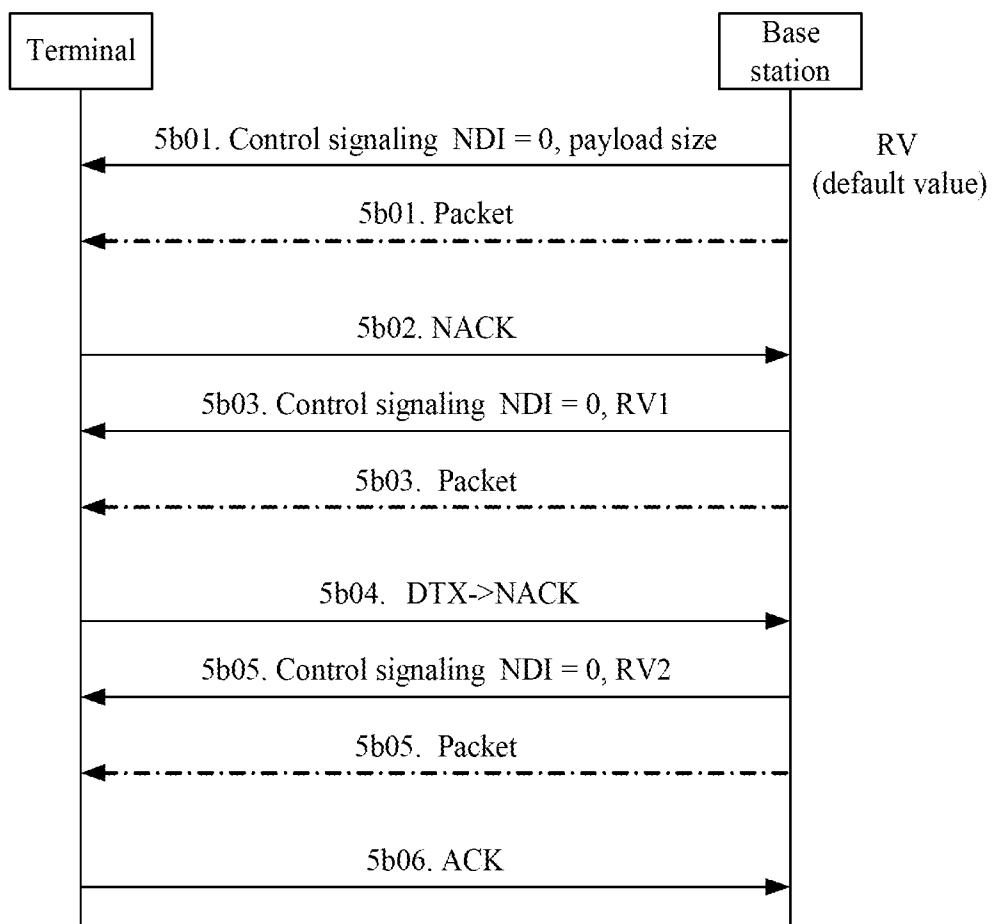

Figure 5b

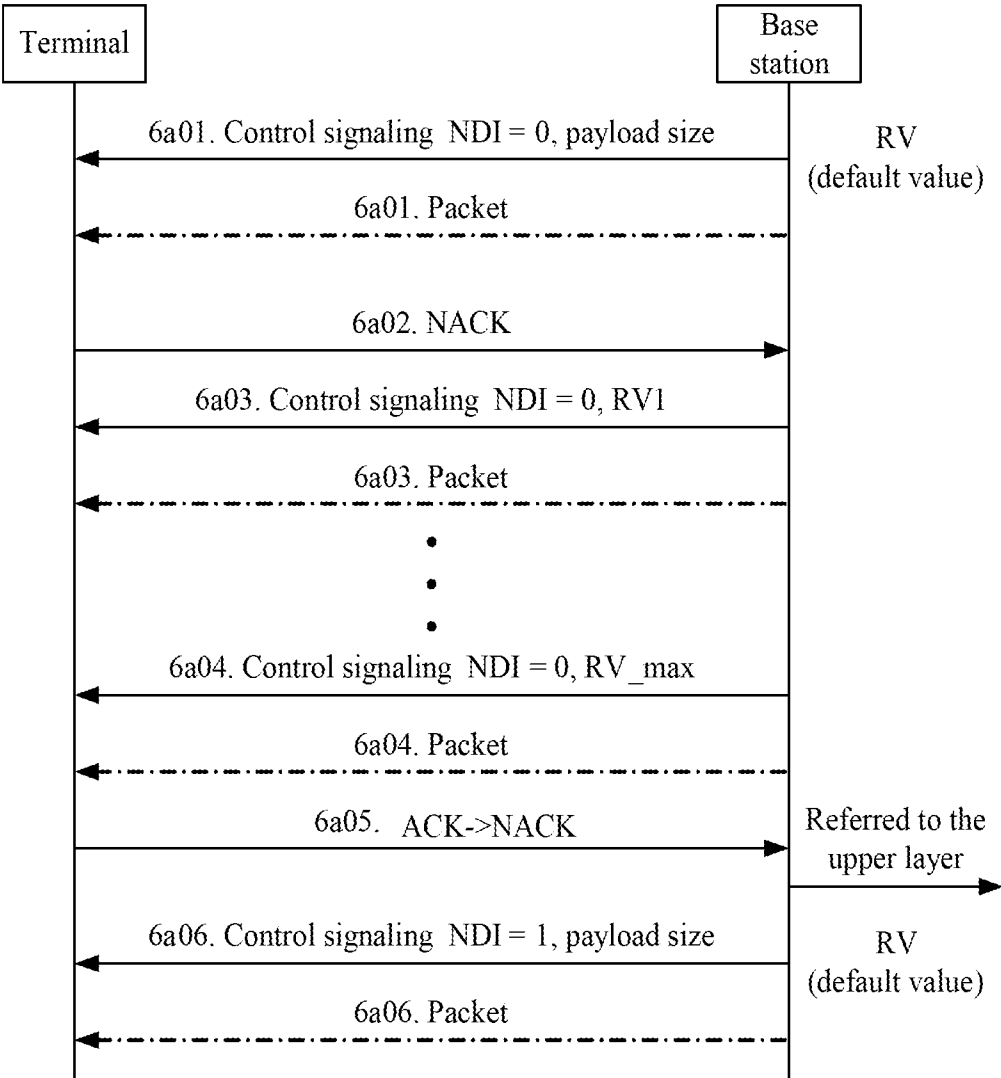

Figure 6a

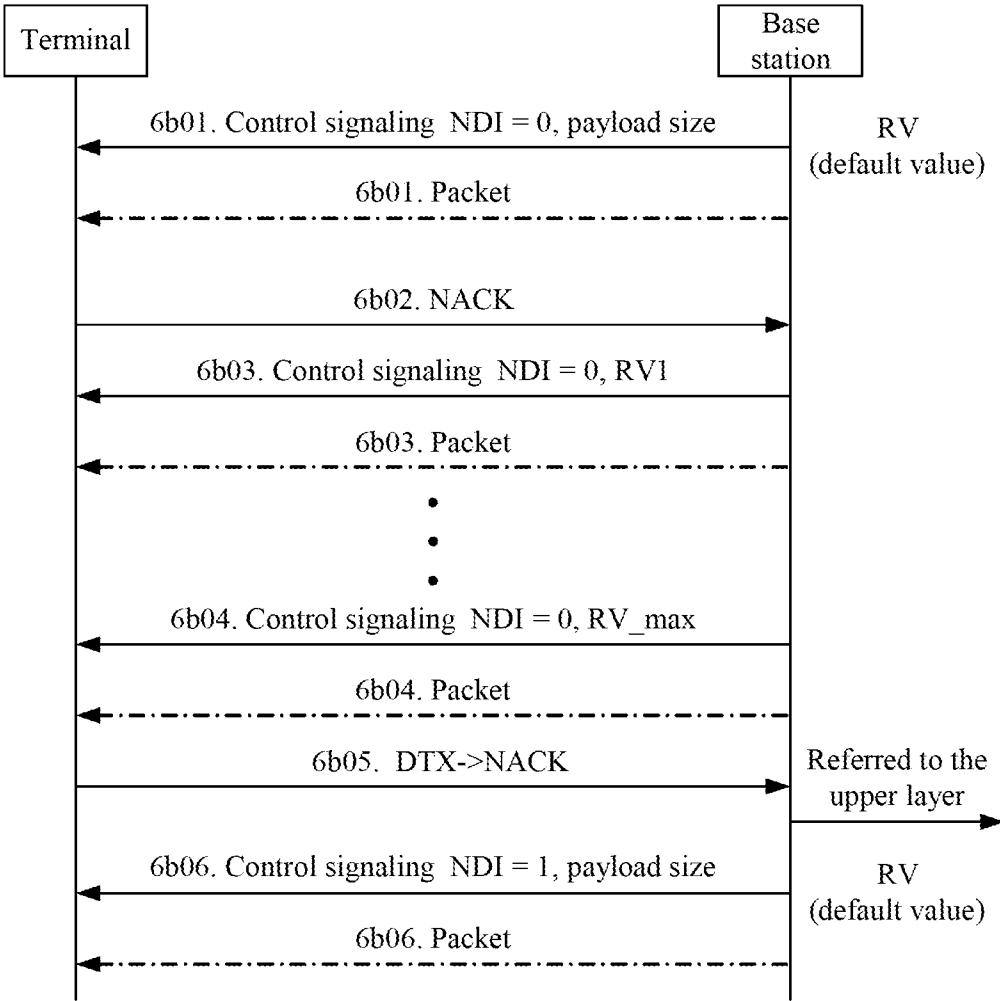

Figure 6b



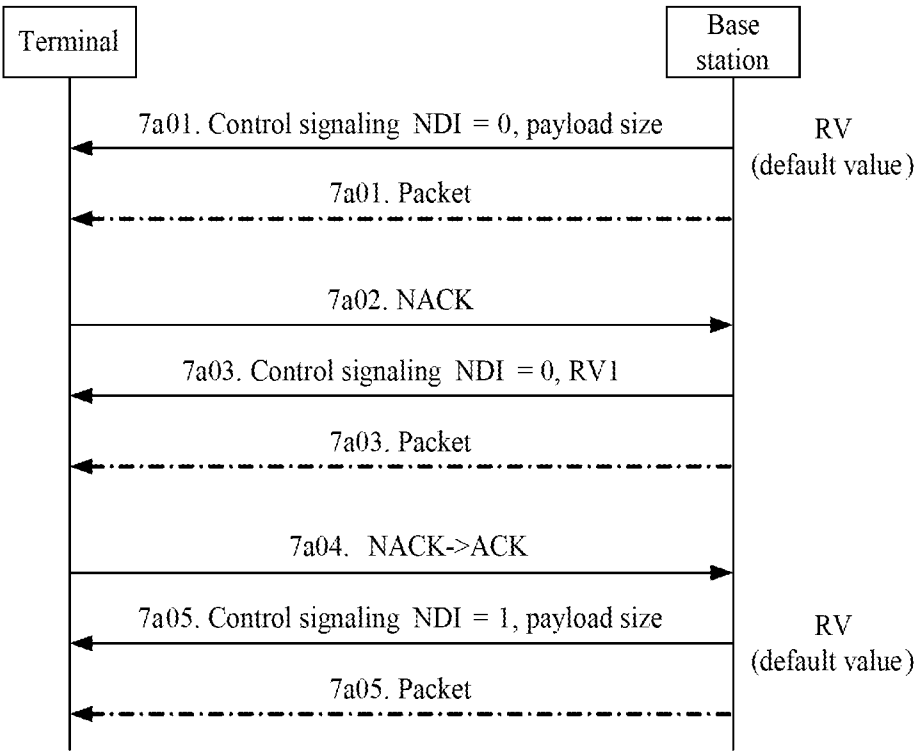

Figure 7a

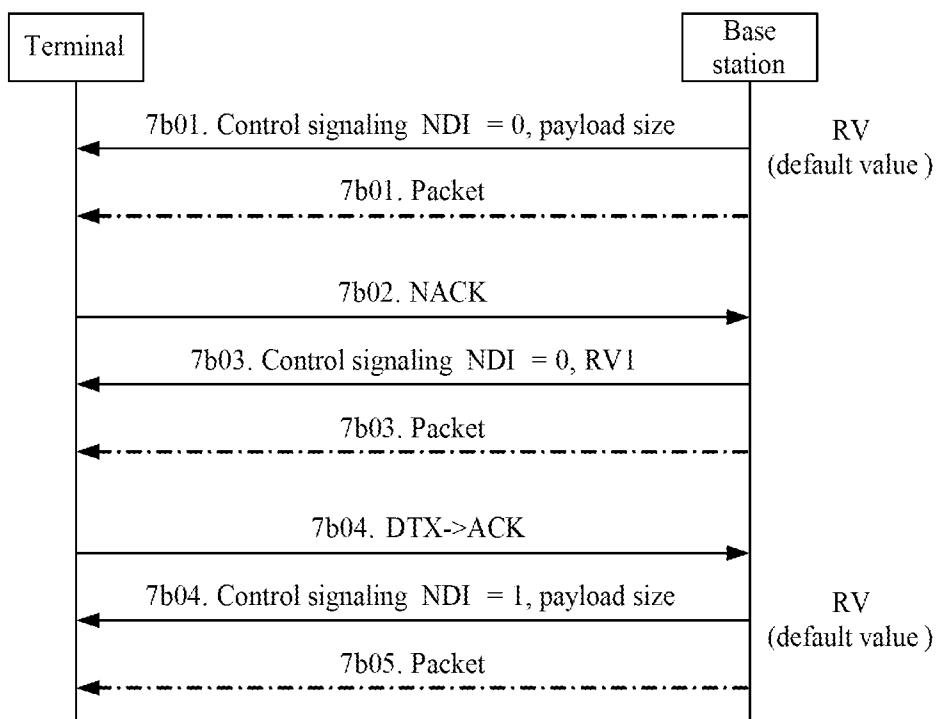

Figure 7b

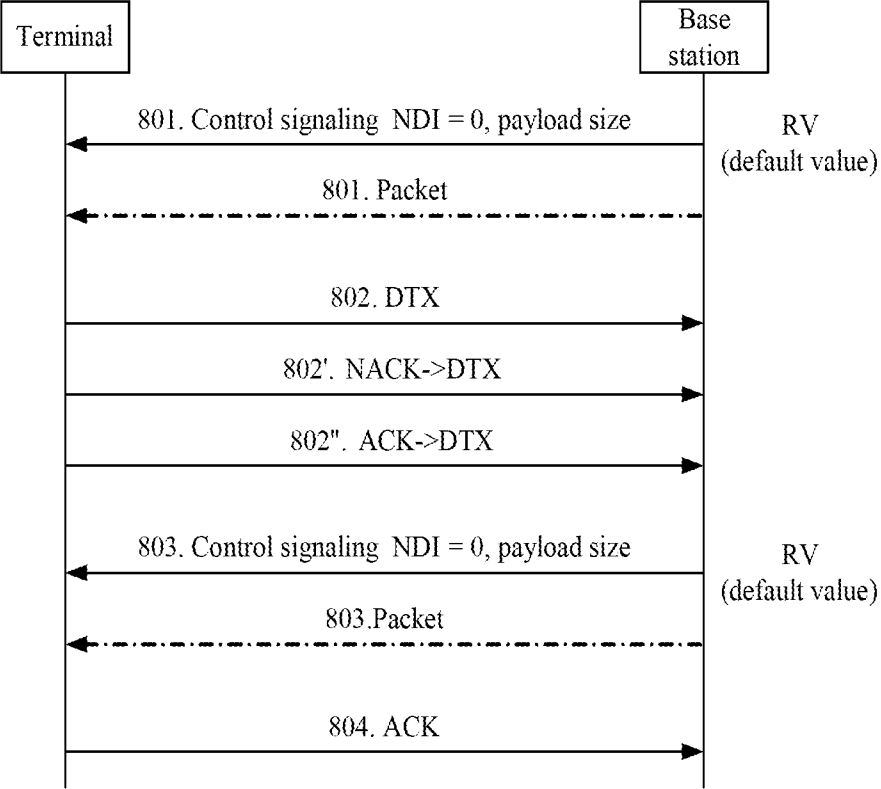

Figure 8

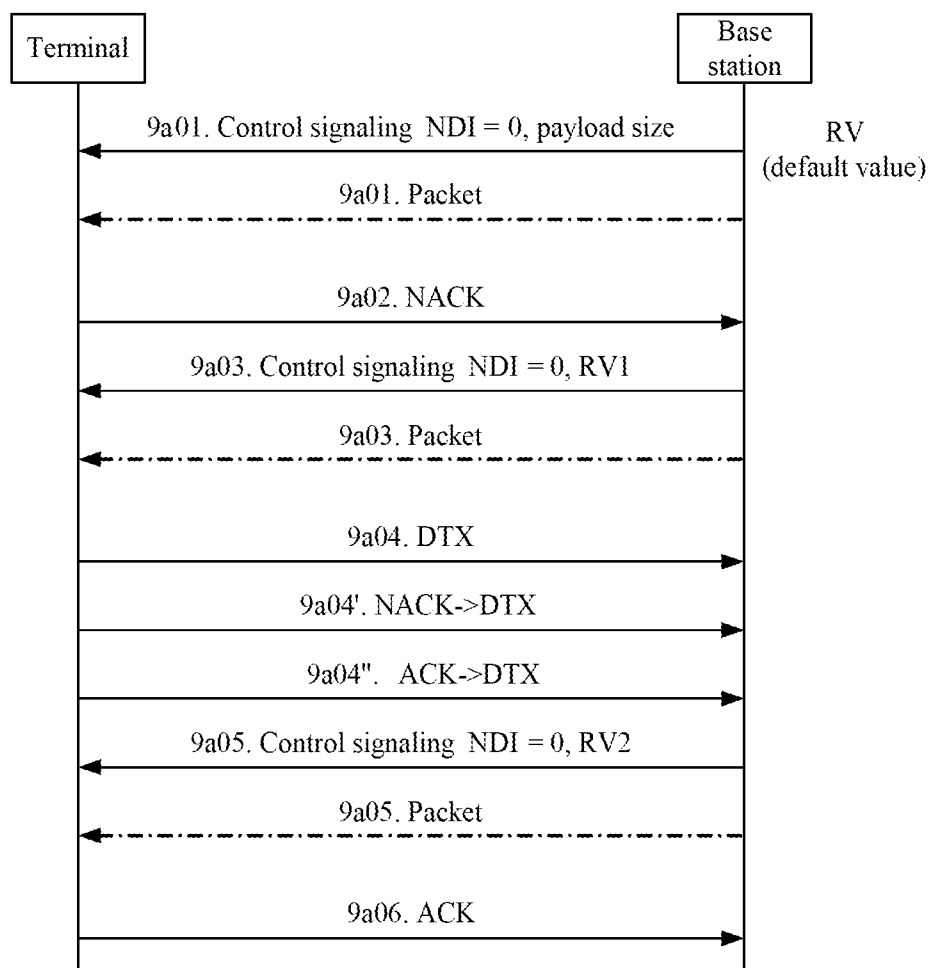

Figure 9a

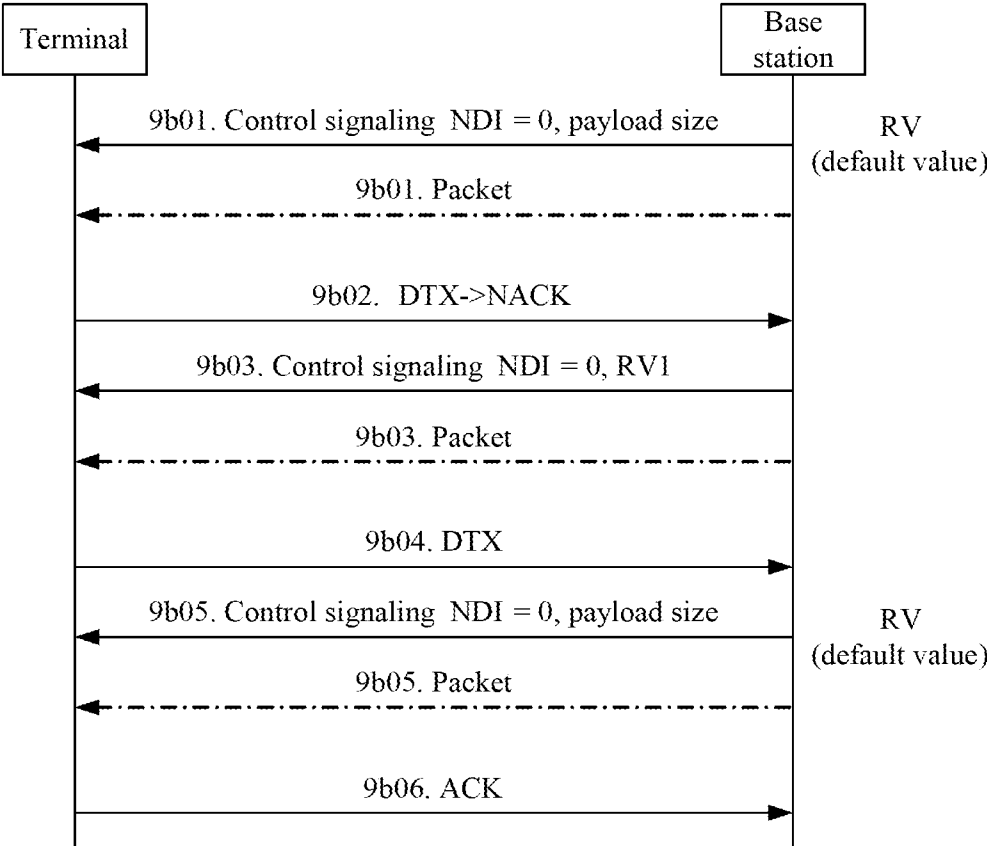

Figure 9b

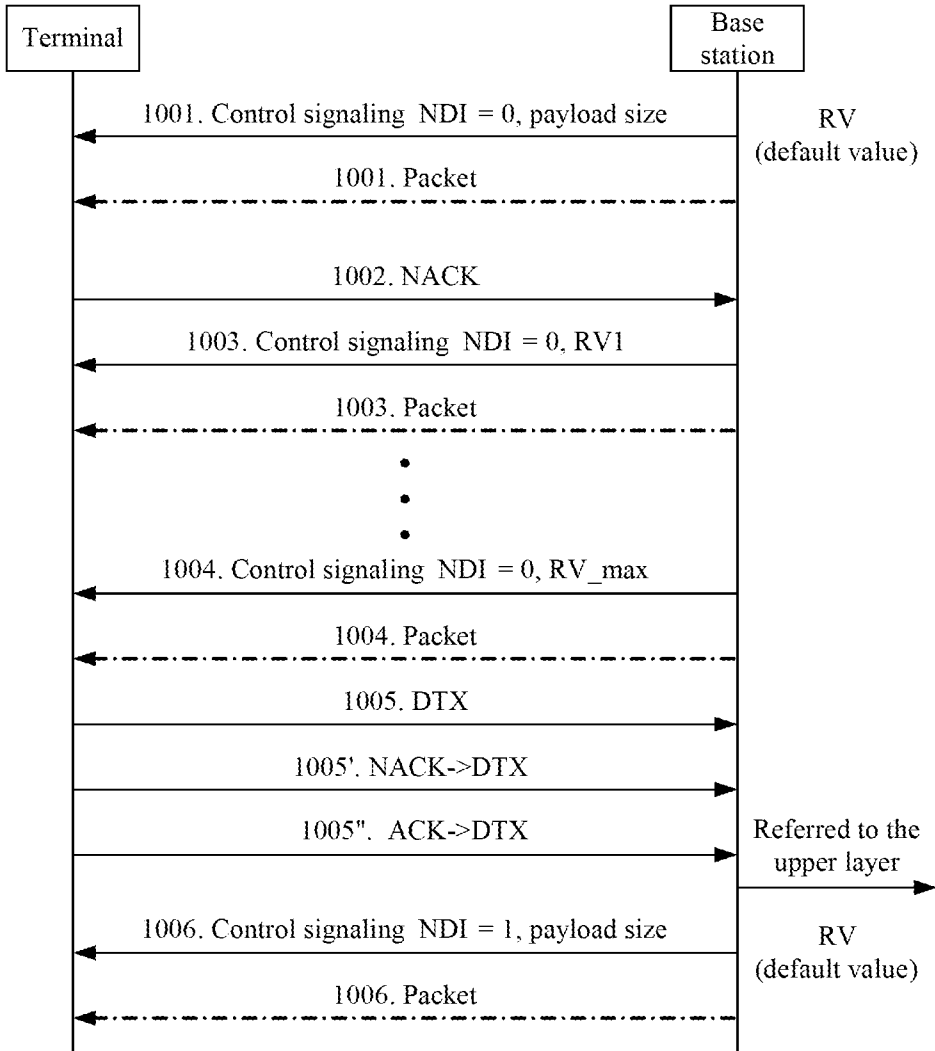

Figure 10

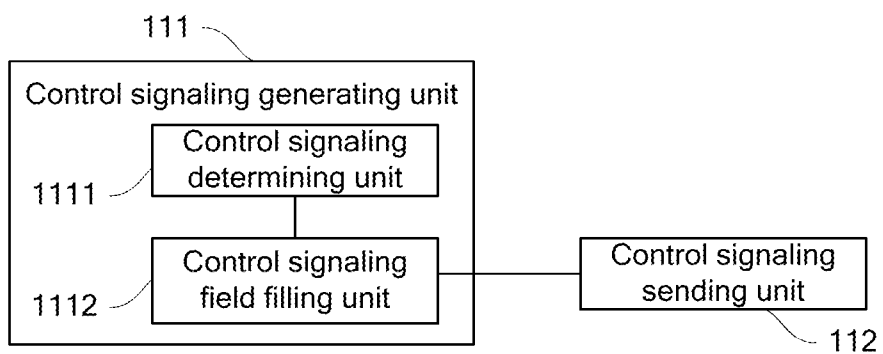

Figure 11

**METHOD AND APPARATUS FOR SENDING CONTROL SIGNALING**

[0001] This application is a continuation of U.S. patent application Ser. No. 13/727,932 filed on Dec. 27, 2012, which is a continuation of U.S. patent application Ser. No. 13/544,238, filed on Jul. 9, 2012 and issued as U.S. Pat. No. 8,369,278 on Feb. 5, 2013, which is a continuation of U.S. patent application Ser. No. 12/432,882, filed on Apr. 30, 2009 and issued as U.S. Pat. No. 8,265,023 on Sep. 11, 2012, which is a continuation of International Application No. PCT/CN2008/070822, filed on Apr. 28, 2008, which claims priority to Chinese Patent Application No. 200710097679.0, filed on Apr. 27, 2007. The afore-mentioned patent applications and patents are hereby incorporated by reference in their entireties.

**TECHNICAL FIELD**

[0002] The present invention relates to radio communication technologies, and in particular, to a method and apparatus for sending control signaling

**BACKGROUND**

[0003] In a radio communication system, by sending control signaling, a control signaling transmitter notifies the control signaling receiver (terminal) of the information on the physical resources and transmission format for transmitting data. The control signaling receiver uses such information to receive downlink transmitted data or send uplink transmitted data. For example, in a Time Division Duplex (TDD) and/or Frequency Division Duplex (FDD) system, the control signaling transmitter needs to notify the timeslot and/or frequency used for transmitting data and other relevant information.

[0004] The transmission of control signaling in a system based on the Hybrid Automatic Repeat reQuest (HARQ) is described below as an example. The HARQ is a mechanism associated with packet retransmission between the data transmitter and the data receiver. If the data transmitter is a base station, the data receiver is a terminal. If the data transmitter is a terminal, the data receiver is a base station. By taking downlink adaptive HARQ as an example, the transmission of control signaling is described below, where the transmitter is a base station and the receiver is a terminal.

[0005] The base station notifies the terminal of allocated physical resources and HARQ-related information through downlink control signaling, and transmits the downlink data to the terminal. The control signaling may include time frequency resource, modulation mode, payload size, HARQ process number, Redundancy Version (RV), and New Data Indicator (NDI).

[0006] If the control signaling received by the terminal is erroneous, Discontinuous Transmission (DTX) is executed, namely, a DTX message is returned to the base station. Upon detecting the DTX fed back by the terminal, the base station sends downlink control signaling again and transmits packets.

[0007] If the control signaling received by the terminal is correct, the terminal receives packets as indicated by the control signaling. After receiving the packets correctly, the terminal returns a success acknowledgement (ACK) message to the base station, indicating that the current packet is received correctly. Subsequently, the base station sends the control signaling corresponding to the next packet, and sends

the next packet. If the terminal fails to receive the packet correctly, the terminal returns a packet transmission failure acknowledgement, namely, Negative ACKnowledgement (NACK) message, to the base station, and the base station retransmits the control signaling and the packet which is not received by the terminal correctly.

[0008] The data transmitter can retransmit the packet for a limited number of times. If a packet is retransmitted for a threshold number of times but is still not received by the receiver successfully, the packet is referred to the upper layer.

[0009] In the foregoing process, for every attempt of transmitting the packet from the base station, no matter whether it is initial transmission or retransmission, the base station notifies the terminal through downlink control signaling.

[0010] The sent control signaling includes the fields such as physical resource indication, NDI, payload size, and RV. When a new packet is transmitted initially, the NDI value is different from that on the previous occasion. Specifically, if the value range of the NDI is 0 or 1, the NDI changes from 0 to 1, or from 1 to 0, when a new packet is transmitted initially. The value of RV is generally the default value in the initial transmission. If the packet is retransmitted, the NDI value is the same as that in the previous transmission, and the RV value changes. In this example, the RV is marked RV1 when the packet is retransmitted for the first time, marked RV2 when the packet is retransmitted for the second time, marked RV3 when the packet is retransmitted for the third time, marked RV4 when the packet is retransmitted for the fourth time, and so on. In the initial transmission and retransmission of the same packet, the payload size is the same. That is, the payload size needs to be indicated only in the initial transmission.

[0011] FIG. 1 is an exemplary signaling flow in a downlink adaptive HARQ process. As shown in FIG. 1, the process is as follows:

[0012] Step 101: The base station sends control signaling corresponding to the packet, and sends the packet initially (illustrated by dotted line 101 in FIG. 1), supposing that the control signaling indication NDI=0. The value of the payload size and the value of RV are indicated, and RV may adopt the default value.

[0013] Step 102: The terminal returns DTX. In this step, the terminal fails to receive the control signaling, and therefore, returns a DTX.

[0014] Step 103: The base station sends the control signaling again, and sends the packet initially (as illustrated by dotted line 103 in FIG. 1), where the value of NDI, the value of payload size, and the value of RV are the same as on the previous occasion, and the value of RV is the default value.

[0015] Step 104: The terminal returns a NACK message to the base station. In this step, the terminal receives the control signaling successfully, and therefore, the terminal receives the packet as indicated by the control signaling. If the terminal fails to receive the initially transmitted packet, the terminal returns a NACK to the base station.

[0016] Step 105: The base station sends control signaling corresponding to the retransmitted packet, and retransmits the packet (illustrated by dotted line 105 in FIG. 1). In this step, the packet is retransmitted for the first time. Therefore, in the control signaling, NDI=0, the value of the payload size is the same as that in the initial transmission, and the RV value is RV1 which is different from that on the previous occasion.

[0017] Afterwards, if the terminal still fails to receive the packet correctly, the base station keeps retransmitting the



control signaling and the corresponding packet (as illustrated by step 106 and dotted line 106 in FIG. 1) until the threshold count of retransmission is reached. In the control signaling of retransmission, value of payload size is the same, and the RV changes. If the terminal still fails to receive the packet when the threshold count of retransmission is reached, the packet is referred to the upper layer.

[0018] Further, the base station sends control signaling of the new packet, and transmits the new packet. As shown in step 107 and dotted line 107, where the NDI in the control signaling is NDI=1 which is different from the NDI of the previous packet, the control signaling indicates the value of the payload size and the value of RV, and the value of the RV is the default value.

[0019] It is necessary to point out that the foregoing base station is a transmitter of the packet, and the terminal is a receiver of the packet. However, in the case of uplink data transmission, the data transmitter is a terminal, and the data receiver is a base station.

[0020] In the foregoing process, in the initial transmission of the packet, the RV in the corresponding control signaling may be a default value. The default value may not be indicated in the control signaling. Moreover, if the control signaling transmitted initially is received by the receiver successfully, namely, the receiver obtains the payload size successfully, the corresponding control signaling does not need to indicate the payload size again in the packet retransmission. That is, in the prior art, when the packet is transmitted initially and retransmitted, the control signaling needs to indicate both the RV and the payload size, and the RV indicated by the control signaling in the case of initially transmitting the packet and the payload size indicated by the control signaling in the case of retransmitting the packet are information not required to be indicated, which leads to waste of physical resources.

#### SUMMARY OF THE INVENTION

[0021] A method and apparatus for sending control signaling are provided consistent with the embodiments disclosed herein to reduce waste of physical resources at the time of sending control signaling.

[0022] A method for sending control signaling in some embodiments may include: indicating, by the transmitter, a payload size or Redundancy Version (RV) through different states of one field in the control signaling; and sending the control signaling indicative of the payload size or RV on the field.

[0023] Accordingly, an apparatus for sending control signaling consistent with some embodiments may include multiple units, including, for example: a control signaling generating unit 111, adapted to generate control signaling, where different states of one field in the control signaling indicate a payload size or RV; and a control signaling sending unit 112, adapted to send the control signaling indicative of the payload size or RV on the field.

[0024] The technical solution consistent with some embodiments may provide different states of one field in the control signaling indicate the payload size or RV. At the time of sending the control signaling, the payload size or RV sent, may be indicated in the field, thus vacating the field occupied by the information not required to be indicated, and saving physical resources.

#### BRIEF DESCRIPTION OF THE DRAWINGS

[0025] For a more complete understanding of the present invention, and the advantages thereof, reference is now made to the following descriptions taken in conjunction with the accompanying drawing, in which:

[0026] FIG. 1 is an exemplary signaling flowchart of HARQ in the prior art;

[0027] FIG. 2 is an exemplary flowchart consistent with some embodiments of the present disclosure;

[0028] FIG. 3 is an exemplary signaling flowchart in scenario 1 consistent with some embodiments of the present disclosure;

[0029] FIG. 4 is an exemplary signaling flowchart in scenario 2 consistent with some embodiments of the present disclosure;

[0030] FIG. 5a and FIG. 5b are exemplary signaling flowcharts in scenario 3 consistent with some embodiments of the present disclosure;

[0031] FIG. 6a and FIG. 6b are exemplary signaling flowcharts in scenario 4 consistent with some embodiments of the present disclosure;

[0032] FIG. 7a and FIG. 7b are exemplary signaling flowcharts in scenario 5 consistent with some embodiments of the present disclosure;

[0033] FIG. 8 is an exemplary signaling flowchart in scenario 6 consistent with some embodiments of the present disclosure;

[0034] FIG. 9a and FIG. 9b are exemplary signaling flowcharts in scenario 7 consistent with some embodiments of the present disclosure;

[0035] FIG. 10 is an exemplary signaling flowchart in scenario 8 consistent with some embodiments of the present disclosure; and

[0036] FIG. 11 is an exemplary block diagram of an apparatus consistent with some embodiments of the present disclosure.

#### DETAILED DESCRIPTION OF ILLUSTRATIVE EMBODIMENTS

[0037] A method for sending control signaling is provided in embodiments disclosed herein, including: indicating payload size or RV based on different states of one field in the control signaling; and sending, in response to the indication, the control signaling indicative of the payload size or RV in the field, thus vacating the field occupied by the information not required to be indicated, and saving physical resources.

[0038] In the initial transmission of the packet, the RV in the corresponding control signaling may be a default value. The default value may not be indicated in the control signaling. Moreover, if the control signaling transmitted initially is received by the receiver successfully, namely, the receiver obtains the payload size successfully, the corresponding control signaling does not need to indicate the payload size again in the packet retransmission. In fact, every transmission of a packet may be either an initial transmission or a retransmission. Therefore, the control signaling in every transmission may indicate either payload size or RV.

[0039] Accordingly, the embodiments disclosed herein are described below. In order to make the technical solution clearer to those skilled in the art, the technical solution is hereinafter described in detail by reference to embodiments and accompanying drawings.

**[0040]** FIG. 2 is an exemplary flowchart consistent with some embodiments. As shown in FIG. 2, the process may include the following steps.

**[0041]** Step 201: Different states of one field in the control signaling may indicate a payload size or RV.

**[0042]** Specifically, this step is to specify which states of the field indicate the payload size, and which states indicate the RV. It is appropriate that some states of the field indicate the payload size, and the remaining states indicate the RV. A corresponding relation exists between the physical resource, transmission format (Modulation Code Style (MCS)), and payload size. Therefore, the corresponding payload size may be determined based on the allocated physical resources and transmission format (MCS). If physical resources are indicated, the payload size may be indicated implicitly by indicating the transmission format (MCS).

**[0043]** Detailed description is given below, based on an example where the field indicative of the payload size occupies 6 bits and the field indicative of the RV occupies 2 bits. In this embodiment, the RV exists in a total of 4 states ( $2^2=4$ ). Therefore, the field indicative of the RV occupies 2 bits. The payload size exists in a total of 60 states, but  $2^5=32$  which is not enough for indicating 60 states. Considering  $2^6=64$ , the field for indicating the payload size needs to occupy 6 bits. Therefore, a 6-bit field is capable of indicating 64 states in total, 4 of the 64 states indicate the RV, and the remaining 60 states indicate the payload size. In this way, a 6-bit field is enough for indicating both the payload size and the RV. The 2 bits occupied by the RV in the prior art are saved in the present embodiments.

**[0044]** For ease of identification, in a 6-bit field, 4 states whose foremost upper bits are all 0s can indicate 4 different RVs. That is, the 4 states 000000, 000001, 000010 and 000011 indicate RV1-RV4. Accordingly, the remaining 60 states (any bit in the 4 foremost upper bits of the remaining 60 states is non-zero) indicate 60 different payload sizes. Therefore, when the control signaling is received, it is practicable to judge whether the field in the control signaling indicates the payload size or the RV by only detecting the state code.

**[0045]** The foregoing example shows that different states of one field in the control signaling are enough for indicating all values of the payload size and RV.

**[0046]** Step 202: The transmitter sends the control signaling indicative of the payload size or RV in the field. That is, the control signaling indicative of the payload size or RV in the field is sent to the receiver.

**[0047]** Specifically, this step may help determine whether the field of the control signaling to be sent indicates the payload size or RV, fill the field of the control signaling according to the specific payload size or RV, and send the control signaling. For example, in the initial transmission of the packet, the transmitter sends the control signaling indicative of the payload size on the same field to the receiver. Upon detecting a DTX, the transmitter sends the control signaling indicative of the payload size or RV on the same field. Upon detecting a NACK, the transmitter sends the control signaling indicative of the RV on the same field.

**[0048]** Upon detecting an ACK, the transmitter transmits a new packet initially, the field in the corresponding control signaling bears the payload size, and the default value of the RV applies.

**[0049]** When the control signaling received by the receiver is erroneous, a DTX message is returned. Accordingly, after receiving the DTX message, the transmitter sends the control

signaling again to start retransmission of the packet. Generally, it is practicable to determine whether the field in the control signaling indicates the payload size or RV according to whether the count of transmission of the packet reaches a pre-defined value. If the count of transmission of the packet reaches or exceeds the pre-defined value, it is determined that the terminal obtains the payload size successfully in the previous transmission process. Therefore, the transmitter may indicate the RV on the foregoing field in the next signaling transmission. If the count of transmission of the packet does not reach the pre-defined value, the control signaling transmitter indicates the payload size on the field in the next signaling transmission.

**[0050]** If the receiver receives the control signaling correctly without receiving the corresponding packet correctly, the receiver returns a NACK message. Upon detecting the NACK message, the transmitter sends the control signaling to the receiver again. The field in the control signaling indicates the RV. Accordingly, the transmitter retransmits the packet after sending the control signaling.

**[0051]** Described above is a process in which the transmitter sends control signaling to the receiver and sends a packet to the receiver, and the receiver receives the packet according to the control signaling. After the transmitter sends the control signaling to the receiver, the receiver may also send data to the transmitter according to the control signaling. It is worthy of attention that the foregoing transmitter may be a base station, and the receiver may be a terminal. That is, in the downlink transmission, the base station sends downlink control signaling and a packet to the terminal and the terminal receives the packet from the base station according to the downlink control signaling. Likewise, in the uplink transmission, the terminal can send a packet to the base station to perform uplink data transmission according to the downlink control signaling sent by the base station.

**[0052]** Taking downlink data transmission as an example, the foregoing embodiment applied in different scenarios is described below.

**[0053]** Scenario 1: FIG. 3 is an exemplary signaling flowchart in scenario 1 consistent with some embodiments.

**[0054]** Step 301: The base station sends the control signaling corresponding to the packet initially and sends the packet (as illustrated by dotted line 301 in FIG. 3), where the NDI=0 in the control signaling. The state on a specific field in the control signaling is used to indicate the payload size, and the default value of the RV applies. The specific field may be any field applicable for indicating the payload size or RV in the control signaling. In the following scenarios, the specific field may be obtained in the same way as in this scenario.

**[0055]** Step 302: The terminal fails to receive the packet, and returns a NACK.

**[0056]** Step 303: The base station sends the control signaling again, and retransmits the packet (as illustrated by dotted line 303 in FIG. 3), where NDI=0 in the control signaling. A state on the specific field indicates the RV1.

**[0057]** Step 304: The terminal receives the packet successfully, and returns an ACK.

**[0058]** Step 305: The base station sends the control signaling of a new packet (namely, the next packet) and the new packet initially, where the NDI=1 in the control signaling. A state on the specific field indicates the payload size, and the default value of the RV applies.

[0059] Scenario 2: FIG. 4 is an exemplary signaling flow-chart in scenario 2 consistent with some embodiments of the present invention.

[0060] Step 401: The base station sends the control signaling corresponding to the packet initially and sends the packet (as illustrated by dotted line 401 in FIG. 4), where the NDI=0 in the control signaling. A state on the specific field in the control signaling indicates the payload size, and the default value of the RV applies.

[0061] Step 402: The terminal fails to receive the packet, and returns a NACK.

[0062] Step 403: The base station sends the control signaling again, and retransmits the packet (as illustrated by dotted line 403 in FIG. 3), where NDI=0 in the control signaling. A state on the specific field indicates the RV1. In the subsequent retransmission process, the terminal fails to receive the packet.

[0063] Step 404: The base station sends the control signaling corresponding to the packet in a last attempt, and retransmits the packet (as illustrated by dotted line 404 in FIG. 3), where NDI=0 in the control signaling. A state on the specific field indicates the RV\_max, where RV\_max indicates the RV at the maximum retransmission count.

[0064] Step 405: The terminal fails to receive the packet, and returns a NACK.

[0065] Because the maximum retransmission count is reached, the packet is referred to the upper layer.

[0066] Step 406: The base station sends the control signaling corresponding to a new packet (namely, the next packet) initially and sends the new packet, where the NDI=1 in the control signaling. A state on the specific field indicates the payload size, and the default value of the RV applies.

[0067] Scenario 3: In this scenario, the information returned by the terminal is mistaken as a NACK by the base station, and the retransmission count does not reach the maximum retransmission count. As shown in FIG. 5a, the ACK is mistaken as NACK. As shown in FIG. 5b, the DTX is mistaken as NACK in the retransmission process.

[0068] FIG. 5a illustrates the following steps.

[0069] Step 5a01: The base station sends the control signaling corresponding to the packet initially and sends the packet (as illustrated by dotted line 5a01), where the NDI=0 in the control signaling. A state on the specific field in the control signaling indicates the payload size, and the default value of the RV applies.

[0070] Step 5a02: The terminal fails to receive the packet, and returns a NACK.

[0071] Step 5a03: The base station sends the control signaling again, and retransmits the packet (as illustrated by dotted line 5a03), where NDI=0 in the control signaling. A state on the specific field indicates the RV1.

[0072] Step 5a04: The terminal receives the packet successfully, and therefore, returns an ACK, which is mistaken as NACK by the base station.

[0073] Step 5a05: The base station sends the control signaling again, and retransmits the packet (as illustrated by dotted line 5a05), where NDI=0 in the control signaling. A state on the specific field indicates the RV2.

[0074] Step 5a06: The terminal receives the packet successfully, and therefore, returns an ACK.

[0075] As regards the scenario shown in FIG. 5b, in step 5b04, the terminal fails to receive the control signaling and returns a DTX, which is mistaken as NACK by the base

station. The remaining steps are the same as the counterpart in FIG. 5a, and are not repeated here any further.

[0076] Scenario 4: In this scenario, the information returned by the terminal is mistaken as a NACK by the base station when the retransmission count reaches the maximum retransmission count. As shown in FIG. 6a the ACK is mistaken as NACK. As shown in FIG. 6b, the DTX is mistaken as NACK.

[0077] FIG. 6a illustrates the following steps.

[0078] Step 6a01: The base station sends the control signaling corresponding to the packet initially and sends the packet (as illustrated by dotted line 6a01), where the NDI=0 in the control signaling. A state on the specific field in the control signaling indicates the payload size. The default value of the RV applies.

[0079] Step 6a02: The terminal fails to receive the packet, and therefore, returns a NACK.

[0080] Step 6a03: The base station sends the control signaling again, and retransmits the packet (as illustrated by dotted line 6a03), where NDI=0 in the control signaling. A state on the specific field indicates the RV1.

[0081] In the subsequent retransmission process, the terminal fails to receive the packet.

[0082] Step 6a04: The base station sends the control signaling corresponding to the packet at the last attempt, and retransmits the packet (as illustrated by dotted line 6a04), where NDI=0 in the control signaling. A state on the specific field indicates the RV\_max.

[0083] Step 6a05: The terminal receives the packet successfully, and therefore, returns an ACK, which is mistaken as NACK by the base station.

[0084] Because the maximum retransmission count is reached, the packet is referred to the upper layer.

[0085] Step 6a06: The base station sends the control signaling corresponding to a new packet (namely, the next packet) initially and sends the new packet (illustrated by dotted line 6a06), where the NDI=1 in the control signaling. A state on the specific field indicates the payload size. The default value of the RV applies.

[0086] Based on the scenario shown in FIG. 6b, in step 6b05, the terminal fails to receive the control signaling and returns a DTX, which is mistaken as NACK by the base station. The remaining steps may be similar to the counterpart in FIG. 6a, and are not repeated here any further.

[0087] Scenario 5: In this scenario, the information returned by the terminal is mistaken as an ACK by the base station, and in response, the base station transmits a new packet. As shown in FIG. 7a, the NACK is mistaken as ACK. As shown in FIG. 7b, the DTX is mistaken as ACK.

[0088] FIG. 7a illustrates the following steps.

[0089] Step 7a01: The base station sends the control signaling corresponding to the packet initially and sends the packet (as illustrated by dotted line 7a01), where the NDI=0 in the control signaling. A state on the specific field in the control signaling indicates the payload size, and the default value of the RV applies.

[0090] Step 7a02: The terminal fails to receive the packet, and therefore, returns a NACK.

[0091] Step 7a03: The base station sends the control signaling again, and retransmits the packet (as illustrated by dotted line 7a03), where NDI=0 in the control signaling. A state on the specific field indicates the RV1.

[0092] Step 7a04: The terminal fails to receive the packet, and therefore, returns a NACK, which is mistaken as ACK by the base station.

[0093] Step 7a05: The base station sends the control signaling corresponding to a new packet initially and sends the new packet (as illustrated by dotted line 7a05), where the NDI=1 in the control signaling. A state on the specific field indicates the payload size, and the default value of the RV applies.

[0094] As regards the scenario shown in FIG. 7b, in step 7b04, the terminal fails to receive the control signaling and returns a DTX, which is mistaken as ACK by the base station. The remaining steps are the same as the counterpart in FIG. 7a, and are not repeated here any further.

[0095] Scenario 6: In this scenario, the base station receives a DTX returned by the terminal in the process of transmitting the packet initially. As shown in FIG. 8, the DTX may indicate an error of the initially transmitted control signaling, or the terminal that transmits the packet initially returns a NACK which is mistaken as DTX by the base station, or the terminal that transmits the packet initially returns an ACK which is mistaken as DTX by the base station.

[0096] Step 801: The base station sends the control signaling corresponding to the packet initially and sends the packet (as illustrated by dotted line 801), where the NDI=0 in the control signaling. A state on the specific field in the control signaling indicates the payload size. The default value of the RV applies.

[0097] Step 802: The terminal fails to receive the control signaling, and therefore, returns a DTX.

[0098] An alternative of this step may include the steps where, the terminal receives the control signaling successfully but fails to receive the data. The terminal returns a NACK which is mistaken as DTX by the base station, as described in step 802'.

[0099] Another alternative of this step may include, the terminal receives the control signaling and data successfully. The terminal returns an ACK which is mistaken as DTX by the base station, as described in step 802".

[0100] Step 803: The base station sends the control signaling again and retransmits the packet (as illustrated by dotted line 803), where the NDI=0 in the control signaling. A state on the specific field indicates the payload size. The default value of the RV may apply.

[0101] Step 804: The terminal receives the packet successfully, and therefore, returns an ACK message.

[0102] Scenario 7: In this scenario, in the process of retransmitting the packet, the base station receives a DTX returned by the terminal and the maximum retransmission count is not reached. Therefore, the base station sends the control signaling again and retransmits the packet, where the NDI=0 in the control signaling. A state on the specific field in the control signaling indicates the payload size, and the default value of the RV applies; or a state on the field indicates the RV.

[0103] The scenario may be divided into two circumstances, as shown in FIG. 9a and FIG. 9b respectively.

[0104] FIG. 9a illustrates the following steps.

[0105] Step 9a01: The base station sends the control signaling corresponding to the packet initially and sends the packet (as illustrated by dotted line 9a01), where the NDI=0 in the control signaling. A state on the specific field indicates the payload size. The default value of the RV applies.

[0106] Step 9a02: The terminal fails to receive the packet, and therefore, returns a NACK.

[0107] Step 9a03: The base station sends the control signaling again, and retransmits the packet (as illustrated by dotted line 9a03), where NDI=0 in the control signaling. A state on the specific field indicates the RV1.

[0108] Step 9a04: The terminal fails to receive the control signaling, and therefore, returns a DTX.

[0109] An alternative of this step may include that the terminal fails to receive the packet, and therefore, returns a NACK, which is mistaken as DTX by the base station, as described in step 9a04'.

[0110] Another alternative of this step may include that the terminal receives the packet successfully, and therefore, returns an ACK, which is mistaken as DTX by the base station, as described in step 9a04".

[0111] Step 9a05: The terminal obtains the payload size correctly beforehand in the foregoing steps 9a04, 9a04' and 9a04". Therefore, in step 9a05, when the base station sends the control signaling, it is not necessary to send the payload size again, but the RV2 is sent instead. A state on the specific field indicates the RV2, and the packet is retransmitted (as illustrated by dotted line 9a05).

[0112] Step 9a06: The terminal receives the packet correctly, and therefore, returns an ACK.

[0113] FIG. 9b illustrates the following steps.

[0114] Step 9b01: The base station sends the control signaling corresponding to the packet initially and sends the packet (as illustrated by dotted line 9b01), where the NDI=0 in the control signaling. A state on the specific field in the control signaling indicates the payload size. The default value of the RV applies.

[0115] Step 9b02: The terminal fails to receive the control signaling, and therefore, returns a DTX, which is mistaken as NACK by the base station.

[0116] Step 9b03: The base station sends the control signaling again, and retransmits the packet (as illustrated by dotted line 9b03), where NDI=0 in the control signaling. A state on the specific field indicates the RV1.

[0117] Step 9b04: The terminal returns a DTX.

[0118] In this step, the terminal may receive the control signaling successfully or not. In either case, the terminal may not receive the retransmitted packet because the control signaling carries no payload size message even if the control signaling is received successfully, and no payload size message is obtained from the previous control signaling.

[0119] Step 9b05: The base station sends the control signaling again and retransmits the packet (as illustrated by dotted line 9b05), where the NDI=0 in the control signaling. A state on the specific field indicates the payload size. The default value of the RV may apply.

[0120] Step 9b06: The terminal receives the control signaling and packet successfully, and therefore, returns an ACK.

[0121] The scenarios 9a and 9b may reveal that when the base station receives a DTX returned by the terminal, a state on the field in the control signaling to be transmitted next time indicates the payload size or RV.

[0122] The base station may determine whether the field in the control signaling to be transmitted next time indicates the RV rather than the conventional payload size according to whether the count of transmission of the packet reaches a pre-defined value. Generally, if the count of transmission of the packet reaches or exceeds the pre-defined value, it is determined that the terminal obtains the payload size success-

fully in the previous transmission process. Therefore, the base station may let the field carry the RV in the next signaling transmission.

**[0123]** Scenario 8: In this scenario, when the maximum retransmission count is reached in the retransmission process, the base station receives a DTX returned by the terminal, and therefore, transmits a new packet, as shown in FIG. 10:

**[0124]** Step 1001: The base station sends the control signaling corresponding to the packet initially and sends the packet (as illustrated by dotted line 1001), where the NDI=0 in the control signaling. A state on the specific field in the control signaling indicates the payload size. The default value of the RV applies.

**[0125]** Step 1002: The terminal fails to receive the packet, and therefore, returns a NACK.

**[0126]** Step 1003: The base station sends the control signaling again, and retransmits the packet (as illustrated by dotted line 1003), where NDI=0 in the control signaling. A state on the specific field indicates the RV1.

**[0127]** In the subsequent retransmission process, the terminal fails to receive the packet.

**[0128]** Step 1004: The base station sends the control signaling corresponding to the packet at the last attempt, and retransmits the packet (as illustrated by dotted line 1004), where NDI=0 in the control signaling. A state on the specific field indicates the RV\_max.

**[0129]** Step 1005: The terminal fails to receive the control signaling, and therefore, returns a DTX.

**[0130]** An alternative of this step may include that the terminal fails to receive the packet, and therefore, returns a NACK, which is mistaken as DTX by the base station, as described in step 1005'.

**[0131]** Another alternative of this step may include that the terminal receives the packet successfully, and therefore, returns an ACK, which is mistaken as DTX by the base station, as described in step 1005''.

**[0132]** Under any situation, the packet is referred to the upper layer subsequently.

**[0133]** Step 1006: The base station sends the control signaling corresponding to a new packet initially and sends the new packet, where the NDI=1 in the control signaling. A state on the specific field indicates the payload size. The default value of the RV applies.

**[0134]** Eight scenarios of applying the embodiments of the present invention are described above, taking downlink data transmission as an example. In practice, the method under the present invention may be applicable to uplink data transmission as well.

**[0135]** The foregoing embodiments of the present invention reveal that different states of one field in the control signaling may indicate the payload size or RV. At the time of sending the control signaling, the payload size or RV that is sent is indicated on the specific field, thus vacating the field occupied by the information not required to be indicated, and saving physical resources.

**[0136]** An apparatus for sending control signaling consistent with some embodiments is described below. FIG. 11 is a block diagram of the apparatus. The apparatus may include multiple units, including, for example: a control signaling generating unit 111, adapted to generate control signaling, where different states of one field in the control signaling indicate the payload size or RV; and a control signaling sending unit 112, connected with the control signaling generating

unit 111 and adapted to send the control signaling indicative of the payload size or RV on the field.

**[0137]** The control signaling generating unit 111 may further include: a control signaling determining unit 1111, adapted to determine whether the data that needs to be indicated on the field of the sent control signaling is payload size or RV; and a control signaling field filling unit 1112, adapted to fill the field of the control signaling according to the payload size or RV determined by the control signaling determining unit 1111. The control signaling determining unit 1111 determines that the data to be indicated on the field of the control signaling is a payload size if the packet is transmitted initially. The control signaling determining unit 1111 determines that the data to be indicated on the field of the control signaling is an RV if the packet transmission count reaches or exceeds a pre-defined value when DTX is detected; and determines that the data to be indicated on the field of the control signaling is a payload size if the packet transmission count does not reach the pre-defined value in the retransmission process. The control signaling determining unit 1111 determines that the data to be indicated on the field of the control signaling is an RV if data transmission failure is detected.

**[0138]** The apparatus may be integrated in the transmitter of the control signaling, for example, in a base station. In case where the transmitter may be a base station, the receiver may be a terminal.

**[0139]** The process of sending control signaling through the foregoing apparatus may be similar, and is not repeated here any further.

**[0140]** The foregoing embodiments may reveal that different states of one field in the control signaling may indicate the payload size or RV. At the time of sending the control signaling, the payload size or RV sent is indicated on the generated field, thus vacating the field occupied by the information not required to be indicated, and saving physical resources.

**[0141]** Although the invention has been described through some exemplary embodiments, the invention is not limited to such embodiments. It is apparent that those skilled in the art can make various modifications and variations to the invention without departing from the spirit and scope of the invention. The invention is intended to cover the modifications and variations provided that they fall in the scope of protection defined by the following claims or their equivalents.

What is claimed is:

1. A method of signaling comprising:

receiving, by a terminal, downlink control signaling from a base station (BS); and

sending, by the terminal, an uplink packet to the BS, the uplink packet being sent according to the received downlink control signaling,

wherein the downlink control signaling comprises a field, wherein the field includes N bits,

wherein the field itself is dynamically indicative of a payload size or a Redundancy Version (RV),

wherein the field itself is indicative of the payload size if the uplink packet is an initial transmission, and

wherein the field itself is indicative of the RV if the uplink packet is a retransmission.

2. The method of claim 1, further comprising:  
determining, by the terminal, that the RV is a default value if the received downlink control signaling is indicative of the payload size on the field.
3. The method of claim 1, wherein receiving the downlink control signaling comprises:  
sending, by the terminal, a detecting Discontinuous Transmission signal to the BS; and  
receiving, by the terminal, the downlink control signaling indicative of the payload size or RV in the field.
4. The method of claim 3, wherein receiving the downlink control signaling comprises:  
receiving, by the terminal, the downlink control signaling indicating the RV in the field of the downlink control signaling to be received a next time if a packet transmission count reaches or exceeds a pre-defined value; and  
receiving, by the terminal, the downlink control signaling indicating the payload size in the field of the downlink control signaling to be received the next time if the packet transmission count does not reach the pre-defined value.
5. An apparatus for signaling comprising:  
a downlink control signaling receiver, configured to receive downlink control signaling from a base station (BS), wherein the downlink control signaling comprises a field, wherein the field includes N bits, wherein the field itself is dynamically indicative of one of a payload size or a Redundancy Version (RV) such that the field itself is indicative of the payload size if an uplink packet being sent to a base station is an initial transmission, and the field itself is indicative of the RV if the uplink packet being sent to the base station is a retransmission; and  
a transmitter, configured to send the uplink packet to the BS, the uplink packet sent according to the received downlink control signaling.
6. The apparatus of claim 5, further comprising a processor, configured to determine that the RV is a default value if the received downlink control signaling is indicative of the payload size on the field.
7. The apparatus of claim 6, wherein the apparatus is integrated into a terminal.

\* \* \* \* \*